

Name: _____ ()

Class: 19 / _____



ANDERSON SERANGOON JUNIOR COLLEGE

2019 JC2 Preliminary Examination

PHYSICS Higher 2

9749/01

Paper 1 Multiple Choice

Thursday 19 September 2019

1 hour

Additional Materials: Multiple Choice Answer Sheet

READ THESE INSTRUCTIONS FIRST

Write in soft pencil.

Write your name and class on the Multiple Choice Answer Sheet.

Shade and write your NRIC/FIN.

There are **thirty** questions on this paper. Answer **all** questions. For each question there are four possible answers **A, B, C** and **D**.

Choose the **one** you consider correct and record your choice in **soft pencil** on the Multiple Choice Answer Sheet.

Each correct answer will score one mark. A mark will not be deducted for a wrong answer.

Any rough working should be done in this question paper.

The use of an approved scientific calculator is expected, where appropriate.

This document consists of 17 printed pages and 3 blank pages.

9749/01/ASRJC/2019PRELIM

[Turn Over

Data

speed of light in free space	$c = 3.00 \times 10^8 \text{ m s}^{-1}$
permeability of free space	$\mu_0 = 4\pi \times 10^{-7} \text{ H m}^{-1}$
permittivity of free space	$\epsilon_0 = 8.85 \times 10^{-12} \text{ F m}^{-1}$ $(1/(36\pi)) \times 10^{-9} \text{ F m}^{-1}$
elementary charge	$e = 1.60 \times 10^{-19} \text{ C}$
the Planck constant	$h = 6.63 \times 10^{-34} \text{ J s}$
unified atomic mass constant	$u = 1.66 \times 10^{-27} \text{ kg}$
rest mass of electron	$m_e = 9.11 \times 10^{-31} \text{ kg}$
rest mass of proton	$m_p = 1.67 \times 10^{-27} \text{ kg}$
molar gas constant	$R = 8.31 \text{ J K}^{-1} \text{ mol}^{-1}$
the Avogadro constant	$N_A = 6.02 \times 10^{23} \text{ mol}^{-1}$
the Boltzmann constant	$k = 1.38 \times 10^{-23} \text{ J K}^{-1}$
gravitational constant	$G = 6.67 \times 10^{-11} \text{ N m}^2 \text{ kg}^{-2}$
acceleration of free fall	$g = 9.81 \text{ m s}^{-2}$

Formulae

uniformly accelerated motion

$$s = ut + \frac{1}{2}at^2$$

$$v^2 = u^2 + 2as$$

work done on/by a gas

$$W = p\Delta V$$

hydrostatic pressure

$$p = \rho gh$$

gravitational potential

$$\phi = -\frac{Gm}{r}$$

temperature

$$T/K = T/^\circ\text{C} + 273.15$$

pressure of an ideal gas

$$p = \frac{1}{3} \frac{Nm}{V} \langle c^2 \rangle$$

mean translational kinetic energy of an ideal gas molecule

$$E = \frac{3}{2}kT$$

displacement of particle in s.h.m.

$$x = x_0 \sin \omega t$$

velocity of particle in s.h.m.

$$v = v_0 \cos \omega t$$

$$= \pm \omega \sqrt{x_0^2 - x^2}$$

electric current

$$I = Anvq$$

resistors in series

$$R = R_1 + R_2 + \dots$$

resistors in parallel

$$1/R = 1/R_1 + 1/R_2 + \dots$$

electric potential

$$V = \frac{Q}{4\pi\epsilon_0 r}$$

alternating current/voltage

$$x = x_0 \sin \omega t$$

magnetic flux density due to a long straight wire

$$B = \frac{\mu_0 I}{2\pi d}$$

magnetic flux density due to a flat circular coil

$$B = \frac{\mu_0 NI}{2r}$$

magnetic flux density due to a long solenoid

$$B = \mu_0 nI$$

radioactive decay

$$x = x_0 \exp(-\lambda t)$$

decay constant

$$\lambda = \frac{\ln 2}{t_{\frac{1}{2}}}$$

- 1 A double-slit interference experiment is used to determine the wavelength of light from a monochromatic source.

The following measurements are used.

$$\text{slit separation } a = 0.50 \pm 0.02 \text{ mm}$$

$$\text{fringe separation } x = 1.7 \pm 0.1 \text{ mm}$$

$$\text{distance between slits and screen } D = 2.000 \pm 0.002 \text{ m}$$

What is the percentage uncertainty in the calculated wavelength?

- A 0.1% B 1% C 6% D 10%
- 2 In order that a train can stop safely, it will always pass a signal showing a yellow light before it reaches a signal showing a red light. Drivers apply the brake at the yellow light and this results in a uniform deceleration to stop exactly at the red light.

The distance between the red and yellow lights is x .

What must be the minimum distance between the lights if the train speed is increased by 20%, without changing the deceleration of the train?

- A 1.20x B 1.25x C 1.44x D 1.56x
- 3 A ball is thrown horizontally in still air from the top of a tall building.

What happens to the horizontal and to the vertical components of the ball's velocity after a long time?

	horizontal component of velocity	vertical component of velocity
A	decreases to zero	increases at a constant rate
B	decreases to zero	increases to a constant value
C	remains constant	increases at a constant rate
D	remains constant	increases to a constant value

- 4 A box is shown resting on the ground. Newton's third law implies that four forces of equal magnitude are involved. These forces are labelled P, Q, R and S.

Forces P and Q act on the box. Forces R and S act on the Earth.

For clarity, the forces are shown slightly separated.

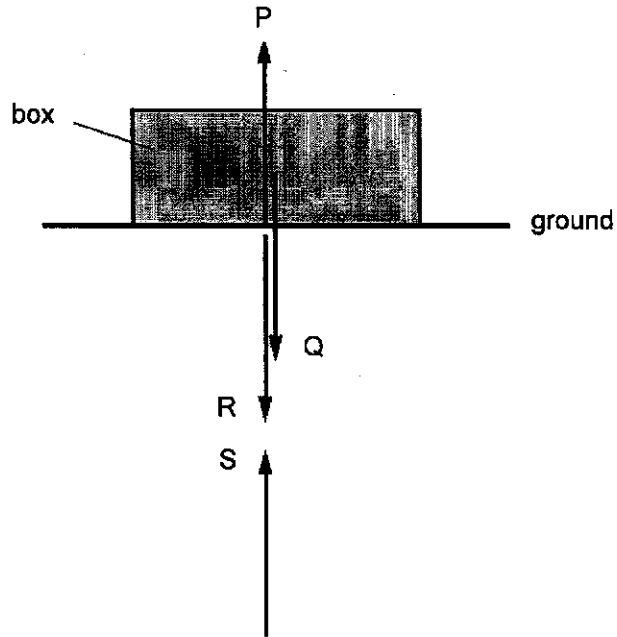

Which statement about the forces is correct?

- A P is the equal and opposite force to Q and both are forces of contact.
- B Q is the equal and opposite force to P and both are gravitational forces.
- C R is the equal and opposite force to S and both are forces of contact.
- D S is the equal and opposite force to Q and both are gravitational forces.

- 5 A small ball P moves with speed v towards another identical ball Q along a line joining the centres of the two balls. Ball Q is at rest. They collide elastically.



Which one of the following situations is the outcome of the collision between the balls?

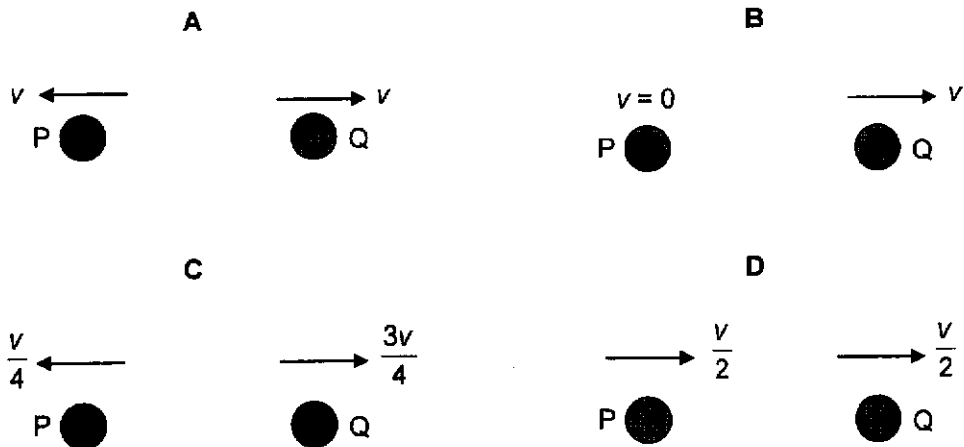

- 6 A ball rests against two frictionless walls, X and Y, as shown in the figure below.

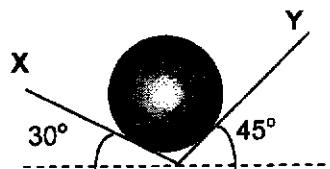

What is the ratio of reaction forces of wall X to that of wall Y?

- A 0.71 B 0.82 C 1.0 D 1.4

- 7 A ball bearing is thrown downwards at high speed in a viscous liquid. Which of the following graphs would represent the variation of the upthrust and viscous force acting on the ball bearing with time?

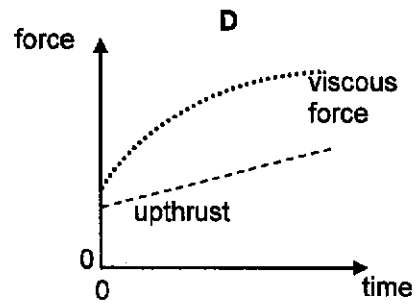
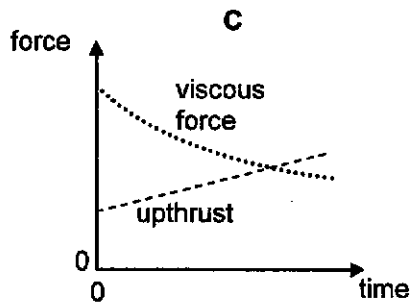
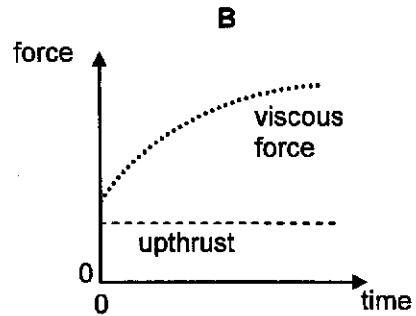
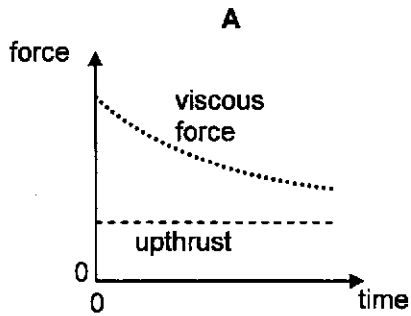

- 8 A mass is attached to the end of a spring which obeys Hooke's law. When a load of 3.0 N is placed on the spring, the spring is extended by 0.030 m. What additional elastic potential energy will be stored in the spring if it is then extended a further 0.010 m?

A 0.0050 J B 0.030 J C 0.035 J D 0.080 J

- 9 The diagram shows two bodies X and Y connected by a light cord passing over a light, free-running pulley. X starts from rest and moves on a slope inclined at 30° to the horizontal. X has a mass of 4.0 kg, and Y has a mass of 5.0 kg. Friction between X and the slope is 5.0 N.

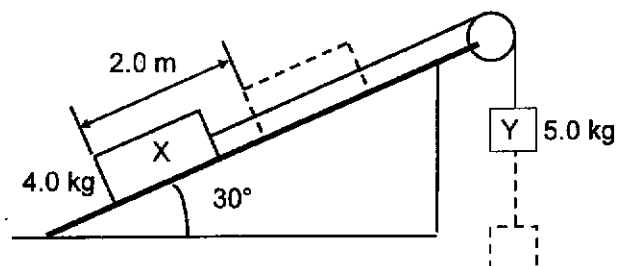

Which of the following is the total kinetic energy of the system when X has travelled 2.0 m along the plane?

- A 9.6 J B 30 J C 49 J D 69 J
- 10 A passenger is sitting in a railway carriage facing in the direction in which the train is travelling. A pendulum hangs down in front of him from the carriage roof. The train travels along a circular arc bending to the right.

Which one of the follow diagrams shows the position of the pendulum as seen by the passenger and the directions of the forces acting on it?

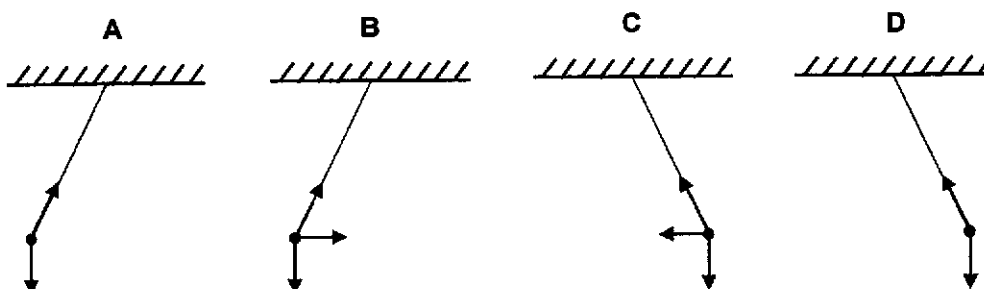

- 11 Two satellites, A and B, orbiting around Earth have the same kinetic energy. Satellite A has a larger mass than satellite B. Which of the following statements is correct?
- A Satellite A has the same total energy as satellite B.
- B Satellite A has a smaller gravitational potential energy than satellite B.
- C Satellite A has a larger gravitational potential energy than satellite B.
- D Satellite A has a larger angular velocity than satellite B.

- 12 An ideal gas is contained in a cylinder with a movable piston. At pressure p , volume V and temperature T , it has N_v molecules per unit volume. If the pressure of the gas is changed to $0.50p$, and the temperature to $2.0T$, the number of molecules per unit volume becomes
- A $0.25 N_v$ B $0.50 N_v$ C $1.0 N_v$ D $4.0 N_v$
- 13 Which statement about internal energy is correct?
- A The internal energy of a system can be increased without transfer of heat.
- B The internal energy of a system is the sum of the kinetic energies of the molecules.
- C When the internal energy of a system is increased, its temperature always rises.
- D When two systems have the same internal energy, they must be at the same temperature.
- 14 An ideal gas has thermodynamic temperature T , and its molecules has root-mean-square speed c_{rms} . If the gas is heated to temperature $2T$, what is the new root-mean-square speed of the molecules?
- A $\sqrt{2}c_{rms}$ B $2c_{rms}$ C $2\sqrt{2}c_{rms}$ D $4c_{rms}$
- 15 Diagram 1 shows the variation with displacement x of velocity v of a simple harmonic oscillator. Diagram 2 shows the variation with time t of the velocity v of the oscillator.

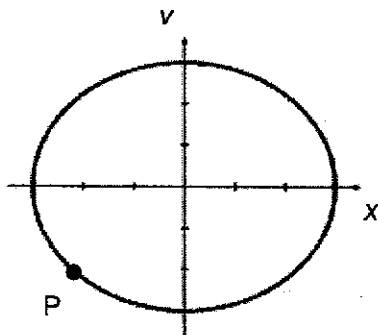

diagram 1

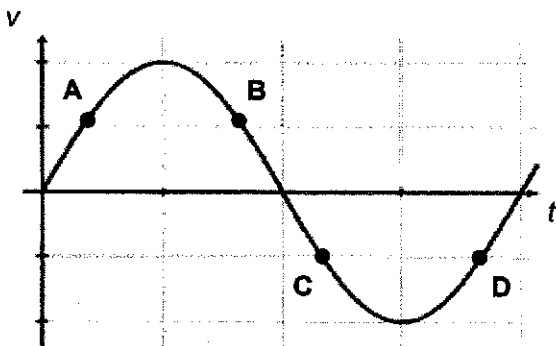

diagram 2

Which of the points on diagram 2 corresponds to the state of motion represented by point P on diagram 1?

16 Which statement about a light wave and a sound wave is correct?

- A Both can be polarised.
- B Both can travel through free space.
- C Both have a frequency inversely proportional to their wavelength.
- D Both have an intensity proportional to their amplitude.

17 A light wave of amplitude A is incident normally on a surface of area S . The power per unit area reaching the surface is P .

The amplitude of the light wave is increased to $2A$. The light is then focused on to a smaller area $\frac{1}{3}S$.

What is the power per unit area on this smaller area?

- A $6P$
- B $12P$
- C $18P$
- D $36P$

- 18 A receiver aerial is placed on a laboratory bench between a transmitter emitting microwaves at a single fixed frequency and a metal sheet.

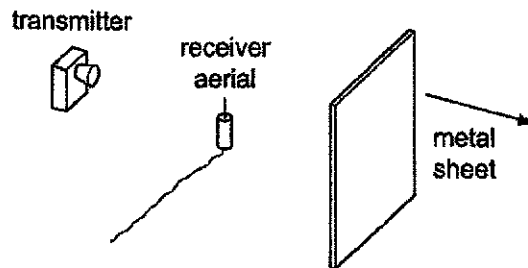

The metal sheet is moved away from the aerial. The detected voltage at the receiver aerial varies with the distance moved by the sheet as shown.

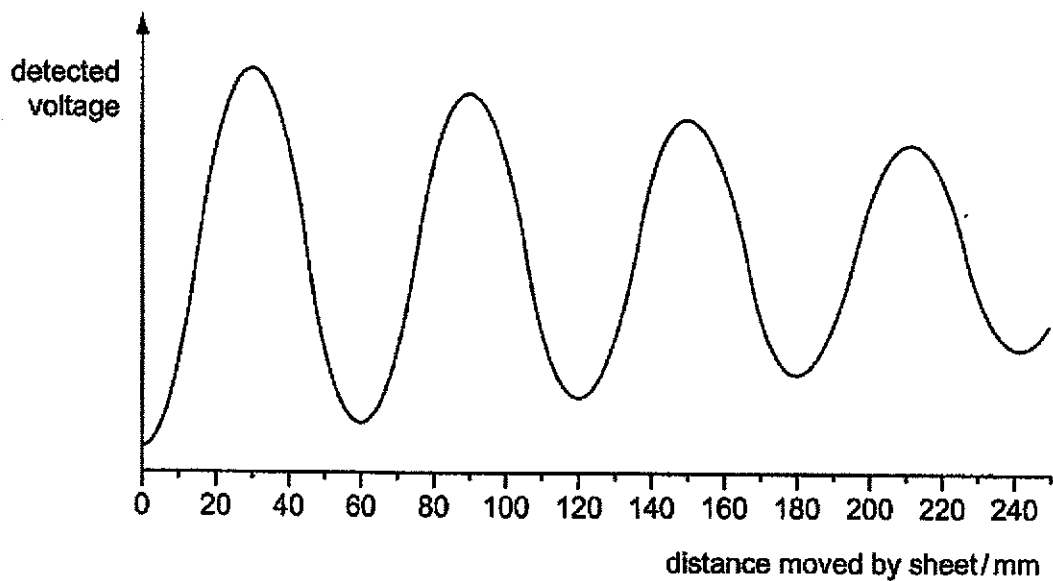

What is the wavelength of the microwaves?

- A 180 mm B 120 mm C 60 mm D 30 mm

- 19 A combination of eight electrons (denoted by \ominus) and protons (denoted by \bullet) are fixed in place and evenly spread along the circumference of circle as shown.

Which of the combinations has the smallest magnitude of resultant electric field strength at the centre of the circle?

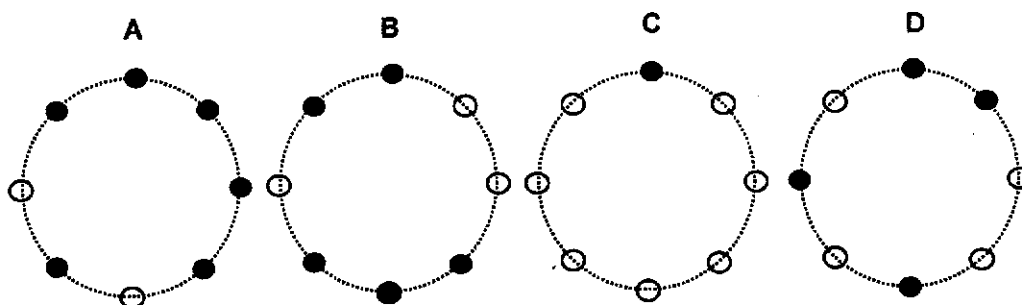

- 20 An electron is projected horizontally with a speed of $3.1 \times 10^7 \text{ m s}^{-1}$. It passes in between the two charged horizontal plates. The uniform electric field between the plates is 20000 N C^{-1} . As the electron passes through the plates, it is deflected. The time taken for the electron to travel the length of the plate is $4.0 \times 10^{-9} \text{ s}$.

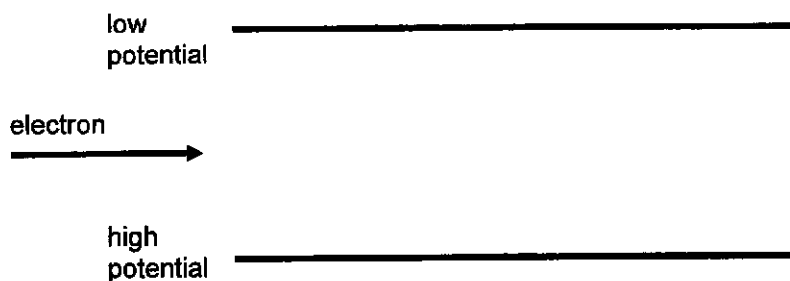

What is the vertical distance travelled by the electron after it has travelled the length of the plate?

- A $1.76 \times 10^{-17} \text{ m}$ B $7.85 \times 10^{-17} \text{ m}$ C 0.0281 m D 0.152 m
- 21 The potential difference between point X and point Y in an electric circuit is 18 V . The current passing through is 1.5 A and the time taken for charge carriers to move from X to Y is 0.2 s .

What is the change in the energy of the charge carriers as they pass between X and Y?

- A 0.017 J B 5.4 J C 60 J D 135 J

- 22 A battery of e.m.f. 6.0 V and negligible internal resistance is connected to three resistors, each of resistance R , and a variable resistor T , as shown.

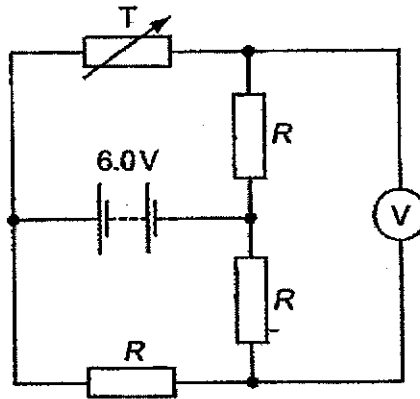

The resistance of T changes from R to $2R$.

What is the change in the reading of the high resistance voltmeter?

- A zero B 1V C 2V D 3V

- 23 A current I is carried by a rectangular coil of n turns and side L suspended vertically as shown in a uniform horizontal magnetic field of flux density B .

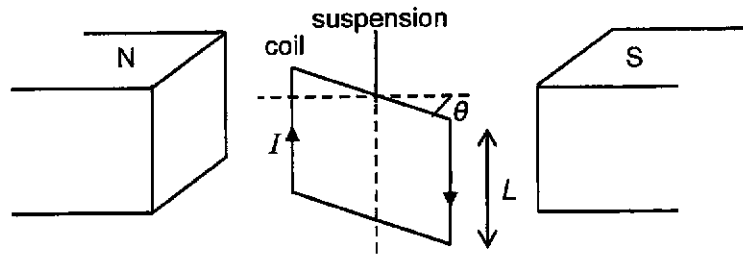

Which of the following diagrams, viewed from the top, correctly shows the magnitude and direction of the forces acting on the vertical sides of the coil?

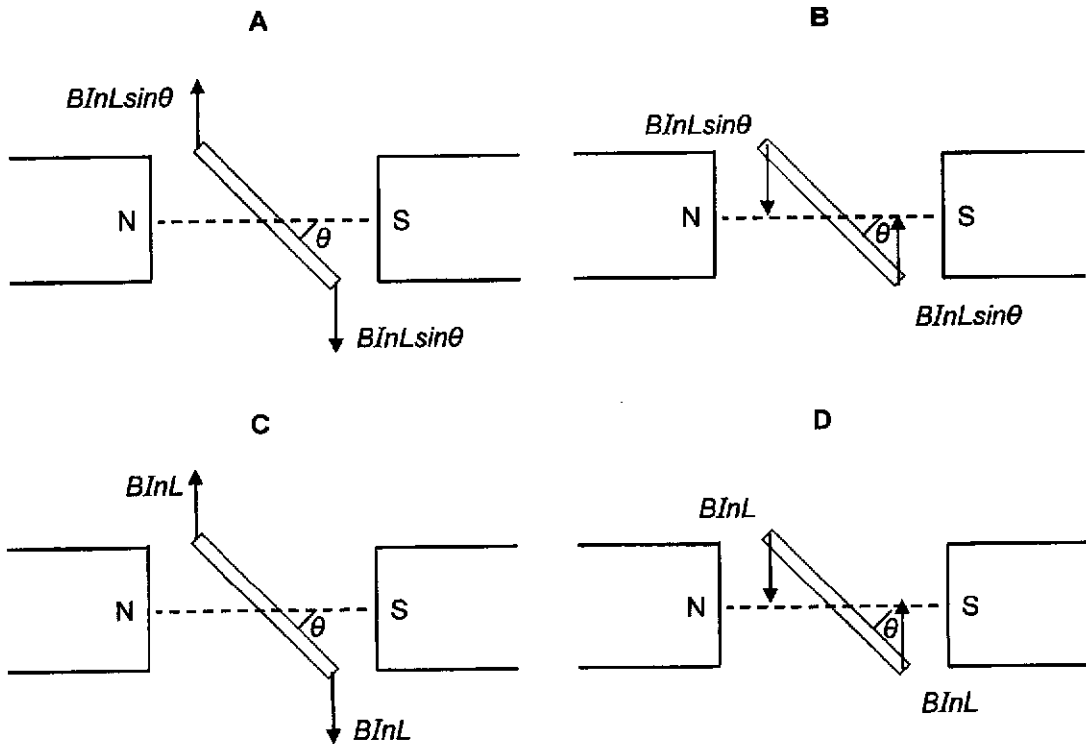

- 24 Diagram 1 shows an aluminium rod, moving at right angles to a uniform magnetic field. Diagram 2 shows the variation with time t of the distance s from O.

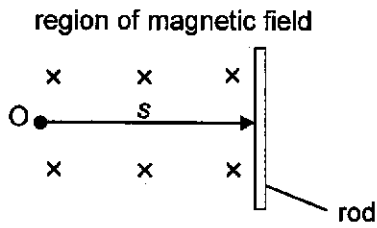

diagram 1

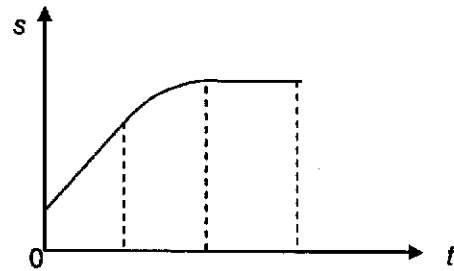
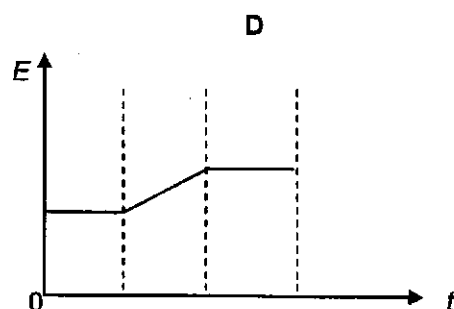
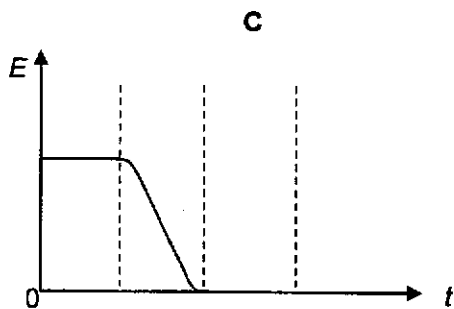
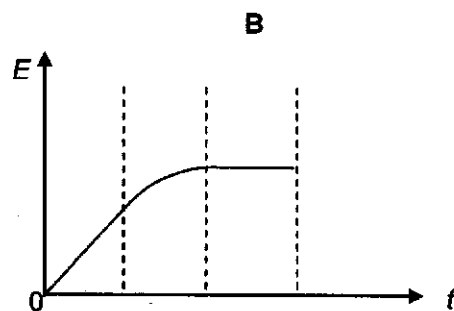
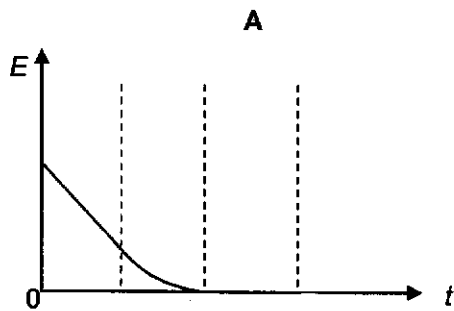

diagram 2

Which graph best shows the variation of t of the e.m.f. E induced in the rod?



- 25 An alternating current of peak value 2 A and a steady direct current I flowing through identical resistors dissipate heat at equal rates.

What is the value of current I ?

A $\frac{1}{2\sqrt{2}}$ A

B $\sqrt{2}$ A

C 2 A

D $2\sqrt{2}$ A

- 26 The primary coil of a transformer is connected to an alternating voltage supply. The secondary coil is connected across a variable resistor.

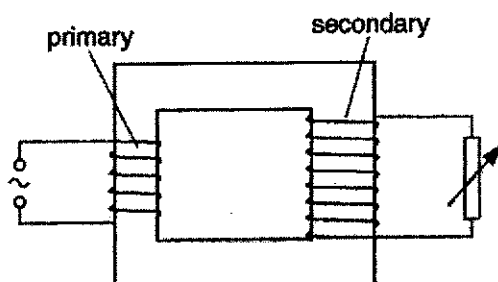

Which change will cause a decrease in the p.d. across the secondary coil?

- A Increasing the number of turns of the primary coil
 B Increasing the cross-sectional area of the secondary coil
 C Increasing the resistance of the variable resistor
 D Decreasing the resistance of the variable resistor
- 27 In an X-ray tube, electrons, each with a charge q , are accelerated through a potential difference V and are then made to strike a metal target. If h is the Planck constant and c is the speed of light, what is the expression for the minimum wavelength of the emitted radiation?
- A $\frac{hq}{cV}$ B $\frac{qV}{hc}$ C $\frac{qV}{h}$ D $\frac{hc}{qV}$
- 28 An electron is measured to have a speed of $2.05 \times 10^8 \text{ m s}^{-1}$ in the x-direction. The precision in measuring its speed is 0.50%.
- What is the minimum uncertainty of its position of the electron along the x-direction?
- A 0 B $3.37 \times 10^{-20} \text{ m}$ C $1.97 \times 10^{-14} \text{ m}$ D $7.10 \times 10^{-8} \text{ m}$

- 29 Which of the following statements concerning nuclear properties is true?
- A The greater the binding energy of a nucleus, the more stable it is.
 - B If the total rest mass of the products of a reaction is greater than the total rest mass of the reactants, this reaction is impossible.
 - C When a stationary nucleus decays by emitting a γ -photon, the nucleus will move off in an opposite direction to the photon.
 - D The half-life of a radioactive substance can be changed by allowing the substance to react chemically to produce a new radioactive compound.
- 30 Radiation from a radioactive source enters an evacuated region in which there is a uniform magnetic field perpendicular to the plane of the diagram. This region is divided into two by a sheet of aluminum about 1 mm thick. The curved, horizontal path followed by the radiation is shown in the diagram below.

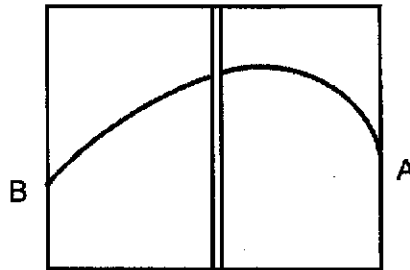

Which of the following correctly describes the type of radiation and its point of entry?

	type of radiation	point of entry
A	alpha	A
B	alpha	B
C	beta	A
D	beta	B

BLANK PAGE

BLANK PAGE

BLANK PAGE

Name: _____ ()

Class: 19 / _____



ANDERSON SERANGOON JUNIOR COLLEGE

2019 JC2 Preliminary Examination

PHYSICS Higher 2

9749/02

Paper 2 Structured Questions

Tuesday 17 September 2019

2 hours

Candidates answer on the Question Paper.
No Additional Materials are required.

READ THESE INSTRUCTIONS FIRST

Write your name, class index number and class in the spaces provided above.
Write in dark blue or black pen on both sides of the paper.
You may use an HB pencil for any diagrams, graphs or rough working.

The use of an approved scientific calculator is expected, where appropriate.
Answer all questions.

At the end of the examination, fasten all your work
securely together.
The number of marks is given in brackets [] at the end of
each question or part question.

For Examiner's Use	
Paper 2 (80 marks)	
1	
2	
3	
4	
5	
6	
7	
Significant Figure	
Total	

This document consists of 23 printed pages and 1 blank page.

9749/02/ASRJC/2019Prelim

[Turn over

Data

speed of light in free space	$c = 3.00 \times 10^8 \text{ m s}^{-1}$
permeability of free space	$\mu_0 = 4\pi \times 10^{-7} \text{ H m}^{-1}$
permittivity of free space	$\epsilon_0 = 8.85 \times 10^{-12} \text{ F m}^{-1}$ $(1/(36\pi)) \times 10^{-9} \text{ F m}^{-1}$
elementary charge	$e = 1.60 \times 10^{-19} \text{ C}$
the Planck constant	$h = 6.63 \times 10^{-34} \text{ J s}$
unified atomic mass constant	$u = 1.66 \times 10^{-27} \text{ kg}$
rest mass of electron	$m_e = 9.11 \times 10^{-31} \text{ kg}$
rest mass of proton	$m_p = 1.67 \times 10^{-27} \text{ kg}$
molar gas constant	$R = 8.31 \text{ J K}^{-1} \text{ mol}^{-1}$
the Avogadro constant	$N_A = 6.02 \times 10^{23} \text{ mol}^{-1}$
the Boltzmann constant	$k = 1.38 \times 10^{-23} \text{ J K}^{-1}$
gravitational constant	$G = 6.67 \times 10^{-11} \text{ N m}^2 \text{ kg}^{-2}$
acceleration of free fall	$g = 9.81 \text{ m s}^{-2}$

Formulae

uniformly accelerated motion

$$s = ut + \frac{1}{2}at^2$$

$$v^2 = u^2 + 2as$$

work done on/by a gas

$$W = p\Delta V$$

hydrostatic pressure

$$p = \rho gh$$

gravitational potential

$$\phi = -\frac{Gm}{r}$$

temperature

$$T/K = T/^\circ\text{C} + 273.15$$

pressure of an ideal gas

$$p = \frac{1}{3} \frac{Nm}{V} \langle c^2 \rangle$$

mean translational kinetic energy of an ideal gas molecule

$$E = \frac{3}{2}kT$$

displacement of particle in s.h.m.

$$x = x_0 \sin \omega t$$

velocity of particle in s.h.m.

$$v = v_0 \cos \omega t$$

$$= \pm \omega \sqrt{x_0^2 - x^2}$$

electric current

$$I = Anvq$$

resistors in series

$$R = R_1 + R_2 + \dots$$

resistors in parallel

$$1/R = 1/R_1 + 1/R_2 + \dots$$

electric potential

$$V = \frac{Q}{4\pi\epsilon_0 r}$$

alternating current/voltage

$$x = x_0 \sin \omega t$$

magnetic flux density due to a long straight wire

$$B = \frac{\mu_0 I}{2\pi d}$$

magnetic flux density due to a flat circular coil

$$B = \frac{\mu_0 NI}{2r}$$

magnetic flux density due to a long solenoid

$$B = \mu_0 nI$$

radioactive decay

$$x = x_0 \exp(-\lambda t)$$

decay constant

$$\lambda = \frac{\ln 2}{t_{\frac{1}{2}}}$$

Answer all the questions in the spaces provided.

- 1 A hollow tube contains some sand. When placed in a liquid, the tube floats upright as shown in Fig. 1.1.

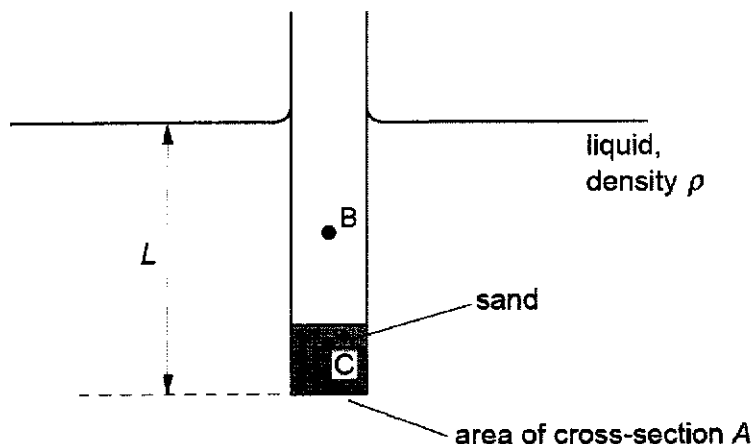

Fig. 1.1

The centre of mass of the tube and the sand is at C.

The centre of buoyancy of the tube, which is the point at which upthrust on the tube may be considered to act, is at B.

- (a) On Fig. 1.1, draw labelled arrows to represent the forces acting on the system of the tube and the sand. [1]
- (b) When placed in water of density 0.99 g cm^{-3} , the length L is 12.1 cm . The tube is then transferred to a liquid of density 1.11 g cm^{-3} . Calculate the change in the submerged length.

change in length =cm [3]

- (c) (i) Explain why, when the tube is tilted at a small angle, it returns to the upright position.

.....
 [1]

- (ii) The tube is now displaced vertically and then released. It undergoes vertical oscillations.

Describe the restoring force that gives rise to the oscillations.

.....
.....
.....
..... [2]

[Total: 7]

- (b) The rocket motor is switched off at point A. During the journey from A to B, the rocket has a constant mass of 4.7×10^4 kg and its kinetic energy changes from 1.17 TJ to 0.35 TJ.

For the planet, the product GM is 4.0×10^{14} $\text{Nm}^2 \text{kg}^{-1}$. It may be assumed that resistive forces to the motion of the rocket are negligible.

Determine the distance from A to B.

distance =m [4]

- (c) The rocket eventually reaches a distance far away from the planet.

Suggest one similarity and one difference between the gravitational fields at the surface of the planet and at the surface of the rocket.

similarity:

.....

difference:

..... [2]

[Total: 9]

- 3 A ball is held between two fixed points A and B by means of two stretched springs, as shown in Fig. 3.1.

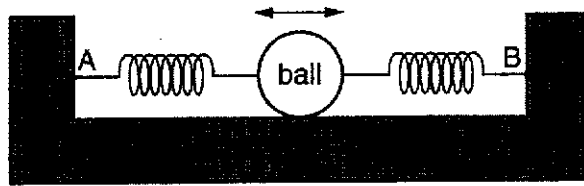

Fig 3.1

The ball is free to oscillate along the straight line AB. The springs remain stretched and the motion of the ball is simple harmonic.

The variation with time t of the displacement x of the ball from its equilibrium position is shown in Fig. 3.2.

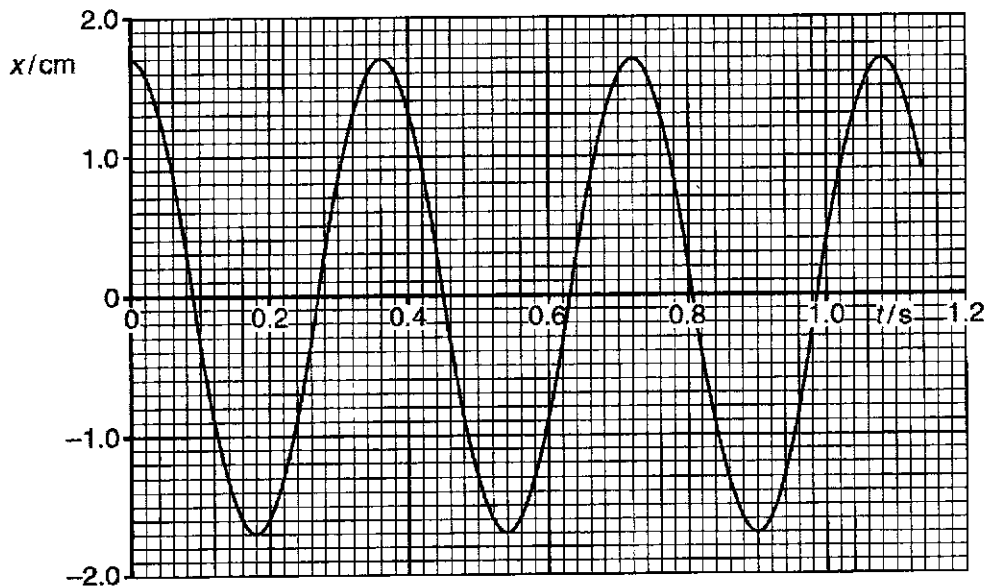

Fig 3.2

- (a) Calculate the maximum acceleration of the ball.

maximum acceleration = m s^{-2} [3]

- (b) Calculate the displacement of the ball at which its kinetic energy is equal to half of the total energy of oscillation.

displacement =cm [3]

- (c) The spring-mass system in Fig 3.1 is placed on a rough vibrating surface. Fig. 3.3 shows how the amplitude of the ball varies with the frequency of the vibrating surface.

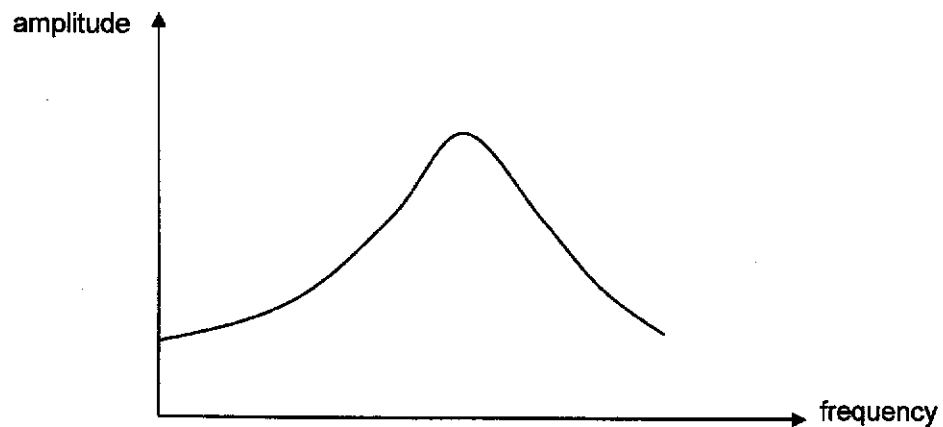

Fig. 3.3

The spring-mass system is then placed on a smoother vibrating surface.

On Fig. 3.3, sketch to show how the amplitude of the ball varies with the frequency of the vibrating surface.

[2]

[Total: 8]

- 4 (a) A ripple tank is used to show the diffraction and interference of waves. On Fig. 4.1, plane wavefronts are shown approaching an object.

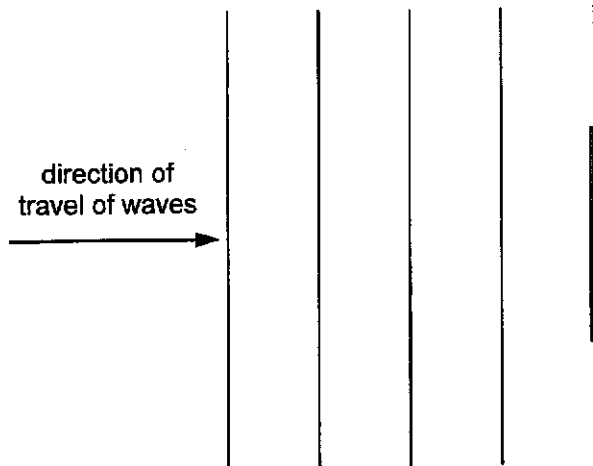

Fig. 4.1

- (i) On Fig. 4.1, draw four wavefronts to show the waves after they have passed through the object. [2]
- (ii) The object is now made shorter.

Describe the change in appearance of the diffracted wavefronts.

.....

..... [1]

(b) A laser is placed in front of a slit as shown in Fig. 4.2.

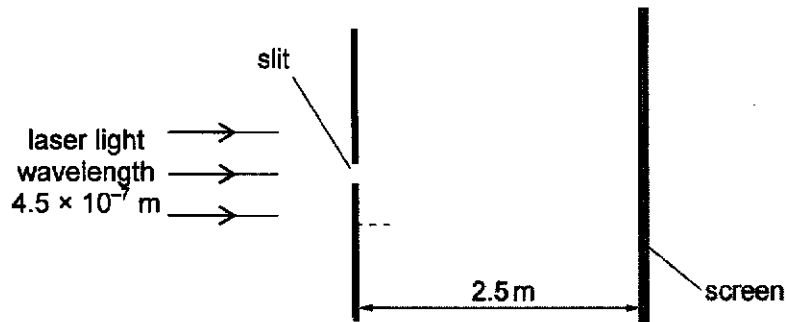

Fig. 4.2 (not drawn to scale)

The laser emits light of wavelength $4.5 \times 10^{-7} \text{ m}$. The distance from the slit to the screen is 2.5 m . The width of the slit is 0.50 mm .

An interference pattern is observed on the screen.

The width of the central fringe as observed on the screen is y .

(i) Show that y is 4.5 mm .

[2]

(ii) The single slit is replaced with a double slit as shown in Fig. 4.3.

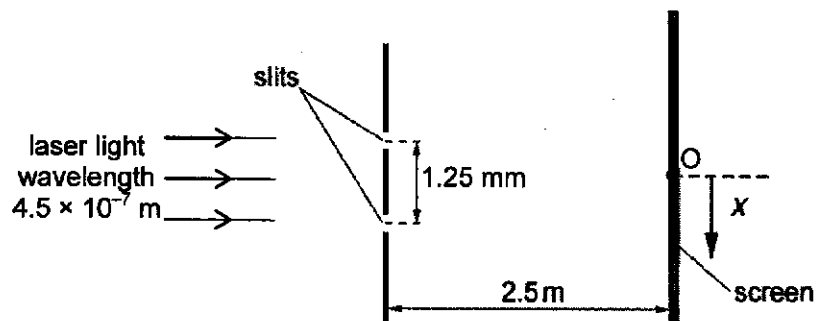

Fig. 4.3 (not drawn to scale)

The separation of the slits is 1.25 mm . The width of each slit is 0.50 mm .

The centre of the interference pattern formed on the screen is at O.

1. Explain why an interference pattern is formed on the screen.

.....

 [3]

2. Show that there are five bright fringes in the region $-\frac{y}{2} \leq x \leq \frac{y}{2}$, where x is the distance measured downwards along the screen from point O.

[2]

3. On Fig. 4.4, sketch the variation with distance x from point O of the intensity I for the image observed on the screen.

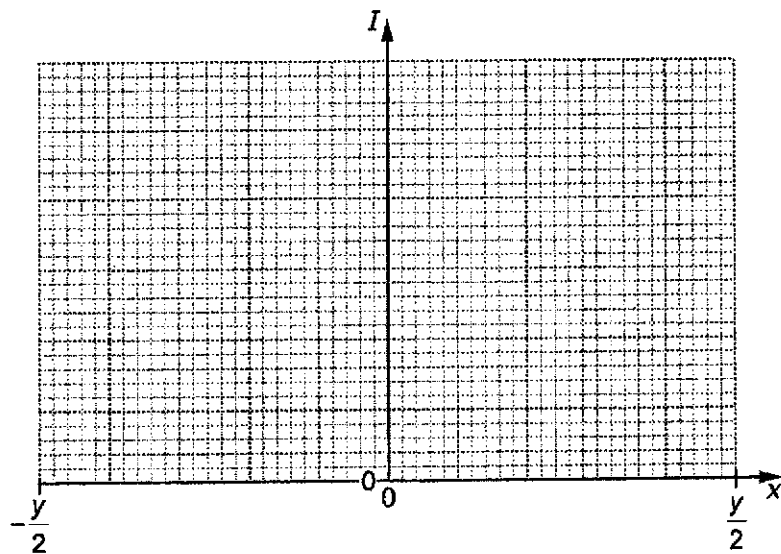

Fig. 4.4

[3]

[Total: 13]

- (b) The solenoid from part (a) has a coil C of wire wound tightly about its centre, as shown in Fig. 5.2.

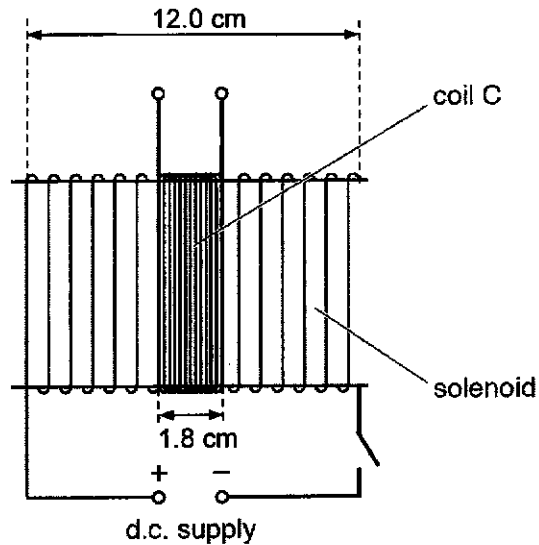

Fig. 5.2 (not drawn to scale)

The solenoid has length 12.0 cm and circumference 8.8 cm, and consists of 360 turns. The coil C has length 1.8 cm and consists of 96 turns.

- (i) Define *magnetic flux*.

.....

 [1]

- (ii) When the switch is closed, the current in the solenoid is 2.5 A.

Show that the magnetic flux in coil C is 5.8×10^{-6} Wb.

[3]

- (iii) Calculate the average electromotive force (e.m.f.) induced in coil C when the current in (b)(ii) is reversed in the solenoid in a time of 2.4 ms.

e.m.f =V [2]

- (iv) The d.c. supply in Fig. 5.1 is now replaced with a sinusoidal alternating supply.

Describe qualitatively the e.m.f. that is now induced in coil C.

.....
.....
..... [2]

[Total: 11]

6 Experiments are conducted to investigate the photoelectric effect.

(a) It is found that, on exposure of a metal surface to light, either electrons are emitted immediately or they are not emitted at all.

Suggest why this observation does not support a wave theory of light.

.....

 [2]

(b) Data for the wavelength λ of the radiation incident on the metal surface and the maximum kinetic energy E_K of the emitted electrons are shown in Fig. 6.1.

λ nm	$E_K / 10^{-19} \text{ J}$
650	–
240	4.44

Fig. 6.1

(i) Without any calculation, suggest why no value is given for E_K for radiation of wavelength 650 nm.

.....
 [1]

(ii) Use data from Fig. 6.1 to determine the work function energy of the metal.

work function energy = J [2]

- (c) Radiation of wavelength 240 nm gives rise to a maximum photoelectric current I . The intensity of the incident radiation is maintained constant and the wavelength is now reduced.

State and explain the effect of this change on

- (i) the maximum kinetic energy of the photoelectrons,

.....
.....
..... [1]

- (ii) the maximum photoelectric current I .

.....
.....
..... [1]

- (d) Light in a beam has a continuous spectrum that lies within the visible region. The photons of the light beam have energies ranging from 1.60 eV to 2.60 eV.

The beam passes through some hydrogen gas. It then passes through a diffraction grating and an absorption spectrum is observed.

- (i) All of the light absorbed by the hydrogen is re-emitted. Explain why dark lines are still observed in the absorption spectrum.

.....
..... [1]

- (ii) Some of the energy levels of an electron in a hydrogen atom are illustrated in Fig. 6.2.

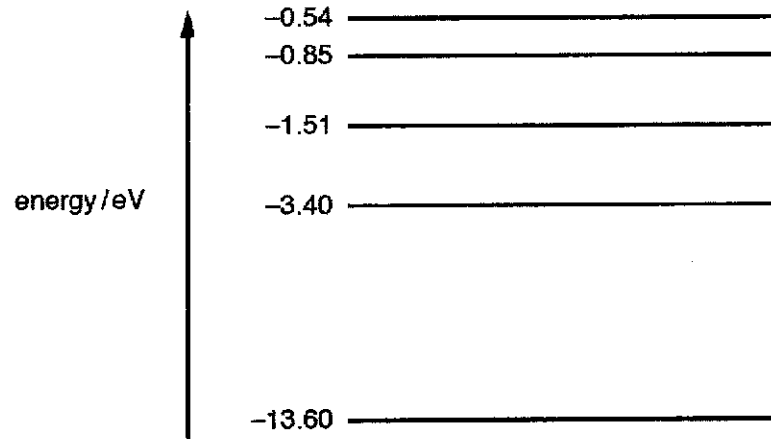

Fig. 6.2 (not to scale)

The dark lines in the absorption spectrum are the result of electron transitions between energy levels.

On Fig. 6.2, draw arrows to show the initial electron transitions between energy levels that could give rise to dark lines in the absorption spectrum. [2]

- (iii) Calculate the shortest wavelength of the light in the beam.

wavelength =m [2]

[Total: 12]

- 7 When some substances are in the solid state, they exist as positively-charged and negatively-charged ions arranged in a cubic lattice, as illustrated in Fig. 7.1.

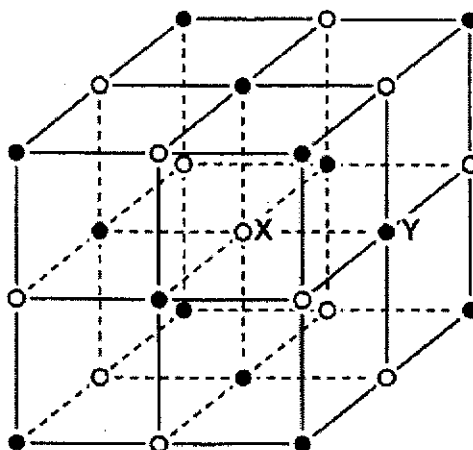

Fig. 7.1

A starting point for the understanding of lattice energies is to consider the potential energy E_p between two ions X and Y.

Fig. 7.2 shows the variation with the distance r between X and Y of E_p .

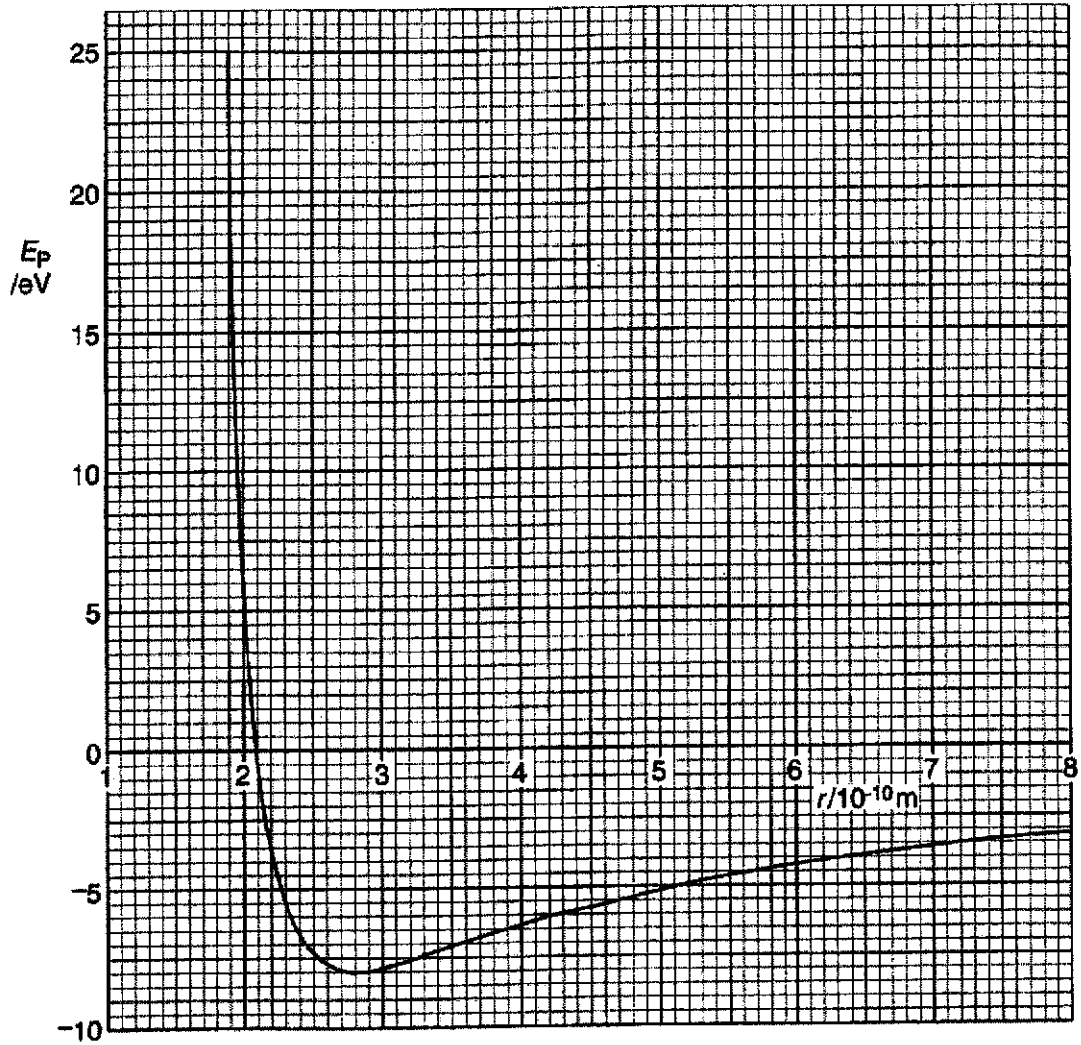

Fig. 7.2

- (a) (i) The gradient G of the graph varies with the distance r . Show that, starting from the definition of *work done*, for any value of r the magnitude of the force F between X and Y is given by the expression

$$F = G.$$

.....

 [2]

- (ii) Suggest how Fig. 7.2 indicates that, for some values of r , the force between X and Y is attractive and, for other distances, the force is repulsive.

.....

 [2]

- (iii) Use Fig. 7.2 and the expression in (i) to determine the magnitude of the force, in newton, for values of the distance r equal to

1. 2.8×10^{-10} m,

force =N [1]

2. 5.0×10^{-10} m.

force =N [3]

- (b) The variation with distance r of the potential energy E_p may be represented by the expression

$$E_p = -\frac{A}{r} + \frac{B}{r^8}$$

where A and B are constants.

By reference to Fig. 7.2, state two features of the force represented by the term $\frac{B}{r^8}$ in this expression.

1.

 2.
 [2]

(c) Fig. 7.3 shows part of Fig. 7.2, drawn on a larger scale.

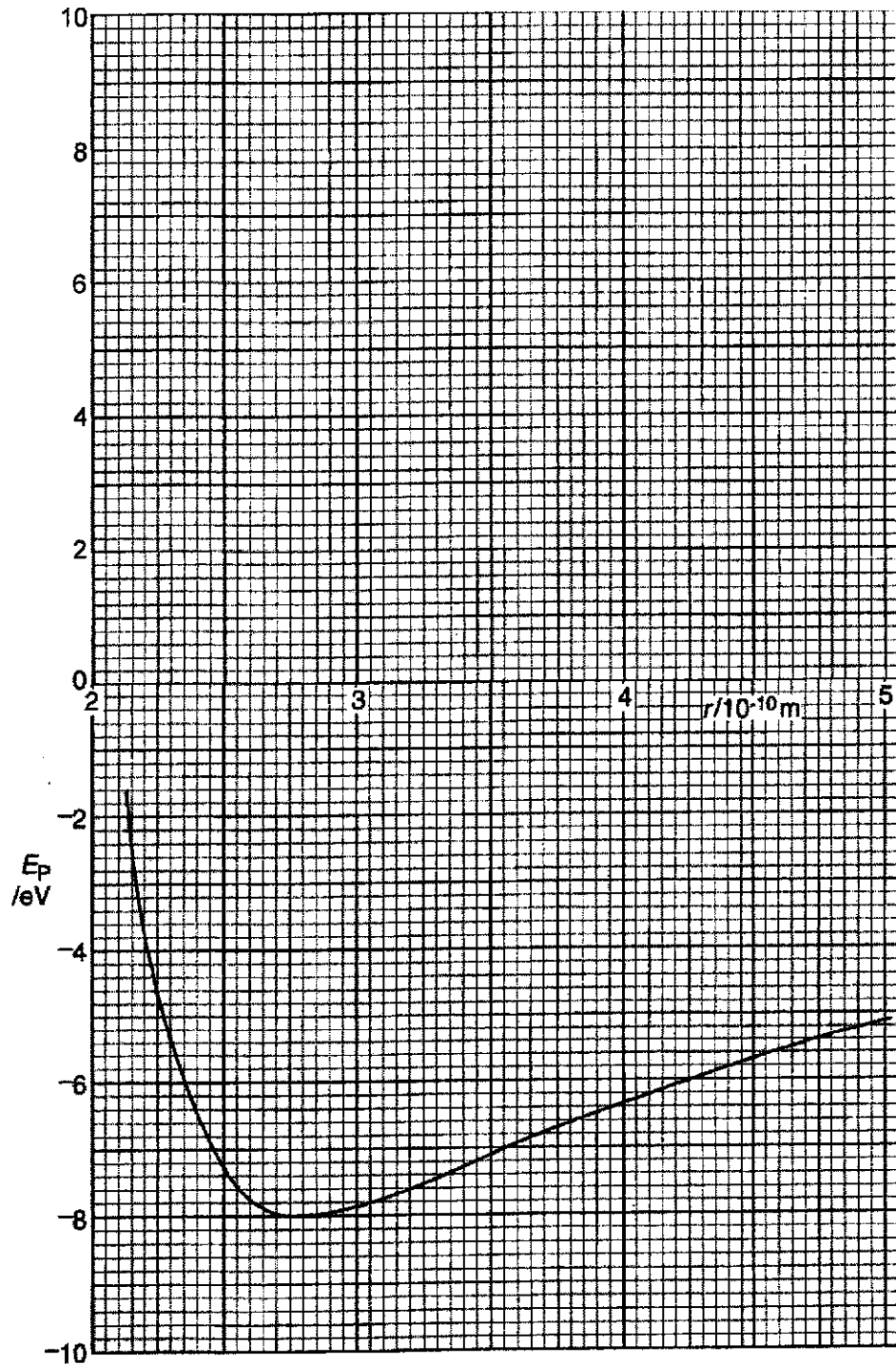

Fig. 7.3

Thermal energy of the ions causes them to vibrate.
The ions have a total energy of -6.0 eV.

(i) On Fig. 7.3,

1. draw the variation with the distance r of the total energy of the ions. Label the line T. [1]
2. draw the variation with the distance r of the kinetic energy of the ions. Label the line K. [2]

(ii) Use Fig. 7.3 to determine, for these ions, the values of r between which they vibrate.

minimum value of $r = \dots\dots\dots$ m

maximum value of $r = \dots\dots\dots$ m [2]

(iii) State and explain whether the oscillations of the ions are simple harmonic.

.....
.....
..... [2]

(d) By reference to Fig. 7.3, suggest why the dimensions of the whole lattice increase as it is heated.

.....
.....
.....
..... [3]

[Total: 20]

BLANK PAGE

Name: _____ ()

Class: 19 / _____



ANDERSON SERANGOON JUNIOR COLLEGE

2019 JC2 Preliminary Examination

PHYSICS Higher 2

9749/03

Paper 3 Longer Structured Questions

Thursday 29 August 2019

2 hours

Candidates answer on the Question Paper.
No Additional Materials are required.

READ THESE INSTRUCTIONS FIRST

Write your name, class index number and class in the spaces provided above.
Write in dark blue or black pen on both sides of the paper.
You may use an HB pencil for any diagrams or graphs.

The use of an approved scientific calculator is expected, where appropriate.

Section A

Answer **all** questions.

Section B

Answer **one** question only.

You are advised to spend about one and a half hours on Section A and half an hour on Section B.

At the end of the examination, fasten all your work securely together.

The number of marks is given in brackets [] at the end of each question or part question.

For Examiner's Use	
Paper 3 (80 marks)	
1	
2	
3	
4	
5	
6	
7	
8	
9	
Significant Figure	
Total	

This document consists of **22** printed pages and **2** blank pages.

9749/03/ASRJC/2019PRELIM

[Turn Over

Data

speed of light in free space	$c = 3.00 \times 10^8 \text{ m s}^{-1}$
permeability of free space	$\mu_0 = 4\pi \times 10^{-7} \text{ H m}^{-1}$
permittivity of free space	$\epsilon_0 = 8.85 \times 10^{-12} \text{ F m}^{-1}$ $(1/(36\pi)) \times 10^{-9} \text{ F m}^{-1}$
elementary charge	$e = 1.60 \times 10^{-19} \text{ C}$
the Planck constant	$h = 6.63 \times 10^{-34} \text{ J s}$
unified atomic mass constant	$u = 1.66 \times 10^{-27} \text{ kg}$
rest mass of electron	$m_e = 9.11 \times 10^{-31} \text{ kg}$
rest mass of proton	$m_p = 1.67 \times 10^{-27} \text{ kg}$
molar gas constant	$R = 8.31 \text{ J K}^{-1} \text{ mol}^{-1}$
the Avogadro constant	$N_A = 6.02 \times 10^{23} \text{ mol}^{-1}$
the Boltzmann constant	$k = 1.38 \times 10^{-23} \text{ J K}^{-1}$
gravitational constant	$G = 6.67 \times 10^{-11} \text{ N m}^2 \text{ kg}^{-2}$
acceleration of free fall	$g = 9.81 \text{ m s}^{-2}$

Formulae

uniformly accelerated motion

$$s = ut + \frac{1}{2}at^2$$

$$v^2 = u^2 + 2as$$

work done on/by a gas

$$W = p\Delta V$$

hydrostatic pressure

$$p = \rho gh$$

gravitational potential

$$\phi = -\frac{Gm}{r}$$

temperature

$$T/K = T/^\circ\text{C} + 273.15$$

pressure of an ideal gas

$$p = \frac{1}{3} \frac{Nm}{V} \langle c^2 \rangle$$

mean translational kinetic energy of an ideal gas molecule

$$E = \frac{3}{2}kT$$

displacement of particle in s.h.m.

$$x = x_0 \sin \omega t$$

velocity of particle in s.h.m.

$$v = v_0 \cos \omega t$$

$$= \pm \omega \sqrt{x_0^2 - x^2}$$

electric current

$$I = Anvq$$

resistors in series

$$R = R_1 + R_2 + \dots$$

resistors in parallel

$$1/R = 1/R_1 + 1/R_2 + \dots$$

electric potential

$$V = \frac{Q}{4\pi\epsilon_0 r}$$

alternating current/voltage

$$x = x_0 \sin \omega t$$

magnetic flux density due to a long straight wire

$$B = \frac{\mu_0 I}{2\pi d}$$

magnetic flux density due to a flat circular coil

$$B = \frac{\mu_0 NI}{2r}$$

magnetic flux density due to a long solenoid

$$B = \mu_0 nI$$

radioactive decay

$$x = x_0 \exp(-\lambda t)$$

decay constant

$$\lambda = \frac{\ln 2}{t_{\frac{1}{2}}}$$

Section A

Answer **all** the questions in this section in the spaces provided.

- 1 (a) An object travelling in a circle of radius r at constant speed v is accelerating. By drawing a vector diagram to show the combination of vectors, explain how this is possible.

.....

 [2]

- (b) A rider of mass 60 kg was confined in a Rotor, an amusement park ride. The Rotor is a large vertical barrel, rotated about a vertical axis through its centre. The radius of the barrel is 2.5 m. When the barrel is rotated sufficiently fast, the floor is dropped and the rider is stuck to the wall of the barrel.

- (i) Fig. 1.1 shows a side-view of the position of a rider when the floor was dropped. Draw arrows to show the forces acting on the rider and label the forces clearly.

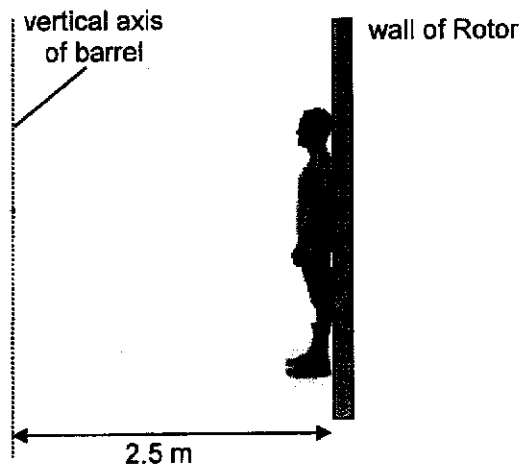

Fig. 1.1 (not drawn to scale) [2]

- (ii) Explain why the rider is able to go around in a circle without falling off.

.....

 [2]

9749/03/ASRJC/2019PRELIM

- (iii) The barrel in part (i) is rotating at 33 revolutions per minute.
Calculate the acceleration of the rider.

acceleration =m s⁻² [2]

- (iv) State and explain the amount of work done on the rider throughout the acceleration in part (iii).

.....

[2]

[Total 10]

- 2 (a) State the first law of thermodynamics.

.....
[1]

- (b) An ideal gas is placed in an insulated cylinder as shown in Fig. 2.1.

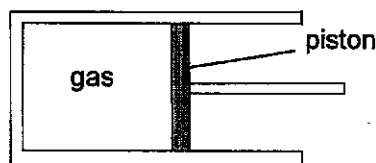

Fig 2.1

Initially, its pressure is 1.04×10^5 Pa and its temperature is 314 K. 28.5 J of heat is then supplied to the gas, causing its volume to increase from 2.90×10^{-4} m³ to 4.00×10^{-4} m³ while keeping its pressure constant.

- (i) Calculate the work done on the gas.

work done on gas = J [2]

(ii) Show that the change in internal energy of the gas is 17.1 J.

[1]

(iii) Calculate the new temperature of the gas.

new temperature = K [2]

(iv) Calculate the ratio of the final root-mean-square (r.m.s.) speed to the original r.m.s. speed of the molecules.

ratio = [2]

[Total 8]

3 (a) Distinguish between transverse and longitudinal waves.

.....
.....
.....[2]

(b) Particle A and particle B oscillate on the same wave.

Fig 3.1 shows the variation with time of the displacement for particle A and particle B.

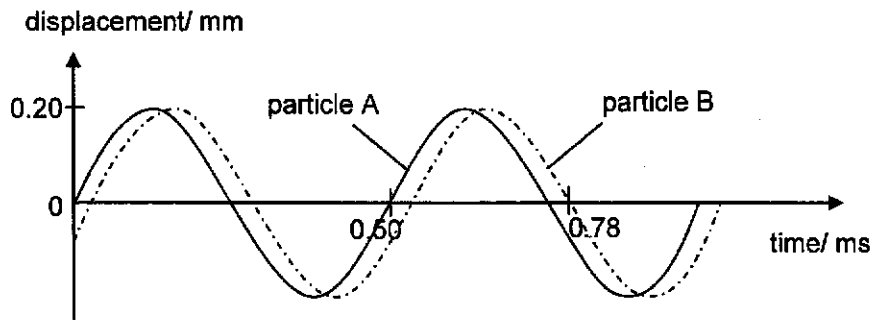

Fig. 3.1 (not drawn to scale)

(i) Calculate the phase angle between the two particles A and B.

phase angle =° [2]

(ii) The wave on which the particles oscillate travels to the right.

Sketch on the axes of Fig. 3.2 the variation with distance of displacement for the wave at time $t = 0$. The position of particle A is shown on the axes.

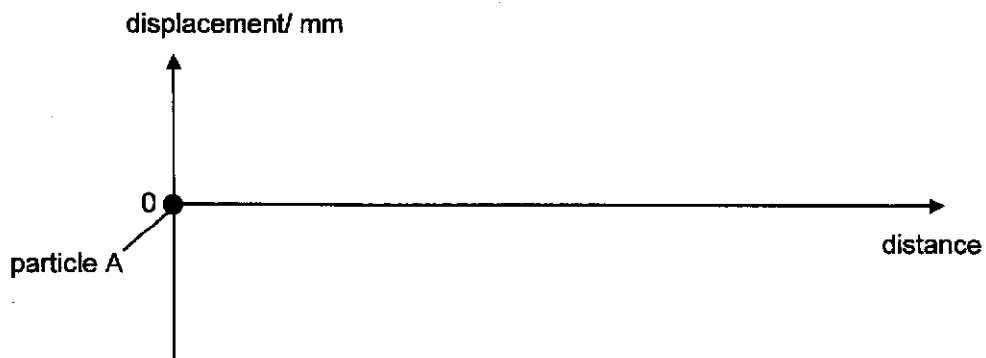

Fig. 3.2

[2]

[Total 6]

- 4 (a) An electric lamp has a resistance of 960Ω . The filament of the lamp is made from tungsten that has a resistivity of $7.9 \times 10^{-7} \Omega \text{ m}$. The diameter of the filament is $12.0 \times 10^{-6} \text{ m}$.

Calculate the length of the filament.

length = m [2]

- (b) Fig. 4.1 shows the variation with voltage V of the current I across a thermistor.

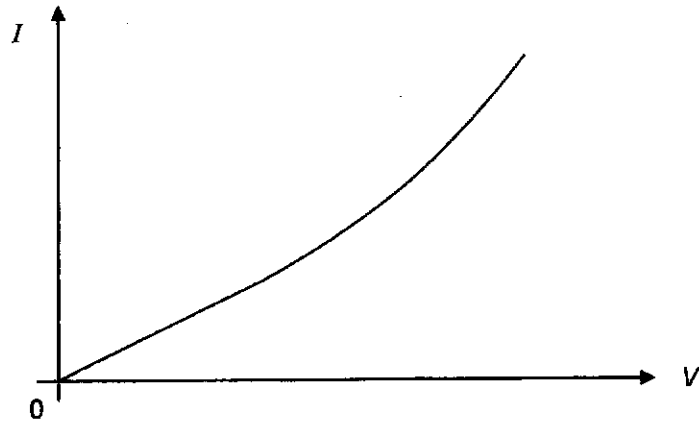

Fig. 4.1

- (i) State how the resistance of the thermistor can be determined from Fig 4.1.

.....
.....[1]

- (ii) In microscopic terms, explain why the resistance of the thermistor decreases as V increases.

.....
.....
.....
.....
.....
.....
.....
.....
.....
.....[3]

- 5 Two small charged metal spheres A and B are situated in a vacuum. The distance between the centres of the spheres is 12.0 cm, as shown in Fig. 5.1.

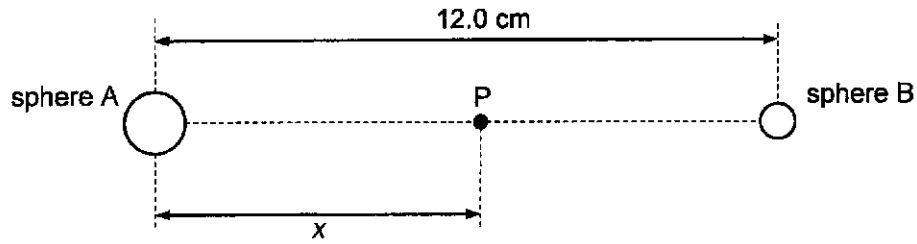

Fig. 5.1

The charge on each sphere may be assumed to be a point charge at the centre of the sphere. Point P is a movable point that lies on the line joining the centres of the spheres and is distance x from the centre of sphere A.

The variation with distance x of the electric field strength E at point P is shown in Fig. 5.2.

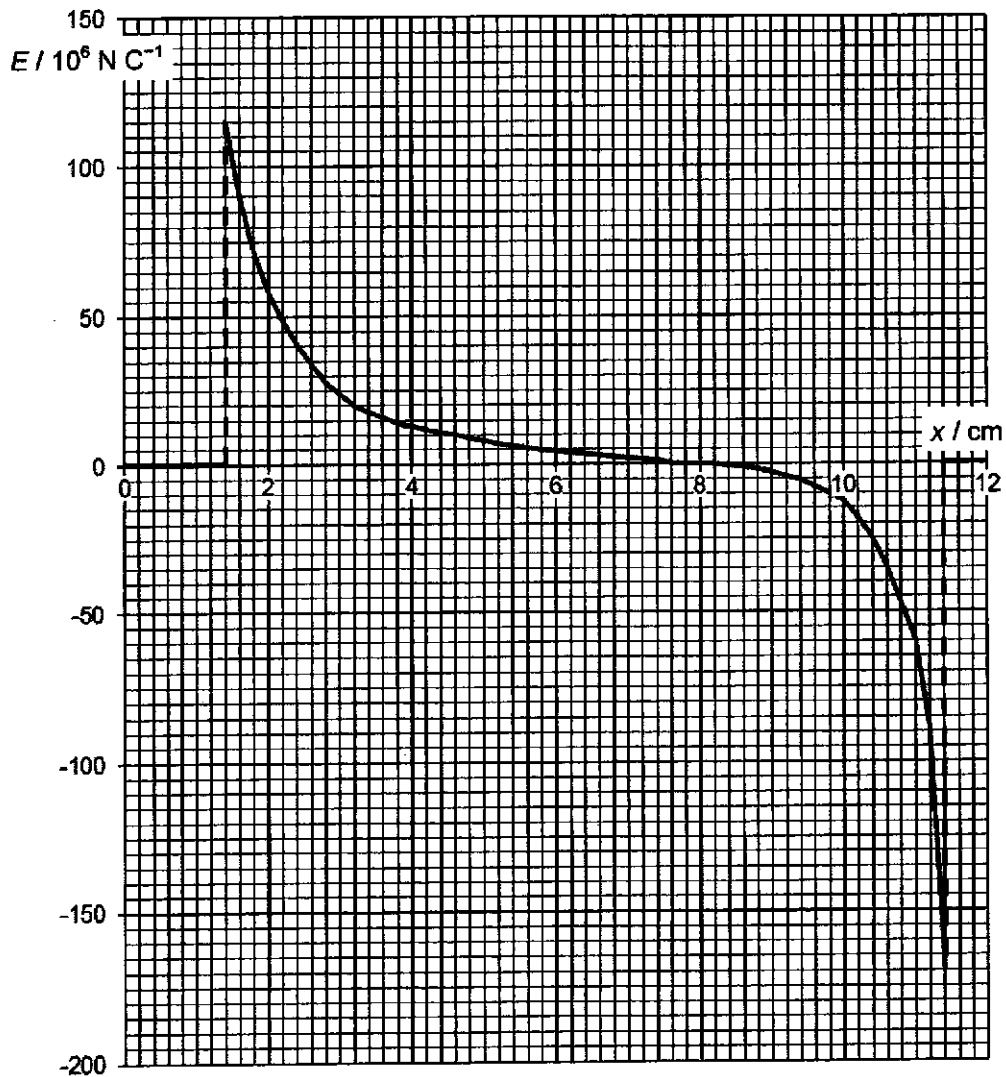

Fig. 5.2

9749/03/ASRJC/2019PRELIM

(a) State the evidence provided by Fig. 5.2 that the spheres are conductors.

.....
..... [1]

(b) (i) State and explain, whether the polarity of the charges on the spheres are of the same sign.

.....
.....
.....
..... [2]

(ii) Use Fig. 5.2 to determine the ratio $\frac{\text{charge on sphere A}}{\text{charge on sphere B}}$.

ratio = [3]

(iii) Hence, on Fig. 5.3, sketch the electric field lines due to these two charges.



Fig. 5.3

[2]

[Total 8]

[Turn Over

- 6 (a) A uniform magnetic field has constant flux density B . A straight wire of fixed length carries a current I at an angle θ to the magnetic field, as shown in Fig. 6.1.

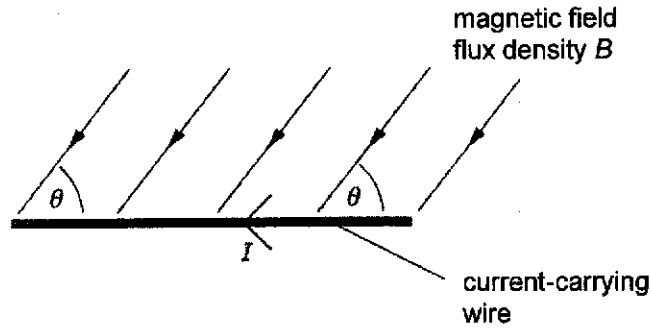

Fig. 6.1

- (i) The current I in the wire is changed, keeping the angle θ constant. On Fig. 6.2, sketch a graph to show the variation with current I of the force F on the wire.

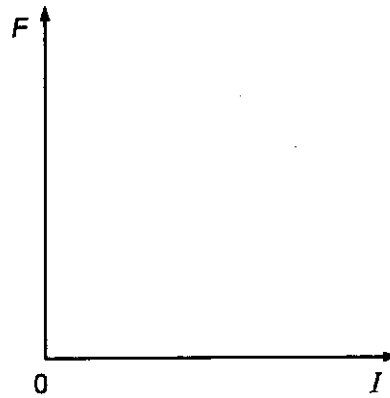

Fig. 6.2

[2]

- (ii) The angle θ between the wire and the magnetic field is now varied. The current I is kept constant. On Fig. 6.3, sketch a graph to show the variation with angle θ of the force F on the wire. F_{max} is the maximum force acting on the wire.

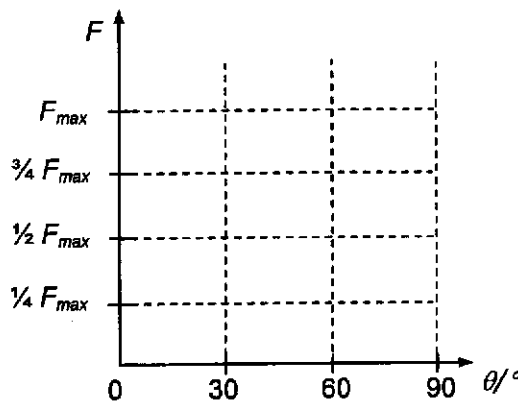

Fig. 6.3

[3]

- (b) A uniform magnetic field is directed at right-angles to the rectangular surface PQRS of a slice of a conducting material, as shown in Fig. 6.4.

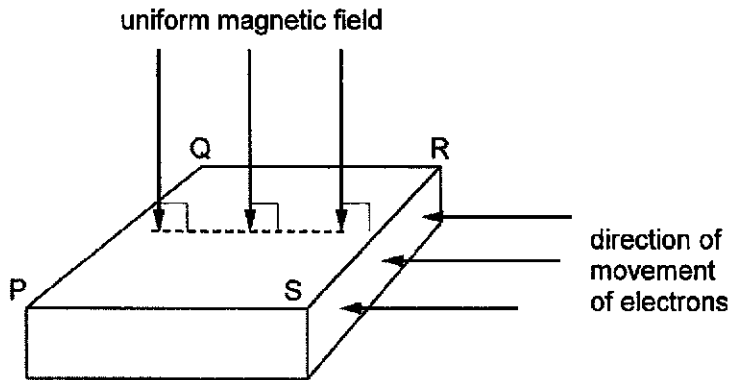

Fig. 6.4

Electrons, moving towards the side SR, enter the slice of conducting material. The electrons enter the slice at right-angles to side SR.

- (i) The electrons initially do not travel in straight lines across the slice from side SR to side PQ.

State and explain to which side, PS or QR, the electrons tend to move.

.....

 [2]

- (ii) Subsequent electrons travel undeflected in straight lines across the slice from side SR to side PQ.

Explain why this happens.

.....

 [2]

[Total 9]

7 The variation with time t of the current I in a resistor is shown in Fig. 7.1.

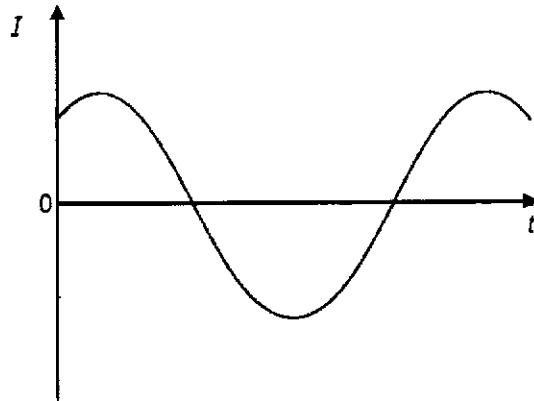

Fig. 7.1

The variation of the current with time is sinusoidal.

(a) (i) Explain why, although the mean current is zero, power is dissipated in the resistor.

.....
 [1]

(ii) Using the relation between root-mean-square (r.m.s.) current and peak current, deduce the value of the ratio

$$\frac{\text{average power dissipated in the resistor}}{\text{maximum power dissipated in the resistor}}$$

ratio = [2]

(b) A simple iron-cored transformer is illustrated in Fig. 7.2.

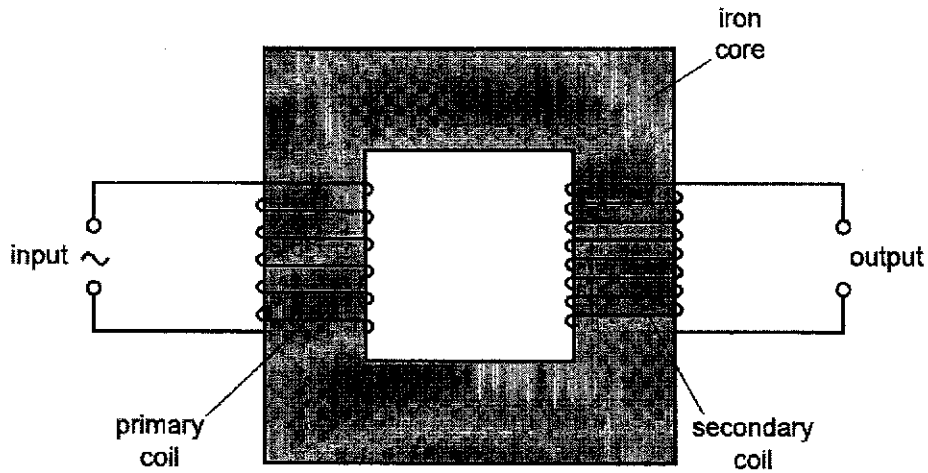

Fig. 7.2

(i) State why the primary and secondary coils are wound on a core made of soft iron.

.....
..... [1]

(ii) Explain why thermal energy is generated in the core when the transformer is in use.

.....
.....
.....
..... [2]

(iii) State a typical feature in the design of the iron core to reduce power loss.

..... [1]

[Total 7]

Section B

Answer **one** question from this Section in the spaces provided.

- 8 (a) (i) The distance s moved by an object in time t may be given by the expression

$$s = \frac{1}{2}at^2$$

where a is the acceleration of the object.

State two conditions for this expression to apply to the motion of the object.

1.

 2.
 [2]

- (ii) A student takes a photograph of a steel ball of radius 5.0 cm as it falls from rest. The image of the ball is blurred, as illustrated in Fig. 8.1. The image is blurred because the ball is moving while the photograph is being taken.

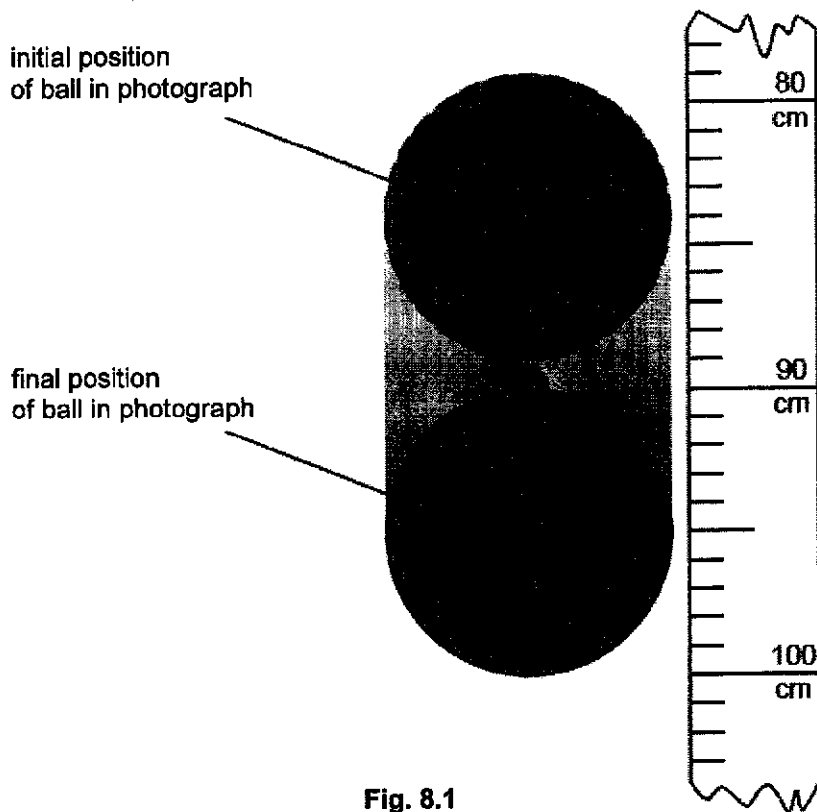

Fig. 8.1

The scale shows the distance fallen from rest by the ball. At time $t = 0$, the top of the ball is level with the zero mark on the scale. Air resistance is negligible.

1. Calculate the time the ball falls before the photograph is taken,

time =s [2]

2. Calculate the time interval T during which the photograph is taken.

$T = \dots\dots\dots$ s [2]

3. The time for which the shutter stays open is marked as $\frac{1}{30}$ s.
Comment on whether your answer in (ii)2. confirms this time.

.....
..... [2]

- (iii) The student in (ii) takes a second photograph starting at the same position on the scale. The ball has the same radius but is less dense, so that air resistance is not negligible.

State and explain the changes that will occur in the photograph.

.....
.....
.....
..... [2]

(b) (i) State the relation between force and momentum.

..... [1]

(ii) A rigid bar of mass 450 g is held horizontally by two supports A and B, as shown in Fig. 8.2.

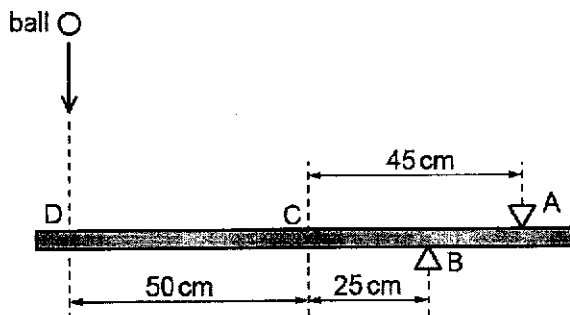

Fig. 8.2

The support A is 45 cm from the centre of gravity C of the bar and support B is 25 cm from C.

A ball of mass 140 g falls vertically onto the bar such that it hits the bar at point D, a distance of 50 cm from C, as shown in Fig. 8.2.

The variation with time t of the velocity v of the ball before, during and after hitting the bar is shown in Fig. 8.3.

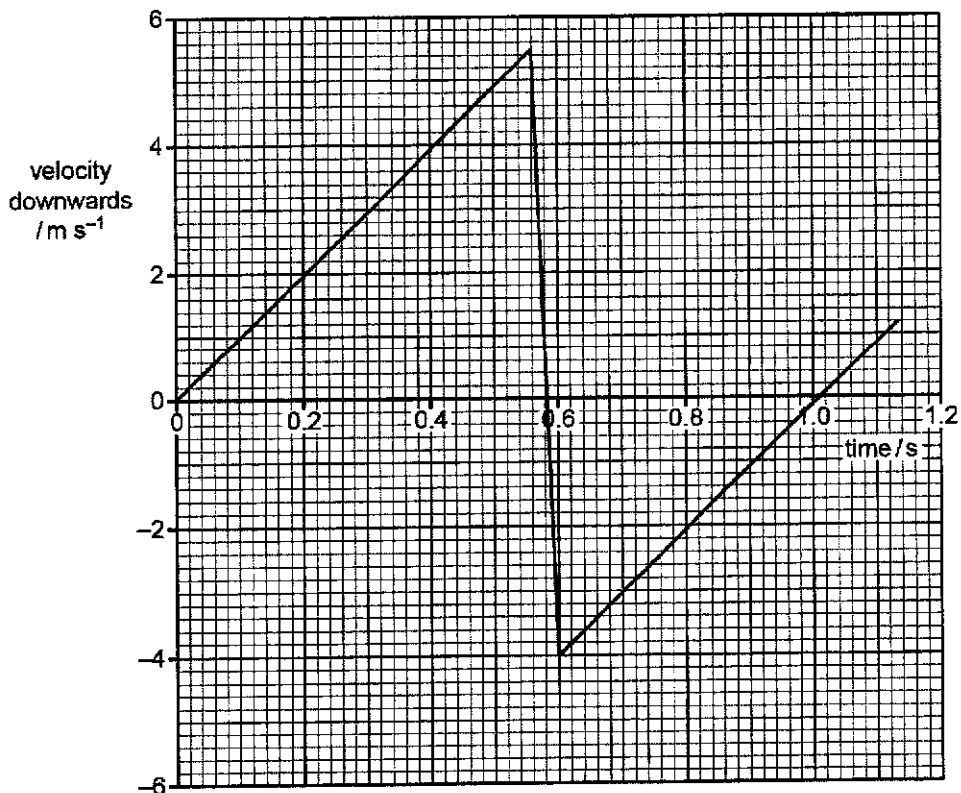

Fig. 8.3

For the time that the ball is in contact with the bar, use Fig. 8.2 and 8.3

1. to determine the change in momentum of the ball,

change in momentum =kg m s⁻¹ [2]

2. to show that the magnitude of the average force exerted by the ball on the bar is 35 N,

[2]

3. to calculate the average force exerted on the bar by the support A.

force =N [3]

- (iii) The bar is now cushioned with a light sponge at point D.

State and explain the effect on your answer to (b)(ii)3 when the ball makes contact with the bar.

.....
.....
.....
..... [2]

[Total 20]

- 9 (a) State what is meant by *half-life*.

.....

 [2]

- (b) A stationary radioactive isotope P decays by emitting a β -particle and γ -radiation. The daughter nucleus produced during this decay is Q. An incomplete equation to represent this decay is



The variation with time t of the number N of undecayed nuclei of radioactive sample of isotope P is shown in Fig. 9.1.

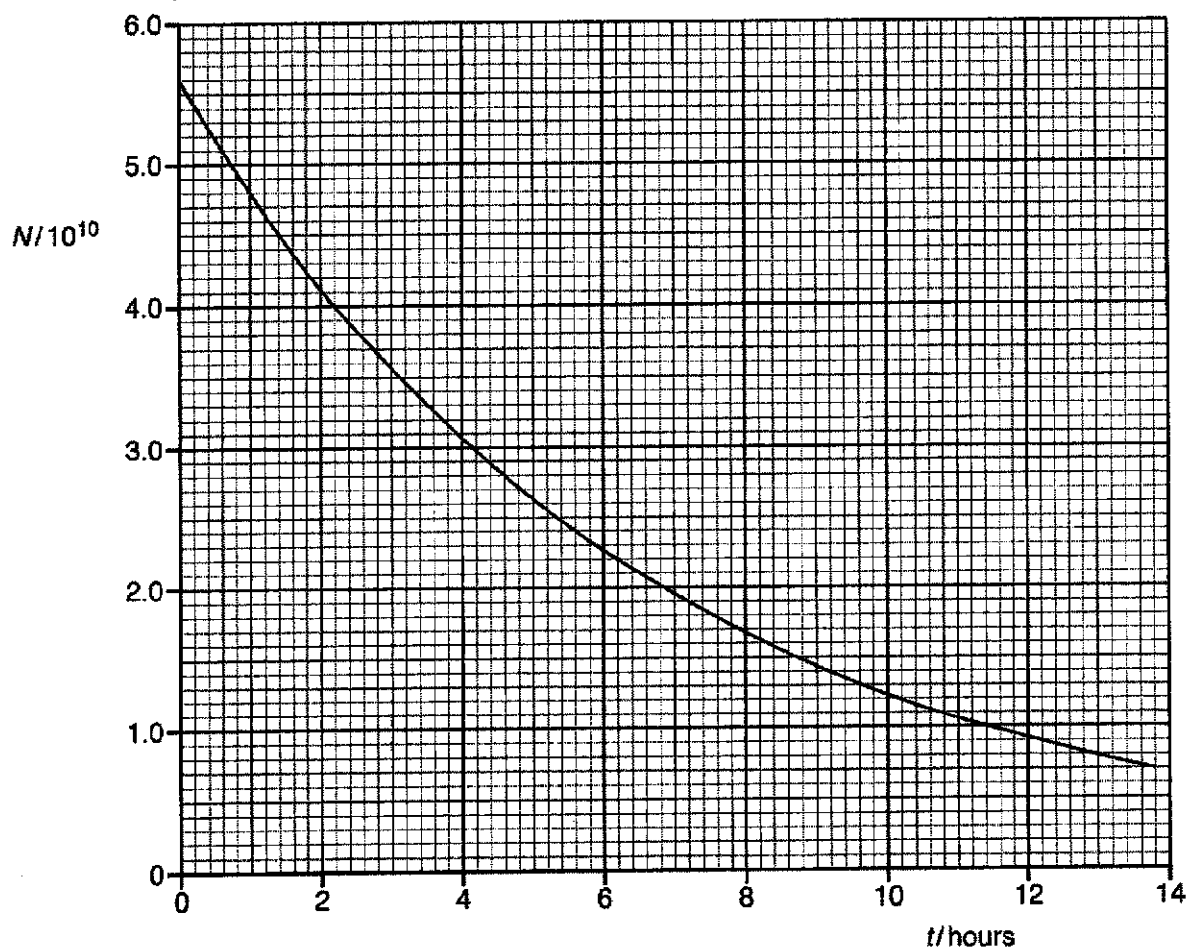

Fig. 9.1

- (i) Use Fig. 9.1 to estimate the half-life of isotope P.

half-life =hours [2]

9749/03/ASRJC/2019PRELIM

- (ii) Initially, there are no Q nucleus in the sample.
 After a period of time t , the ratio $\frac{\text{number of Q nuclei}}{\text{number of P nuclei}}$ equals 6.
 Calculate t .

$t = \dots\dots\dots$ hours [2]

- (iii) State the significance of the gradient of the graph.

.....
 [1]

- (iv) Determine the activity of isotope P at $t = 4.0$ hours.

activity =Bq [3]

- (v) The daughter nucleus Q is stable. On Fig. 9.1, sketch a graph to show the variation with time t of the number of daughter nuclei Q in the sample. [2]

- (vi) State and explain why the sum of the kinetic energy of the β -particle and the energy of the γ -radiation is less than the total energy released during the decay of isotope P.

.....

 [3]

- (c) Isotope P is produced in a laboratory by bombarding a stationary nucleus S with an α -particle. It results in the following nuclear reaction.

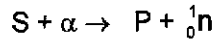

Fig. 9.2 shows the position of isotope P on a diagram in which nucleon number is plotted against proton number. Each small square represents a unit increase in the nucleon number and proton number in the direction of the axes.

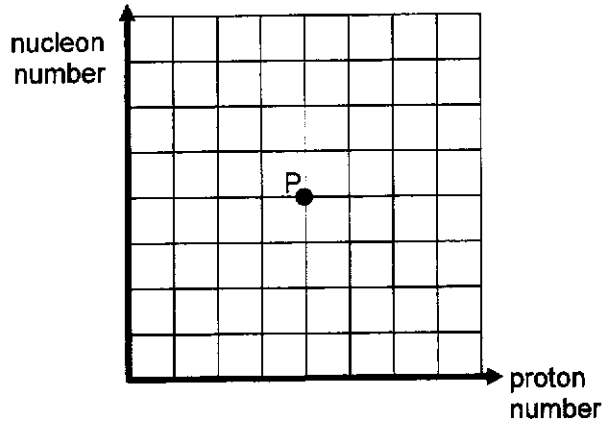

Fig. 9.2

- (i) On Fig. 9.2, mark with the symbol S the position of the nuclide S. [1]
- (ii) With reference to (b), mark on Fig. 9.2 with the symbol Q the position of the daughter nuclide Q due to the decay of isotope P. [1]
- (d) Fig. 9.3 shows an α -particle approaching a stationary gold nucleus head-on. The distance of closest approach of the α -particle to the nucleus S is d .

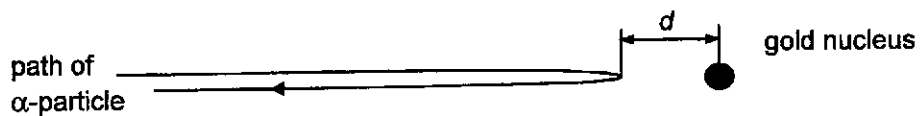

Fig. 9.3

At its distance of closest approach d , explain whether it is possible for the gold nucleus and the α -particle to be at rest simultaneously.

.....

.....

.....

.....[3]

[Total 20]

BLANK PAGE

BLANK PAGE

List of apparatus

Question 1

- 1 marble
- 1 ramp (Do not bend the ramp) (see notes below)
- 1 wooden block
- 1 plastic tray with sand (see notes below)
- 1 retort stand, boss and clamp
- 1 30 cm ruler
- 1 metre rule
- 1 protractor

Question 2

- 1 spring (with string tied on one end)
- 1 split cork
- 1 pin
- 1 metre rule with one hole at one end
- 2 retort stands (with boss and clamp)
- 1 string
- 1 350 g mass
- 1 stopwatch

Question 3

- 1 battery
- 1 switch
- 1 digital multimeter (set to DC 20 mA)
- 1 R_1
- 3 $100\ \Omega$ resistors
- 8 connecting wires
- 1 analogue voltmeter

The apparatus should be laid out on the bench. If the apparatus is to be used by a second candidate, then it should be restored to its original state.

Notes

- 1 Use the wire and tape to make a track for the spheres to roll on:
 - Place a length of tape on the bench with the sticky side facing up.
 - Make sure the wires are straight and then press them onto the tape parallel to each other and approximately 1.0 cm apart.
 - Press another length of tape (sticky side down) on top of the wires.
 - Trim excess tape from the ends to give the appearance of Fig. 2.1.

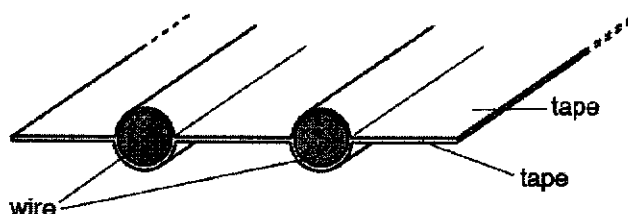

Fig. 2.1 (not to scale)

Bend the track to make a ramp with a shape similar to that shown in Fig. 2.2.

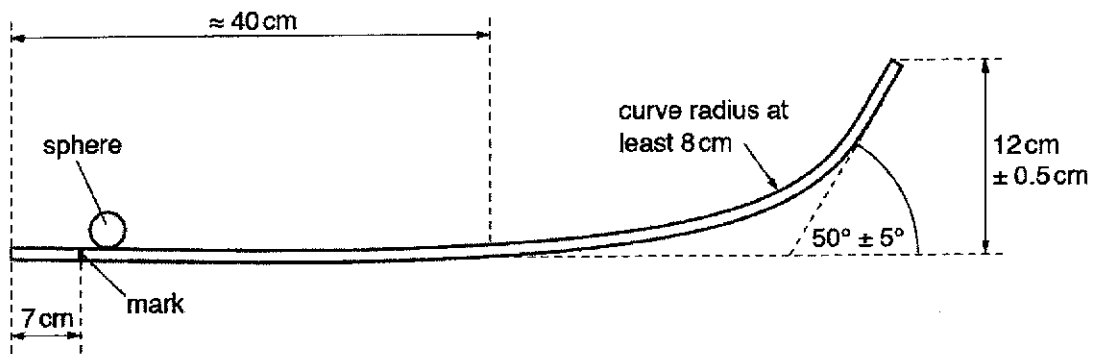

Fig. 2.2 (not to scale)

Make a small mark on each side of the track 7 cm from the end, as shown in Fig. 2.2.

- 2 Add sand to the tray to give a depth of approximately 1 cm.
- 3 The apparatus should be laid out on the bench. If the apparatus is to be used by a second candidate, then it should be restored to its original state.

Name: _____ ()

Class: 19 /



ANDERSON SERANGOON JUNIOR COLLEGE

2019 JC2 Preliminary Examination

PHYSICS Higher 2

9749/04

Paper 4 Practical

Monday 2 September 2019

2 hours 30 minutes

Candidates answer on the Question Paper.

Additional Materials: As listed on the Confidential Instructions

READ THESE INSTRUCTIONS FIRST

Write your name, class index number and class in the spaces provided above.

Write in dark blue or black pen on both sides of the paper.

You may use an HB pencil for any diagrams, graphs or rough working.

Do not use staples, paper clips, glue or correction fluid.

Answer all questions.

Write your answers in the spaces provided on the question paper.

The use of an approved scientific calculator is expected, where appropriate.

You may lose mark if you do not show your working or if you do not use appropriate units.

Give details of the practical shift and laboratory where appropriate in the boxes provided.

At the end of the examination, fasten all your work securely together.

The number of marks is given in brackets [] at the end of each question or part question.

Shift
Laboratory

For Examiner's Use	
Paper 4 (55 marks)	
1	
2	
3	
4	
Total (55 marks)	

This document consists of 15 printed pages and 5 blank pages.

9749/04/ASRJC/2019/Prelim

[Turn Over

1 In this experiment, you will investigate the motion of a sphere launched from a ramp.

For
Examiner's
Use

- (a) Set up the apparatus as shown in Fig. 1.1. Adjust the height of the clamp so that the launch angle ϕ is approximately 15° . Do not bend the ramp throughout the experiment.

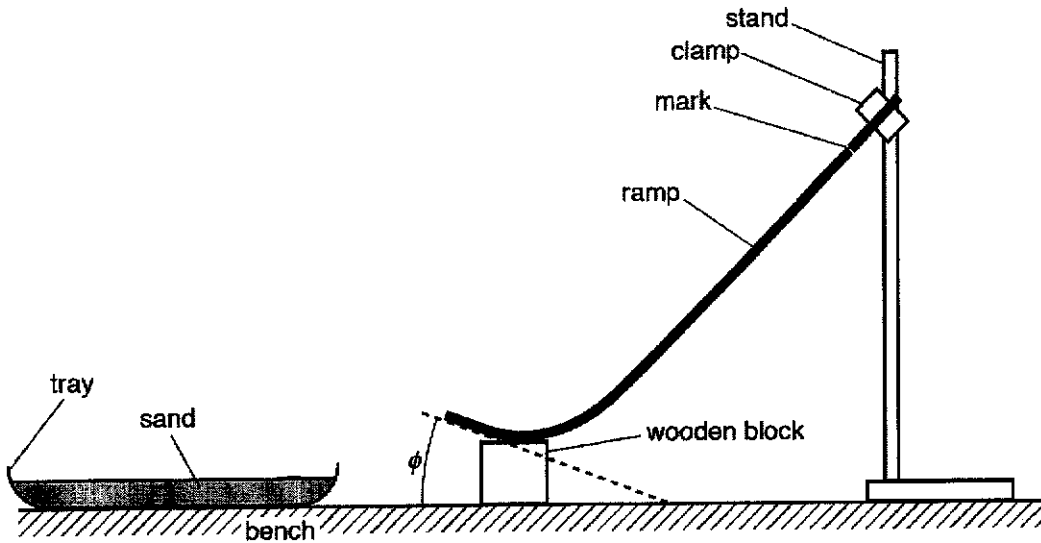

Fig. 1.1 (not to scale)

- (b) (i) Measure and record ϕ , as shown in Fig. 1.1.

$\phi = \dots\dots\dots$ [1]

M1	
----	--

- (ii) Measure and record the height h_1 of the mark above the bench, as shown in Fig. 1.2.

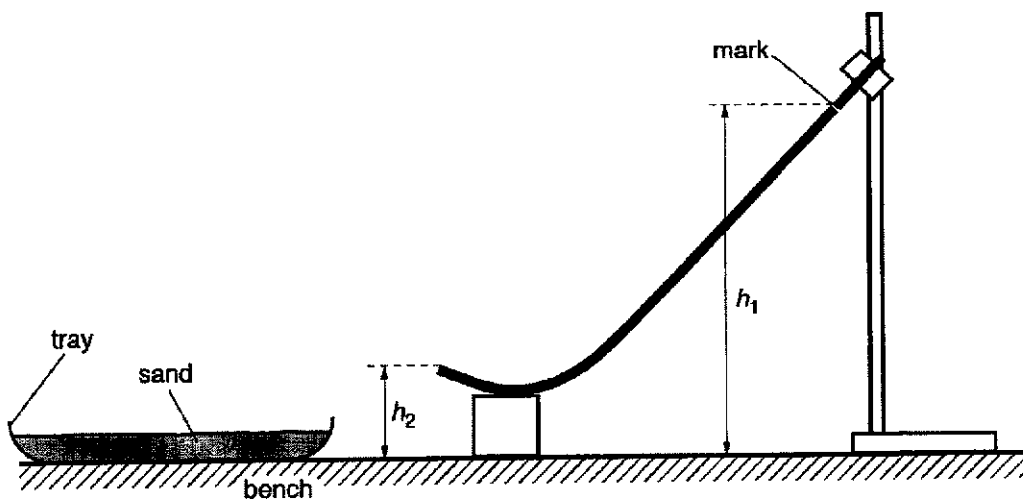

Fig. 1.2 (not to scale)

$h_1 = \dots\dots\dots$

(iii) Measure and record the height h_2 of the end of the ramp, as shown in Fig. 1.2.

$h_2 = \dots\dots\dots$ [1]

For Examiner's Use

M2	
----	--

(iv) Calculate the speed v of the sphere when it leaves the ramp using the expression

$$v = \sqrt{2g(h_1 - h_2)}$$

where $g = 9.81 \text{ m s}^{-2}$.

$v = \dots\dots\dots$ [1]

A1	
----	--

(c) Justify the number of significant figures you have given for your value of v .

.....
 [1]

P1	
----	--

- (d) (i) Place the sphere on the ramp at the mark. Release the sphere.
 (ii) Measure and record the horizontal distance R from the end of the ramp to the landing position of the sphere, as shown in Fig. 1.3.

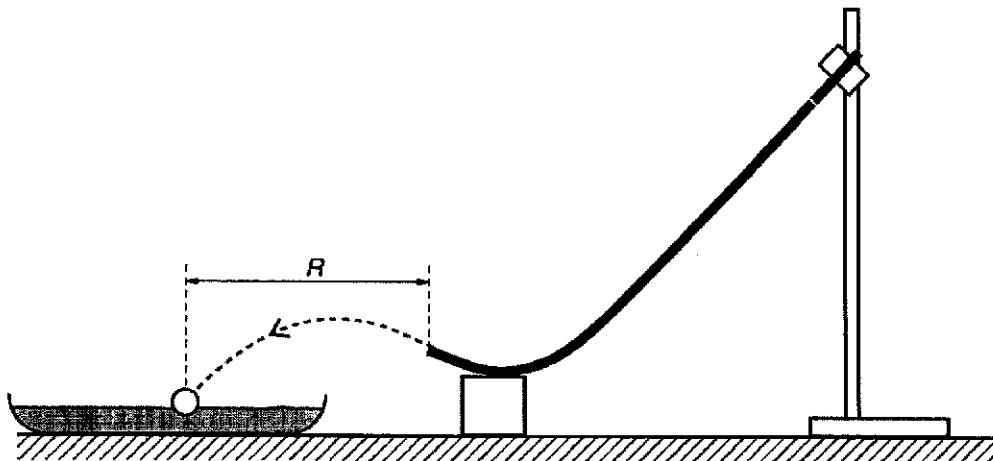

Fig. 1.3 (not to scale)

$R = \dots\dots\dots$ [2]

M3	
M4	

- (e) Estimate the percentage uncertainty in your value of R .

For
Examiner's
Use

percentage uncertainty = [1]

A2	
----	--

- (f) By lowering the clamp, increase the launch angle ϕ to approximately 25° . Repeat (b) and (d) using the sphere.

$\phi =$

$h_1 =$

$h_2 =$

$v =$

$R =$ [2]

M5	
M6	

(g) It is suggested that the relationship between R , v and ϕ is

$$R = k v \cos \phi$$

where k is a constant.

(i) Using your data, calculate two values of k .

first value of k =

second value of k =

[1]

A3	
----	--

(ii) Explain whether your results support the suggested relationship.

.....
.....
.....[1]

A4	
----	--

(iii) It is not accurate to draw a conclusion based on only two readings as in g(ii). Suggest a way the method can be changed.

.....
.....
.....[1]

A5	
----	--

For
Examiner's
Use

Question 2 begins on the next page.

- 2 In this experiment, you will investigate the oscillatory motion of a loaded metre rule supported at one end by a spring.

For
Examiner's
Use

- (a) Secure the cork in the clamp so that the pin is mounted horizontally. Suspend one end of the rule from the pin by passing the pin through the hole in the rule. The rule should be able to pivot around the pin.

Hook one end of the spring to the rod of another clamp. Suspend the other end of the rule through the small loop of string. The string should be at the 0.5 cm marking of the rule as shown in Fig. 2.1.

The clamps should be adjusted so that the rule is approximately horizontal.

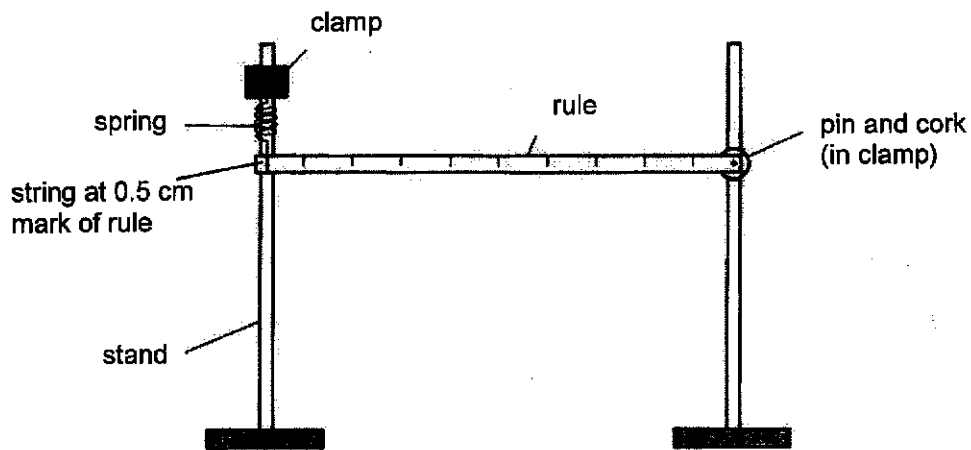

Fig. 2.1

- (b) Tie a loop of string on the rule to suspend a mass of 350 g a distance d from the pin as shown in Fig. 2.2. The mass should be about halfway along the rule. Adjust the position of the clamps to make the rule approximately horizontal again.

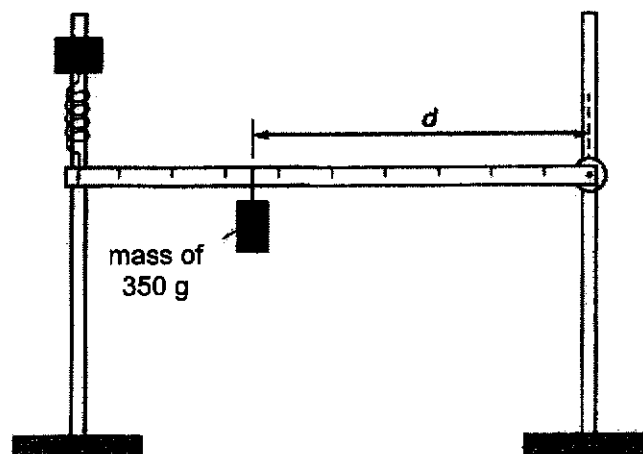

Fig. 2.2

- (c) Measure and record the value of d .

$d = \dots\dots\dots$

- (d) Gently displace the end of the rule so that it performs small oscillations in a vertical plane.

Determine the period T of the oscillations.

$T = \dots\dots\dots$ [2]

For
Examiner's
Use

M1	
A1	

- (e) The equation that relates T and d for this oscillator is

$$T^2 = \frac{4\pi^2}{kL^2} (Md^2 + C)$$

where k is 28.0 N m^{-1} , M is the mass of the load, L is the length of the rule and C is a constant.

Calculate C .

$C = \dots\dots\dots$ [3]

A2	
A3	
A4	

[Total: 5]

Question 3 begins on the next page.

- 3 In this experiment, you will investigate how the current through a milliammeter varies as the resistance of a resistor is changed.

For
Examiner's
Use

- (a) Set up the circuit as shown in Fig. 3.1.

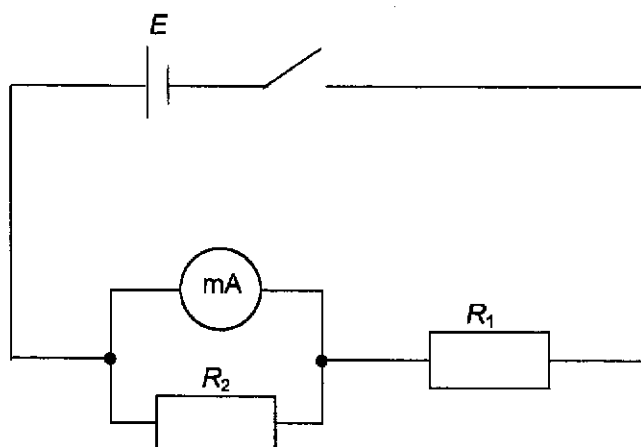

Fig. 3.1

- (b) The resistor of resistance R_2 can be made using any combination of the resistors provided. The resistance of each resistor is $100\ \Omega$.
- (c) Set the value of R_2 to $100\ \Omega$ and close the switch. Record the current I through the digital milliammeter.

$I = \dots\dots\dots\text{A}$ [1]

M1	
----	--

- (d) Change the value of R_2 and repeat step (c) to obtain further sets of values for R_2 , and the corresponding values of I .

For
Examiner's
Use

M2	
M3	
P1	
P2	
P3	
A1	

[7]

- (e) It is suggested that I and R_2 are related by the equation,

$$\frac{1}{I} = \frac{k}{R_2} + C$$

where k and C are constants.

Plot a suitable graph to determine values of k and C .

$k = \dots\dots\dots$

$C = \dots\dots\dots$

[7]

A2	
A3	
A4	
A5	

For
Examiner's
Use

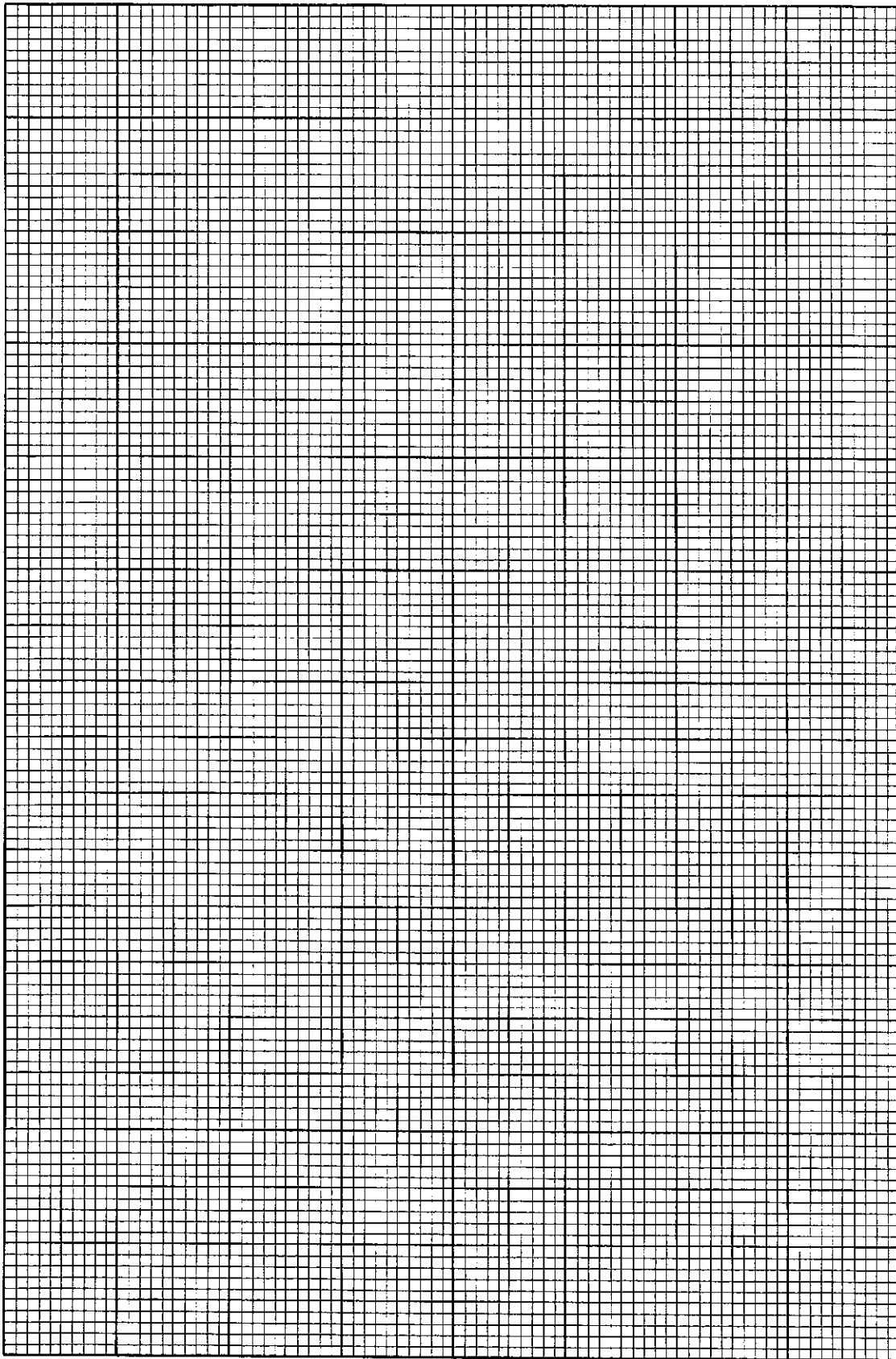

P4	
P5	
P6	

For
Examiner's
Use

- (f) (i) Comment on any anomalous data or results you may have obtained. Explain your answer.

.....
 [1]

M4	
----	--

- (ii) Measure and record a value of the e.m.f. E of the power supply using the analogue voltmeter.

$E = \dots\dots\dots$ [1]

M5	
----	--

- (g) Theory suggests that $k = \frac{R_1 S}{E}$

where S is the resistance of the digital milliammeter.

Given that $R_1 = 470 \Omega$, together with your answers to (e) and (f)(ii), determine a value for S .

$S = \dots\dots\dots$ [1]

A6	
----	--

- (h) C is inversely proportional to E .

On the graph grid on page 13, sketch a second graph to represent the results if E is increased. Label this graph Z.

[2]

A7	
A8	

[Total: 20]

Question 4 begins on the next page.

- 4 Two identical light sources are viewed from a distance, as shown in Fig 4.1. When the angle θ between the light sources is large, they are seen as separate.

For
Examiner's
Use

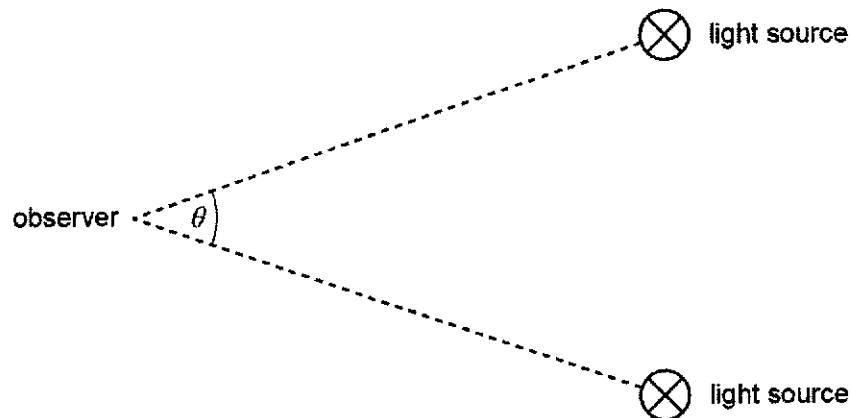

Fig. 4.1 (not to scale)

The sources are moved closer together. At a particular angle θ_1 the two sources appear as a single source.

The relation between θ_1 and the wavelength λ of the light from the sources may be written in the form of

$$\theta_1 = \frac{\lambda}{b}$$

where b is a constant.

It is inappropriate to measure θ_1 using a protractor as it is a small angle.

Design a laboratory experiment using two light sources to determine the value of b .

You should draw a diagram to show the arrangement of your apparatus and you should pay particular attention to

- the equipment you would use
- the procedure to be followed
- how the wavelength λ and angle θ_1 would be determined
- the control of variables
- any precautions that should be taken to improve the accuracy and safety of the experiment.

BLANK PAGE

BLANK PAGE

Anderson Serangoon Junior College 2019 H2 Physics Prelim Mark Scheme

Paper 1 (30 marks)

1	2	3	4	5	6	7	8	9	10
D	C	B	D	B	D	A	C	C	A
11	12	13	14	15	16	17	18	19	20
A	A	A	A	D	C	B	D	D	C
21	22	23	24	25	26	27	28	29	30
B	B	C	C	B	A	D	D	C	D

1	D	$x = \frac{\lambda D}{a}$ $\lambda = \frac{ax}{D}$ $\frac{\Delta \lambda}{\lambda} = \left(\frac{\Delta a}{a} + \frac{\Delta x}{x} + \frac{\Delta D}{D} \right) \times 100\%$ $= \left(\frac{0.02}{0.50} + \frac{0.1}{1.7} + \frac{0.002}{2.000} \right) \times 100\%$ $= 10\%$
2	C	Use $v^2 = u^2 + 2as$ $0 = u^2 + 2ax \Rightarrow u^2 = -2ax$ $0 = (1.20u)^2 + 2ax$ $1.44(-2ax)^2 = -2ax$ $x = 1.44x$
3	B	Ultimately, the vertical component of the ball will achieve terminal velocity when the force due to air resistance cancels out the weight of the ball.
4	D	P – contact force on box due to ground Q – gravitational force on box due to Earth R – contact force on ground due to box S – gravitational force on Earth due to box
5	B	Conservation of linear momentum : Total initial momentum = mv Total final momentum of Option A $= mv - mv = 0$ By velocity of approach and separation, KE not conserved for option A Total final momentum of Option B

974901/AS/RJC/2019PRELIM

Turn Over

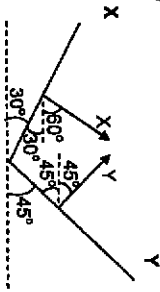
6	D	$= m(v + 0) = mv$ KE is conserved for option B. Total final momentum of Option C $= m \left(\frac{3v}{4} - \frac{v}{4} \right) = \frac{1}{2} mv$ By velocity of approach and separation, KE is conserved for option C Total final momentum of Option D $= m \left(\frac{v}{2} + \frac{v}{2} \right) = mv$ By velocity of approach and separation, KE not conserved for option D
7	A	 <p>consider horizontal equilibrium, $X_x = Y_y$ $X \cos 60^\circ = Y \cos 45^\circ$ $\frac{X}{Y} = 1.41$</p>
7	A	Since object is thrown at high speed, it experiences large upward viscous force, so resultant force upwards. This decelerates the ball, decreasing its speed and viscous force. Upthrust is dependent on the pressure difference acting on the object. As pressure difference remain the same as object falls, upthrust will remain unchanged.
8	C	When 3.0 N load is placed, $F = kx$, $3.0 = k(0.030)$, so $k = 100 \text{ Nm}^{-1}$ Using EPE = $\frac{1}{2} kx^2$ Additional EPE = $\frac{1}{2} k(x_{\text{total}}^2 - x_{\text{initial}}^2) = \frac{1}{2} (100)(0.040^2 - 0.030^2) = 0.035 \text{ J}$
9	C	Total gain in KE = loss in GPE of Y – loss of GPE of X – work done by friction $= (5.0)(9.81)(2.0) - (4.0)(9.81)(2.0 \sin 30) - 5(2)$ $= 48.86 \approx 49 \text{ J}$
10	A	Two forces, tension and weight, act on the pendulum. The resultant force should not be drawn. Hence, Options B and C are wrong. Pendulum moves along with the train in the circular arc, bending to the right. It must have a centripetal force (net force) directed to the right, towards the centre of the circular arc. Option A fulfils this requirement, the net force is directed to the right.

974901/AS/RJC/2019PRELIM

<p>11</p> <p>A</p> <p>Using $TE = \frac{GMm}{2r}$, $KE = \frac{GMm}{2r}$, we see that $KE = -TE$. Satellites with same KE has the same TE. Option A is correct.</p> <p>Using $KE = \frac{GMm}{2r}$, $GPE = -\frac{GMm}{r}$, we see that $KE = -\frac{1}{2}GPE$. Satellites with the same KE has the same GPE. Options B and C are wrong.</p> <p>Using $KE = \frac{GMm}{2r}$, we see that satellite A with larger mass must have a larger orbital radius than satellite B. Using T^2 proportional to r^3 and $\omega = 2\pi/T$, satellite A with larger r will have larger T, hence smaller ω. Option D is wrong.</p>
<p>12</p> <p>A</p> <p>$pV = NkT$ $p = (N/V)kT$ $p = N_A kT \quad (1)$ $0.50p = N'k(2.0T) \quad (2)$ $(2)/(1): N' = 0.25 N_A$</p>
<p>13</p> <p>A</p> <p>According to 1st law of thermodynamics, the internal energy of a system depends on the heat absorbed and the work done on the system. Thus, the internal energy of the system can also be changed without heating the system.</p> <p>For option B and C, it is only true if the system is an ideal gas.</p> <p>For option D, internal energy also depends on mass of the system. Two systems with same temperature but different masses will have different internal energies.</p>
<p>14</p> <p>A</p> $\frac{1}{2} m c_{rms}^2 = \frac{3}{2} kT$ $\Rightarrow c_{rms}^2 \propto T$ $\frac{T}{2T} = \frac{c_{rms}^2}{c_{new rms}^2}$ $c_{new rms} = \sqrt{2} c_{rms}$
<p>15</p> <p>D</p> <p>From v-x graph, v is negative \Rightarrow option C or D.</p> <p>The gradient of the v-t graph corresponds to the acceleration.</p> <p>Since $a = -\omega^2 x$, a and x are in opposite directions hence when x is negative, a is positive. Thus, the gradient of the v-t graph must be positive \Rightarrow options A or D.</p>

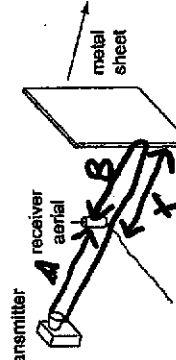
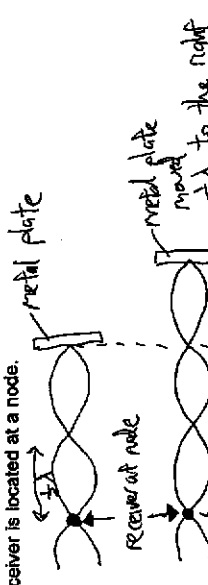
<p>16</p> <p>C</p> <p>Thus D meets both criteria.</p> <p>For a given velocity, by considering $v = f\lambda$, f is inversely proportional to λ.</p>
<p>17</p> <p>B</p> <p>Since $I \propto x_0^2$ and $I = \text{Power of source}/(\text{Area of focus})$ $I \propto x_0^2 / \text{Area}$ Since amplitude is doubled and area of focus is $1/3$ of original, the intensity (power per unit area) is 12 times of its original value.</p>
<p>18</p> <p>B</p> <p>Method 1:</p>  <p>At the receiver, the incoming wave (path A) meet the reflected wave (path B). The resultant displacement is the vector sum of individual displacement of the two waves. When path difference $l_B - l_A = 2x = (n + \frac{1}{2})\lambda$, the waves arrive in phase, leading to constructive interference, so detected voltage is maximum. This happens at distance moved = 30 mm, from graph provided.</p> <p>When metal sheet has moved another 60 mm (at distance moved = 90 mm), the voltage detected is maximum again, so it is another constructive interference, with path $l_B - l_A = 2(x + 60) = 2x + 120 = (n + \frac{1}{2})\lambda$.</p> <p>Hence, $\lambda = 120$ mm</p> <p>Method 2:</p> <p>The incoming wave from transmitter will undergo phase change of π rad upon reflection at the metal plate. The incoming and reflected waves will form a stationary wave, with a node at the metal plate.</p> <p>When distance moved = 0, a minimum voltage was detected, showing that the receiver is located at a node.</p>  <p>Receiver at node</p> <p>Metal plate moved $\frac{\lambda}{2}$ to the right</p>

19	<p>When metal plate moved by $\frac{1}{2}\lambda$ to the right, the stationary receiver will be at a node again, detecting a minimum voltage. This happens when distance moved = 60 mm.</p> <p>Hence, $\frac{1}{2}\lambda = 60$ mm, so $\lambda = 120$ mm</p> <p>D</p> <p>Contribution of E-field at the centre by a pair of like charges opposite each other will cancel out but by a pair of unlike charges, it will result in an E-field strength of 2 units pointing towards the electron.</p> <p>Hence, the net E-field for</p> <p>A is $2\sqrt{2}$ units, 225° (3rd quadrant);</p> <p>B is 2 units, 45° (1st quadrant);</p> <p>C is 2 units, 270°;</p> <p>D is less than 2 units, 112.5° (2nd quadrant).</p>
20	<p>C</p> $F_e = ma$ $a = \frac{F_e}{m} = \frac{qE}{m} = \frac{1.6 \times 10^{-19} \times 20000}{9.11 \times 10^{-31}} = 3.51 \times 10^{16} \text{ m s}^{-2}$ $s = at + 0.5at^2$ $s = 0.5(3.51 \times 10^{16})(4.0 \times 10^{-9})^2 = 0.0261 \text{ m}$ <p>B</p> $W = VQ = 18 \times 1.5 \times 0.2 = 5.4 \text{ J}$
22	<p>B</p> <p>Redraw the circuit diagram.</p> <p>6.0V</p> <p>Initially, resistance of T = R. Pd across each resistor = pd across T = 3V. Potential at B = Potential at E = 3V, so pd across BE = 0, so voltmeter reading = 0. When resistance of T = 2R,</p>

9749/01/AS/RJC/2019/PRELIM

Turn Over

23	<p>Potential at B is still 3V.</p> <p>Potential at E = $6 \times \frac{R}{2R + R} = 2 \text{ V}$.</p> <p>Potential across BE = $3 - 2 = 1 \text{ V}$, so voltmeter reading = 1V. Change in voltmeter reading = $1 - 0 = 1 \text{ V}$</p> <p>C</p> <p>The magnetic force acting on one vertical side = $BI\ell$, since the angle between B and I is 90°. The direction is obtained using FLHR.</p>
24	<p>C</p> <p>For straight conductor cutting magnetic flux, the induced emf $E = B\ell v$. Since the magnetic field and length of rod cutting the flux are both constant, E is proportional to the speed of the rod, which is the gradient of s-t graph.</p> <p>1st segment: constant gradient of s-t graph \Rightarrow const E</p> <p>2nd segment: decreasing gradient of s-t graph \Rightarrow decreasing E</p> <p>3rd segment: zero gradient of s-t graph \Rightarrow zero E</p>
25	<p>B</p> $I_{ms} = \frac{I_0}{\sqrt{2}} = \frac{2}{\sqrt{2}} = \sqrt{2} \text{ A}$ $I_{ac} = \sqrt{2} \text{ A}$
26	<p>A</p> <p>A: By using the relationship above, when the number of turns in the primary coil N_p is increased, the p.d. across the secondary coil V_s will decrease. $V_s/V_p = N_s/N_p$</p> <p>B: Increasing the cross sectional area does not affect the p.d. across the secondary coil.</p> <p>C: Increasing the resistance across the variable resistor only reduces the current in secondary coil (not the p.d. across it).</p> <p>D: Decreasing the resistance across variable resistor only increases the current in secondary coil (not the p.d. across it). $V_s/V_p = R_s/I_s$</p>
27	<p>D</p> $KE_{\text{electron}} = E_{\text{total electromagnetic photon}} = \frac{hc}{\lambda_{\text{min}}}$ <p>so, $\lambda_{\text{min}} = \frac{hc}{KE_{\text{electron}}} = \frac{hc}{qV}$</p>
28	<p>D</p> $p = p_x = m v_x = 9.11 \times 10^{-31} \times 2.05 \times 10^6 = 1.868 \times 10^{-24} \text{ kg m s}^{-1}$

9749/01/AS/RJC/2019/PRELIM

	$\Delta p / p = 0.5 / 100 \Rightarrow \Delta p = 9.34 \times 10^{27} \text{ kg m s}^{-1}$ $\Delta x \geq \frac{h}{\Delta p} = \frac{6.63 \times 10^{-34}}{9.34 \times 10^{27}} = 7.10 \times 10^{-6} \text{ m}$
29	<p>C</p> <p>Statement C is the result of conservation of linear momentum. The following statements are incorrect.</p> <p>Statement A – The stability of the nucleus depends on the binding energy per nucleon, not the binding energy.</p> <p>Statement B – The reaction can still occur provided energy is given to the reactants.</p> <p>Statement D – The half-life of a radioactive substance is a constant for a given radioactive substance.</p>
30	<p>D</p> <p>It is beta as the particles are able to penetrate through the thin film of aluminium where alpha particles will be stopped by the aluminium film.</p> <p>Entry is at B because the beta particles lose energy after passing through the aluminium. Hence, they have a lower speed and hence, a smaller radius, greater curvature of path under the influence of magnetic field. ($Bqv = \frac{mv^2}{r} \Rightarrow r = mv / Bq$)</p>

Anderson Serangoon Junior College 2019 H2 Physics Prelim Mark Scheme

Paper 2 (80 marks)

1a	Vertically upward arrow from point B representing upthrust and vertically downward arrow from point C representing weight of tube and sand. Both arrows are equal in length, representing equal magnitude.
1b	Upthrust for both cases are the same, equal to weight of tube and sand. Upthrust = weight of fluid displaced $\rho V A L g = \rho V A L g = \text{weight of tube and sand}$ $L = \rho V_{\text{tube}} / \rho A$ $= 0.99 \times 12.1 / 1.11$ $= 10.792 \text{ cm}$ Change in $L = 10.792 - 12.1$ $= -1.3 \text{ cm}$
1c i	Its weight and upthrust provide couple / restoring torque to keep tube upright.
1c ii	When the tube is displaced downward, the upthrust is greater than the tube's weight. Hence, the net force on the block is upward, opposite to the displacement. When the block is displaced upward, the block's weight is greater than the upthrust. Hence, the net force on the block is downward, opposite to the displacement.
2a	$g = GM/R^2$, so if distances near surface of planet is much smaller than R , g is a constant. force on rocket = mg , where m is mass of rocket, (g is the acceleration of free fall / gravitational field strength) $\Delta E_p = \text{force} \times \text{distance moved (or work done)}$ $= mgh$ OR $\Delta E_p = m \Delta \phi$ where m is mass of rocket $= GMm \left(\frac{1}{R} - \frac{1}{R+h} \right)$ $= GMmh / (R(R+h))$ distances h near surface of planet is much smaller than R , hence $(R+h) \approx R$ and $g = GM/R^2$ $\Delta E_p = mgh$
2b	Increase in GPE = Decrease in KE Increase in GPE = $G M m \left(\frac{1}{2R} - \frac{1}{5R} \right) = 4.0 \times 10^{24} \times 4.7 \times 10^4 \times \left(\frac{1}{2R} - \frac{1}{5R} \right)$ Decrease in KE = $(1.17 - 0.35) \times 10^{28} \text{ J}$ $3R = 2.0634 \times 10^7 = 2.1 \times 10^7 \text{ m}$
2c	Similarity: Gravitational fields are directed towards the planet and the rocket. Difference (any one): - Gravitational field at surface of planet is at orders of magnitude greater than that at the surface of the rocket. - Gravitational field at surface of planet has radial symmetry or is directed radially, but that at the surface of the rocket is not.

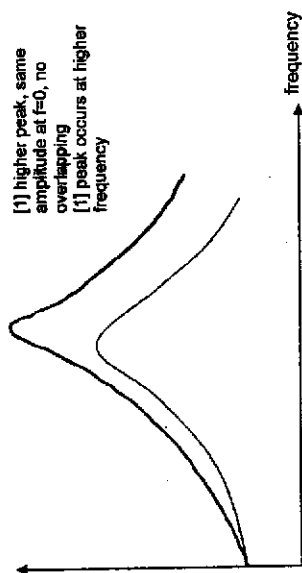
	<p>Magnitude of gravitational field at surface of planet is uniform, but that at the surface of the rocket varies.</p>
3a	<p>period = 0.36 s acceleration = $\omega^2 x_0$ $= (2\pi/0.36)^2 \times 1.7 \times 10^{-2}$ $= 5.2 \text{ m s}^{-2}$</p>
3b	<p>either kinetic energy = $\frac{1}{2} m\omega^2 (x_0^2 - x^2)$ or potential energy = $\frac{1}{2} m\omega^2 x^2$ and $\frac{1}{2} m\omega^2 (x_0^2 - x^2) = \frac{1}{2} \times \frac{1}{2} m\omega^2 x_0^2$ or $x_0^2 = 2x^2$ $x = x_0 / \sqrt{2} = 1.7 / \sqrt{2}$ $= 1.2 \text{ cm}$</p>
3c	 <p>[1] higher peak, same amplitude at $f=0$, no overlapping [1] peak occurs at higher frequency</p>

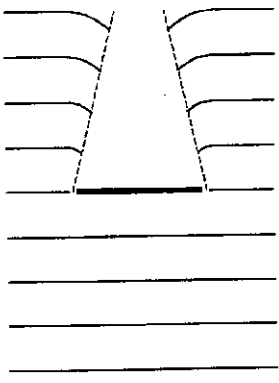
4ai	 <p>Diagram must show: (1) Wavefront curving into geometric shadow with some spreading (2) Wavelength unchanged</p> <p>(minus 1 mark if less than 4 wavelengths)</p>
4aii	<p>Angle of diffraction increases or More spreading of the wave.</p>
4bi	<p>$\sin \theta = \frac{\lambda}{b}$ $\sin \theta = (4.5 \times 10^{-7}) / (0.50 \times 10^{-3})$ Let width be c. $\tan \theta = 0.5 \text{ c} / 2.5$ $c = 4.500 \text{ mm} = 4.5 \text{ mm}$</p> <p>Accept small angle approximations.</p>
4bi1	<p>Coherent waves (from laser) diffracted from the slits will overlap and interfere.</p> <p>When waves meet (in phase) with phase difference of $2n\pi$ rad OR with path difference of $n\lambda$, where $n = 0, \pm 1, \pm 2, \dots$, constructive interference occurs and (maximum intensity is observed).</p> <p>And at the points where the waves (meet anti-phase) with phase difference of $(2n - 1)\pi$ rad OR with path difference of $(n + \frac{1}{2})\lambda$, destructive interference occurs and (minimum intensity) is observed.</p>
4bi2	<p>fringe separation, $x = \lambda D/a$ $= (4.5 \times 10^{-7} \times 2.5) / 1.25 \times 10^{-3}$ $= 9.00 \times 10^{-4} = 0.90 \text{ mm}$</p> <p>Number of bright fringes = $4.5 / 0.90$ $= 5$</p>

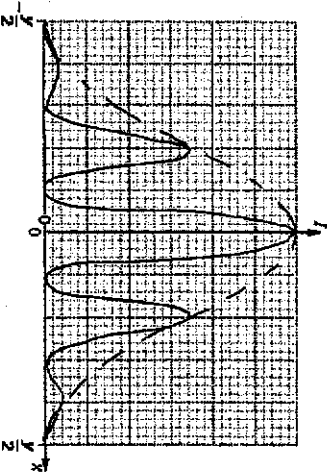
4b1i3	
5a	<p>Increasing current causes increasing magnetic flux (linkage) through the coil. (By Faraday's Law), increasing magnetic flux (linkage) induces e.m.f. in the coil. (By Lenz's Law), induced e.m.f. opposes the growth of current.</p> <p>Note: the induced e.m.f. will be opposite to the e.m.f. of the d.c. source. As a result, current increases at a slower rate.</p>
5b1	It is the product of the magnetic flux density and the area normal to the field through which the field is passing.
5b1i	<p>Magnetic flux density by solenoid $B = \mu_0 n I = 4\pi \times 10^{-7} \times (360 / 0.120) \times 2.5 \text{ A}$ $\text{flux } \phi = BA = B (\pi D^2/4) = B [\pi(0.088/2)^2/4]$ $= 5.808 \times 10^{-4} \text{ Wb}$ $= 5.8 \times 10^{-4} \text{ Wb}$</p>
5b1ii	<p>In the time given, $\Delta\phi = 2 \times 5.8 \times 10^{-4} \text{ Wb}$ Average e.m.f. $= N\Delta\phi/t = 96 \times 2 \times 5.8 \times 10^{-4} / 2.4 \times 10^{-3}$ $= 0.464 \text{ V} = 0.46 \text{ V}$</p>
5b1v	<p>Alternating / sinusoidal e.m.f. With same frequency as supply</p>
6a	<p>for a wave, electron can 'collect' energy continuously hence, electron will always be emitted / electron will be emitted at all frequencies after a sufficiently long delay</p>
6b1	<p>either wavelength is longer than threshold wavelength or frequency is below the threshold frequency or photon energy is less than work function</p>
6b1i	<p>$hc/\lambda = \phi + E_{\text{max}}$ $(6.63 \times 10^{-34} \times 3.00 \times 10^8) / (240 \times 10^{-9}) = \phi + 4.44 \times 10^{-19}$ $\phi = 3.8 \times 10^{-19} \text{ J (allow } 3.85 \times 10^{-19} \text{ J)}$</p>

974902/ASRJ/C2019/PELIM

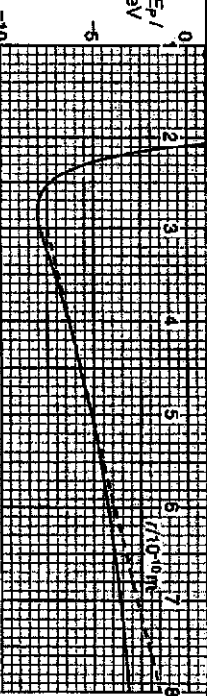

6c1	photon energy larger so (maximum) kinetic energy is larger
6c1i	fewer photons (per unit time) so (maximum) current is smaller
6d1	light is re-emitted in all directions / only part of the re-emitted light is in the direction of the beam
6d1i	an arrow between -3.40 eV and -1.51 eV and an arrow between -3.40 eV and -0.85 eV all arrows shown point 'upwards'
6d1ii	<p>$E = hc/\lambda$ or $E = hf$ and $c = f\lambda$ $2.80 \times 1.80 \times 10^{-18} = (6.63 \times 10^{-34} \times 3.00 \times 10^8) / \lambda$ $\lambda = 4.8 \times 10^{-7} \text{ m}$</p>
7a1	<p>Work is the product of a force and the distance moved in the direction of the force. $W = F \times \Delta r$</p> <p>Potential energy E_p is the work done (by external force) in moving a point charge from infinity to the point.) $(E_p = -F \times \Delta r)$</p> <p>Gradient of the graph $G = \frac{\Delta E_p}{\Delta r} = -F$ (accept if no negative sign) Hence the magnitude of $F = G$</p>
7a1i	For $r < 2.8 \times 10^{-10} \text{ m}$, the gradient is negative, hence the force is positive and thus repulsive force.
7a1ii	For $r > 2.8 \times 10^{-10} \text{ m}$, the gradient is positive, hence the force is negative and thus attractive force.
7a1ii1	At $2.8 \times 10^{-10} \text{ m}$, gradient is zero. $F = 0 \text{ N}$
7a1ii2	 <p>At $5.0 \times 10^{-10} \text{ m}$, $\text{Gradient} = \frac{[-1.5 - (-7.5)] \times 1.60 \times 10^{-19}}{(8-3) \times 10^{-10}}$ $F = 1.9 \times 10^{-9} \text{ N}$</p>

974902/ASRJ/C2019/PELIM

Turn Over

7d As the lattice is heated, its total energy increases.
 The total energy of the ions intersects the graph Fig. 7.3 at higher levels, giving rise to larger changes in potential energy during the oscillations.
 The ions will vibrate between greater values of separation r .

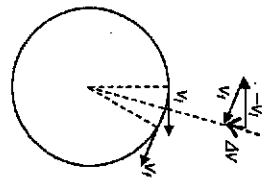
<p>7b</p> <ol style="list-style-type: none"> The force causes <u>repulsion</u> between the ions. (This is because the gradient of the graph of the equation $E = \frac{B}{r^n}$ is negative, hence, the force $F = -\frac{dE}{dr}$ is positive) The force is significant when the ions are very close to each other, and decreases rapidly as the distance increases. (As seen from the very steep gradient when the ions are close to each other). 	<p>7c</p> <ol style="list-style-type: none"> Horizontal line at -6 eV for total energy, labelled T. Reasonable curve starting and ending at zero, with a maximum point <p>Curve's maximum point is at $(2.75, 2.0)$, since potential energy is minimum at that point.</p> <p>By right, K line should be drawn such that at every point, $KE + PE = 6eV$.</p> <p>Minimum value of 2.35×10^{-10} m. Maximum value of 4.25×10^{-10} m</p>
<p>7ciii</p>	<p>F is not directly proportional to displacement r. OR the graph is not symmetrical Hence, not simple harmonic.</p>

<p>1a</p>  <p>Velocity v_1 represents the object's velocity at one instant and v_2 its velocity at a later instant.</p> <p>In the vector triangle, the change in velocity Δv ($=v_2 - v_1$), is due to a change in the velocity's direction, while the magnitude of v_1 and v_2 are the same.</p> <p>The direction of this change in velocity Δv is towards the centre of the circle, resulting in a centripetal acceleration perpendicular to velocity. Hence, the object is accelerating.</p> <ul style="list-style-type: none"> Vector diagram showing that velocity changes direction, with brief description. State that force or acceleration is perpendicular to velocity, and relate a change in direction of velocity to acceleration. 	<p>1bi</p> <ul style="list-style-type: none"> gravitational force by earth on man (vertically downwards) contact force by wall on man (diagonal to the left. Vertical component of contact force to be equal in magnitude to weight). <p>Accept: Contact force represented by Friction and Normal force, F</p> <p>Reaction in correct direction and magnitude</p> 
<p>1bii</p> <p>The upward frictional force is equal and opposite to the downward gravitational force acting on the rider. Hence, the rider would not fall off.</p> <p>The normal contact force by the wall on the rider provides for the centripetal force necessary for him to move together with the barrel in a circular path.</p>	<p>1biii</p> <p>acceleration $= r\omega^2 = r(2\pi)^2(33/60)^2$ $= 29.9 \text{ m s}^{-2}$</p>
<p>1biv</p> <p>Work done $= 0 \text{ J}$</p> <p>because the net force acting on the man (normal contact force) is always perpendicular to the velocity (or direction of motion) of the man at any instant. As the instantaneous velocity is in the same direction of instantaneous displacement, hence, work done which is the product of force and the displacement in the direction of the force would be zero.</p> <p>Or</p>	

<p>From the work-energy theorem, since there is no change in kinetic energy of the rider, there is no work done on the rider.</p>
<p>2a</p> <p>The Increase in Internal energy ΔU of a system is equal to the sum of the heat supplied Q to the system and the work done W on the system.</p>
<p>2bi</p> <p>Work done on gas $= -p(V_2 - V_1)$ $= -(1.04 \times 10^5)(4.0 \times 10^{-4} - 2.9 \times 10^{-4})$ $= -11.4 \text{ J}$ (1 mark if answer is not negative)</p>
<p>2bil</p> <p>$\Delta U = Q + W$ $= 28.5 + (-11.4)$ $= 17.1 \text{ J}$</p>
<p>2biii</p> <p>$\frac{V}{T} = \frac{V}{T}$ $T' = \frac{V}{V} = \frac{4.00 \times 10^{-4}}{2.9 \times 10^{-4}} = (314)$ $= 433\text{K}$</p>
<p>2biv</p> <p>$\frac{1}{2} m \langle c^2 \rangle = 3f2 \text{ kT}$ $\sqrt{\langle c^2 \rangle} = \sqrt{3kT/m}$</p> <p>Since k and m are constant, Ratio $= \sqrt{(T'/T)} = \sqrt{(433/314)} = 1.17$</p>
<p>3a</p> <p>A transverse wave is a wave in which the displacement of the particles in the wave are at right angles to the direction of transfer of energy of the wave.</p> <p>A longitudinal wave is a wave in which the displacement of the particles in the wave are along the direction of transfer of energy of the wave.</p>
<p>3bi</p> <p>$\Delta t = 0.78 - 1.5(0.50)$ $= 0.03 \text{ ms}$</p> <p>OR $\Delta t = 0.50 - (0.78 - 1.5(0.50))$ $= 0.47 \text{ ms}$</p> <p>Phase difference $= \Delta t / T \times 360^\circ$ $= 0.03/0.50 \times 360^\circ$ $= 21.6$ $= 22^\circ$</p> <p>OR</p> <p>Phase difference $= 0.47/0.50 \times 360^\circ$ $= 339^\circ$</p>

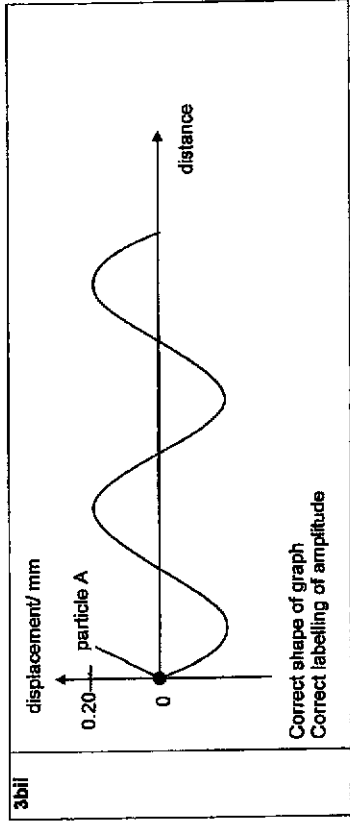

4a	Using $R = \frac{\rho l}{A}$ $= \frac{7.9 \times 10^{-7} (l)}{\pi (6.0 \times 10^{-3})^2}$ $l = 0.137 \text{ m}$
4bi	The resistance at a point on the curve can be determined using the ratio of voltage to the current at that point.
4bil	As V increases, temperature increases, the no. of charge carriers (positive holes and/or negative electrons) per unit volume increases. At the same time, the amplitude of vibration of atomic cores also increases, resulting in more frequent collisions with the atomic cores. The increase in conductivity due to more charge carriers is more significant than the decrease in conductivity due to increased thermal vibration. Hence resistance of thermistor decreases.
4bil 1.	$R_{XY} = \left(\frac{1}{960} + \frac{1}{1250} \right)^{-1} = 543\Omega$
4bil 2.	By Potential Divider Principle, $V_{XY} = \frac{R_{XY}}{R_{XY} + 7800} \times 1.5$ $= \frac{543}{543 + 7800} \times 1.5$ $= 0.0976 \text{ V}$
4bil 3.	When temperature drops, resistance of thermistor increases. Hence, the effective resistance of XY increases. By Potential Divider Principle, the potential difference across XY increases.

	Since power is proportional to V^2 for constant lamp resistance, the power dissipated in the filament lamp increases. Thus, the bulb is brighter.
5a	Zero electric field strengths in sphere A (between $x = 0$ and $x = 1.4$ cm) and in sphere B (between $x = 11.4$ and $x = 12.0$ cm)
5bi	Since the field strength is zero at a point between the spheres OR the electric fields are in opposite directions, the charges on the spheres are of the same sign.
5bil	At $x = 0.08$ m, the electric field strength due to sphere A cancels out the electric field strength due to sphere B. $E_A = E_B$ $\frac{Q_A}{4\pi\epsilon_0 (0.08)^2} = \frac{Q_B}{4\pi\epsilon_0 (0.04)^2}$ (substitution of distances required for credit of mark) $\frac{Q_A}{Q_B} = \left(\frac{0.08}{0.04} \right)^2 = 4$ Allow estimation from graph, $7.8 \text{ cm} < x < 8.2 \text{ cm}$
5bil	Diagram <ul style="list-style-type: none"> Correct field line direction (either all inwards or all outwards) and shape, and location of neutral point nearer to sphere B. More field lines radiating out of sphere A with closer spacing than sphere B, perpendicularly from the spheres E1: Incorrect number and spacing of field lines

9cl and ii	<p> ${}_{Z_p}^{A_p}P \rightarrow {}_{Z_x}^{A_x}X + {}_{-1}^0e$ By conservation of mass: $A_p = A_x + 0 \Rightarrow A_p - A_x = 0$ By conservation of charge: $Z_p = Z_x - 1 \Rightarrow Z_p - Z_x = -1$ </p> <p> ${}_{38}^{90}Sr + {}_2^4He \rightarrow {}_{Z_p}^{A_p}P + {}_0^1n$ By conservation of mass: $A_{Sr} + 4 = A_p + 1 \Rightarrow A_{Sr} - A_p = -3$ By conservation of charge: $Z_{Sr} + 2 = Z_p \Rightarrow Z_{Sr} - Z_p = -2$ </p>
9cii	<p>Total linear momentum of the system must be conserved throughout the process.</p> <p>Since initial total momentum of S and α is non-zero, final total momentum of them at closest approach must be non-zero.</p> <p>Hence, <u>not possible</u> for them to be at rest simultaneously.</p>

Name: _____ ()

Class: 19/ _____



ANDERSON SERANGOON JUNIOR COLLEGE

2019 JC2 Preliminary Examination

PHYSICS Higher 2

9749/04

Paper 4 Practical

Monday 2 September 2019

2 hours 30 minutes

Candidates answer on the Question Paper.
Additional Materials: As listed on the Confidential Instructions

READ THESE INSTRUCTIONS FIRST

Write your name, class index number and class in the spaces provided above.

Write in dark blue or black pen on both sides of the paper.
You may use an HB pencil for any diagrams, graphs or rough working.
Do not use staples, paper clips, glue or correction fluid.

Answer all questions.

Write your answers in the spaces provided on the question paper.

The use of an approved scientific calculator is expected, where appropriate.
You may lose mark if you do not show your working or if you do not use appropriate units.

Give details of the practical shift and laboratory where appropriate in the boxes provided.

At the end of the examination, fasten all your work securely together.

The number of marks is given in brackets [] at the end of each question or part question.

Shift
Laboratory

For Examiner's Use	
Paper 4 (55 marks)	
1	
2	
3	
4	
Total (55 marks)	

This document consists of 15 printed pages and 6 blank pages.

974904/ASRUC/2019/Prelim

Turn Over

1 In this experiment, you will investigate the motion of a sphere launched from a ramp.

- (a) Set up the apparatus as shown in Fig. 1.1. Adjust the height of the clamp so that the launch angle ϕ is approximately 15° . Do not bend the ramp throughout the experiment.

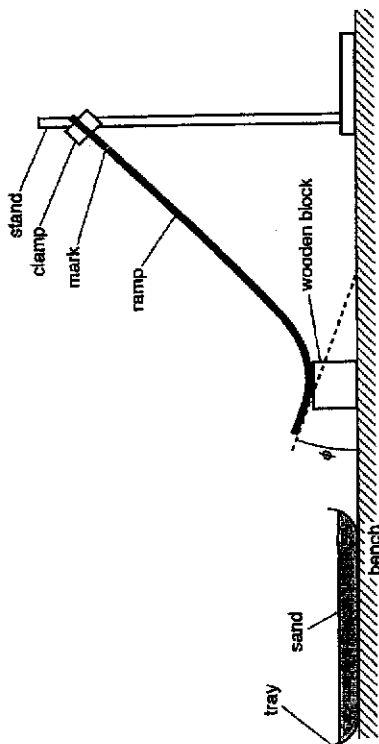

Fig. 1.1 (not to scale)

- (b) (i) Measure and record ϕ as shown in Fig. 1.1.

$\phi = 15^\circ$ [1]

- (ii) Measure and record the height h_1 of the mark above the bench, as shown in Fig. 1.2.

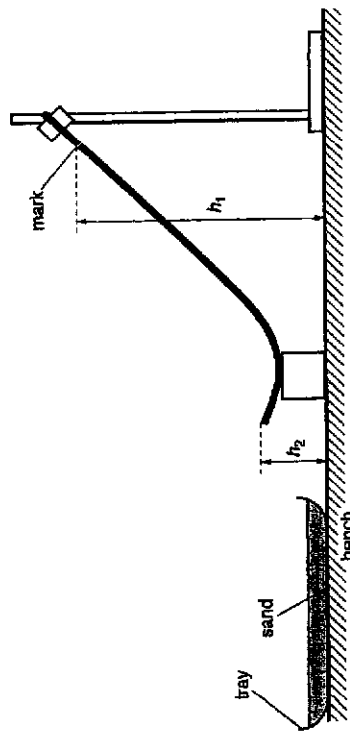

Fig. 1.2 (not to scale)

$h_1 = 0.280$ m [1]

--	--

- (iii) Measure and record the height h_2 of the end of the ramp, as shown in Fig. 1.2.

$h_2 = 0.085$ m [1]

- (iv) Calculate the speed v of the sphere when it leaves the ramp using the expression

$$v = \sqrt{2g(h_1 - h_2)}$$

where $g = 9.81 \text{ m s}^{-2}$.

$$v = \sqrt{2(9.81)(0.280 - 0.085)}$$

$$= 1.96 \text{ m s}^{-1}$$

$v = 1.96 \text{ m s}^{-1}$ [1]

- (c) Justify the number of significant figures you have given for your value of v .

Since, the number of s.f. for (h_1 ... h_2) is 3, hence v is 3 s.f. [1]

- (d) (i) Place the sphere on the ramp at the mark. Release the sphere.

- (ii) Measure and record the horizontal distance R from the end of the ramp to the landing position of the sphere, as shown in Fig. 1.3.

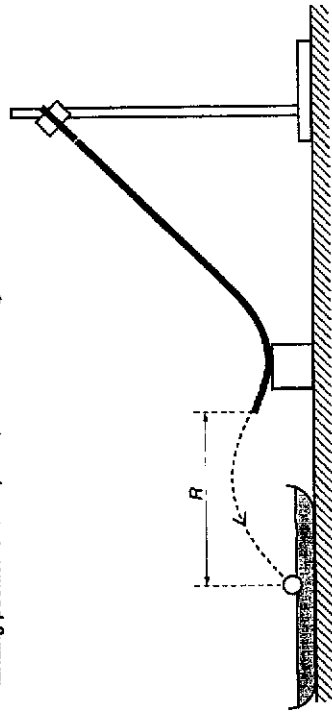

Fig. 1.3 (not to scale)

$$R = \frac{R_1 + R_2}{2}$$

$$= \frac{0.230 + 0.250}{2}$$

$$= 0.240 \text{ m}$$

$R = 0.240$ m [2]

(e) Estimate the percentage uncertainty in your value of R.

$$\text{percentage uncertainty} = \frac{0.005}{0.240} \times 100\% = 2.1\%$$

percentage uncertainty = 2.1% [1]

(f) By lowering the clamp, increase the launch angle ϕ to approximately 25°. Repeat (b) and (d) using the sphere.

$$v = \sqrt{2(9.81)(0.210 - 0.089)} = 1.54 \text{ m s}^{-1}$$

$$R = \frac{0.185 + 0.195}{2} = 0.190 \text{ m}$$

$$\phi = 25^\circ$$

$$h_1 = 0.210 \text{ m}$$

$$h_2 = 0.089 \text{ m}$$

$$v = 1.54 \text{ m s}^{-1}$$

$$R = 0.190 \text{ m} [2]$$

For Examiner's Use

A3	
----	--

M6	
M5	

(g) It is suggested that the relationship between R, v and ϕ is

$$R = k v \cos \phi$$

where k is a constant.

(i) Using your data, calculate two values of k.

$$k = \frac{R}{v \cos \phi}$$

first k

$$k = \frac{0.240}{1.96 \cos 15^\circ} = 0.126$$

second k

$$k = \frac{0.190}{1.54 \cos 25^\circ} = 0.136$$

$$\text{first value of } k = 0.126$$

$$\text{second value of } k = 0.136$$

[1]

(ii) Explain whether your results support the suggested relationship.

$$\text{Percentage difference in } k = \frac{\Delta k}{k} \times 100\% = \frac{0.136 - 0.126}{0.126} \times 100\% = 7.9\%$$

The criterion is percentage difference in k \leq percentage uncertainty in R.

Since the % difference in k value is more than the % uncertainty in R, the suggested relationship is not valid. [1]

M4	
----	--

(iii) It is not accurate to draw a conclusion based on only two readings as in g(i). Suggest a way the method can be changed.

Take 6 sets of readings by varying ϕ and plot a graph of R against $v \cos \phi$ to test the relationship. If the graph is a straight line passing through the origin, the relationship is valid. [1]

A5	
----	--

For Examiner's Use

For Examiner's Use

A6

A7

P1
P2
P3
P4

(h) (i) State one significant source of error in this experiment.
 It is difficult to measure R as the sphere rolls after landing / the landing mark is unclear. This will affect the accuracy of R .

 [1]

(ii) Suggest an improvement that could be made to the experiment to address the source of error identified in (h)(i). You may suggest the use of other apparatus or a different procedure.
 Use sticky surface (e.g. duct tape) to stop rolling/ dye on ball to mark paper/clay... to show landing mark so as to improve the accuracy of R .
 [1]

(i) A student is investigating the motion of a sphere launched horizontally from the ramp with a range of different speeds v .
 It is suggested that the square of the horizontal distance R from the end of the ramp to the landing position of the sphere is proportional to v .
 Explain how you would investigate this relationship using the same apparatus.

- Your account should include:
- your experimental procedure
 - control of variables
 - how you would use your results to test the relationship.

1. Decrease the launch angle ϕ to zero by raising the clamp.
 2. Fix the clamp position to keep ϕ constant throughout the experiment.
 3. Vary the speed v by releasing the sphere at different position on the ramp (or at different height h_2) to obtain 6 sets of readings of v and R .
 4. Plot a graph of R^2 against v . If the graph is a straight line passing through the origin, the relationship is valid.
-

 [4]

[Total: 18]

2 In this experiment, you will investigate the oscillatory motion of a loaded metre rule supported at one end by a spring.

(a) Secure the cork in the clamp so that the pin is mounted horizontally. Suspend one end of the rule from the pin by passing the pin through the hole in the rule. The rule should be able to pivot around the pin.

Hook one end of the spring to the rod of another clamp. Suspend the other end of the rule through the small loop of string. The string should be at the 0.5 cm marking of the rule as shown in Fig. 2.1.

The clamps should be adjusted so that the rule is approximately horizontal.

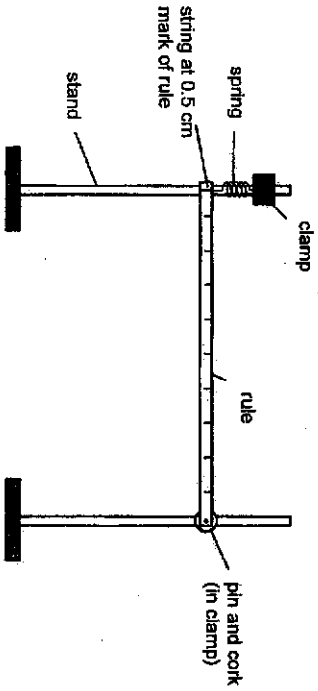

Fig. 2.1

(b) Tie a loop of string on the rule to suspend a mass of 350 g a distance d from the pin as shown in Fig. 2.2. The mass should be about halfway along the rule. Adjust the position of the clamps to make the rule approximately horizontal again.

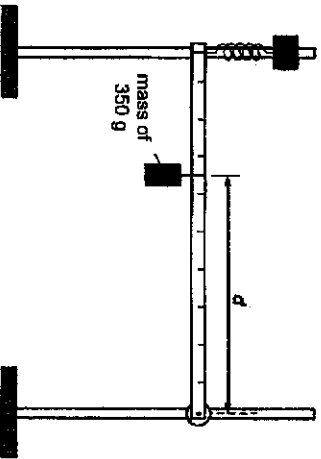

Fig. 2.2

974904/ASRJ/C2019/Prelim

(c) Measure and record the value of d .

$d = \dots 0.495 \text{ m} \dots$

(d) Gently displace the end of the rule so that it performs small oscillations in a vertical plane. Determine the period T of the oscillations.

$$T = \frac{t_1 + t_2}{2N} = \frac{14.5 + 15.1}{2(30)} = 0.493 \text{ s}$$

$T = \dots 0.493 \text{ s} \dots$ [2]

(e) The equation that relates T and d for this oscillator is

$$T^2 = \frac{4\pi^2}{kL^2} (Md^2 + C)$$

where k is 28.0 N m^{-1} , M is the mass of the load, L is the length of the rule and C is a constant.

Calculate C .

$$0.493^2 = \frac{4\pi^2}{(28.0)(1.000)^2} [(0.350)(0.495)^2 + C]$$

$$C = 0.0866 \text{ kg m}^2$$

$C = \dots 0.0866 \text{ kg m}^2 \dots$ [3]

[Total: 5]

M1	
M1	

M2	
M3	
M4	

974904/ASRJ/C2019/Prelim

Turn Over

3 In this experiment, you will investigate how the current through a milliammeter varies as the resistance of a resistor is changed.

(a) Set up the circuit as shown in Fig. 3.1.

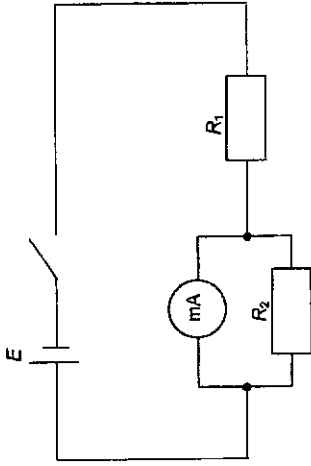

Fig. 3.1

Question 3 begins on the next page.

(b) The resistor of resistance R_2 can be made using any combination of the resistors provided. The resistance of each resistor is 100Ω .

(c) Set the value of R_2 to 100Ω and close the switch. Record the current I through the digital milliammeter.

$I = 3.88 \times 10^{-3} \dots \dots \dots \text{A}$ [1]

M1

- (d) Change the value of R_2 and repeat step (c) to obtain further sets of values for R_2 and the corresponding values of I .

R_2 / Ω	$I / 10^{-3} \text{ A}$	$\frac{1}{R_2} / 10^{-3} \Omega^{-1}$	$\frac{1}{I} / \text{A}^{-1}$
33.3	3.25	30.0	308
50.0	3.54	20.0	282
66.7	3.72	15.0	269
100	3.90	10.0	256
150	4.03	6.67	248
200	4.10	5.00	244
300	4.18	3.33	239

- (e) It is suggested that I and R_2 are related by the equation,

$$\frac{1}{I} = \frac{k}{R_2} + C$$

where k and C are constants.

Plot a suitable graph to determine values of k and C .

Plot a graph of $\frac{1}{I}$ against $\frac{1}{R_2}$ where k is the gradient and C is the y-intercept.

$$\text{gradient} = \frac{307.0 - 240.0}{(30.0 - 3.5) \times 10^{-3}} = 2530 = 2.53 \times 10^3$$

$$k = 2.53 \times 10^3 \text{ A}^{-1} \Omega$$

From graph y-intercept, $c = 231.5$
 $C = 232 \text{ A}^{-1}$ (allow 231.5 A^{-1})

Or
 Substitute $(30.0 \times 10^{-3}, 307.0)$ into $y = mx + c$,
 y-intercept, $c = 307.0 - (2530 \times 30.0 \times 10^{-3}) = 307.0 - 75.9$
 $C = 231.1 \text{ A}^{-1}$ (allow 231)

$$k = \dots 2530 \text{ A}^{-1} \Omega$$

$$C = \dots 232 \text{ A}^{-1}$$

[7]

For Examiner's Use

M0	
M1	
M2	
M3	
M4	
M5	

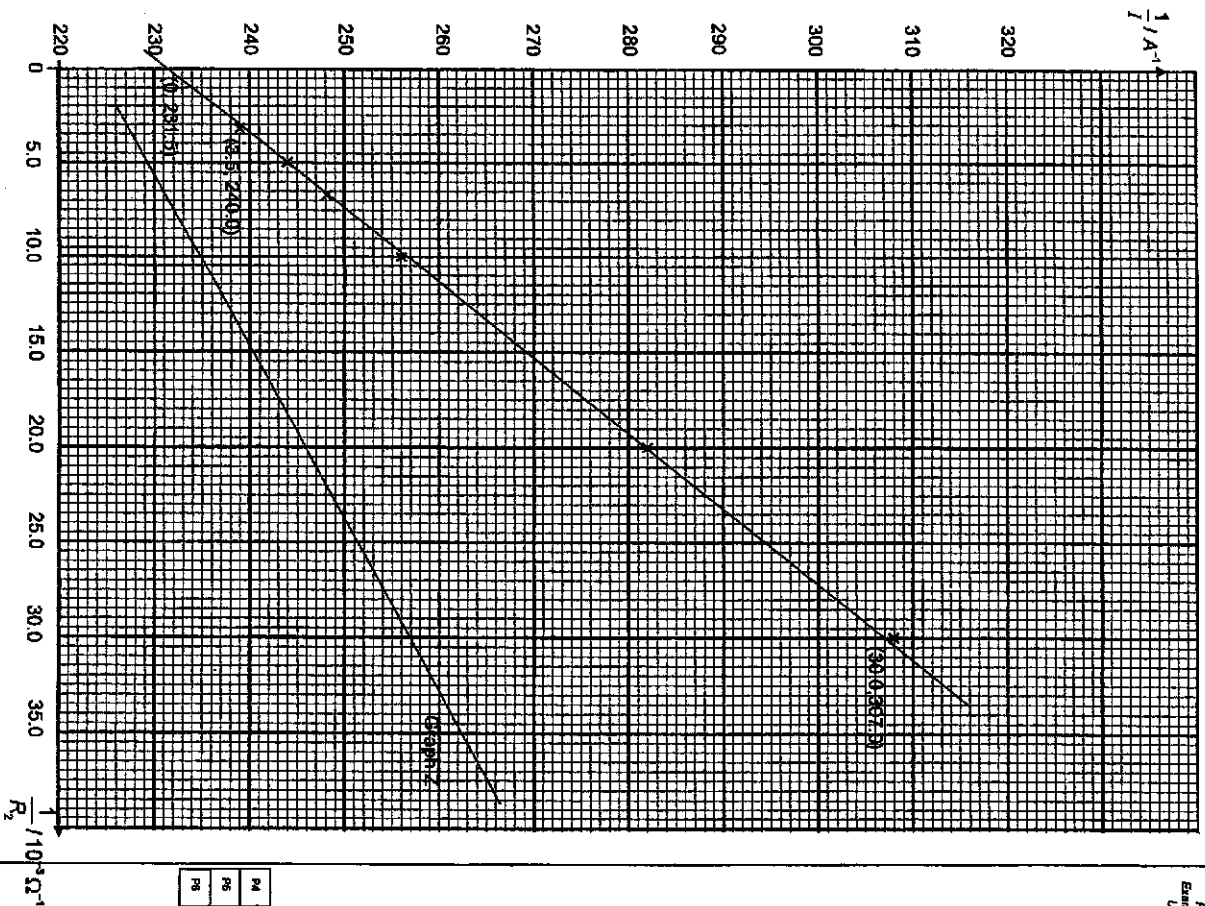

For Examiner's Use

M6	
M7	
M8	

For Examiner's Use

M

(f) (i) Comment on any anomalous data or results you may have obtained. Explain your answer.

There is no anomalous point as all the points are close to the best fit line. [1]

(ii) Measure and record a value of the e.m.f. E of the power supply using the analogue voltmeter.

$E = 2.15 \text{ V}$ [1]

M5

(g) Theory suggests that $k = \frac{RS}{E}$

where S is the resistance of the digital milliammeter.

Given that $R_1 = 470 \Omega$, together with your answers to (e) and (f)(ii), determine a value for S .

$$k = \frac{RS}{E}$$

$$S = \frac{kE}{R_1} = \frac{2530(2.15)}{470} = 11.6 \Omega$$

$S = 11.6 \Omega$ [1]

M6

(h) C is inversely proportional to E .

On the graph grid on page 13, sketch a second graph to represent the results if E is increased. Label this graph Z .

[2]

M7
M8

[Total: 20]

Question 4 begins on the next page.

4 Two identical light sources are viewed from a distance, as shown in Fig 4.1. When the angle θ between the light sources is large, they are seen as separate.

16

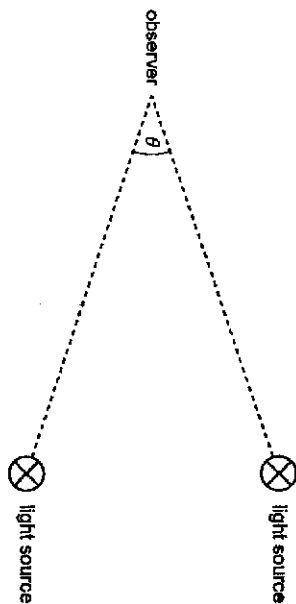

Fig. 4.1 (not to scale)

The sources are moved closer together. At a particular angle θ_1 the two sources appear as a single source.

The relation between θ_1 and the wavelength λ of the light from the sources may be written in the form of

$$\theta_1 = \frac{\lambda}{b}$$

where b is a constant.

It is inappropriate to measure θ_1 using a protractor as it is a small angle.

Design a laboratory experiment using two light sources to determine the value of b .

You should draw a diagram to show the arrangement of your apparatus and you should pay particular attention to

- (a) the equipment you would use
- (b) the procedure to be followed
- (c) how the wavelength λ and angle θ_1 would be determined
- (d) the control of variables
- (e) any precautions that should be taken to improve the accuracy and safety of the experiment.

9746904/ASRJJC2019/Prelim

For Examiner's Use

2019 ASRJJC2 Prelim H2 Physics P4 MS

17

Q1	Answer	Mark	Code
(b)(i) MIMO	Measurement of ϕ ϕ in range 10° to 20° , with unit and to nearest degree.	1	M1
(b)(ii) MIMO	Measurement of h_1 and h_2 Values of h_1 and h_2 to nearest mm.	1	M2
(b)(iv) ACE	Calculation of v Correct calculation of v with correct unit.	1	A1
(c) PDO	Calculated quantities (appropriate no. of significant figures) Justification based on number of significant figures in $(h_1 - h_2)$. Note: no credit if ans in b(i) not in 3.s.f.	1	P1
(d)(ii) MIMO	Measurement of R Value of R to nearest mm Evidence of repeat readings of R .	1 1	M3 M4
(e) ACE	Estimating uncertainties Percentage uncertainty in R calculated correctly to 2 s.f. using sensible value of ΔR (e.g. $2 \text{ mm} \leq \Delta R \leq 10 \text{ mm}$). Note: if $\Delta R = 10 \text{ mm}$, then R has to be recorded to 2 d.p. in metre for d(ii)	1	A2
(f) MIMO	Measurement of second values ϕ in range 20° to 30° . Second h_2 greater than first h_1 . Second h_1 less than first h_1 . Second R less than first R .	1 1	M5 M6
(g)(i) ACE	Calculation of k Two values of k calculated correctly with unit Note: k has to be recorded to 2 s.f. or 3 s.f.	1	A3
(g)(ii) ACE	Conclusion Valid conclusion relating to the calculated values of k , testing against a criterion	1	A4
(g)(iii) ACE	Modification Take 6 sets of readings and plot a graph of R against $v \cos \phi$. If the graph is a straight line passing through the origin, the relationship is valid.	1	A5
(h)(i) ACE	Sources of errors 1. It is difficult to measure R as the sphere rolls after landing / the landing mark is not clear/distinct. This will affect the accuracy of R . 2. It is difficult to measure R as the centre of sphere is determined by estimation. This will affect the accuracy of R . 3. It is difficult to measure ϕ as the ramp in contact with the block is curve/the alignment of the zero marking of protractor is uncertain. This will affect the accuracy of ϕ . 4. It is difficult to release marble from same position each time as alignment of the lowest point of the sphere on the mark is uncertain. This will affect the accuracy of h_1 .	1	Any 1 A6

9746904/ASRJJC2019/Prelim

Turn Over

Q3	Answer	Mark	Code
(d) MMO	Values of R_2 Correct values of R_2 (ie: 33.3, 50.0, 66.7, 100, 150, 200, 300)	1	M3
(d) PDO	Layout: Column headings (raw data & calculated quantities: R_2, I, $1/R_2$, $1/I$) Each column heading must contain an appropriate quantity and a unit. Ignore units in the body of the table. There must be some distinguishing mark between the quantity and the unit i.e. solidus is expected.	1	P1
(d) PDO	Table of results: raw data (appropriate degree of precision) All I values to nearest 0.01 mA.	1	P2
(d) PDO	Table of results: calculated quantities (appropriate no. of significant figures) For each calculated value of R_2 , $1/R_2$ and $1/I$, the number of s.f. should be the same or one more than the number of s.f. in the raw data. Note: No marks if $1/R_2$ and / or $1/I$ not present.	1	P3
(d) ACE	Table of results: calculated quantities Correctly calculated values of $1/R_2$ and $1/I$. Note: No marks if $1/R_2$ and / or $1/I$ not present.	1	A1
(e) ACE	Linearising Equation Linearising equation and deriving expressions that equate e.g. gradient to k and y-intercept to C .	1	A2
(e) PDO	Graph: Layout, choice of scale and labeling of axes Sensible scales must be used. Awkward scales (e.g. 3:10) are not allowed. Scales must be chosen so that the plotted points occupy at least half the graph grid in both x and y directions. Axes must be labelled with the quantity which is being plotted.	1	P4
(e) PDO	Graph: plotting of points All observations must be plotted. Check any 3 points and put ticks if correct. Work to an accuracy of half a small square.	1	P5
(e) PDO	Graph: trend line and ability to draw best fit line Straight line of best fit – judge by scatter of points about the student's line. There must be a fair scatter of points on either side of the line.	1	P6
(e) ACE	Interpretation of graph – gradient Gradient – the hypotenuse of the triangle must be greater than half the length of the drawn line. Read-offs must be accurate to half a small square. Check for $\Delta y/\Delta x$ (do not allow $\Delta x/\Delta y$). Note: Factor of 10^3 for calculation (ie: x values) or included in units for k .	1	A3
(e) ACE	Interpretation of graph – intercept y-intercept – must be read off to nearest half a small square or determined from $y = mx + c$ using a point on the line.	1	A4

Q1	Answer	Mark	Code
(h)(ii) ACE	Improvement 1. Use sticky surface (e.g. duct tape) to stop rolling/dye on ball to mark paper/ clay to show landing mark so as to improve accuracy of R . 2. Measure to edge of sphere and add half diameter (diameter of sphere can be measured using micrometer screw gauge) so as to improve accuracy of R . 3. Hold ruler as tangent so as to improve accuracy of ϕ . 4. Use a card as a stop on ramp to ensure marble is released from same position	1	A8
(i)	Planning 1. Decrease the launch angle ϕ to zero by raising the height of clamp. 2. Fix the clamp position to keep ϕ constant throughout the experiment. 3. Vary the speed v by releasing the sphere at different position on the ramp/different height h , to obtain 6 sets of readings v and R . 4. Plot a graph of R^2 against v . If the graph is a straight line passing through the origin, the relationship is valid.	1 1 1 1	PL1 PL2 PL3 PL4

Q2	Answer	Mark	Code
(c) MMO ACE	Calculation of T Evidence of repeated reading of raw time and NT more than 10.0 s. Correct calculation of T to 3 s.f. with units.	1 1	M1 A1
(d) ACE	Calculation of C Correct substitution of values (with correct units) into equation Correct calculation of C with correct range $0.0650 < C < 0.0860$ and sf. Correct units of C	1 1 1	A2 A3 A4

Q3	Answer	Mark	Code
(c) MMO	Measurement of I Value of I in the range $3.45 \times 10^{-3} \text{ A} \leq I \leq 4.05 \times 10^{-3} \text{ A}$, with precision to 0.01 mA	1	M1
(d) MMO	Set up apparatus from a circuit diagram and follow of written instructions <ul style="list-style-type: none"> Award 2 marks if the student has successfully collected 6 or more sets of data (R_s, I), without assistance/intervention. Award 1 mark if student has successfully collected 5 sets of data (R_s, I), without assistance/intervention. Award zero mark if student has successfully collected 4 or fewer sets of data (R_s, I), without assistance/intervention. Deduct 1 mark if student requires some assistance/intervention but has been able to do most of the work independently. Indicate the nature of any assistance. Deduct 2 marks if student has been unable to collect data without substantial assistance/intervention. Minimum mark for M2 = 0.	2	M2

Q3	Answer	Mark	Code
(e) ACE	Drawing conclusion Values of k and C calculated correctly with units.	1	A5
(f)(i) MMO	Identification of anomaly Anomalous data/results, if any, must be identified. Appropriate justification must be given. Otherwise, comment of absence of anomalous data. <i>Note: Can award if student correctly identified more than one anomalous point.</i>	1	M4
(f)(ii) MMO	Measurement of E E measured to the correct precision with unit. (Raw data last digit must be 0 or 5) <i>Note: Range of E must be between 1.80 V to 2.20 V</i>	1	M5
(g) ACE	Calculation of S S calculated with correct substitution of values (E from (f)(i) and k value from (e) and R_1). <i>Range of S between 5 Ω and 20 Ω</i>	1	A6
(h) ACE	Interpretation of graph – underlying principles When E increases, the gradient decrease and y-intercept decrease	1	A7

Suggested solution to Q4

Independent variable	Dependent variables	Control variables
What? λ of monochromatic light produced by LED	θ_1	Intensity of both LED lamps
How? Measure λ using Young's double slit expt Change type of LED to vary λ	s using metre rule, r using vernier callipers $\theta_1 = s/r$.	Fix power input to both lamps

Diagram

Side view

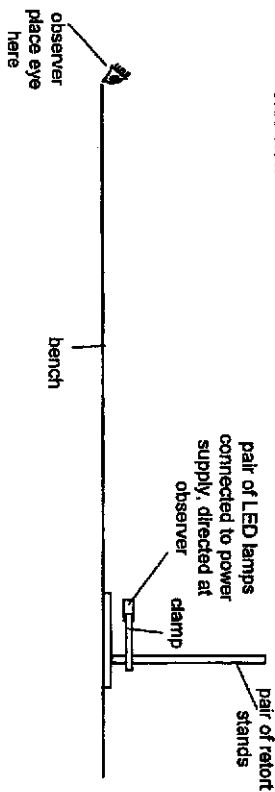

Top view



Procedure

1. Setup the experiment as shown in the diagram above with two identical monochromatic LED lamps.
2. With the observer looking at the lamps, gradually reduce the separation s between the lamps by bringing them closer together until the two sources appear as a single source to the observer.
3. Measure and record the distance r between the observer and one of the lamps using a metre rule.
4. Measure and record s using vernier callipers.
5. Calculate θ_1 using $\theta_1 = s/r$.
6. Using the Young's Double Slit Experiment, pass light from one LED lamp through a single slit, followed by a double slit, and allow fringes to form on a screen.
7. Calculate λ using $\lambda = ax/D$, where a is the slits separation, x is the fringe separation, D is the distance between the double slits and the screen.
8. Repeat experiment using different LED lamps of different colours to vary λ to obtain 6 sets of readings of λ and θ_1 .

Control of variables

1. Keep both light sources to be the same intensity by fixing the power input.

Analysis

1. Plot a graph of θ_1 against λ . The equation $\theta_1 = \frac{\lambda}{b}$ is valid if the graph is a straight line through the origin.
2. Determine the gradient of the graph. Calculate b using $b = 1/\text{gradient}$.

Safety and Accuracy

1. Take preliminary readings of λ , s and r to obtain measurable values of θ_1 .
2. Keep the observer equidistant to both light sources by measuring with rule and adjusting for every set of reading.
3. View with same eye to ensure consistency in resolving power of observer.
4. Light may damage eyes, therefore wear dark glasses when looking at the lamps. (refer to MS for other accepted answers)

Q4 Planning MS (12 marks)

Diagram	
D1	Labelled diagram showing observer, light sources with method of producing monochromatic light e.g. filter / coloured LED. Do not accept laser as light source as it may damage eyes. [1]
Procedure	
P1	Method to measure wavelength: quote either Young's double slit or diffraction grating equation with symbols defined. [1]
P2	Use a rule to measure r , r must be described or shown in diagram. [1]
P3	Method to determine θ , e.g. θ (or $\sin \theta$ or $\tan \theta$) = s/r or $\tan(\theta/2) = s/(2 \times r)$ r can either be distance between observer and one of the sources, or perpendicular distance between observer and centre of the two sources Do not allow protractor methods. [1]
P4	Repeat experiment by appropriate method (change filter or LED lamp of different colours/frequency/wavelength) to vary λ to obtain 6 sets of readings [1]
Control	
C1	Keep both light sources to be the same intensity by fixing the power input, OR Keep intensity of light sources constant throughout by fixing the power input. [1]
Analysis	
G1	Plot a graph of θ_1 against λ [1]
G2	$b = 1/\text{gradient}$ [1]
Additional detail and safety (3A + 1S)	
A1	Take preliminary readings of λ , distances r and separation s to obtain measurable values of θ_1 . [4]
A2	Use vertical lamps or slits to reduce the uncertainty in separation.
A3	Young's double slit method: pass light from source through a single slit, followed by a double slit, and allow fringes to form on a screen. Diffraction grating method: pass light from source through a diffraction grating, allow the bright spots to form on a screen.
A4	View with same eye to ensure consistency in resolving power of observer.
A5	Ensure the pair of light sources is in a plane perpendicular with the line of sight of observer by aligning the light sources using a set square. OR Keep the observer equidistant to both light sources by measuring with rule and adjusting after every set of reading.
A6	Repeat experiment for each λ and average readings to reduce the random error.
A7	Conduct experiment in a dark room to prevent other light sources from interfering and affecting the experiment.
A8	Use vernier caliper to measure s , as it is very small (for small angle θ_1), s must be described or shown in diagram.
S1	Do not allow vague vague computer methods. Lamp becomes hot, therefore do not touch/switch off when not in use or use gloves when moving hot lamp.
S2	Light may damage eyes, therefore wear dark glasses or do not look at unprotected lamps. (accept if light source is laser.)