



**VICTORIA JUNIOR COLLEGE**  
**2017 JC2 PRELIMINARY EXAMINATIONS**

---

**PHYSICS**

**8866/01**

**Higher 1**

**21 Sep 2017**

**Paper 1 Multiple Choice**

**THURSDAY**

**2 pm to 3 pm**

Additional Materials: Multiple Choice Answer Sheet

**1 Hour**

---

**READ THESE INSTRUCTIONS FIRST**

Write in soft pencil.

Do not use staples, paper clips, highlighters, glue or correction fluid.

Write your name, CT group and index number on the Multiple Choice Answer Sheet provided.

There are **thirty** questions on this paper. Answer **all** questions. For each question there are four possible answers A B C and D.

Choose the **one** you consider correct and record your choice in **soft pencil** on the separate Answer Sheet.

**Read the instructions on the Answer Sheet very carefully.**

Each correct answer will score one mark. A mark will not be deducted for a wrong answer.

Any working should be done in this booklet.

The use of an approved scientific calculator is expected, where appropriate.

---

This document consists of **16** printed pages.

## Data

speed of light in free space,	$c = 3.00 \times 10^8 \text{ m s}^{-1}$
elementary charge,	$e = 1.60 \times 10^{-19} \text{ C}$
the Planck constant,	$h = 6.63 \times 10^{-34} \text{ J s}$
unified atomic mass constant,	$u = 1.66 \times 10^{-27} \text{ kg}$
rest mass of electron,	$m_e = 9.11 \times 10^{-31} \text{ kg}$
rest mass of proton,	$m_p = 1.67 \times 10^{-27} \text{ kg}$
acceleration of free fall,	$g = 9.81 \text{ m s}^{-2}$

## Formulae

uniformly accelerated motion,	$s = ut + (\frac{1}{2}) at^2$ $v^2 = u^2 + 2as$
work done on/by a gas,	$W = p\Delta V$
hydrostatic pressure,	$p = \rho gh$
resistors in series,	$R = R_1 + R_2 + \dots$
resistors in parallel,	$1/R = 1/R_1 + 1/R_2 + \dots$

- 1 A car is initially travelling with a velocity of  $15 \text{ m s}^{-1}$  eastwards. At a later time, its velocity is  $15 \text{ m s}^{-1}$ ,  $60^\circ$  north of east. The change of velocity of the car is

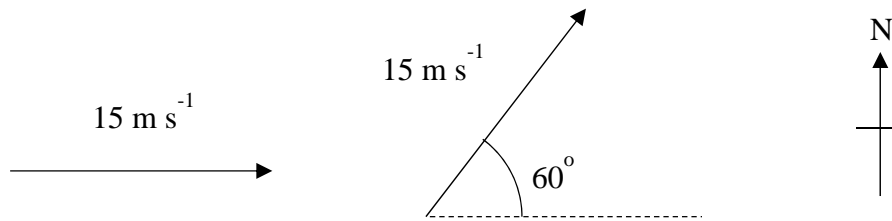

- A zero
- B  $26 \text{ m s}^{-1}$ ,  $30^\circ$  north of east
- C  $15 \text{ m s}^{-1}$ ,  $60^\circ$  north of west
- D  $13 \text{ m s}^{-1}$ , northwards
- 2 Express the *tesla* in base units.
- A  $\text{kg m s}^{-2} \text{ A}^{-1}$
- B  $\text{kg m}^2 \text{ s}^{-2} \text{ A}^{-1}$
- C  $\text{kg s}^{-2} \text{ A}^{-1}$
- D  $\text{kg m s}^{-2}$
- 3 The radius of a solid sphere is measured to be  $(7.50 \pm 0.03) \text{ cm}$  and its mass is measured to be  $(1.65 \pm 0.02) \text{ kg}$ . Determine the density of the sphere in  $\text{kg m}^{-3}$  and its associated uncertainty.

	<u>density / <math>\text{kg m}^{-3}</math></u>	<u>uncertainty / <math>\text{kg m}^{-3}</math></u>
A	$9.3 \times 10^{-4}$	$0.2 \times 10^{-4}$
B	933.71	0.02
C	934	2
D	930	20

- 4 The magnetic flux density at a point  $r$  from a straight, long wire carrying current  $I$  is given by  $B = \frac{\mu_0 I}{2\pi r}$  where  $\mu_0$  is a constant known as the permeability of free space.

Experiments were carried out to determine the magnetic flux density for different values of  $r$ . Which of the following graphs shows that the data collected are inaccurate but precise?

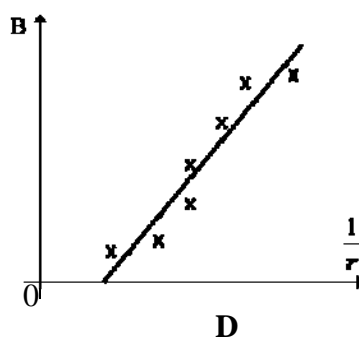
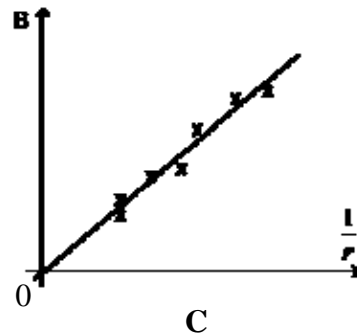
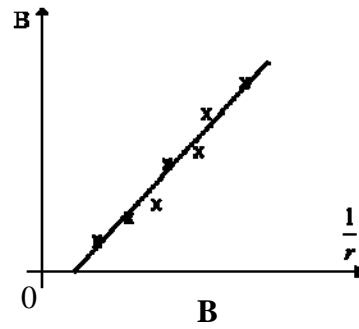
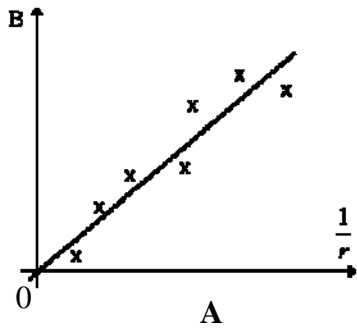

- 5 A brick falls vertically downwards from a tall building. Which of the following curves represents the variation with time  $t$  of its height  $h$  above the ground if air resistance is negligible?

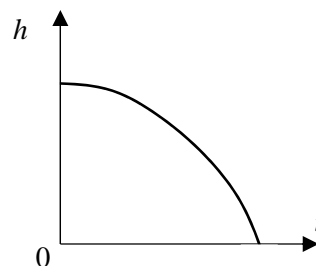
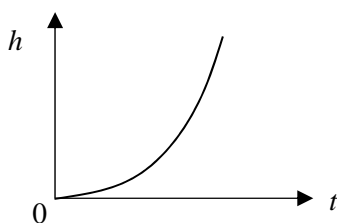
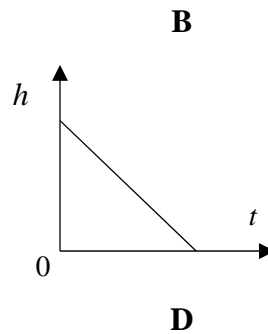
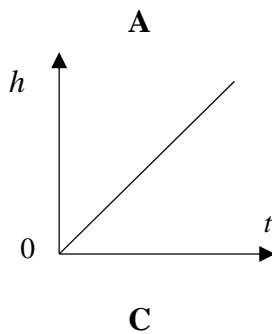

6 A body is thrown vertically upwards in a medium in which the drag force cannot be neglected. If the times of flight for the upward motion  $t_u$  and the downward motion  $t_d$  (to return to the same level) are compared, then

- A  $t_d > t_u$ .
- B  $t_d < t_u$ .
- C  $t_d = t_u$ .
- D it cannot be determined which will be larger.

7 An aquarium partly filled with water accelerates along a level surface as shown below. The water surface makes an angle  $\theta$  with respect to the horizontal. If the aquarium's acceleration is  $a$  while that due to gravity is  $g$ , deduce which of the following equations is correct. (Hint: consider forces acting on a single molecule at the water surface)

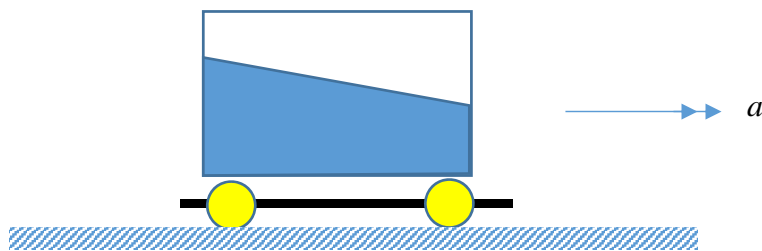

- A  $a = g \tan \theta$
- B  $a = g \sin \theta$
- C  $a = g \cos \theta$
- D  $a = g \cot \theta$

8 Two similar spheres, each of mass  $m$  and travelling with speed  $v$ , are moving towards each other.



The spheres have a head-on **elastic** collision. Which statement is correct?

- A The sum of the momenta before impact is  $2mv$ .
- B The kinetic energies before impact are zero.
- C The sum of the kinetic energies after impact is  $mv^2$ .
- D The spheres stick together on

- 9 A spring obeying Hooke's Law has an unstretched length of 50 mm and a spring constant of  $500 \text{ N m}^{-1}$ . What is the energy stored in the spring when its overall length is 70 mm?
- A 0.100 J                      B 0.600 J                      C 1.23 J                      D 100 kJ

- 10 Two forces  $P$  and  $Q$  act at a point  $X$  as shown in the vector diagram below.

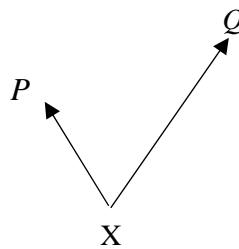

In which of the following diagrams does the vector  $F$  represent the force which must be applied at  $X$  to maintain equilibrium?

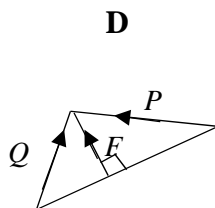
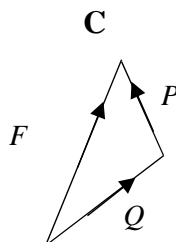
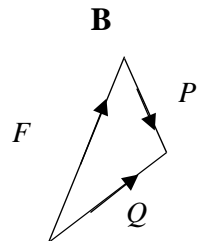
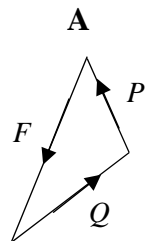

**11** The force diagrams show all the forces acting on a beam of length  $3x$ .

Which force system causes only rotational motion of the beam without any linear movement?

**A**

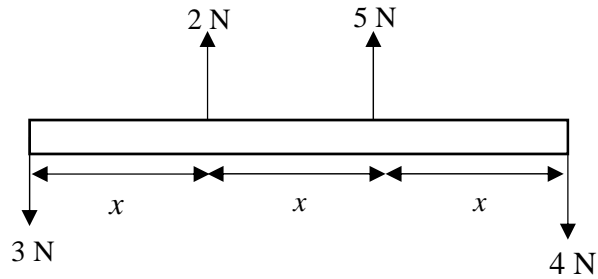

**B**

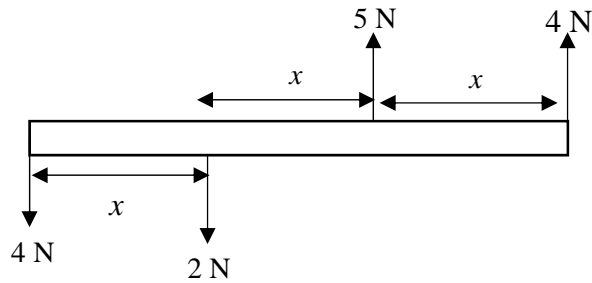

**C**

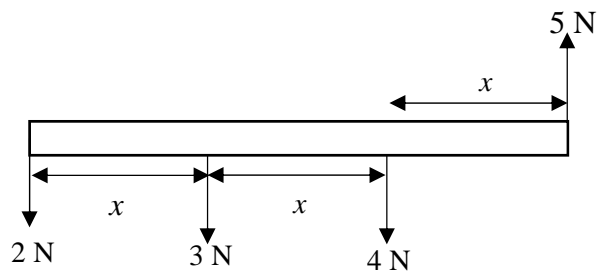

**D**

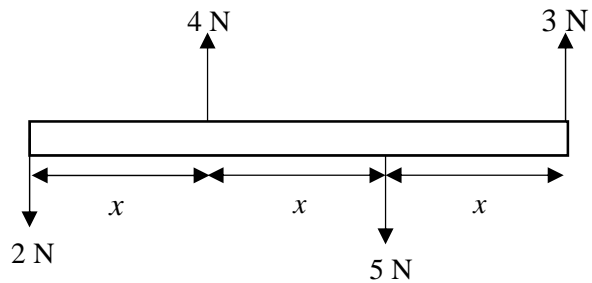

- 12 A soccer ball is kicked at an angle of  $60^\circ$  above the horizontal. Which graph shows how the kinetic energy  $E_k$  and the gravitational potential energy  $E_p$  of the ball vary from the time of impact until just before it reaches the ground? Ignore effects of air resistance.

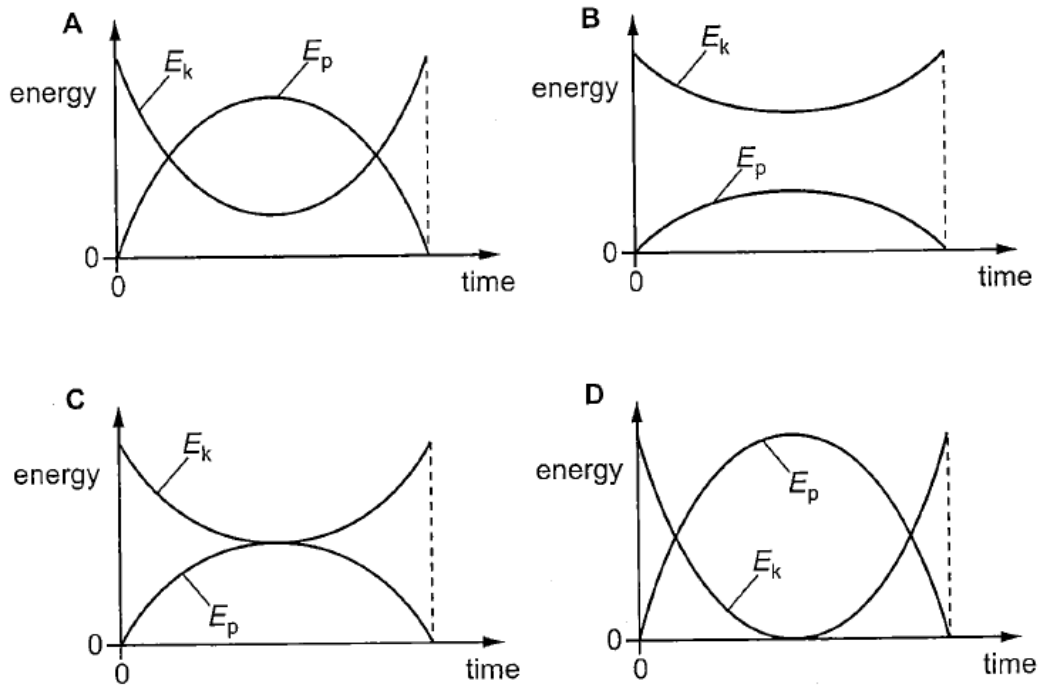

- 13 An object of mass  $m$  passes a point X with a velocity  $v$  and slides up a frictionless incline to stop at a point Y which is at a height  $h$  above X.

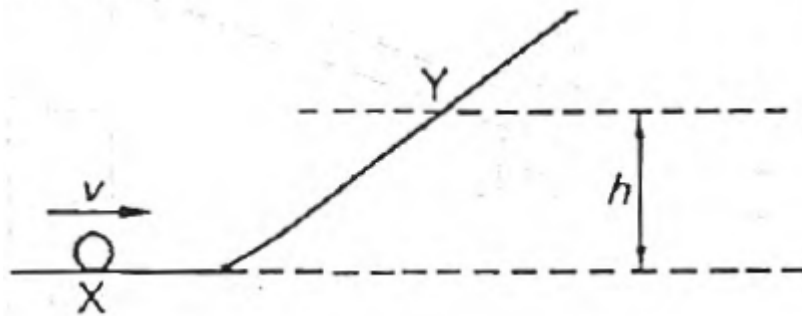

A second object of mass  $\frac{1}{2} m$  passes X with a velocity of  $\frac{1}{2} v$ . To what height will it rise?

- A  $h$
- B  $0.707 h$
- C  $\frac{1}{2} h$
- D  $\frac{1}{4} h$



- 14 A sound wave moves through air. The variation with time of the displacement of an air particle due to this wave is shown in the graph below.

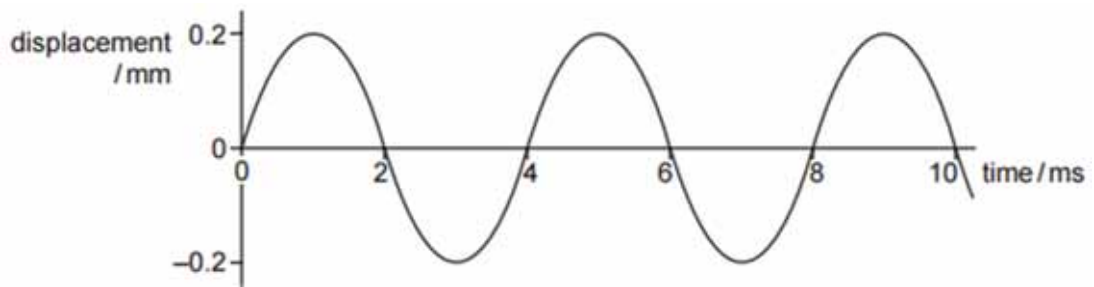

Which statement about the sound wave is correct?

- A The frequency of the wave is 500 Hz.
  - B The graph shows that sound is a transverse wave.
  - C The intensity of the wave will be doubled if its amplitude is increased to 0.4 mm.
  - D The wavelength of the sound wave is about 1.32 m.
- 15 A point source of sound emits waves equally in all directions. Which graph shows the variation with  $1/r$  of the amplitude  $A$  of the sound, where  $r$  is the distance from the source?

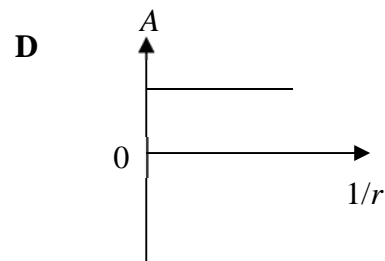
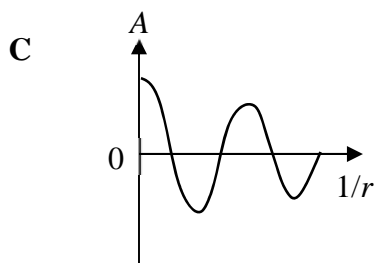
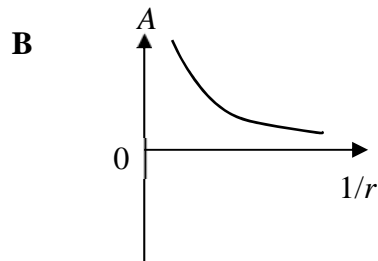
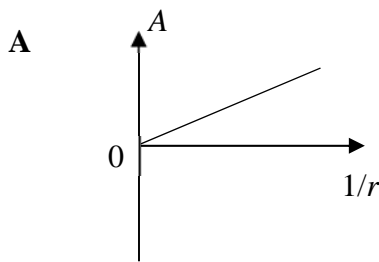

**16** If the wavelength of water waves is  $\lambda$ , which of the following slit widths gives the most diffraction?

- A**  $1.5\lambda$                       **B**  $3\lambda$                       **C**  $5\lambda$                       **D**  $10\lambda$

**17** Which of the following statements concerning standing waves below is **false**?

- A** They can be formed when microwaves of a fixed frequency from a source are directed at a reflector that reflects the waves back to the source.
- B** They have certain frequencies only when they are set up in a taut string fixed at its two ends.
- C** They can be formed when a loudspeaker generating sound at a fixed frequency is directed at a reflector that reflects the waves back to the source.
- D** They can be formed by tuning forks when they are placed in turn over a certain closed tube, regardless of their frequencies.

- 18 The diagram shows the relation between the current  $I$  in a certain conductor and the potential difference  $V$  across it.

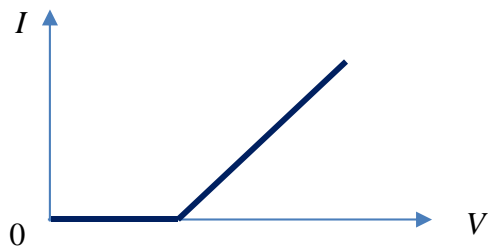

Which graph shows the correct relation between its resistance  $R$  and current  $I$ ?

**A**



**B**

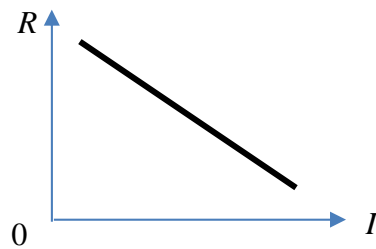

**C**

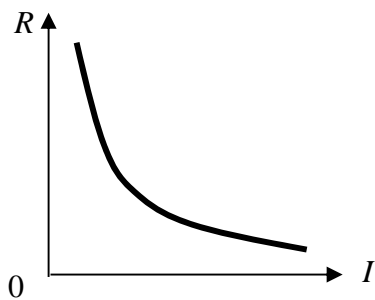

**D**

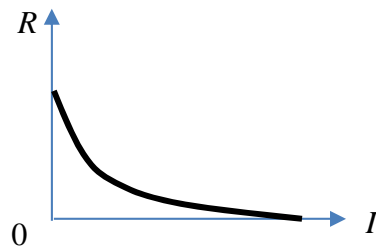

- 19 The graph below shows part of the  $I$ - $V$  characteristic of a resistor when a potential difference is applied across it from 0 to 2.0 V. The characteristic remains continuous and linear as shown by the short dotted line until the potential difference across it reaches 6.0 V. What is its resistance when a potential difference of 3.0 V is applied across it?

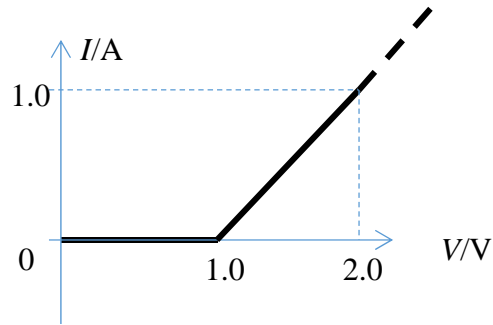

- A  $1.0 \Omega$                       B  $1.5 \Omega$                       C  $1.8 \Omega$                       D  $2.0 \Omega$
- 20 The diagram below shows five identical resistors each of resistance  $R$ . What is the total power dissipated by the resistors?

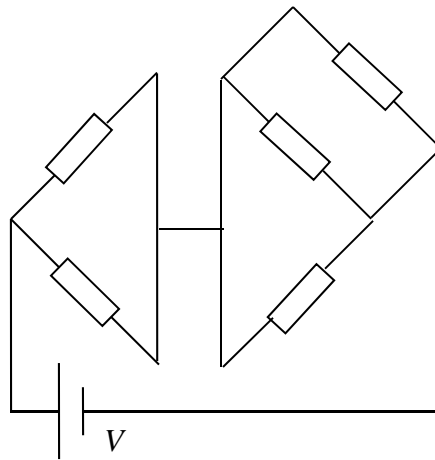

- A  $V^2/(2R)$                       B  $5V^2/(6R)$                       C  $V^2/R$                       D  $6V^2/(5R)$

21

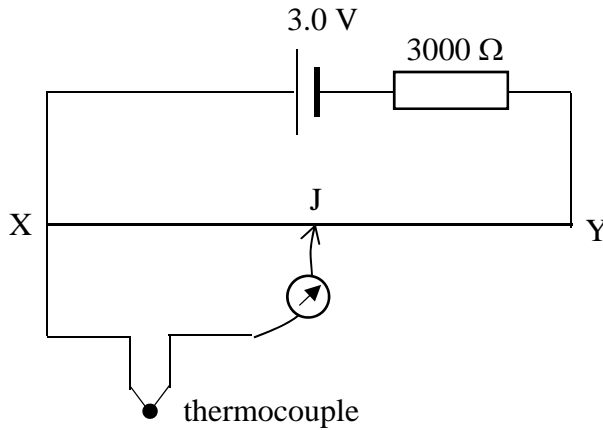

A thermocouple is connected across a potentiometer, and the jockey is slid along the metre bridge wire XY until balance point is reached. The balance length XJ is 80.1 cm. If the resistance of the bridge wire is  $2.00 \Omega$ , what is the e.m.f. of the thermocouple?

- A 0.82 mV      B 1.6 mV      C 2.2 mV      D 9.7 mV

22

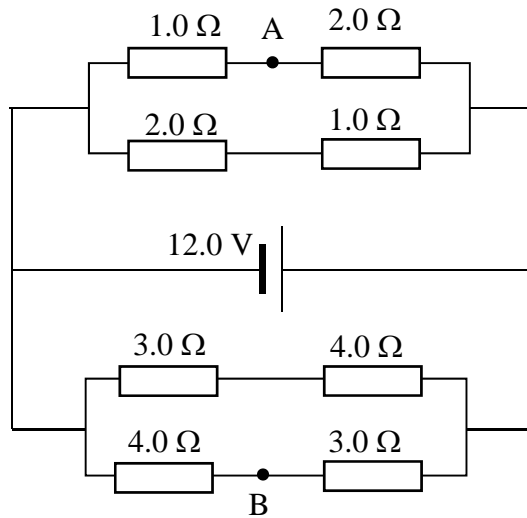

What is the p.d. between points A and B in this circuit?

- A 1.2 V      B 2.9 V      C 4.8 V      D 6.6 V

- 23 A linear conductor with current  $I_1$  is placed along the axis of a solenoid, which carries current  $I_2$ . The magnetic force acting on the conductor is:
- A zero;
  - B directly proportional to the product of currents  $I_1$  and  $I_2$ , and inversely proportional to the radius of the solenoid;
  - C directly proportional to the product of currents  $I_1$  and  $I_2$ , and inversely proportional to the square of the radius of the solenoid;
  - D directly proportional to the product of current  $I_1$ , current  $I_2$ , and the area of the solenoid

24

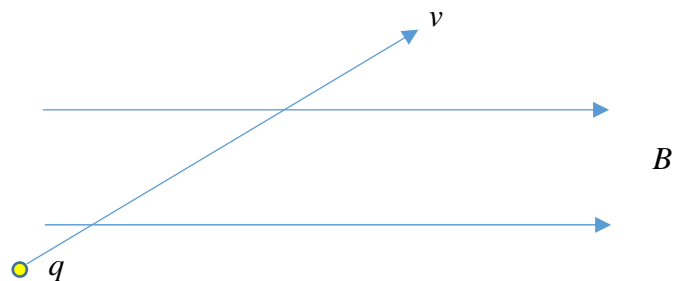

A positive ion of charge  $q$  is moving with a velocity  $v$  at an angle with respect to a uniform magnetic field of flux density  $B$  as shown in the figure. The ion experiences a magnetic force

- A directed out of the plane of the paper
- B directed into the plane of the paper
- C directed in the plane of the paper perpendicular to the magnetic field
- D directed in the plane of the paper parallel to the magnetic field

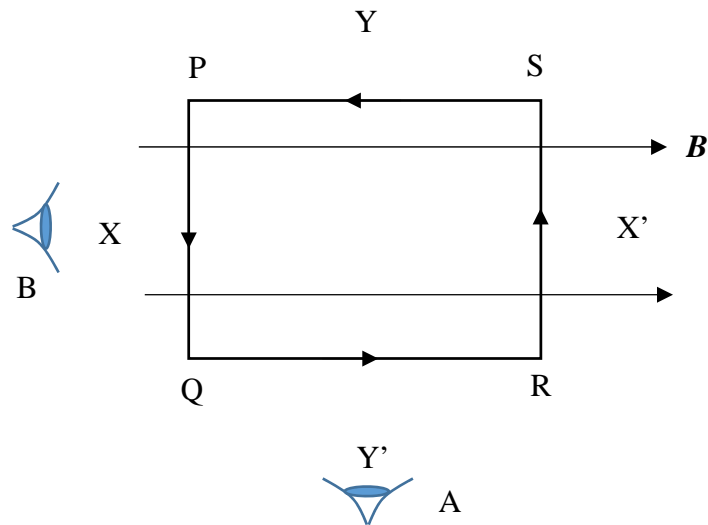

A rectangular coil carries a constant current that flows counter-clockwise in the coil. The coil is in the plane of the paper. A constant magnetic field is directed left to right in the plane of the coil. Which of the following is correct?

- A** When viewed from position A, the coil will rotate clockwise about axis  $YY'$
- B** When viewed from position A, the coil will rotate counter-clockwise about axis  $YY'$
- C** When viewed from position B, the coil will rotate clockwise about axis  $XX'$
- D** When viewed from position B, the coil will rotate counter-clockwise about axis  $XX'$
- 26** A photon of light enters a block of glass after travelling through a vacuum. The energy of the photon on entering the glass block
- A** increases because its associated wavelength decreases
- B** decreases because the speed of radiation decreases
- C** stays the same because the speed of the radiation and the associated wavelength increase by the same factor
- D** stays the same because the frequency of the radiation does not change

- 27 Photons of energy  $3.5 \times 10^{-19}$  J fall on the cathode of a photocell. The current through the cell is just reduced to zero by applying a stopping potential of 0.25 V. What is the work function energy of the cathode?

A  $2.9 \times 10^{-19}$  J      B  $3.1 \times 10^{-19}$  J      C  $3.5 \times 10^{-19}$  J      D  $3.9 \times 10^{-19}$  J

- 28 Which graph shows how the energy  $E$  of a photon of light is related to its wavelength  $\lambda$ ?

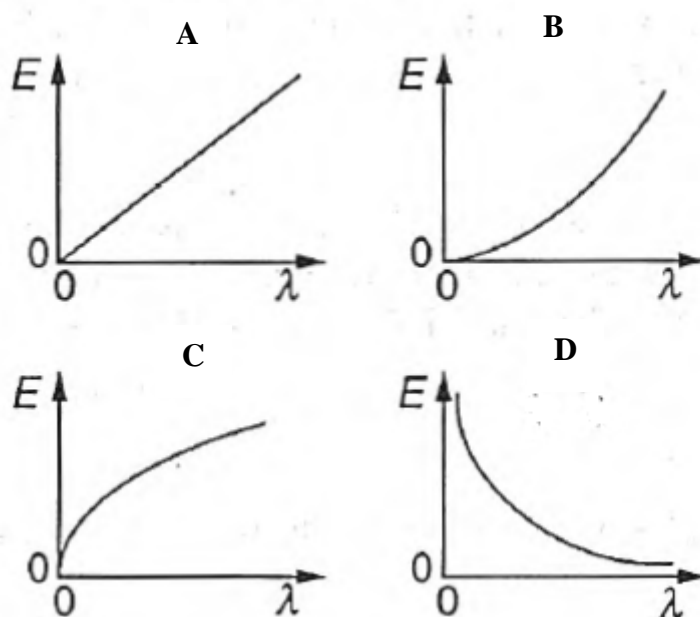

- 29 A hypothetical atom has three energy levels: the ground level and 2.00 eV and 3.00 eV above the ground level. A gas of these atoms was heated. Which of the following wavelengths of the emission spectral lines would not be detected?

A 414 nm      B 622 nm      C 1034 nm      D 1240 nm

- 30 What is the de Broglie wavelength of a particle of mass  $m$  and kinetic energy  $E$ ?

A  $h\sqrt{(2mE)}$       B  $\frac{\sqrt{(2mE)}}{h}$       C  $\frac{h}{\sqrt{(2mE)}}$       D  $\frac{h}{\sqrt{(mE)}}$

\*\*\*\*\* END \*\*\*\*\*



**VICTORIA JUNIOR COLLEGE**  
**SUGGESTED SOLUTIONS TO 2017**  
**PHYSICS PRELIM EXAMS 8866 P1**

1. Change in velocity

$$\Delta \vec{v} = \vec{v}_f - \vec{v}_i \text{ or } \vec{v}_f = \Delta \vec{v} + \vec{v}_i. \text{ Hence}$$

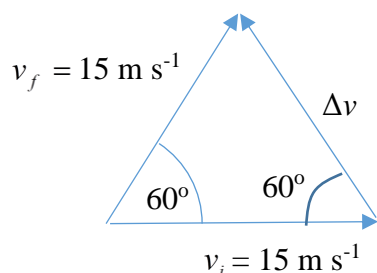

which shows an equilateral triangle, and  $\Delta v$  is  $15 \text{ m s}^{-1}$ ,  $60^\circ$  north of west

**Ans: C**

2. Consider a straight metallic rod of length  $L$  carrying a constant current  $I$  and placed in a magnetic field of flux density  $B$  perpendicular to the field. Then  $F = BIL$  or

$$B = \frac{F}{IL}. \text{ The SI unit for } B \text{ is the tesla (T).}$$

In base unit form, the tesla is equivalent to  $\frac{\text{kg m s}^{-2}}{\text{A m}} = \text{kg s}^{-2} \text{ A}^{-1}$

**Ans: C**

3. Density = mass/ volume

$$\rho = \frac{m}{\frac{4}{3}\pi r^3} = \frac{1.65}{\left(\frac{4}{3}\pi r^3\right)} = \frac{1.65}{\left(\frac{4}{3}\pi(0.075)^3\right)}$$

$$= 933.71 \text{ kg m}^{-3}.$$

$$\frac{\Delta \rho}{\rho} = \frac{\Delta m}{m} + 3 \frac{\Delta r}{r} = \frac{0.02}{1.65} + 3 \frac{0.03}{7.50} = 0.02412$$

$$\Delta \rho = 0.02412 \rho = 0.02412 \times 933.71 = 22.5 \approx 20 \text{ (1s.f.)}$$

$$\text{Hence } \rho = (930 \pm 20) \text{ kg m}^{-3}.$$

**Ans: D**

4. Graph B is inaccurate because the line does not pass through the origin. It is

precise because the points are close to the best fit line.

**Ans: B**

5.

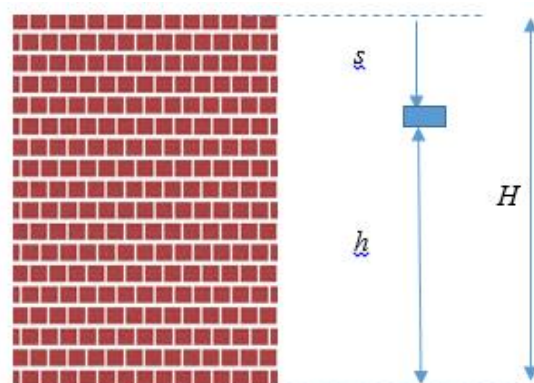

Using “ $s = ut + \frac{1}{2}at^2$ ”, we have

$$H - h = \frac{1}{2}gt^2 \text{ or } h = H - \frac{1}{2}gt^2$$

$h$  decreases as  $t$  increases, and gradient increases as  $t$  increases.

**Ans: D**

6.

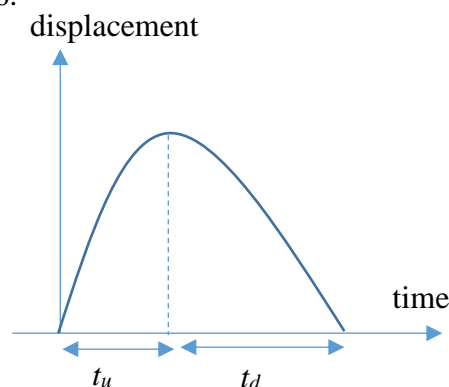

The displacement-time graph for the motion of the object is shown above. It can be seen that the time taken for the object to reach its highest point is shorter than that for it to return to its starting point.

**Ans: A**

7.

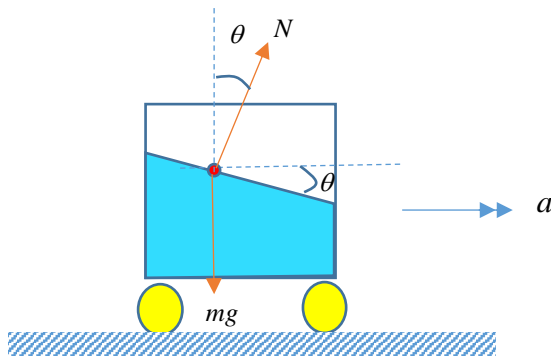

Forces acting on a molecule of mass  $m$  on the surface of the water are the weight  $mg$  and the normal reaction  $N$ .

For vertical equilibrium,  $N\cos\theta = mg \dots (1)$

For horizontal acceleration to the right,

$N\sin\theta = ma \dots (2)$

(2) gives  $\tan\theta = \frac{a}{g}$

**Ans: A**

8. An elastic collision corresponds to one where the total kinetic energy of colliding particles is conserved before and after the collision. Since the total KE before the collision is  $2 \times \frac{1}{2}mv^2 = mv^2$  before the collision, it will be  $mv^2$  after the collision.

**Ans: C**

9. Stored energy =  $\frac{1}{2}kx^2$   
 $= \frac{1}{2}(500)(0.020)^2 = 0.100 \text{ J}$

**Ans: A**

10. Three planar forces in equilibrium must form a closed triangle when the forces are joined head to tail relative to one another.

**Ans: A**

11. In option A, there are no translational and rotational equilibrium. In option B, there is no translational equilibrium and there is linear motion. Similarly, in option C, there is no

translational equilibrium and so there is linear motion. In option D, there is translational equilibrium but no rotational equilibrium (e.g. take moments about the left end of the beam). Hence the beam will not have linear motion but have only rotational motion.

**Ans: D**

12. When kicked at  $60^\circ$ , the soccer ball will still have a velocity at its highest point, hence D is not the answer. At the highest point, the velocity is

$v = v_0 \cos 60^\circ = \frac{v_0}{2}$ . Hence the final  $E_k$

must be  $E_k = \frac{1}{2}mv^2 = \frac{1}{2}\left(\frac{mv_0^2}{4}\right)$  which is

$\frac{1}{4}$  of the initial  $E_k$ . Hence answer is A.

**Ans: A**

13.

From conservation of energy,  
 loss of KE = gain in GPE

$\frac{1}{2}mv^2 = mgh,$

$h = \frac{v^2}{2g}$

When velocity is halved, the height reached will be a quarter of the original height reached.

**Ans: D**

14. Period  $T = 4 \text{ ms}$ ,  $f = 1/T = 250 \text{ Hz}$ ,  
 $v = f\lambda,$

Estimating the speed of sound in air to be  $330 \text{ m s}^{-1}$ ,  $330 = 250\lambda$

$\lambda = 1.32 \text{ m}.$

**Ans: D**

15.  $I = kA^2 = P/(4\pi^2),$  or  $A \propto 1/r$

**Ans: A**

16. When the size of the opening in a barrier is small compared to the wavelength of the wave, more diffraction occurs.

**Ans: A**

17. Only tuning forks of certain frequencies can cause resonance in the closed tube. Hence standing waves can only be formed at certain frequencies that match the natural frequency of the air column in the tube.

**Ans: D**

18. When the current is zero, it is equivalent to saying resistance is infinitely big.

An imaginary line drawn from the origin of the  $IV$  graph to the line where current increases with p.d.  $V$  shows the gradient of the imaginary line increasing progressively as  $V$  increases. But the gradient of the imaginary line is the inverse of resistance. Hence resistance decreases as p.d.  $V$  increases.

**Ans: C**

19. Using  $y = mx + c$ ,

or  $I = mV + c$ .

Take  $I = 1.0$  A, then  $V = 2.0$  V.

$m = 1$ ,  $c = -1$ , hence for the linear part  
 $I = V - 1$

When  $V = 3.0$  V,  $I = 2.0$  A,

$R = V/I = 1.5 \Omega$

**Ans: B**

20.

Redrawing the circuit,

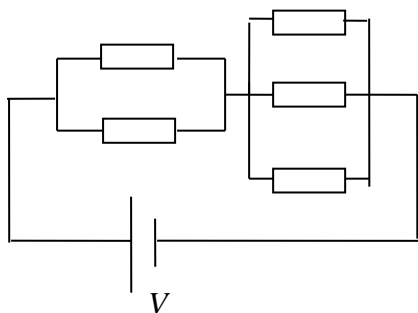

Effective resistance =  $R/2 + R/3$

$$= 5R/6$$

Power dissipated =  $6V^2/(5R)$

**Ans: D**

21. At balance point,

e.m.f. of thermocouple = p.d. across XJ

$$= \frac{R_{XJ}}{R_{XY} + 3000} \times E$$

$$= \frac{80.1}{100} \times 2.00$$

$$= \frac{2.00}{2.00 + 3000} \times 3.0$$

$$= 0.00160 \text{ V} = 1.60 \text{ mV}$$

**Ans: B**

22. P.d. across top  $1.0 \Omega$  resistor is

$$V_{OA} = \frac{1.0}{1.0+2.0} \times 12.0 = 4.0 \text{ V}$$

p.d. across bottom  $4.0 \Omega$  resistor is

$$V_{OB} = \frac{4.0}{4.0+3.0} \times 12.0 = 6.9 \text{ V}$$

$\therefore$  p.d. between A and B =  $6.9 - 4.0 = 2.9 \text{ V}$ .

**Ans: B**

23. The magnetic force acting on the conductor is zero because the magnetic field due to the current in the solenoid is either parallel or anti-parallel to the current in the linear conductor.

**Ans: A**

24.

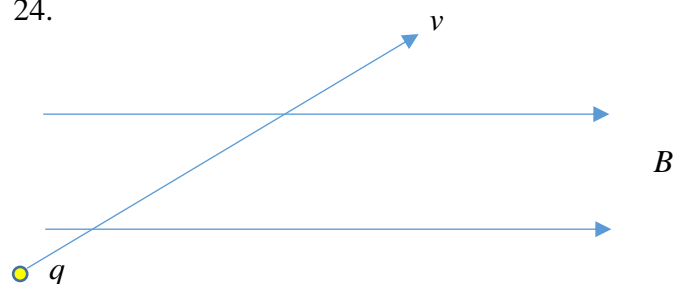

First, resolve  $v$  to obtain the component perpendicular to  $B$ .

By FLHR, this force is directed into the plane of the paper.

**Ans: B**

25.

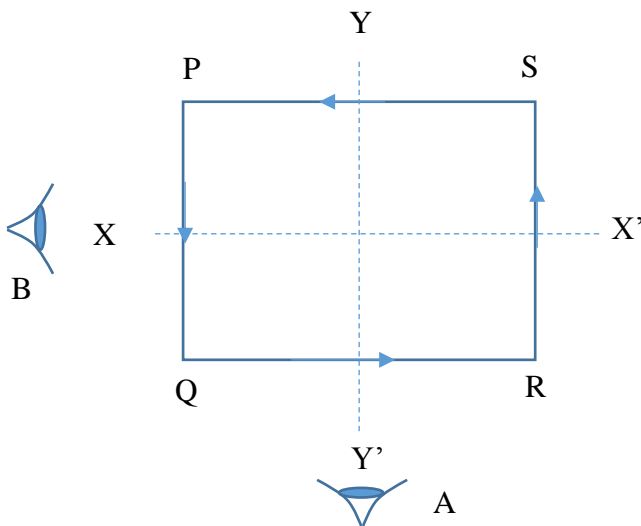

With the magnetic field directed left to right in the plane of the paper, arm PQ will experience a force up out of the plane of the paper. Arm RS will experience a force down into the plane of the paper. Arms SP and QR will not experience any force.

Looking from A, the coil will rotate clockwise about axis YY'.

**Ans: A**

26. Since  $E = hf$ , and since frequency stays the same within the glass block, the energy stays the same.

**Ans: D**

$$27. 0.25 \text{ eV} = 4.0 \times 10^{-20} \text{ J}$$

$$hf = \phi + eV$$

$$\phi = hf - eV = 3.5 \times 10^{-19} - 4.0 \times 10^{-20} \text{ J}$$

$$= 3.1 \times 10^{-19} \text{ J}$$

**Ans: B**

28. Since  $E = hc / \lambda$ , as  $\lambda$  gets bigger,  $E$  should become smaller.

**Ans: D**

29. Using  $\Delta E = hc / \lambda$ , and  $\lambda = hc / \Delta E$ , and substituting  $\Delta E$  of 1,2,3 eV, we find the corresponding  $\lambda$  to be

$$\lambda = hc / \Delta E = \frac{6.63 \times 10^{-34} \times 3 \times 10^8}{1 \times 1.6 \times 10^{-19}}$$

= 1240 nm (from 3.00 eV level to 2.00 eV level)

$$\lambda = hc / \Delta E = \frac{6.63 \times 10^{-34} \times 3 \times 10^8}{2 \times 1.6 \times 10^{-19}}$$

= 622 nm (from 2.00 eV level to ground)

$$\lambda = hc / \Delta E = \frac{6.63 \times 10^{-34} \times 3 \times 10^8}{3 \times 1.6 \times 10^{-19}}$$

= 414 nm (from 3.00 eV level to ground)

**Ans: C**

30. Using  $\lambda = \frac{h}{p}$  and since

$$E = \frac{p^2}{2m}, \quad p = \sqrt{2mE}$$

Combining the 2 equations, we have

$$\lambda = \frac{h}{\sqrt{2mE}}$$

**Ans: C**

\*\*\*\*\* END \*\*\*\*\*

Name : \_\_\_\_\_

CT group : \_\_\_\_\_



**VICTORIA JUNIOR COLLEGE**  
**2017 JC2 PRELIMINARY EXAMINATIONS**

**PHYSICS**

**8866/02**

**Higher 1**

**18 Sep 2017**

**Paper 2 Structured Questions**

**MONDAY**

**2 pm – 4 pm**

Candidates answer on the Question Paper

**2 Hours**

No Additional Materials are required.

**READ THESE INSTRUCTIONS FIRST**

Write your name and CT group at the top of this page.  
Write in dark blue or black pen on both sides of the paper.

You may use a soft pencil for any diagrams or graphs.  
Do not use staples, paper clips, highlighters, glue or correction fluid.

The use of an approved scientific calculator is expected, where appropriate.

**Section A**

Answer **all** questions.

**Section B**

Answer any **two** questions.

At the end of the examination, fasten all your work securely together.

The number of marks is given in brackets [ ] at the end of each question or part question.

For Examiner's Use	
<b>Section A</b>	
<b>1</b>	
<b>2</b>	
<b>3</b>	
<b>4</b>	
<b>5</b>	
<b>6</b>	
<b>Section B</b>	
<b>7</b>	
<b>8</b>	
<b>9</b>	
<b>Total (max. 80):</b>	

This document consists of a total of **21** printed pages.

## Data

speed of light in free space,	$c = 3.00 \times 10^8 \text{ m s}^{-1}$
elementary charge,	$e = 1.60 \times 10^{-19} \text{ C}$
the Planck constant,	$h = 6.63 \times 10^{-34} \text{ J s}$
unified atomic mass constant,	$u = 1.66 \times 10^{-27} \text{ kg}$
rest mass of electron,	$m_e = 9.11 \times 10^{-31} \text{ kg}$
rest mass of proton,	$m_p = 1.67 \times 10^{-27} \text{ kg}$
acceleration of free fall,	$g = 9.81 \text{ m s}^{-2}$

## Formulae

uniformly accelerated motion,	$s = ut + (\frac{1}{2}) at^2$ $v^2 = u^2 + 2as$
work done on/by a gas,	$W = p\Delta V$
hydrostatic pressure,	$p = \rho gh$
resistors in series,	$R = R_1 + R_2 + \dots$
resistors in parallel,	$1/R = 1/R_1 + 1/R_2 + \dots$

## Section A

Answer **all** the questions in this section.

- 1 A student throws a ball from point A to a friend at point B. The path of the ball is shown in **Fig. 1**.

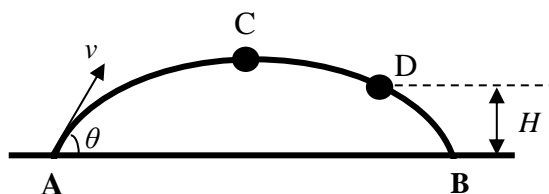

**Fig. 1**

The points A and B are on the same horizontal level. Air resistance is negligible.

- (a) The ball is thrown from A with velocity  $v$  at an angle  $\theta$  above the horizontal.

- (i) Express the speed,  $v_c$  of the ball at C, the highest point on its path of motion in terms of  $v$  and  $\theta$ .

[1]

- (ii) Point D is at height  $H$  above the horizontal AB. Express the speed,  $v_D$  of the ball at D, in terms of  $v$  and  $H$ . Show the steps clearly.

[2]

- (b) If air resistance cannot be neglected, sketch the path of the ball in **Fig. 1**.

[2]

- 2 A non-uniform bar XY makes an angle of  $60^\circ$  with a horizontal surface, as shown in Fig. 2.

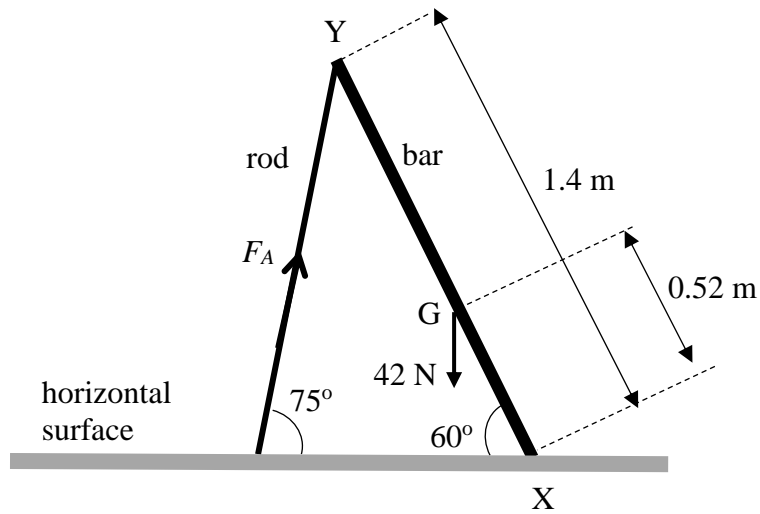

Fig. 2

The bar is hinged at X and is supported by a rod of negligible mass at Y. The force  $F_A$  produced by the rod at Y acts at an angle of  $75^\circ$  to the horizontal.

The bar has a length of  $1.4\text{ m}$  and a weight of  $42\text{ N}$ .

The centre of gravity G of the bar is  $0.52\text{ m}$  from X.

- (a) Use the Principle of Moments to find the magnitude of the force  $F_A$ .

Force  $F_A = \dots\dots\dots\text{ N}$  [2]

- (b) A force  $F_X$  acts on the bar at X.

- (i) Explain why a force is required to act on the bar at X to keep the bar in equilibrium.

.....  
 .....  
 .....  
 ..... [2]

- (ii) Draw an arrow to represent the force  $F_X$  in Fig. 2. [1]



**3** The Prius is a hybrid car that runs on both petrol and electricity. It has a mass of 1300 kg.

**(a)** Calculate the kinetic energy of a Prius that is moving at a speed of  $16.7 \text{ m s}^{-1}$ .

Kinetic energy = ..... J [1]

**(b)** The power  $P$  required to overcome external forces opposing the motion of the Prius is given by the expression,

$$P = 240v + 0.98v^3 .$$

**(i)** Calculate the magnitude of the external forces opposing the motion of the car when it is moving at a constant speed of  $16.7 \text{ m s}^{-1}$ .

Resistive force = ..... N [2]

**(ii)** Hence or otherwise, calculate the work done in overcoming the forces in **(b)(i)** during a time of 3.0 minutes.

Work done = ..... J [2]

4 (a)

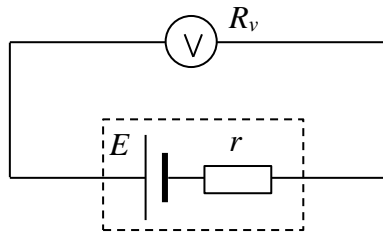

Fig. 4.1

A voltmeter is connected across the terminals of a cell of e.m.f.  $E = 2.0 \text{ V}$  and internal resistance  $r$  (see Fig. 4.1). If the resistance of the voltmeter is  $R_v$ , write down an expression for the voltmeter's reading. Express your answer in terms of  $R_v$ ,  $r$  and  $E$ .

[1]

(b) If  $r = 0.10 \Omega$ , determine the minimum resistance that the voltmeter must have for its reading to be within 0.1 % of the e.m.f.  $E$ .

Minimum resistance needed = .....  $\Omega$  [2]

(c)

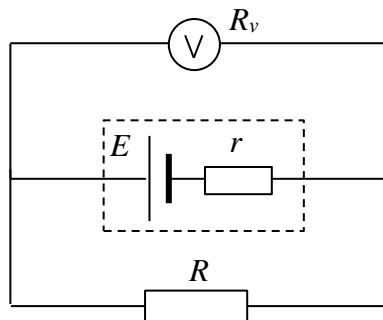

Fig. 4.2

The cell is now connected across a resistor  $R$  (see Fig. 4.2). Derive an expression for the reading of the voltmeter. Express your answer in terms of  $R_v$ ,  $r$ ,  $R$  and  $E$ .

[2]

**5** A metal wire  $L = 10$  m long lies east-west on a wooden table. The density  $D$  and resistivity  $\rho$  of the metal of the wire are  $1.0 \times 10^4 \text{ kg m}^{-3}$  and  $2.0 \times 10^{-8} \Omega \text{ m}$  respectively. The wire has a radius of cross-section  $0.457$  mm. The horizontal component of the earth's magnetic field  $B$  is  $1.8 \times 10^{-5} \text{ T}$ . A p.d. is applied to the ends of the wire.

(a) Draw a diagram to show the directions of current, magnetic field and magnetic force acting on the wire.

[1]

(b) Calculate the resistance of the wire.

Resistance = .....  $\Omega$  [2]

(c) Determine the minimum potential difference that would have to be applied to the ends of the wire in order to make the wire rise from the surface of the table.

Minimum p.d. = ..... V [2]

6



**Fig. 6.1**

Two spheres approach each other along a line joining their centres, as illustrated in **Fig. 6.1**.

When they collide, the forces acting on spheres A and B are  $F_A$  and  $F_B$  respectively. The forces act for time  $t_A$  on sphere A and time  $t_B$  on sphere B.

(a) State the relationship between

(i)  $F_A$  and  $F_B$ , taking into consideration their directions. For the sign convention, take the rightward direction as positive.

..... [1]

(ii)  $t_A$  and  $t_B$ .

..... [1]

(b) Use your answers in (a) to show that the change in momentum of sphere A is equal in magnitude and *opposite in direction* to the change in momentum of sphere B.

[2]

- (c) For the spheres in (b), the variation with time of the momentum of sphere A before, during and after the collision with sphere B is shown in **Fig. 6.2**. The momentum of sphere B before the collision is also shown in **Fig. 6.2**.

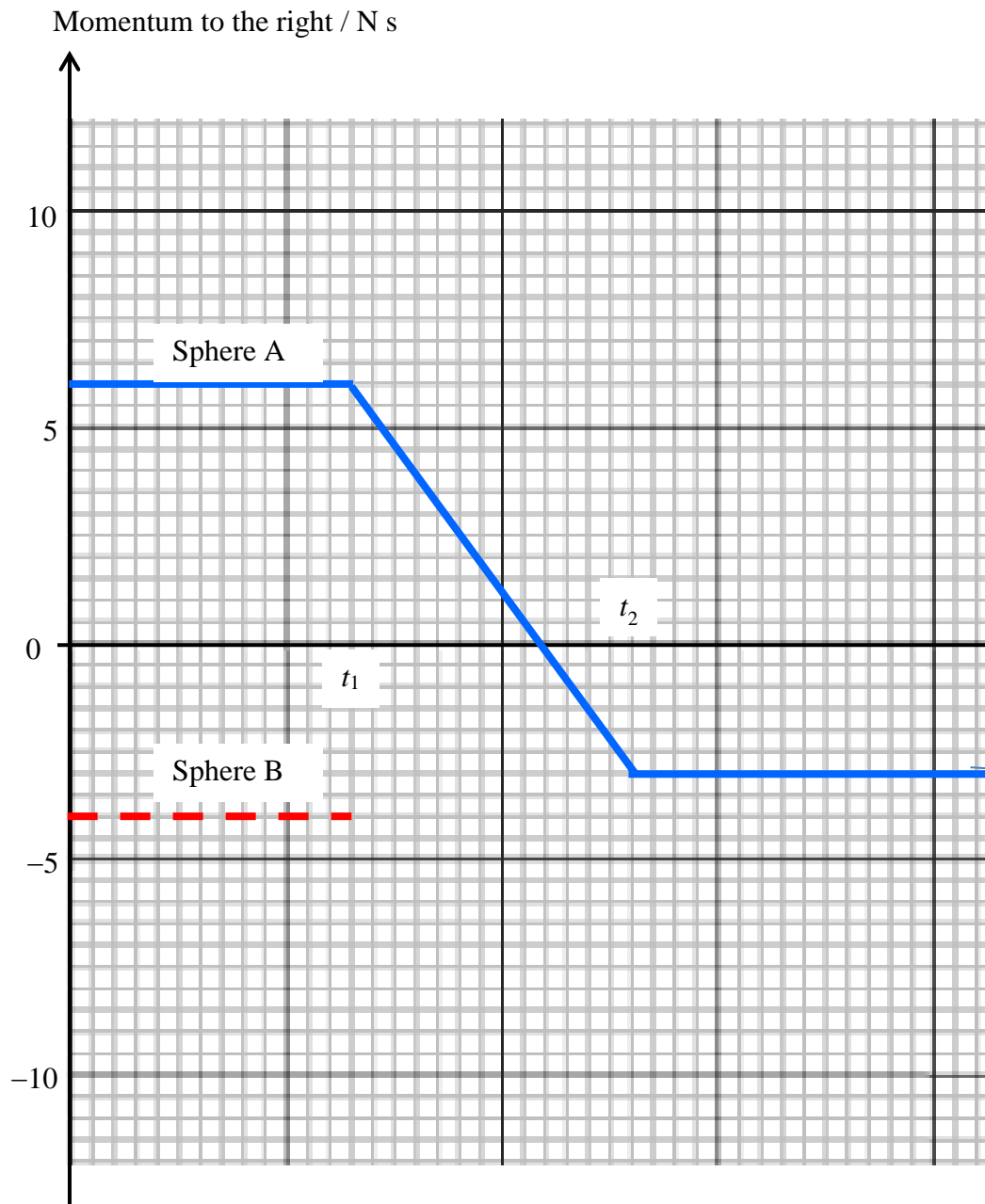

**Fig. 6.2**

- (i) Using the result from (b), calculate the momentum of sphere B after its collision with sphere A.

Momentum = ..... kg m s<sup>-1</sup> [2]

- (ii) Complete **Fig. 6.2** to show the variation with time of the momentum of sphere B during and after the collision with sphere A. [2]

- (d) The initial velocity  $u_A$  is 3.0 m s<sup>-1</sup>. Calculate the mass of sphere A and its final velocity  $v_A$ .

Mass = ..... kg [1]

$v_A$  = ..... m s<sup>-1</sup> [1]

- (e) Calculate the ratio of the final to initial velocities  $\frac{v_B}{u_B}$  of sphere B.

$$\frac{v_B}{u_B} = \dots\dots\dots [2]$$

- (f) The mass of sphere B is 1.0 kg. Determine quantitatively whether the collision is elastic or inelastic.

[3]

### Section B

Answer **two** of the questions from this section.

- 7 (a) Bob has a mass of 71 kg. He stands on a spring scale in an elevator. The spring balance reads in newtons. Starting from rest, the elevator ascends with constant acceleration, attaining its maximum speed of  $1.2 \text{ m s}^{-1}$  in 0.80 s. It travels with this constant speed for the next 2.0 seconds. The elevator then undergoes a uniform deceleration for 1.9 s and comes to rest.

- (i) Draw a labelled velocity-time graph for Bob's motion.

[2]

- (ii) Draw a corresponding labelled graph to show how the readings of the spring balance varies with time for the whole of Bob's motion. Show your calculations.

[4]

- (b) Bob steps into the elevator to go to the ground floor. For some reason, the elevator malfunctions and plunges suddenly.

- (i) Explain, using Newton's Laws, why (apart from fear) Bob feels lighter while the elevator is plunging towards the ground floor.

.....  
.....  
.....  
.....  
..... [2]



- (ii) Bob reasons that if the elevator cables had been cut, he would effectively be weightless. Explain using Newton's Laws.

.....  
 .....  
 ..... [2]

(c)

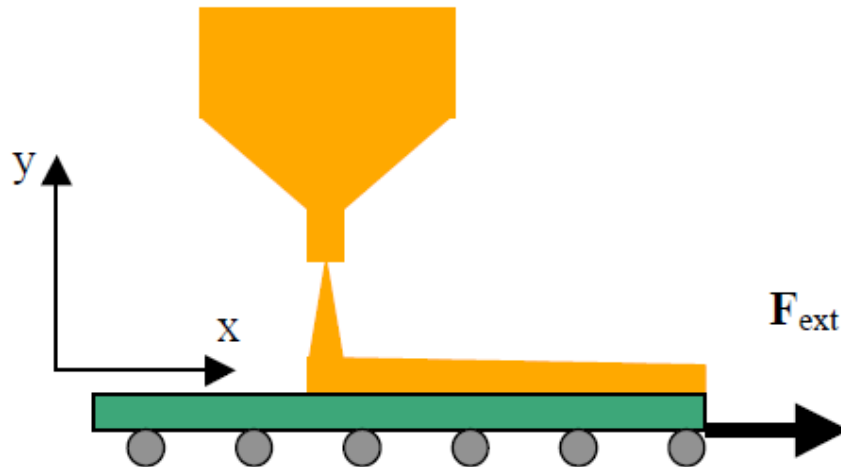

Sand from a stationary hopper falls onto a moving conveyor belt at a rate of  $5.00 \text{ kg s}^{-1}$  as shown above. The conveyor belt is supported by frictionless rollers and moves at a constant speed of  $0.75 \text{ m s}^{-1}$  under the action of a constant horizontal external force  $F_{ext}$  supplied by the motor that drives the belt.

Calculate:

- (i) the force of friction exerted by the belt on the sand;

Frictional force = ..... N [2]

- (ii) the external force  $F_{ext}$ , giving your reason.

$F_{ext}$  = ..... N [2]

(iii) the power due to  $F_{ext}$ ;

Power = ..... W [2]

(iv) the rate of change of kinetic energy of the sand due to the change in its horizontal motion;

Rate = ..... W [2]

Compare and analyse the answers to (c)(iii) and (c)(iv).

.....  
.....  
.....  
..... [2]

- 8 (a)** The speed of the wave set up in a vibrating string is given by

$$v = \sqrt{\frac{T}{\mu}}$$

where  $T$  is the tension in the string, and  $\mu$  is the mass per unit length of the string. On a particular piano note, the mass per unit length of the string is  $0.030 \text{ kg m}^{-1}$  and the tension in it is  $275 \text{ N}$ . The string is  $0.87 \text{ m}$  long and it vibrates at a frequency of  $55 \text{ Hz}$ .

- (i)** Show using base units that the equation above is homogeneous.

[2]

- (ii)** Calculate the speed of the wave in the vibrating string.

Speed = .....  $\text{m s}^{-1}$  [2]

- (iii)** Calculate the wavelength of the stationary wave.

Wavelength = .....  $\text{m}$  [2]

- (iv)** Sketch a diagram of the stationary wave formed and label the length of the string.

[1]

- (v)** If the speed of sound in air is  $340 \text{ m s}^{-1}$ , calculate the wavelength of the sound when this note is heard.

Wavelength = .....  $\text{m}$  [1]

- (vi) Explain why sound is characterized by its frequency rather than its wavelength.

.....  
.....  
..... [2]

- (b) A pipe is open at both ends, while another is closed at one end. Two **consecutive** resonances corresponding to stationary waves are heard at 264 Hz and 440 Hz for one of the pipes.

- (i) By drawing the 3 lowest modes of oscillation in the pipe open at one end, show that

$$\left(\frac{2n-1}{4}\right)\lambda = L$$

where  $n = 1, 2, 3, \dots$

[3]

- (ii) By drawing the 3 lowest modes of oscillation in the pipe open at both ends, derive an expression involving  $n$ ,  $\lambda$  and  $L$ .

[3]

- (iii) Determine whether the pipe open at both ends can produce the two resonances of 264 Hz and 440 Hz.

[4]

- 9 (a)** In a photoelectric emission experiment, ultra-violet radiation, of wavelength 254 nm and of intensity of  $210 \text{ W m}^{-2}$ , was incident on a silver surface in an evacuated tube, so that an area of  $12 \text{ mm}^2$  was illuminated.

A photocurrent of  $4.8 \times 10^{-10} \text{ A}$  was measured.

- (i)** Calculate the rate of incidence of photons on the silver surface.

Rate of incidence = .....  $\text{s}^{-1}$  [3]

- (ii)** Calculate the rate of emission of electrons.

Rate of emission = .....  $\text{s}^{-1}$  [2]

- (iii)** The photoelectric quantum yield is defined as the ratio of

$$\frac{\text{number of photoelectrons emitted per second}}{\text{number of photons incident per second}},$$

- 1** Calculate the quantum yield of this silver surface at the wavelength of 254 nm.

Quantum yield = ..... [1]

2 Suggest two reasons why this value is expected to be much less than one.

.....  
 .....  
 ..... [2]

(iv) When the experiment was repeated with visible radiation, no photoelectrons were emitted. Explain this observation.

.....  
 .....  
 ..... [2]

(b) **Fig. 9.1** shows the setup for another experiment on the photoelectric effect. X and Y are electrodes made of different metals and placed in an evacuated chamber.

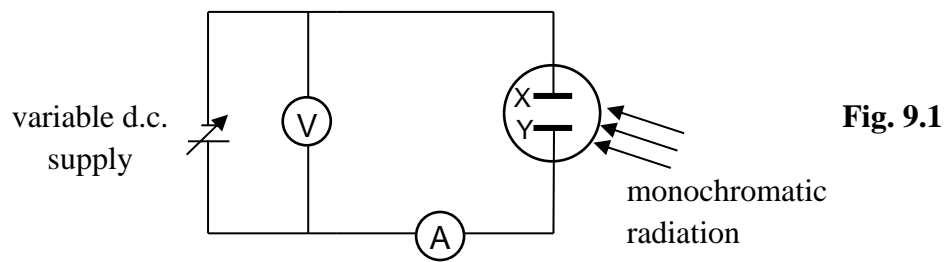

X and Y were both illuminated by monochromatic radiation and the photocurrent  $I$  was measured as the potential difference across them was varied. When the wavelength of the light was  $\lambda_1$ , the  $I$ - $V$  characteristic was as shown in **Fig. 9.2**.

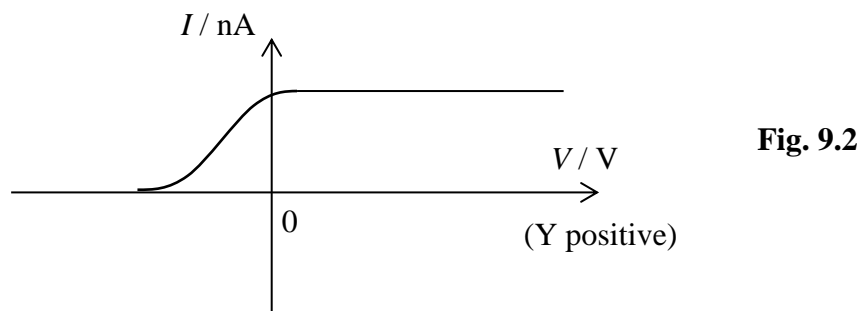

When the wavelength of the light was  $\lambda_2$ , the  $I$ - $V$  characteristic is as shown in **Fig. 9.3**.

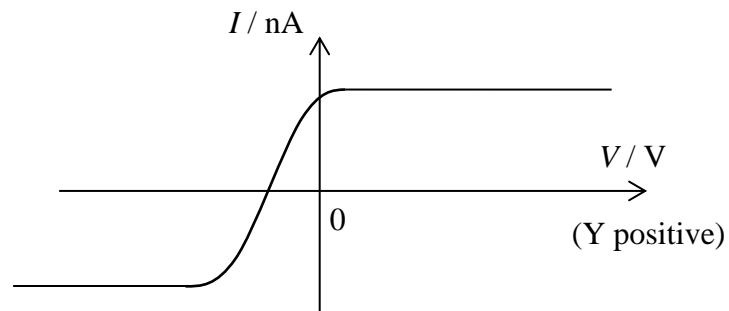

**Fig. 9.3**

(i) State and explain which wavelength,  $\lambda_1$  or  $\lambda_2$ , is shorter.

.....  
 .....  
 ..... [2]

(ii) State and explain which electrode, X or Y, has the higher work function energy.

.....  
 .....  
 ..... [1]

(c) The energy diagram in **Fig. 9.4** shows a simplified representation of the four lowest energy levels of the outermost electron in the sodium atom.

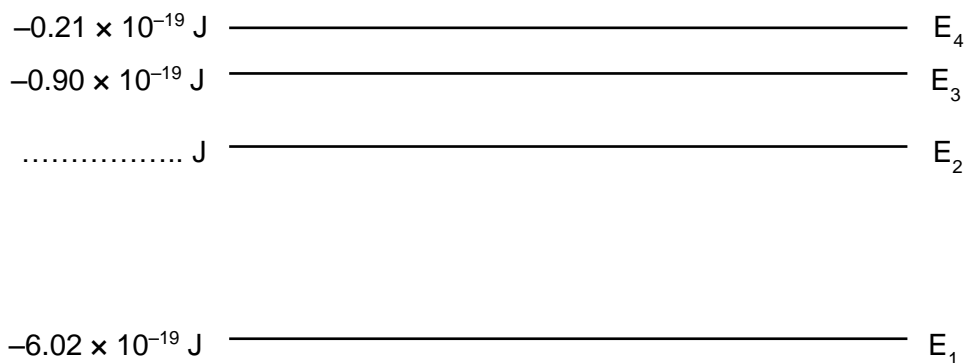
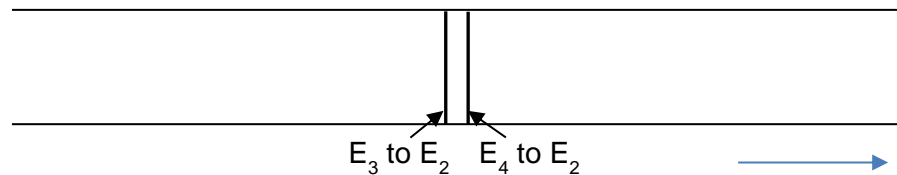

**Fig. 9.4**



(i) When the electron in the sodium atom transits from energy level  $E_4$  to  $E_2$ , a photon of wavelength 820 nm is produced. Complete **Fig. 9.4** with the value of energy level  $E_2$ . [1]

(ii) In the emission line spectrum in **Fig. 9.5**, the photons produced from the transitions  $E_4$  to  $E_2$  and  $E_3$  to  $E_2$  are shown. Without further calculation, sketch and label the emission lines for **all the transitions to  $E_1$** . [2]



**Fig. 9.5** Increasing frequency

(iii) State, with explanation, the possible upward transitions that can take place for a cool sodium atom that is initially in the ground state when it is bombarded with the following:

1 a photon of energy  $5.21 \times 10^{-19}$  J,

.....  
 .....  
 ..... [2]

2 an electron with a kinetic energy of  $5.9 \times 10^{-19}$  J.

.....  
 .....  
 ..... [2]

\*\*\*\*\* END \*\*\*\*\*

VICTORIA JUNIOR COLLEGE  
 SUGGESTED SOLUTIONS TO 2017  
 PHYSICS PRELIM EXAMS 8866  
 H1P2

Section A

Q1(a)(i)  $v_c = v \cos \theta$

1(a)(ii) From conservation of energy, loss of KE from A to D = gain in GPE

$$\frac{1}{2}mv^2 - \frac{1}{2}mv_D^2 = mgH$$

$$v_D = \sqrt{v^2 - 2gH}$$

1(a)(iii)

The dotted path is when resistance is significant.

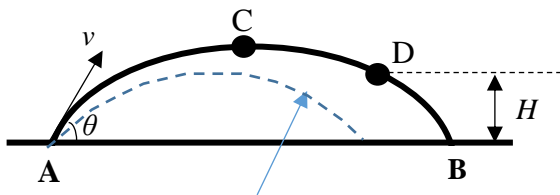

Path where air resistance is significant

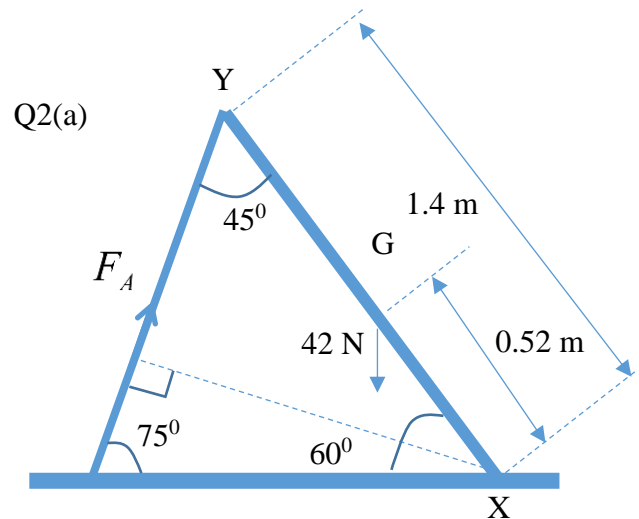

Taking moments about X,

Sum of clockwise moments = sum of anti-clockwise moments

$$(F_A)(1.4 \sin 45^\circ) = 42 [0.52 \cos 60^\circ]$$

$$F_A = 11 \text{ N}$$

2b(i) For translational equilibrium, the resultant force acting on the bar must be zero.

A force at X is required to balance the horizontal component of the force  $F_A$ .

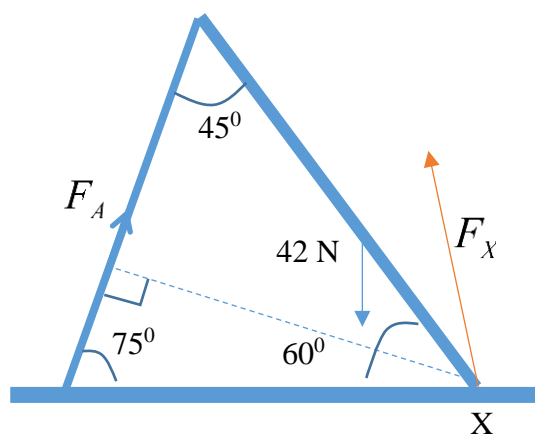

$$\text{Q3(a) } KE = \frac{1}{2}mv^2 = 0.5 \times 1300 \times (16.7)^2$$

$$= 1.81 \times 10^5 \text{ J}$$

3(b)(i) Let total external forces opposing motion of car be  $R$ . Then driving force  $F = R$  since velocity is constant.

$$P = Fv = (240 + 0.98v^2) \times v$$

$$R = 240 + 0.98v^2 = 240 + 0.98(16.7)^2 = \mathbf{513 \text{ N}}$$

3(b)(ii) Work done = Force x Distance  
=  $R$  x velocity x time

$$= 513 \times 16.7 \times (3 \times 60) = \mathbf{1.54 \times 10^6 \text{ J}}$$

Q4(a) p.d. across voltmeter is

$$V = \frac{R_v}{R_v + r} E$$

4(b) If the voltmeter reading is within 0.1 % of the e.m.f.,

$$\frac{E - V}{E} \leq 0.001$$

$$1 - \frac{V}{E} \leq 0.001 \text{ or } 1 - \frac{R_v}{R_v + r} \leq 0.001$$

$$\therefore \frac{r}{R_v + r} \leq 0.001$$

$$\therefore 1000r \leq R_v + r$$

$$\therefore R_v \geq 999r = 999 \times 0.10 = 99.9$$

$$\therefore R_{v(\min)} = \mathbf{99.9 \Omega}$$

4(c) The voltmeter and the resistor  $R$  form a parallel load resistance that the cell is connected across.

The equivalent resistance of the voltmeter and resistor  $R$  in parallel is:

$$R_{\parallel} = \frac{R_v \times R}{R_v + R}$$

By the voltage divider rule, the voltmeter reading is

$$V = \frac{R_{\parallel}}{R_{\parallel} + r} \times E$$

$$V = \frac{\frac{R_v \times R}{R_v + R}}{\frac{R_v \times R}{R_v + R} + r} \times E$$

$$V = \frac{R_v R}{R_v R + r R_v + r R} \times E$$

Q5(a)

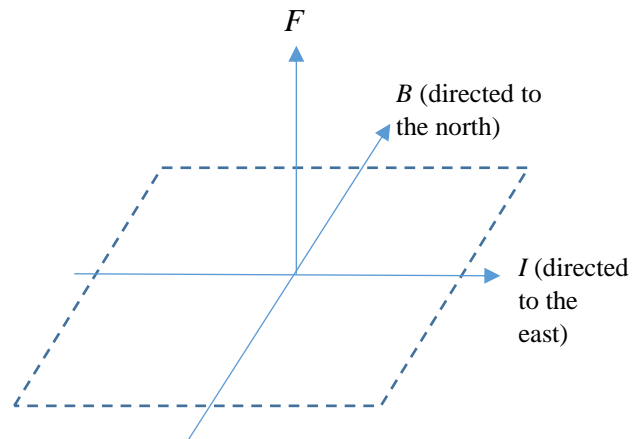

$$5(b) R = \rho \frac{L}{\pi r^2}$$

$$= \frac{(2.0 \times 10^{-8})(10)}{\pi(0.457 \times 10^{-3})^2} \approx \mathbf{0.305 \Omega \approx 0.31 \Omega}$$

5(c) To cause the wire to rise from the table,  $BIL \geq mg$  or  $B\left(\frac{V}{R}\right)L \geq D(\pi r^2 L)g$

$$\text{Or } V_{\min} = \frac{D\pi r^2 g R}{B}$$

$$= \frac{(1.0 \times 10^4)\pi(0.457 \times 10^{-3})^2(9.81)(0.305)}{1.8 \times 10^{-5}}$$

$$\approx \mathbf{1.09 \times 10^3 \text{ V}}$$

Q6(a)(i)  $F_B = -F_A$

6(a)(ii)  $t_B = t_A$

6(b) Let  $\Delta p_A$  and  $\Delta p_B$  be change in momentum for A and B respectively. By the impulse-momentum theorem, impulse = change in momentum of a body.

Impulse on A =  $F_A t_A = \Delta p_A$

Impulse on B =  $F_B t_B = \Delta p_B$

Since  $F_A = -F_B$ , we have

$F_A t_A = -F_B t_B$  or  $\Delta p_A = -\Delta p_B$

6(c)(i) Taking right as positive, change in momentum of A is

$\Delta p_A = -3.0 - 6.0 = -9.0 \text{ kg m s}^{-1}$

Let final momentum of sphere B be

$p_{B(f)}$

$p_{B(f)} - (-4.0) = 9.0$  since  $\Delta p_A = -\Delta p_B$

Hence  $p_{B(f)} = 5.0 \text{ kg m s}^{-1}$

6(c)(ii)

Momentum to the right N s

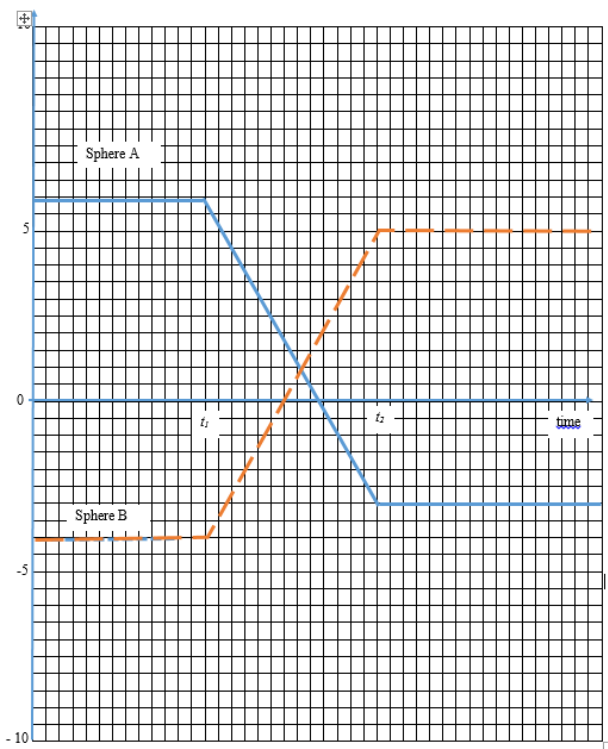

6(d) From the graph, the initial and final momenta of sphere A are  $6.0 \text{ kg m s}^{-1}$  and  $-3.0 \text{ kg m s}^{-1}$  respectively.

Since initial velocity  $u_A = 3.0 \text{ m s}^{-1}$ , the

mass of sphere A is  $m_A = \frac{6.0}{3.0} = 2.0 \text{ kg}$

Final velocity is  $= -\frac{3.0}{2.0} = -1.5 \text{ m s}^{-1}$

6(e)  $\frac{p_{B(f)}}{p_{B(i)}} = \frac{v_B}{u_B}$

$\therefore \frac{v_B}{u_B} = \frac{5.0}{-4.0} = -1.25$

6(f) Given  $m_B = 1.0 \text{ kg}$ ,

Now kinetic energy

$K = \frac{1}{2} m v^2 = \frac{m^2 v^2}{2m} = \frac{p^2}{2m}$

Total initial KE is  $K_i = \frac{6.0^2}{2(2)} + \frac{(-4.0)^2}{2(1)} = 17 \text{ J}$

Total final KE is  $K_f = \frac{(-3.0)^2}{2(2)} + \frac{(5.0)^2}{2(1)}$

$\approx 14.8 \text{ J}$

Since there has been a loss of total KE, the collision is **inelastic**.

**Section B**

Q7(a)(i)

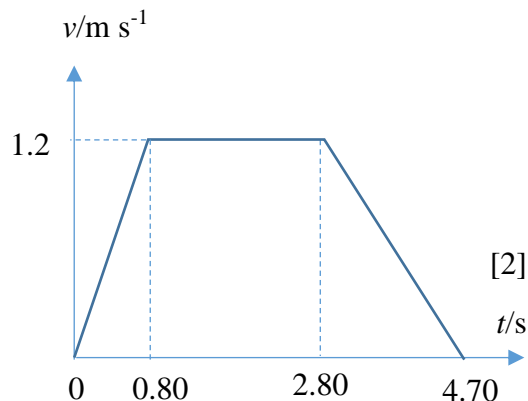

7(a)(ii) When Bob is at rest or moving at constant velocity, the spring balance will just read his actual weight  $W = mg = 71 \times 9.81 = 697 \text{ N}$ .

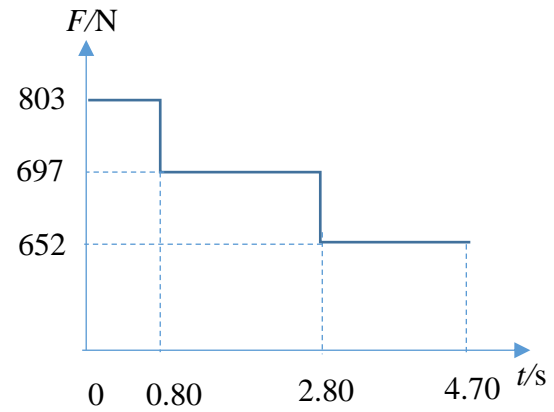
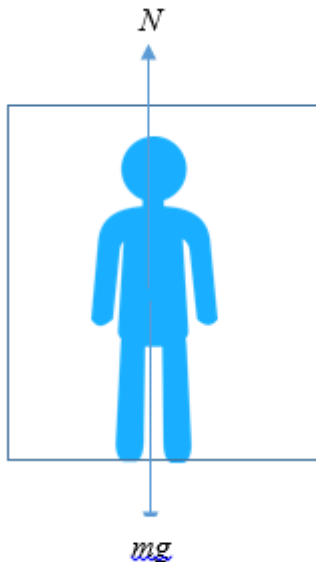

7(b)(i)

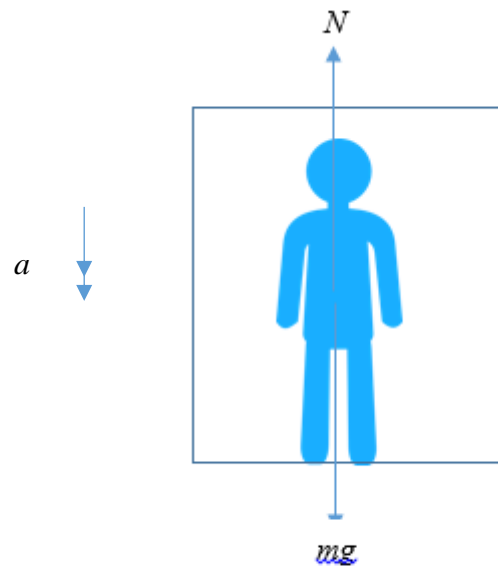

When accelerating while ascending, using N2L,  $N - mg = ma$  where  $N$  = normal reaction exerted by floor on Bob and

$$a = \frac{1.2 - 0}{0.80 - 0} = 1.5 \text{ m s}^{-2}$$

Hence  $N = 71 \times 9.81 + 71 \times (1.5)$

$\approx 803 \text{ N}$

By N3L, this is also the force which Ah Beng exerts on the floor of the elevator, or his effective weight.

When decelerating while still ascending,

$$a = \frac{0 - 1.2}{4.70 - 2.80} \approx -0.632 \text{ m s}^{-2}$$

Hence  $N = 71 \times 9.81 - 71 \times 0.632$

$\approx 652 \text{ N}$

By Newtons' Second Law,  $mg - N = ma$ .

Hence  $N = mg - ma$

Hence, Bob feels lighter as the floor pushes against him with a force smaller than his weight.

7(b)(ii) Here  $a = g$  (free fall).

From  $N = mg - ma$ ,  $N = 0$ . As the floor is not pushing against Bob with any force, it means Bob is weightless.

7(c)(i) When the sand impacts on the conveyor belt, it has zero initial horizontal velocity. Friction drags the sand particles along the surface of the conveyor belt, causing the sand to attain a final horizontal velocity of  $v = 0.75 \text{ m s}^{-1}$ . Hence

$$\text{From N2L, } f = ma = \frac{m(v-0)}{t}$$

$$= (5.00)(0.75) = \mathbf{3.75 \text{ N}}$$

7(c)(ii) The external force is opposed by the force exerted on the conveyor belt by the sand particles.

By Newton's 3<sup>rd</sup> Law, this force is numerically 3.75 N. Hence  $F_{ext} = \mathbf{3.75 \text{ N}}$

7(c)(iii) Power due to  $F_{ext}$  is  $P = F_{ext} v$

$$= 3.75 (0.75) \approx \mathbf{2.81 \text{ J s}^{-1}}$$

7(c)(iv) Rate of change of kinetic energy is

$$\frac{dK}{dt} = \frac{d}{dt} \left( \frac{1}{2} mv^2 \right) = \frac{1}{2} v^2 \left( \frac{dm}{dt} \right)$$

$$= \frac{1}{2} (0.75^2)(5.00) \approx \mathbf{1.41 \text{ J s}^{-1}}$$

The rate of change of kinetic energy of the sand is half of the power due to  $F_{ext}$ .

Half of the work done by the external force is due to work done to overcome friction between the sand and the conveyor belt.

$$8(a)(i) v = (T/\mu)^{1/2}$$

Let BU stand for base units.

$$\text{LHS BU} = \text{m s}^{-1}$$

$$\text{RHS BU} = \left( \frac{\text{kg m s}^{-2}}{\text{kg m}^{-1}} \right)^{\frac{1}{2}} = \text{m s}^{-1}$$

Since BU on both sides of the equation sign are the same, the equation is homogeneous.

$$8(a)(ii) v = (275/0.030)^{1/2}$$

$$= \mathbf{95.7 \text{ m s}^{-1}}$$

$$8(a)(iii) v = f\lambda$$

$$\lambda = 95.7/55$$

$$= \mathbf{1.74 \text{ m}}$$

8(a)(iv)

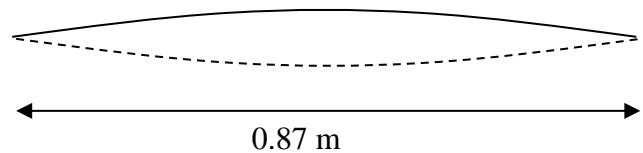

$$8(a)(v) v = f\lambda$$

$$\lambda = 340/55$$

$$= \mathbf{6.2 \text{ m}}$$

8(a)(vi) The frequency that is heard by the ear is the same as the vibration of the string.

The wavelength of the stationary wave in the string is different from the wavelength of the sound heard at a particular frequency, i.e. wavelength is affected by the medium the wave travels in.

8(b)(i)

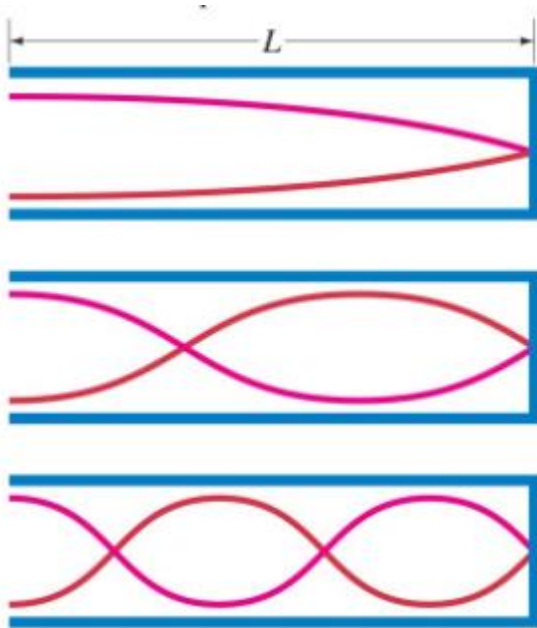

The three modes of oscillation correspond to  $\frac{1}{4}\lambda = L$ ,  $\frac{3}{4}\lambda = L$  and  $\frac{5}{4}\lambda = L$

Hence the modes of oscillation can be represented by  $\left(\frac{2n-1}{4}\right)\lambda = L$  where  $n = 1, 2, 3$

8(b)(ii)

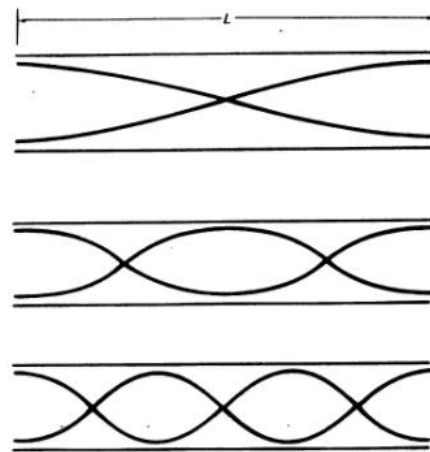

Here the modes of oscillation correspond to  $\frac{\lambda}{2} = L$ ,  $\frac{2\lambda}{\lambda} = L$  and  $\frac{3\lambda}{2} = L$

Hence  $\frac{n\lambda}{2} = L$  where  $n = 1, 2, 3, \dots$

8(b)(iii) For a pipe of length  $L$  that is open at both ends,  
 $n\lambda / 2 = L$   
 where  $n = 1, 2, 3, \dots$

Let  $n$  be the integer corresponding to the 264 Hz resonance, and  $v$  be the speed of sound.  
 $nv/[2(264)] = L$

Let  $n + 1$  be the integer corresponding to the 440 Hz.  
 $(n + 1)v/[2(440)] = L$

Solving,  $n = 1.5$ , which is not an integer.

Hence the pipe open at both ends cannot produce the two resonances of 264 Hz and 440 Hz.

$$\text{Q9(a)(i) Intensity} = \frac{\text{power}}{\text{area}}$$

$$= \frac{E}{t} \times \frac{1}{\text{area}} = \frac{nhf}{t \times \text{area}}$$

$$\text{hence, } \frac{n}{t} = \frac{Int \times \text{area}}{hf} = \frac{Int \times \text{area}}{hc / \lambda}$$

$$= \frac{210 \times 12 \times 10^{-6}}{6.63 \times 10^{-34} \times 3 \times 10^8 \div (254 \times 10^{-9})} \text{ s}^{-1}$$

$$= \mathbf{3.22 \times 10^{15} \text{ s}^{-1}}$$

9(a)(ii)

$$I = \frac{Q}{t} = \frac{ne}{t}, \text{ hence } \frac{n}{t} = \frac{I}{e}$$

$$\frac{n}{t} = \frac{4.8 \times 10^{-10}}{1.6 \times 10^{-19}} = \mathbf{3.0 \times 10^9 \text{ s}^{-1}}$$

9(a)(iii)1.

$$\frac{\text{number of photoelectrons emitted per second}}{\text{number of photons incident per second}}$$

$$= \frac{3.0 \times 10^9}{3.22 \times 10^{15}}$$

$$= \mathbf{9.32 \times 10^{-7}}$$

9(a)(iii)2. Some of the incident radiation may interact with entire atoms causing them to vibrate more vigorously.

Incident light may also be reflected away from the metal surface and thus cannot interact with and eject electrons.

*[Accept : The atom is mostly empty space. The chance of a photon-electron interaction is extremely small.]*

9(a)(iv) Visible radiation has a wavelength longer than that of ultra-violet radiation.

This wavelength is apparently longer than the threshold wavelength of the metal, and so no photoelectric emission can occur.

9(b)(i) When  $\lambda_1$  alone is used, only electrode X emits photoelectrons, whereas when  $\lambda_2$  is used, both electrodes X and Y emit photoelectrons.

Hence  $\lambda_2$  must be more energetic and  $\lambda_2$  is therefore shorter than  $\lambda_1$ .

9(b)(ii) Since electrode X emits photoelectrons more easily than electrode Y, the work function of X is smaller than that of Y.

$$\text{9(c)(i) Using } E = hc / \lambda$$

$$= \frac{6.63 \times 10^{-34} \times 3 \times 10^8}{(820 \times 10^{-9})} = 2.43 \times 10^{-19} \text{ J} ,$$

$$E_4 - E_2 = 2.43 \times 10^{-19}$$

$$\text{Hence the energy level } E_2 =$$

$$(-0.21 \times 10^{-19}) - 2.43 \times 10^{-19}$$

$$= \mathbf{-2.64 \times 10^{-19} \text{ J}}$$

9(c)(ii)

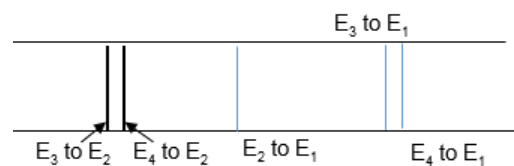

9(c)(iii)1. No transitions occur.

The atom is unable to absorb the photon and undergo excitation. The photon energy does not match exactly the difference in energy levels between  $E_1$  and the other energy levels.



9(c)(iii)2.

Transition  $E_1$  to  $E_2$ , energy required

$$= -2.64 \times 10^{-19} - (-6.02 \times 10^{-19})$$

$$= 3.38 \times 10^{-19} \text{ J}$$

$$E_1 \text{ to } E_3, \text{ energy required} = 5.12 \times 10^{-19} \text{ J}$$

$$E_1 \text{ to } E_4, \text{ energy required} = 5.81 \times 10^{-19} \text{ J}$$

All the above transitions are possible because the incoming electron has energy  $5.9 \times 10^{-19} \text{ J}$  which is bigger than energies required for the above-mentioned transitions.

\*\*\*\*\* END \*\*\*\*\*