

Candidate's name

CTG

YISHUN JUNIOR COLLEGE JC 2 PRELIMINARY EXAMINATIONS 2017

**PHYSICS
HIGHER 1**

**8866/1
15th September 2017
1 hour**

Paper 1 Multiple Choice

Additional Material:
Optical Mark Sheet



READ THESE INSTRUCTIONS FIRST

Do not open this booklet until you are told to do so.

Write your name and CTG on the Optical Mark Sheet in the spaces provided.
Shade your NRIC in the space provided.

There are **thirty** questions in this paper. Answer **all** questions. For each question there are four possible answers **A, B, C** and **D**.

Choose the **one** you consider correct and record your choice in **soft pencil** on the separate Optical Mark Sheet.

Read the instructions on the Optical Mark Sheet carefully.

INFORMATION FOR CANDIDATES

Each correct answer will score one mark. A mark will not be deducted for a wrong answer.
Any rough working should be done in this booklet.

Data

speed of light in free space,	$c = 3.00 \times 10^8 \text{ m s}^{-1}$
elementary charge,	$e = 1.60 \times 10^{-19} \text{ C}$
the Planck constant,	$h = 6.63 \times 10^{-34} \text{ J s}$
unified atomic mass constant,	$u = 1.66 \times 10^{-27} \text{ kg}$
rest mass of electron,	$m_e = 9.11 \times 10^{-31} \text{ kg}$
rest mass of proton,	$m_p = 1.67 \times 10^{-27} \text{ kg}$
acceleration of free fall	$g = 9.81 \text{ m s}^{-2}$

Formulae

uniformly accelerated motion,	$s = ut + \frac{1}{2}at^2$
	$v^2 = u^2 + 2as$
work done on/by a gas,	$W = p\Delta V$
hydrostatic pressure,	$p = \rho g h$
resistors in series,	$R = R_1 + R_2 + \dots$
resistors in parallel,	$\frac{1}{R} = \frac{1}{R_1} + \frac{1}{R_2} + \dots$

- 1 The intensity of a beam is defined as the energy delivered per unit area per unit time. What is the base unit of intensity?

A $\text{kg m}^2 \text{s}^{-3}$ B kg m s^{-3} C kg s^{-2} D kg s^{-3}

- 2 Errors in measurement may be either systematic or random.

Which of the following involves random error?

- A Not accounting for zero error on a moving-coil voltmeter.
B Using a stopwatch to determine the time to complete a race.
C Using the outer diameter of the beaker when calculating the volume of water in the beaker.
D Using the value of g as 10 m s^{-2} when calculating weight from mass.

- 3 Car A and car B were having a race along a straight line towards the finishing line. Car A was moving at a speed of 40 m s^{-1} and car B was moving at a speed of 50 m s^{-1} when car B overtook car A. After 1.0 s of reaction time, car A accelerated to 55 m s^{-1} uniformly in another 1.0 s . Car A then moved at that constant speed.

What is the total time taken for car A to catch up with car B? Assume that car B maintained a constant velocity throughout?

A 1.3 s B 2.2 s C 4.5 s D 17.5 s

- 4 A tennis ball is projected with an initial speed of 10.0 m s^{-1} at an angle of 30° from the horizontal towards a vertical wall 10.0 m away.

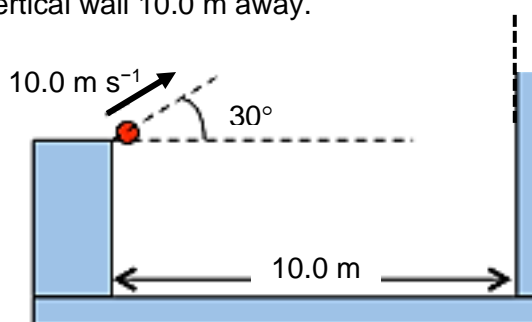

What is the speed of the ball when it hits the wall?

A 6.3 m s^{-1} B 10.7 m s^{-1} C 12.0 m s^{-1} D 18.5 m s^{-1}

- 5 Which of the following statements is true?
- A When an object is thrown upwards, its acceleration at the highest point is zero.
 - B When an object is in motion, its velocity and acceleration are always in the same direction.
 - C When the velocity of an object is zero, its acceleration can be non-zero.
 - D When the acceleration of an object is non-zero, its speed must be changing.
- 6 A child is sitting on a moving cart which is pulled towards the right by a constant force F .

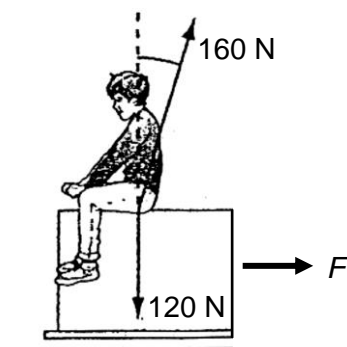

The resultant force that the cart exerts on the child is 160 N and the weight of the child is 120 N.

What is the acceleration of the child?

- A 0.88 m s^{-2}
 - B 3.3 m s^{-2}
 - C 8.7 m s^{-2}
 - D 84 m s^{-2}
- 7 A constant mass undergoes uniform non-zero acceleration.
- Which of the following is a correct statement about the momentum of the mass?
- A It increases uniformly with respect to time.
 - B It is increasing at a decreasing rate with respect to time.
 - C It is increasing at an increasing rate with respect to time.
 - D It is constant but non-zero.

- 8 A ball falls vertically and bounces on the ground. The following statements describe the forces acting while the ball is in contact with the ground.

Which statement is correct?

- A The force that the ball exerts on the ground is always equal to the weight of ball.
- B The force that the ball exerts on the ground is always equal in magnitude and opposite in direction to the force ground exerts on ball.
- C The force that the ball exerts on the ground is always greater than the weight of ball.
- D The weight of ball is always equal and opposite to the force that the ground exerts on ball.

- 9 The spring suspension system of a car obeys Hookes' law. The following data is provided:

mass of passengers = 450 kg

mass of car and passengers = 2000 kg

difference in height of car when passengers alight = 0.100 m

What is the spring constant of the spring suspension system?

- A $4.50 \times 10^3 \text{ N m}^{-1}$
 - B $1.55 \times 10^4 \text{ N m}^{-1}$
 - C $4.41 \times 10^4 \text{ N m}^{-1}$
 - D $1.52 \times 10^5 \text{ N m}^{-1}$
- 10 What is not true of two forces that give rise to a couple?
- A They act in opposite directions.
 - B They both act at the same point.
 - C They both act on the same body.
 - D They both have the same magnitude.

- 11 A 1.00 m non-uniform rod of weight 10.0 N is freely hinged to a wall at pivot P. A force of 8.20 N acts on the other end of the rod such that the rod remains horizontal. The centre of gravity of the rod is at a distance d from P.

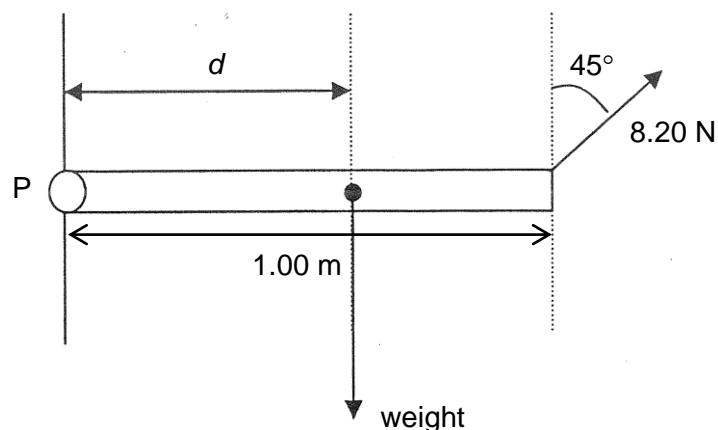

What is the value of d ?

- A 0.180 m B 0.420 m C 0.580 m D 0.820 m
- 12 The driving force F of a car of mass m causes the car to accelerate. In a time t , it travels a distance s and its speed increases from u to v .

What is the useful work done by the car engine?

- A Ft B $\frac{Fs}{t}$ C $m(v - u)$ D $\frac{m(v^2 - u^2)}{2}$
- 13 A car of mass 1.2×10^3 kg travels along a horizontal road at a speed of 10 m s^{-1} . It then accelerates at 0.20 m s^{-2} . At the time it begins to accelerate, the total resistive force acting on the car is 160 N.

What total output power is developed by the car as it begins the acceleration?

- A 0.80 kW B 1.6 kW C 2.4 kW D 4.0 kW

- 14 The diagram shows a transverse wave at a particular instant. The wave is travelling to the right. The frequency of the wave is 12.5 Hz.

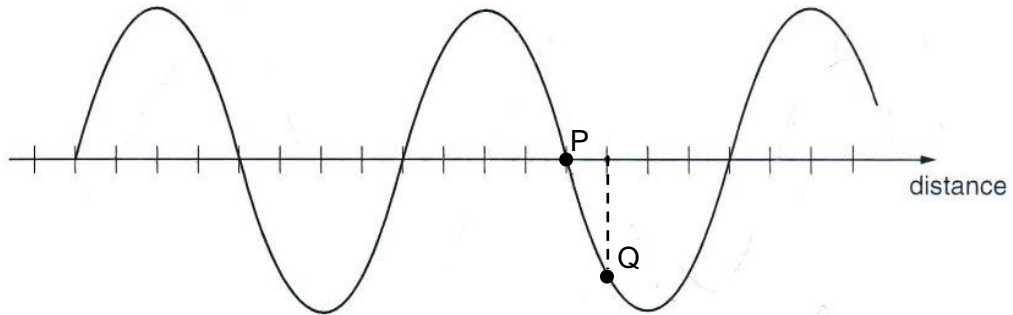

At the instant shown, the displacement of particle P is zero.

What is the shortest time to elapse before the displacement of particle Q is zero?

- A 0.010 s B 0.030 s C 0.080 s D 0.10 s
- 15 Three polarisers are placed facing one another. The axis of polarisation of polariser A is vertical, of B is at an angle of θ from the vertical, and of C is horizontal. A light beam is shone at A, as shown.

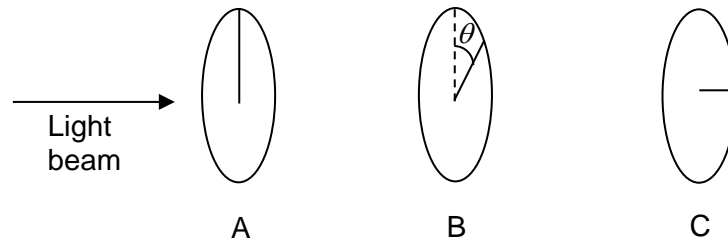

Which of the following graphs shows how the intensity I of the emergent light beyond C will vary with θ ?

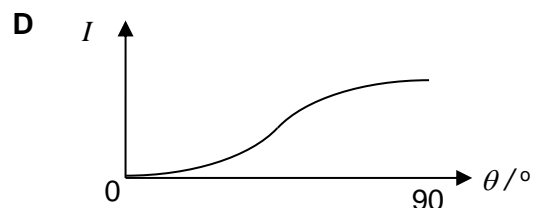
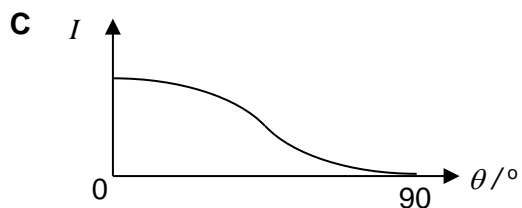
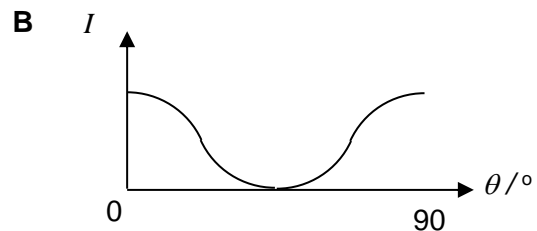
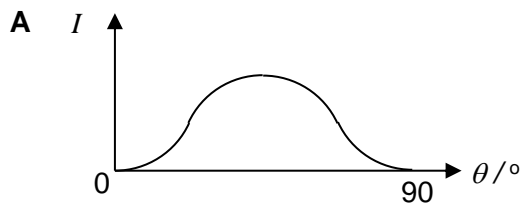

- 16 In a double-slit experiment, the slit separation is 2.0 mm, and two wavelengths of light, 750 nm and 900 nm, illuminate the slits. A screen is placed 2.0 m from the slits.

What is the minimum distance from the central maximum on the screen that a maximum from one pattern coincide with the maximum from the other?

- A 1.5 mm B 3.0 mm C 4.5 mm D 6.0 mm

- 17 Two coherent wave-trains of monochromatic light arrives at a point on a screen. Which one of the following statements must be true?

- A They are in phase.
 B They have a constant phase difference.
 C They interfere constructively.
 D They interfere destructively.

- 18 Diagram 1 shows a ripple tank experiment in which plane waves are diffracted through a narrow slit in a metal sheet.

Diagram 2 shows the same tank with a slit of greater width.

In each case, the pattern of waves incident on the slit and the emergent pattern are shown.

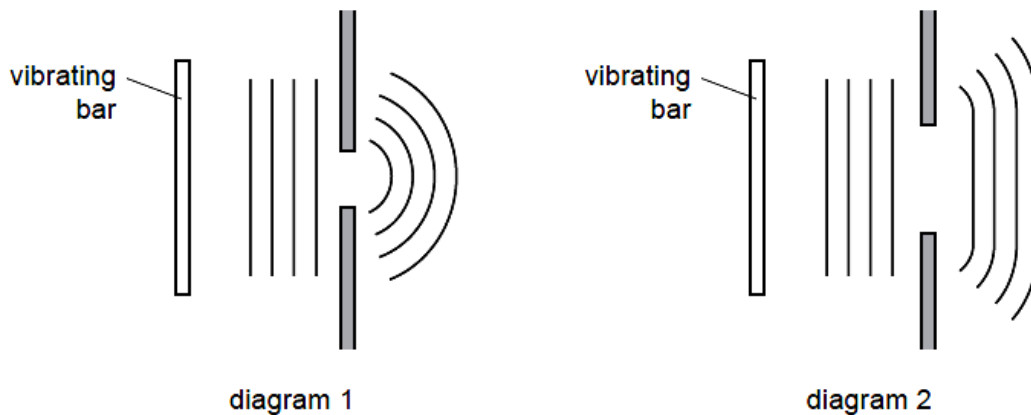

Which of the following changes would cause the waves in diagram 2 to diffract more and produce an emergent pattern closer to that shown in diagram 1?

- A Increase the speed of the waves by making the water in the tank deeper
 B Increase the frequency of vibration of the bar
 C Reduce the amplitude of vibration of the bar
 D Reduce the length of the vibrating bar

- 19 Aluminium and copper cylindrical rods are designed to have the same length and the same resistance. The resistivity of copper is half that of aluminium and its density is three times that of aluminium.

What is the ratio of the mass of the copper rod to the mass of aluminium rod?

- A 0.167 B 0.667 C 1.50 D 6.00

- 20 A cell with internal resistance of 1.2Ω is connected to a load of resistance R of 4.8Ω .

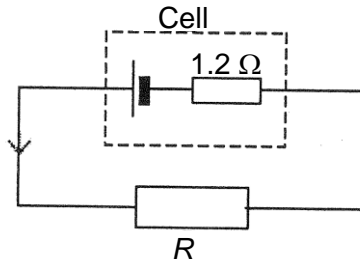

What is the ratio of power dissipated in R to the total power supplied by the e.m.f. source?

- A 0.20 B 0.25 C 0.80 D 4.0

- 21 An ideal 6.0 V e.m.f source is connected in series with a 6.0Ω resistor and a variable resistor. The resistance of the variable resistor is varied between 0Ω and 4.0Ω .

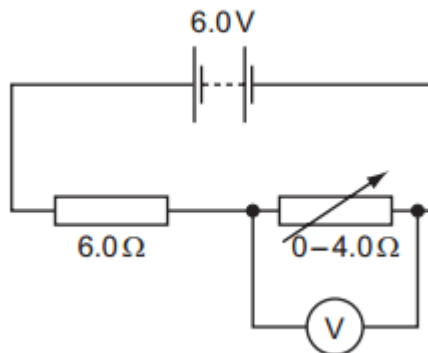

What is the range of the voltmeter reading?

- A 0 V to 2.4 V
 B 0 V to 3.6 V
 C 2.4 V to 6.0 V
 D 3.6 V to 6.0 V

- 22 Three similar light bulbs are connected to a constant voltage d.c. supply of negligible internal resistance. Each bulb operates at normal brightness and the ideal ammeter register a steady current.

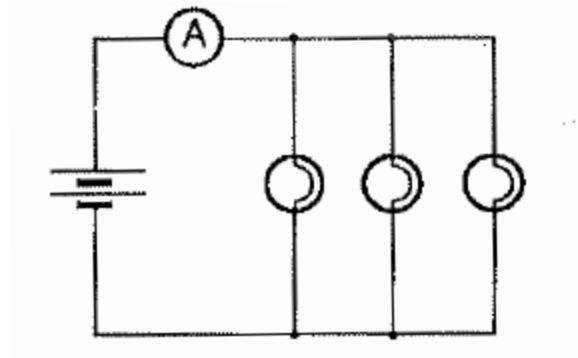

The filament of one of the bulbs breaks.

What happens to the ammeter reading and the brightness of the remaining bulbs?

	<u>ammeter reading</u>	<u>bulb brightness</u>
A	increases	increases
B	increases	remains unchanged
C	decreases	decreases
D	decreases	remains unchanged

- 23 A potential difference of 6.0 V is applied between P and Q.

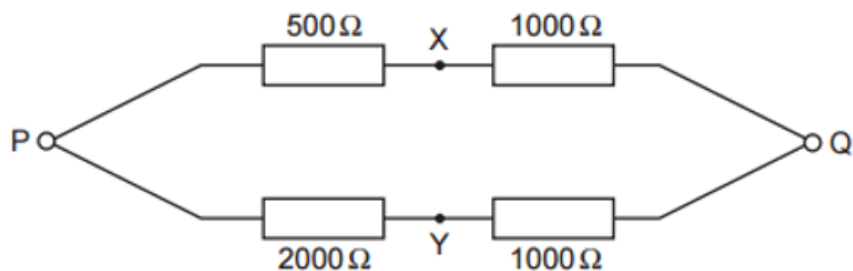

What is the potential difference between X and Y?

- A 0 V B 2 V C 4 V D 6 V

- 24 A straight current-carrying wire lies at right angles to a horizontal magnetic field as shown in diagram A. The field exerts a force of 8.0 mN on the wire.

The wire is now rotated, in its horizontal plane, through 30° and the flux density in the magnetic field is halved, as shown in diagram B.

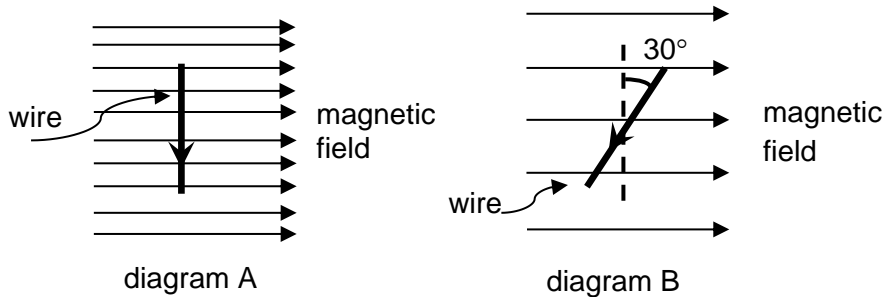

What is the direction and magnitude of the force acting on the wire?

- | | <u>direction</u> | <u>magnitude</u> |
|---|------------------|------------------|
| A | into the plane | 2.0 mN |
| B | out of the plane | 2.0 mN |
| C | into the plane | 3.5 mN |
| D | out of the plane | 3.5 mN |
- 25 A long straight wire P is placed along the axis of a flat circular coil Q. The wire and the coil each carry a current as shown.

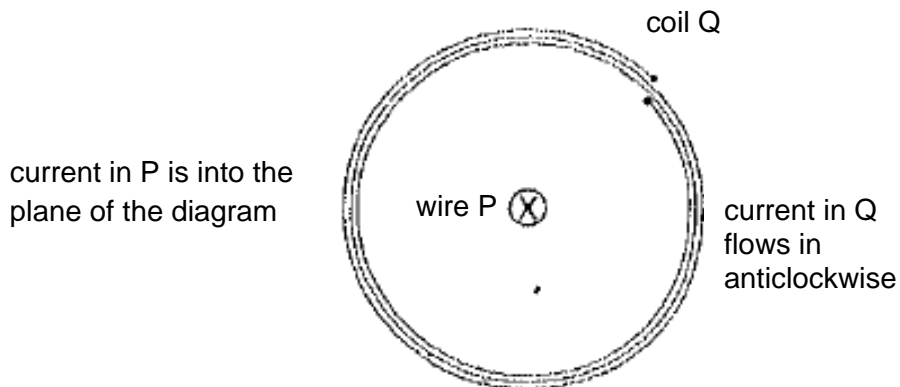

What can be deduced about the force acting on each part of Q due to current in P?

- A There is no force in any direction.
- B The force is towards P.
- C The force is away from P.
- D The force is perpendicular to the plane of the diagram.

- 26 Light falling on a metal surface causes electrons to be emitted from the metal surface. As the intensity of the light is increased, but keeping its wavelength the same, which of the following statement is correct?

- A The maximum speed of the emitted electrons increases.
- B The rate of emission of electrons increases.
- C The work function of the metal increases.
- D The rate of emission of electrons remains constant.

- 27 The graph shows how the stopping potential of emitted electrons is dependent on the frequency of the incoming photon for a certain metal surface.

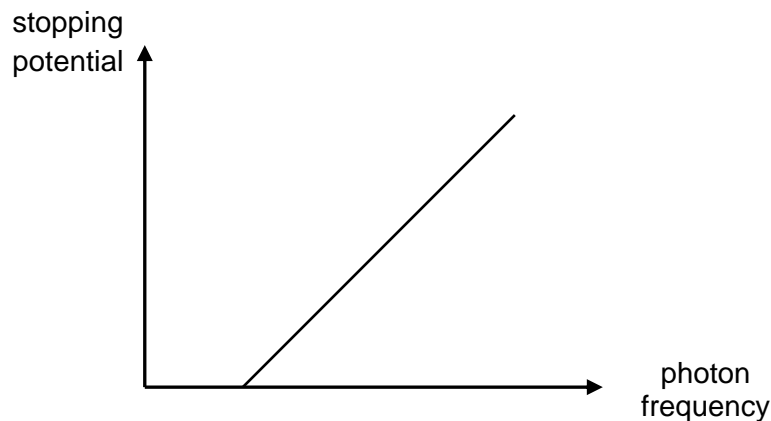

What changes, if any, would occur to the graph when the metal is changed to one with a larger work function?

- | | <u>gradient</u> | <u>x-intercept</u> |
|----------|-----------------|--------------------|
| A | higher | lower |
| B | lower | lower |
| C | same | higher |
| D | same | lower |

- 28 Particle X has a de Broglie wavelength λ . Particle Y has the same mass but twice the kinetic energy of particle X.

What is the de Broglie wavelength of particle Y?

- A** 2λ
- B** $\lambda\sqrt{2}$
- C** $\frac{\lambda}{2}$
- D** $\frac{\lambda}{\sqrt{2}}$

- 29 The diagram shows a cooler region of hydrogen gas surrounding a hot gas cloud emitting white light.

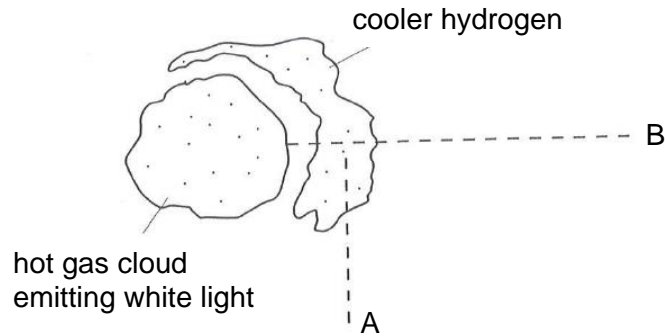

Which of the following describes the type of spectrum observed at point A and B?

	<u>point A</u>	<u>point B</u>
A	continuous	emission
B	emission	absorption
C	absorption	emission
D	continuous	absorption

- 30 The diagram below represents the energy levels for an electron in a certain atom.

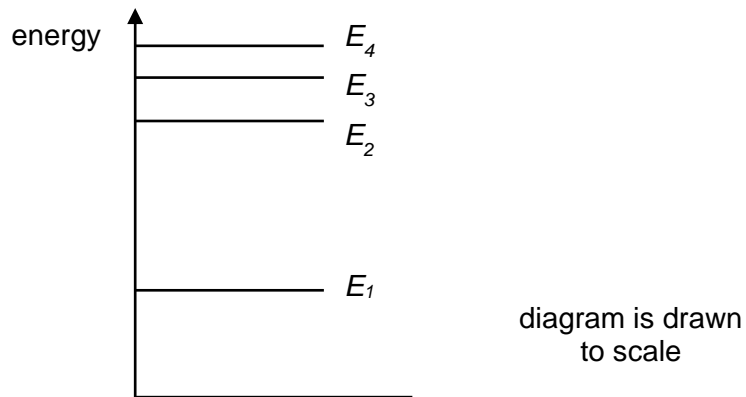

The transition from E_3 to E_1 produces a blue line.

Which transition could give rise to a violet line?

- A E_4 to E_3
- B E_4 to E_1
- C E_3 to E_2
- D E_2 to E_1

--- End of paper ---

2017 8866 JC2 H1 Physics Prelim Paper 1 Solutions

S/N	Answer	Explanation
1	D	<p>Intensity = Power/Area</p> $= \text{Energy}/(\text{Time} \times \text{Area})$ <p>[Intensity] = [Energy]/([Time] × [Area])</p> $= ([\text{Force}] \times [\text{displacement}]/ ([\text{Time}] \times [\text{Area}]))$ $= (\text{kg m s}^{-2} \times \text{m})/(\text{s} \times \text{m}^2)$ $= \text{kg s}^{-3}$
2	B	Human reaction time when using a stopwatch is a random error.
3	C	<p>For car A to catch up with car B, the distance travelled by both cars will be the same.</p> $50t = (40 \times 1) + \frac{1}{2} (40+55)(1) + 55(t-2)$ $t = 4.5 \text{ s}$ <p>Incorrect answers</p> <p>Option D: If students did some careless mistakes</p> $50t = (40 \times 1) + \frac{1}{2} (40+55)(1) + 55(t)$ $t = 17.5 \text{ s}$ <p>Option B: did not understand the use of relative speed</p> <p>Distance travelled by B in 2s = $50 \times 2 = 100 \text{ m}$</p> <p>Distance travelled by A in first second = $40(1)$</p> <p>Distance travelled by A in second second = $40(1) + \frac{1}{2} (55-40)(1)^2 = 47.5 \text{ m}$</p> <p>Distance between A & B = $100 - (40 + 47.5) = 12.5 \text{ m}$</p> <p>Time taken to catch up by A = $12.5 / 55 = 0.23 \text{ s}$ (failed to see that the relative speed between A & B is 5 m s^{-1}, hence should use $12.5 / 5 = 2.5 \text{ s}$)</p> <p>Total time = $2 + 0.23 = 2.2 \text{ s}$</p> <p>Option A: did not understand the question</p> <p>Distance travelled by B = $50t$</p> <p>Distance travelled by A = $ut + \frac{1}{2} (at)^2$</p> $= 40t + \frac{1}{2} (55-40)t^2$ $50t = 40t + \frac{1}{2} (55-40)t^2$ $t = 1.3 \text{ s}$

4	B	<p>Horizontally, $s = ut$ $t = 10 / 10\cos30 = 1.155 \text{ s}$ vertically, $v_y = 10\sin30 - 9.81(1.155) = -6.33 \text{ m s}^{-1}$ $\text{final speed} = ((10\cos30)^2 + (6.33)^2)^{0.5}$ $= 10.7 \text{ m s}^{-1}$</p> <p>Incorrect answers Option A : value belongs to v_y only Option C : incorrect resolution $t = 10 / 10\sin30 = 2 \text{ s}$ $v_y = 10\cos30 - 9.81(2) = -10.96 \text{ m s}^{-1}$ $\text{final speed} = ((10\sin30)^2 + (10.96)^2)^{0.5}$ $= 12.0 \text{ m s}^{-1}$</p> <p>Option D : incorrect sign convention $v_y = 10\sin30 + 9.81(1.155) = -16.33 \text{ m s}^{-1}$ $\text{final speed} = ((10\cos30)^2 + (16.33)^2)^{0.5}$ $= 18.5 \text{ m s}^{-1}$</p>
5	C	<p>Option C: Example a ball being thrown vertically upwards, at the highest point, the velocity is zero but the acceleration is 9.81 m s^{-2} downwards.</p> <p>Incorrect answers Option A: When an object is thrown upwards, its acceleration at the highest point is 9.81 m s^{-2} downwards. Option B: An object which is slowing down, its velocity and acceleration are in opposite directions. Option D: An object in uniform circular motion has a centripetal acceleration, only the direction of the velocity is changing and its speed is not changing.</p>
6	C	<p>Vertically: $\Sigma F_y = 0$ $N - W = 0$ $N = W = 120 \text{ N}$</p> <p>$R = \sqrt{N^2 + f^2}$ $160 = \sqrt{120^2 + f^2}$ $120^2 + f^2 = 25600$ $f = 105.83 \text{ N}$</p> <p>Horizontally: $\Sigma F_x = m a_x$ $f = (W/g) a_x$ $105.83 = (120/9.81) a_x$ $a_x = 8.7 \text{ m s}^{-2}$</p>

7	A	$p = m v$ $p = m (u + a t)$ $p = (m a) t + m u$ Given m , a & u are constants, Plotting a graph of p against t will yield a straight line graph (of linear trend) with gradient = $m a = \text{constant}$ & y -intercept = mu gradient = $dp/dt = m a = \text{constant}$ p is increasing uniformly with respect to t .
8	B	By Newton's Third Law: The two forces indicated in choice B is action reaction pair. The force exerted by the ground will vary during the collision with the ground. It is not a constant force and will not always be greater or equal to the weight of the ball.
9	C	By Hookes' Law: $F = k x$ $k = \Delta F / \Delta x = W_{\text{passengers}} / 0.10$ $= (450)(9.81) / 0.10$ $= 4.41 \times 10^4 \text{ N m}^{-1}$
10	B	For a couple, the line of action of the two forces must not coincide. Hence, both forces cannot act at the same point.
11	C	Clockwise Moment as positive: $\Sigma T_p = 0$ $W d - (F \cos 45^\circ)(L) = 0$ $(10.0)(d) - (8.20 \cos 45^\circ)(1.00) = 0$ $d = 0.580 \text{ m}$
12	D	Useful work done by the car engine = gain kinetic energy of the car $= \frac{1}{2} m v^2 - \frac{1}{2} m u^2$ $= \frac{m(v^2 - u^2)}{2}$
13	D	$\Sigma F = ma$ $F_{\text{driving}} - F_{\text{resistive}} = 1200 (0.20)$ $F_{\text{driving}} = 400 \text{ N}$ $P = F v$ $= 400 (10)$ $= 4000 \text{ W}$
14	A	Phase difference between PQ = $2\pi/8.0$ Time = $T / 8.0 = 1/(8.0)f = 1/(8.0 \times 12.5) = 0.010 \text{ s}$

15	A	<p>When $\theta = 0^\circ$, the light will pass through A, be vertically polarised, and pass through B. But it will be blocked by C. Final intensity = 0.</p> <p>When $\theta = 90^\circ$, the light will pass through A, be vertically polarised, and be blocked by B. Final intensity = 0.</p> <p>When $0^\circ < \theta < 90^\circ$, the vertically polarised light after passing through A will have a component parallel to B. This component will pass through B. The resultant light will then be polarised parallel to B. Then when it reaches C, the horizontal component of the light will pass through C. Final intensity is non-zero.</p>
16	C	$\lambda = ax / D$ $x_1 = \frac{\lambda_1(D)}{a} \quad x_2 = \frac{\lambda_2(D)}{a}$ <p>For them to coincide,</p> $n_1 \lambda_1 = n_2 \lambda_2$ <p>where n is the order of the bright fringes</p> <p>Ratio of $n_1 / n_2 = 900 / 750$</p> <p>The smallest n_1 such that both n_1 and n_2 are integers is 6.</p> <p>Therefore,</p> <p>Smallest distance is $6x_1 = 6 (750 \times 10^{-9})(2.0) / (2.0 \times 10^{-3})$</p> $= 4.5 \times 10^{-3} \text{ m}$
17	B	Coherence = constant phase difference.
18	A	<p>Option A : $v = f\lambda$</p> <p>By increasing v, λ will be larger, f being constant. The larger λ will be more comparable to the slit width and hence the diffraction will be more significant.</p> <p>Incorrect answers</p> <p>Option B: Increasing the f will reduce the λ, v being constant.</p> <p>Option C & D: It will not change anything</p>
19	C	$R = \rho L / A$ $A = \rho L / R \text{ --- (1)}$ $D = M / V = M / LA$ $\Rightarrow M = DLA \text{ --- (2)}$ <p>Substitute (1) into (2):</p> $M = D\rho L^2 / R$ <p>$M \propto D \rho$ (L & R = constant)</p> $M_C / M_A = (D_C / D_A) \times (\rho_C / \rho_A)$ $M_C / M_A = (3D_A / D_A) \times (0.5 \rho_A / \rho_A)$ $= 3 \times 0.5$ $= 1.50$

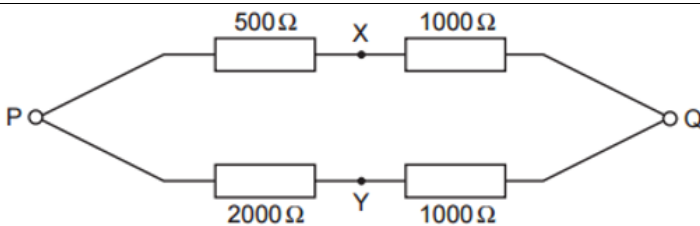
20	C	$P_1 = I^2 R \text{ --- (1)}$ $P_2 = E I = (V + I r) I$ $= V I + I^2 r$ $= (I R) I + I^2 r$ $= I^2 (R + r) \text{ --- (2)}$ $(1)/(2): P_1/P_2 = R/(R + r) = 4.8/(4.8 + 1.2) = 0.80$
21	A	<p>P.d across variable resistor ($R=0$) = 0 V</p> <p>P.d across variable resistor ($R= 4$) = $(4/4+6)(6) = 2.4$ V</p>
22	D	<p>Suppose each bulb resistance is R.</p> <p>The initial combined resistance is $R/3$.</p> <p>Current through each bulb is E/R, ammeter reading is $3(E/R)$</p> <p>Power of each bulb is E^2/R</p> <p>After one bulb breaks,</p> <p>The combined resistance is $R/2$.</p> <p>Current through each bulb is E/R, ammeter reading is $2(E/R)$</p> <p>Power of each bulb is E^2/R</p>
23	B	 <p>Using potential divider rule,</p> $V_{xp} = (500/1500) (6) = 2 \text{ V}$ $V_{yp} = (2000/3000) (6) = 4 \text{ V}$ $V_{xy} = 4 - 2 = 2 \text{ V}$
24	D	<p>Using FLHR, the force is out of the plane</p> $F = (B/2)IL \cos 30^\circ = 4.0 \cos 30^\circ = 3.5 \text{ mN}$
25	A	<p>Consider any one point on Q, the B-field due to P is in anti-clockwise direction.</p> <p>B_p is always anti-parallel to current of Q.</p>
26	B	<p>Since wavelength remains the same, photon energy remains constant and KE remains constant.</p> <p>Rate of incidence photons increases and rate of emission of electrons increases.</p>

27	C	<p>Using photoelectric equation, $hf = \phi + eV_s$</p> <p>Rearranging the equation gives $V_s = \frac{hf}{e} - \frac{\phi}{e}$</p> <p>Hence a graph of V_s against f will give a straight line where the gradient is $\frac{h}{e}$</p> <p>x-intercept = $\frac{\phi}{e}$</p>
28	D	<p>Let $KE = E = \frac{p^2}{2m}$</p> <p>KE of x = $E = \frac{p_x^2}{2m}$</p> <p>KE of y = $2E = \frac{p_y^2}{2m}$</p> <p>$\frac{p_x}{p_y} = \frac{1}{\sqrt{2}}$</p> <p>Since $\lambda = \frac{h}{p}$, hence $\frac{\lambda_y}{\lambda_x} = \frac{p_x}{p_y}$</p> <p>Hence $\lambda_y = \frac{1}{\sqrt{2}}\lambda$</p>
29	B	<p>Point A : Dark background with coloured lines, Emission spectrum</p> <p>Point B : coloured background with dark lines, Absorption</p>
30	B	<p>E_3 to E_1 is blue</p> <p>ROYGBIV</p> <p>Violet line, the energy difference must be greater than blue, hence only E_4 to E_1 is possible.</p>

Candidate's name

CTG

YISHUN JUNIOR COLLEGE JC 2 PRELIMINARY EXAMINATIONS 2017

PHYSICS HIGHER 1

8866/2
25th August 2017
2 hours

Paper 2 Structured Questions

Candidates answer on the Question Paper.
No Additional Materials are required.



READ THESE INSTRUCTIONS FIRST

Write your name and CTG in the spaces provided on this cover page.

Write in dark blue or black pen on both sides of the paper. You may use a soft pencil for any diagrams, graphs or rough working.

Do not use staples, paper clips, highlighters, glue or correction fluid.

Section A

Answer **all** questions.

Section B

Answer any **two** questions.

Write your answers in the spaces provided on the question paper.

For numerical answers, **all** working should be shown clearly.

The number of marks is given in brackets [] at the end of each question or part question.

For Examiner's Use	
Paper 1 (27.3%)	
/30	
Paper 2 (72.7%)	
Section A	
1	/5
2	/10
3	/4
4	/8
5	/8
6	/5
Section B	
7	/20
8	/20
9	/20
Penalty	
/ 80	
Overall Percentage (%)	

Data

speed of light in free space,	$c = 3.00 \times 10^8 \text{ m s}^{-1}$
elementary charge,	$e = 1.60 \times 10^{-19} \text{ C}$
the Planck constant,	$h = 6.63 \times 10^{-34} \text{ J s}$
unified atomic mass constant,	$u = 1.66 \times 10^{-27} \text{ kg}$
rest mass of electron,	$m_e = 9.11 \times 10^{-31} \text{ kg}$
rest mass of proton,	$m_p = 1.67 \times 10^{-27} \text{ kg}$
Acceleration of free fall	$g = 9.81 \text{ m s}^{-2}$

Formulae

uniformly accelerated motion,	$s = ut + \frac{1}{2}at^2$
	$v^2 = u^2 + 2as$
work done on/by a gas,	$W = p\Delta V$
hydrostatic pressure,	$p = \rho g h$
resistors in series,	$R = R_1 + R_2 + \dots$
Resistors in parallel,	$\frac{1}{R} = \frac{1}{R_1} + \frac{1}{R_2} + \dots$

Section A

Answer **all** the questions in the spaces provided.

- 1 (a) The density of the material of a rectangular block was determined by measuring the mass and linear dimensions of the block. The table shows the results obtained, together with their absolute uncertainties.

- mass = (25.0 ± 0.1) g
- length = (5.00 ± 0.01) cm
- breadth = (2.00 ± 0.01) cm
- height = (1.00 ± 0.01) cm

Express the density of the block ρ , with its associated absolute uncertainty of $\Delta\rho$.

$$\Delta\rho = \dots\dots\dots \pm \dots\dots\dots \text{ g cm}^{-3} \quad [4]$$

- (b) Estimate the kinetic energy of a typical car cruising along the expressway in Singapore.

$$\text{kinetic energy} = \dots\dots\dots \text{ J} \quad [1]$$

- 2 A stone is projected with a speed of 5.0 m s^{-1} from a cliff on a faraway planet. It travels from point A, through point B and to point D as shown in Fig. 2.1.

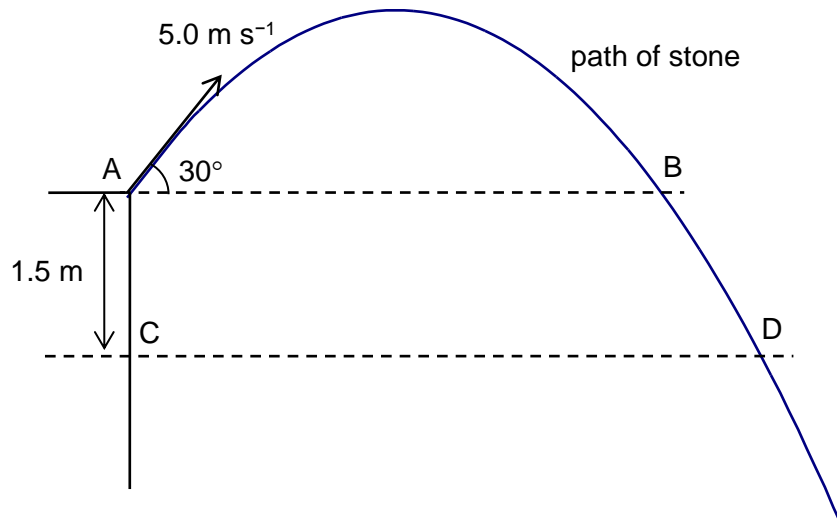

Fig. 2.1

Fig. 2.2 shows the variation of the stone's vertical velocity v with time t .

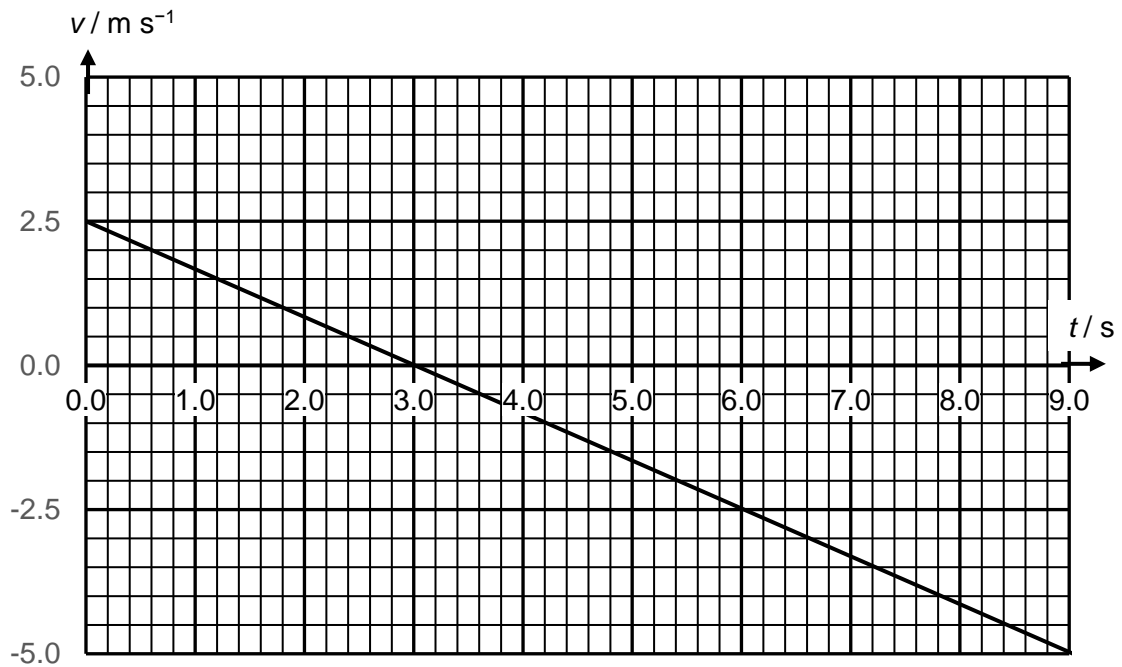

Fig. 2.2

- (a) Determine the acceleration in the vertical direction.

acceleration = m s⁻² [1]

- (b) Determine the vertical velocity of the stone at point D.

speed = m s⁻¹ [2]

- (c) Shade on Fig. 2.2, the area corresponding to the vertical displacement between point B and D. [2]

- (d) Mark on the line with 'X' in Fig. 2.2, the instant when the stone is moving 45° to the horizontal axis. Explain how you derived your answer clearly in the space provided below.

[3]

- (e) Sketch in Fig. 2.2, the variation of the stone's vertical velocity with time when the effect of air resistance is not negligible. [2]

- 3 A 60 kg skier starts from rest at A and glides down a smooth slope. The dimensions of the slope and the skier's motion are illustrated in Fig. 3.1. The skier passes through point B before launching himself off the cliff at point C.

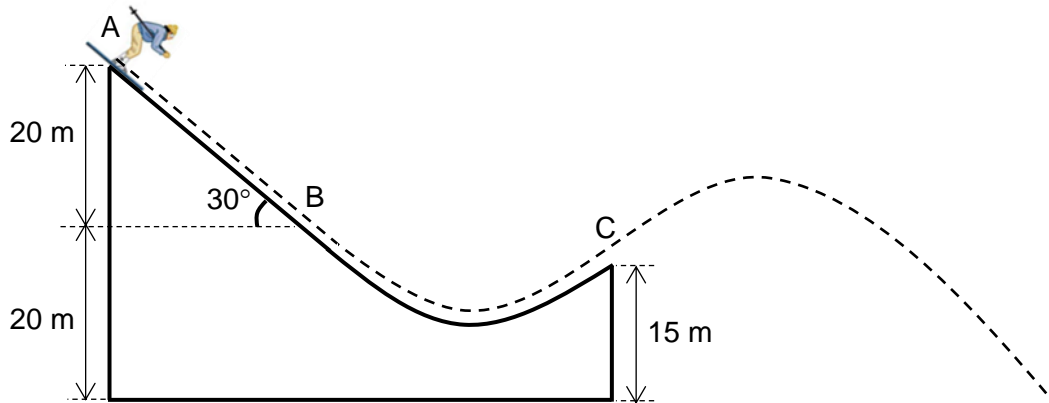

Fig. 3.1

- (a) Determine the work done by the weight of the skier from point A to B.

work done = J [2]

- (b) Determine the speed of the skier at point C.

speed = m s^{-1} [2]

- 4 (a) The I - V characteristic graph of a given tungsten filament lamp is shown in Fig. 4.1.

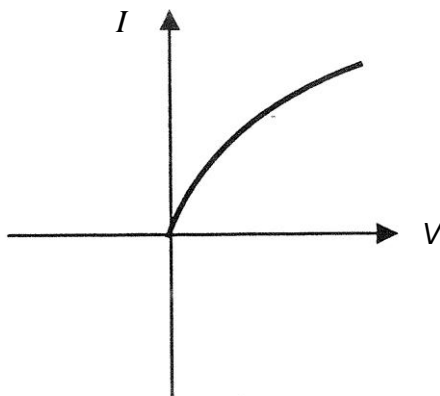

Fig. 4.1

With the aid of a labelled diagram, describe how the I - V characteristic graph can be obtained.

.....

.....

.....

.....

.....

[4]

- (b) A high potential difference is applied between the electrodes of a gas discharge tube so that the gas is ionised (both electrons and positive charged particles are present). The gas carries a current of 8.16 mA and the number of electrons passing any point in the gas per unit time is $2.58 \times 10^{16} \text{ s}^{-1}$.

- (i) Calculate the current due to the electrons.

current =A [2]

- (ii) If the charge on each positively charged particle is $3.2 \times 10^{-19} \text{ C}$, what is the number of positively charged particles passing any point in the gas per unit time?

number per unit time = s^{-1} [2]

- 5 A photocell may be used to demonstrate the photoelectric effect. Fig. 5.1 shows a photocell connected to a circuit.

The photocell consists of two metal plates E and C. The metal plate E is sensitive to electromagnetic radiation. The metal plate C is a collector plate. A sensitive ammeter measures the photoelectric current.

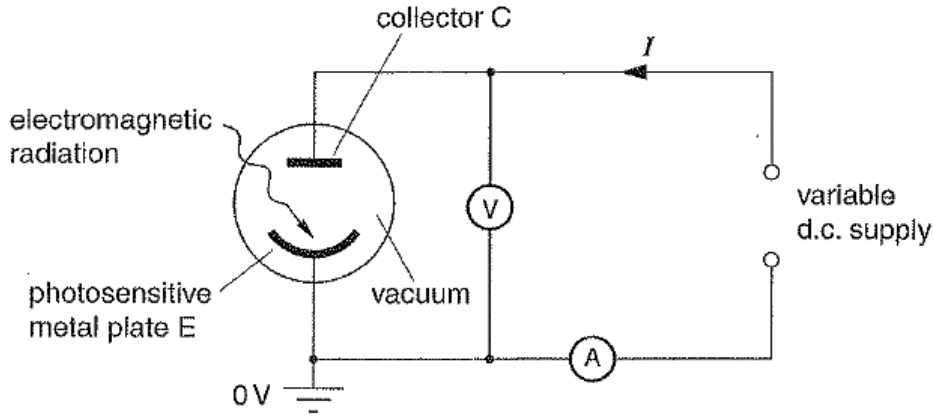

Fig. 5.1

Fig. 5.2 shows the variation with potential difference V of the photoelectric current I for radiation of a particular intensity.

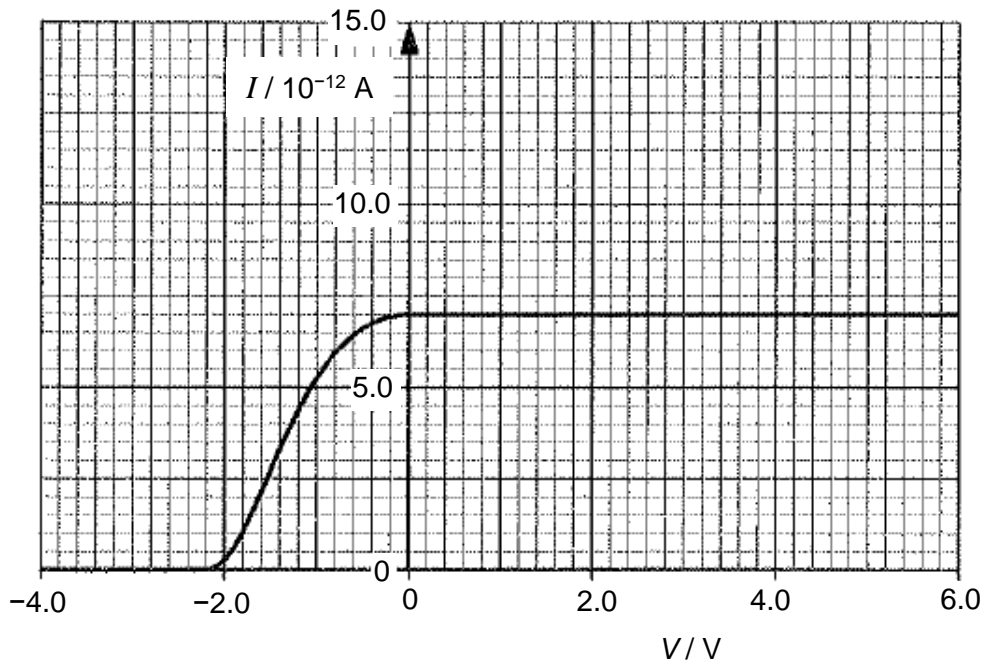

Fig. 5.2

- (a) Explain what is meant by *photoelectric effect*.

.....

.....

.....

[2]

- (b) Explain why the photoelectric current decreases and eventually becomes zero when the potential difference becomes negative.

.....

[2]

- (c) Use Fig. 5.2 to show that the maximum speed of the photoelectrons is $8.8 \times 10^5 \text{ m s}^{-1}$.

[2]

- (d) The intensity of the electromagnetic radiation is doubled but the frequency is kept constant. On Fig. 5.2, sketch a graph to show the new I - V characteristic.

- 6 In Fig. 6.1, a fluorescent tube is filled with mercury vapour at low pressure. After mercury atoms have been excited they emit photons. The emitted photons have energy corresponding to ultra-violet in the electromagnetic spectrum.

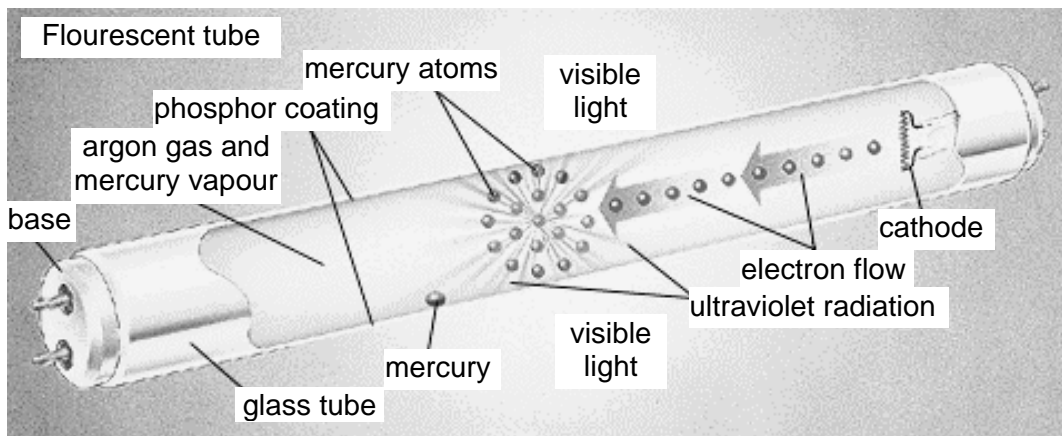

Fig. 6.1

Explain

(a) what is meant by an *excited* mercury atom;

.....
..... [1]

(b) how the mercury atoms in the fluorescent tube become excited;

.....
..... [1]

(c) why the excited mercury atoms emit photons of specific frequencies; and

.....
.....
.....
.....
..... [2]

(d) how the phosphor coating on the inside of a fluorescent tube emits visible light.

.....
..... [1]

Section B

Answer any **two** questions from this section in the spaces provided.

- 7 (a) Explain what is meant by *progressive wave*.

.....

 [2]

- (b) To study the attenuation of radio wave signal by air, a radio wave detector is placed at a distance x away from a radio wave point source. The intensity I is noted at different distances and variation of I with x is shown in Fig. 7.1.

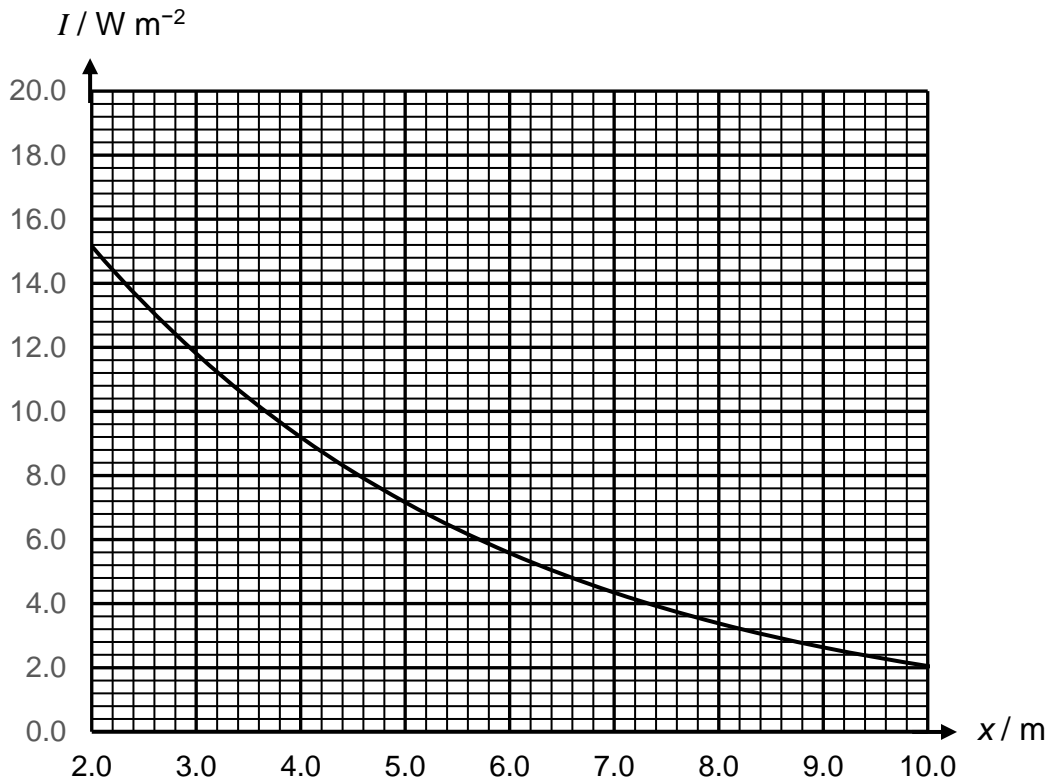

Fig. 7.1

Using Fig. 7.1,

- (i) describe how the intensity I varies with the distance x ,

.....

 [2]

(ii) determine the ratio

$$\frac{\text{amplitude at } x = 4.0 \text{ m}}{\text{amplitude at } x = 7.0 \text{ m}}$$

ratio = [3]

(c) The shape of the curve in Fig. 7.1 suggests that the decrease of the intensity I with range in air x could be exponential. A graph of $\ln(I / W m^{-2})$ against x is plotted to test the relationship as shown in Fig. 7.2.

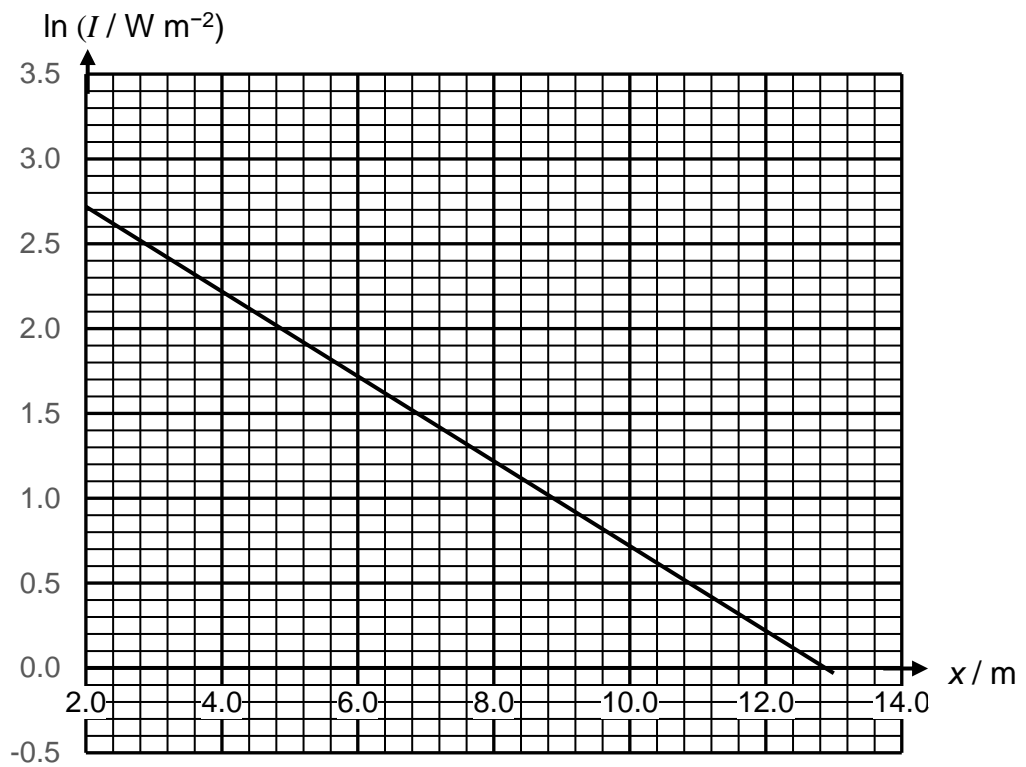

Fig. 7.2

- (i) Determine the gradient of the graph in Fig. 7.2.

gradient = [1]

- (ii) It is suggested that the exponential relationship between I and x is in the form

$$I = I_0 e^{-kx}$$

where I_0 is the intensity at $x = 0$ and k is a constant.

Using Fig. 7.2, explain whether the above exponential relationship is true.

.....

 [2]

- (d) A string, tied to a sinusoidal oscillator at P and running over a support at Q, is stretched by a block of mass m as shown in Fig. 7.3. The amplitude of the motion at P is small enough for that point to be considered a node. A node also exists at Q.



Fig. 7.3

- (i) Explain how stationary waves are formed along the string.

.....

 [2]

(ii) In terms of phase change, explain why a node is formed at Q.

.....

 [2]

(iii) The frequency of the oscillator is set at 120 Hz. A stationary wave is formed when the length L is 1.20 m. The maximum amplitude of the antinode is 0.80 cm. The length is slowly increased and the stationary wave disappears. The stationary wave is again formed when L is increased by 0.30 m.

1. Determine the velocity of the wave in the string.

velocity = m s⁻¹ [2]

2. Point X is at one of the antinodes when L is 1.50 m. Point Y is at a distance $\lambda/8$ away from point X, where λ is the wavelength of the wave. Determine the phase difference between the two points.

phase difference = rad [1]

- (e) A signal from source S is emitted through two separate speakers as shown in Fig. 7.4.

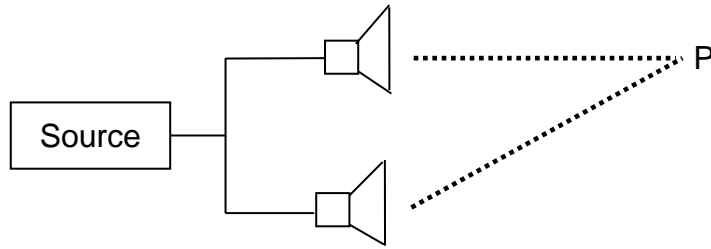

Fig. 7.4

The sound waves from the speakers reach a point P by two paths which differ in length by 1.4 m. When the frequency of the sound is gradually increased, the resultant intensity at P goes through a series of maxima and minima. A maximum occurs when the frequency is 1000 Hz and the next maximum occurs at 1200 Hz.

Determine the speed of the sound wave.

speed of sound wave = m s⁻¹ [3]

- 8 (a) Explain what is meant by *electromotive force of a source* and *potential difference between two points of a circuit*.

.....

.....

.....

.....

.....

..... [2]

- (b) The circuit in Fig. 8.1 consists of three fixed resistors, each of which has a safe power rating of 0.80 W.

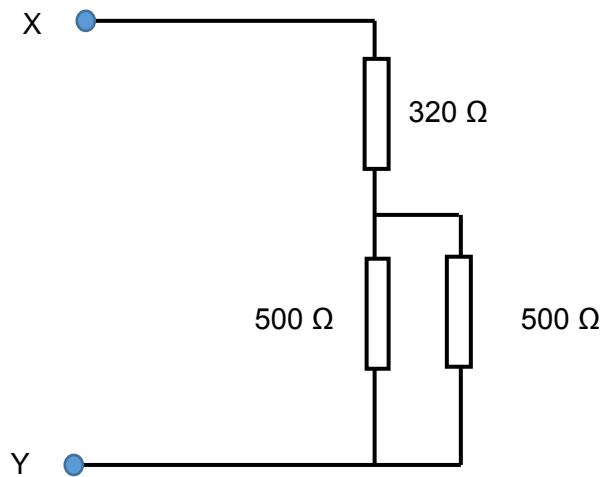

Fig. 8.1

Determine the maximum potential difference that can be applied between X and Y without damage to any of the resistor.

maximum potential difference =V [4]

- (c) A car battery is used to power up four lamps as shown in Fig. 6.2. The resistance of each lamp should be $180\ \Omega$ when it is working under normal conditions.

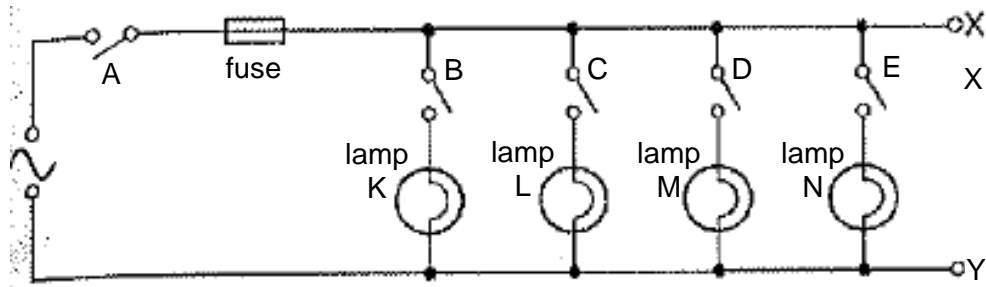

Fig. 8.2

A fault is discovered in the circuit, so switch A is open and the fuse is removed for safety. An electrician uses a resistance meter, an equipment which can be used to measure the effective resistance across any two points in a circuit, to check the lamps. He connected the resistance meter between the points X and Y and the readings obtained for different switch positions are shown in Fig. 8.3.

Switches					Resistance meter reading/ Ω
A	B	C	D	E	
open	open	open	open	open	14 000 000
open	open	open	open	closed	180
open	open	open	closed	closed	90
open	open	closed	closed	closed	60
open	closed	closed	closed	closed	0.2

Fig. 8.3

- (i) Based on the readings in Fig. 8.3, explain which lamp is faulty in the circuit. Show your workings clearly.

faulty lamp = [2]

(ii) Suggest what could have happened to the faulty lamp.

.....
..... [1]

(iii) Suggest why there is still a reading of 14 MΩ on the resistance meter when all the switches are open.

.....
.....
..... [1]

(d) A simple D.C. motor works on the principle of converting electrical energy to mechanical energy in the form of rotation.

A small rectangular coil ABCD contains 150 turns of wire. The sides AB and BC of the coil are lengths of 4.5 cm and 2.8 cm respectively, as shown in Fig. 8.4

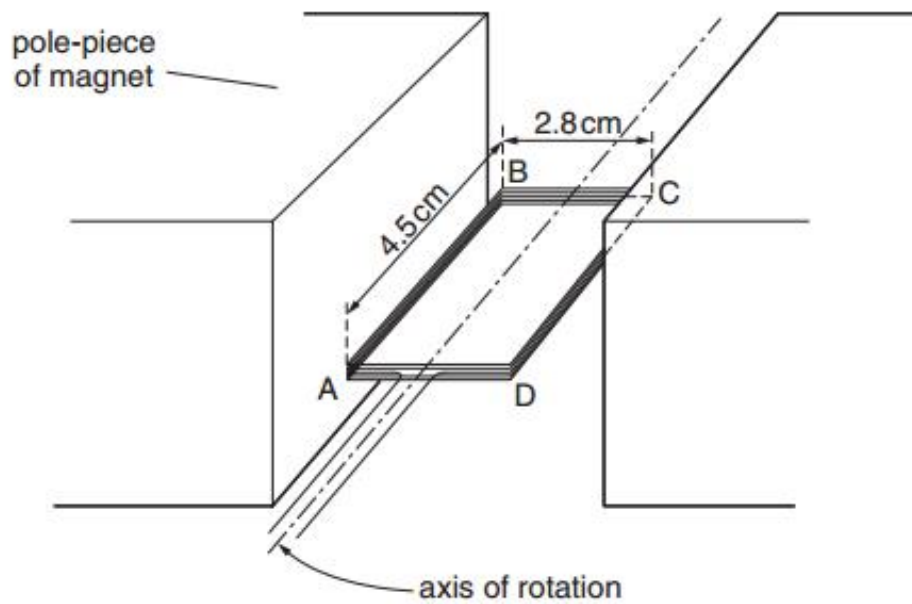

Fig. 8.4

The coil is held between the poles of a large magnet so that the coil can rotate about an axis through its centre.

The magnet produces a uniform magnetic field of flux density B between its poles. When a current of 185 mA is passed through the coils, it causes the coil to rotate.

(i) Define magnetic flux density.

.....
.....
..... [1]

(ii) For the coil to achieve maximum torque, state whether the plane of the coil should be parallel to, or normal to, the direction of magnetic field.

..... [1]

(iii) For the coil in the position shown in Fig. 8.4, the torque produced in the coil is 2.1×10^{-3} Nm.

Calculate the magnitude of the force on

1. side AB of the coil,

force on AB =N [2]

2. side BC of the coil.

force on BC =N [1]

(iv) Use your answer to (iii) to show that the magnetic flux density B between the poles of the magnet is 60 mT.

[2]

- (v) As the coil rotates and make one complete revolution, sketch the variation of magnetic force acting on side BC with angle of rotation. (values are not required)

The angle of rotation for the coil in the position shown in Fig. 8.4 is taken to be 0° .

magnetic force on BC / N

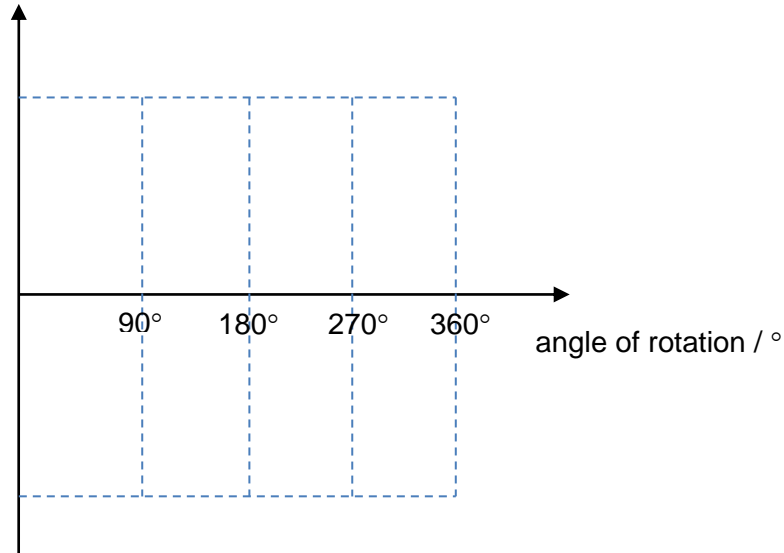

[1]

- (vi) Show by means of a simple diagram, the relative directions of magnetic force F , magnetic flux density B and current I when the angle of rotation θ is 30° . You may make your own assumption on the current direction and direction of rotation.

[2]

9 (a) State the principle of conservation of momentum.

.....
.....
..... [2]

(b) A 0.0200 kg object travelling towards the right at 8.0 m s⁻¹ collides head on with another 0.0100 kg object travelling towards the right at 5.0 m s⁻¹. After collision, the 0.0200 kg object travels towards the left at 2.0 m s⁻¹.

(i) Calculate the speed of the 0.0100 kg object after collision.

speed = m s⁻¹ [2]

(ii) State the direction of motion of the 0.0100 kg object after collision.

..... [1]

(iii) If the impact time is 0.120 s, calculate the average force exerted on the 0.0100 kg object by the 0.0200 kg object during collision.

force = N [2]

(iv) Explain why it is not possible for both objects to stop at the same instant during the collision.

.....
.....
.....
..... [2]

- (c) Fig. 9.1 shows a wooden block B (mass = 3.0 kg) resting on another block A (mass = 5.0 kg). Both blocks are connected by a light string which goes around a fixed smooth pulley. The friction between block A and block B is 12 N. Block A is travelling at constant velocity under an applied force of 40 N along a horizontal rough ground.

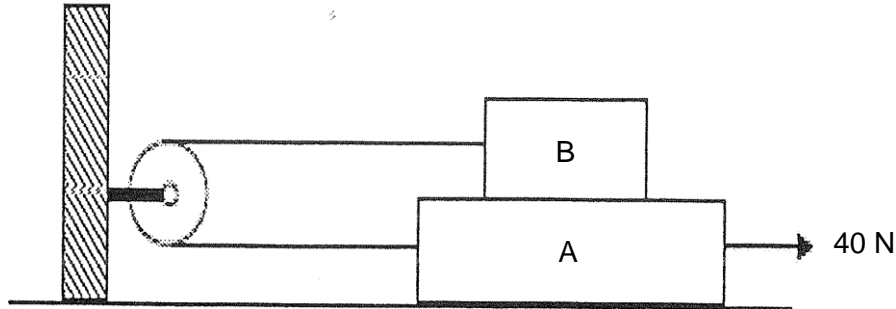

Fig. 9.1

- (i) Draw a free body diagram of block A. (Name all the forces)



[3]

- (ii) Draw a free body diagram of block B. (Name all the forces)



[2]

- (iii) With reference to your answer in (ii), calculate the force exerted on block B by the string.

force exerted on block B by string = N [1]

- (iv) Hence, or otherwise, calculate the force exerted on block A by the ground.

force exerted on block A by ground = N [3]

- (v) Describe the subsequent motion of block B if the string suddenly snaps, given that block B remains in contact with block A at all times.

.....
.....
.....
.....

[2]

--- End of paper ---

2017 8866 JC2 H1 Physics Prelim Paper 2 Solutions

1	(a)	$\rho = M/V = M/(LBH) = 25.0/(5.0)(2.0)(1.0) = 2.50 \text{ g cm}^{-3}$ $\Delta\rho/\rho = \Delta M/M + \Delta L/L + \Delta B/B + \Delta H/H$ $\Delta\rho/2.50 = 0.1/25.0 + 0.01/5.00 + 0.01/2.00 + 0.01/1.00$ $\Delta\rho = 0.0525 \text{ g cm}^{-3}$ $\Delta\rho = 0.05 \text{ g cm}^{-3} \text{ or } 0.06 \text{ g cm}^{-3} \text{ (1 sf)}$ $\rho = (2.50 \pm 0.05 \text{ or } 0.06) \text{ g cm}^{-3}$	<p>B1</p> <p>C1</p> <p>A1</p> <p>A1</p>
		Marker's comment	
	(b)	Speed must be between 70 km h^{-1} and 100 km h^{-1} . Mass of car is between 1000 kg to 2000 kg .	A1
		Marker's comment	
2	(a)	acceleration = gradient of the graph $= \frac{-2.5 - 2.5}{6.0 - 0}$ $= -0.83 \text{ m s}^{-2}$	1
		Marker's comment	
	(b)	$v^2 = u^2 + 2as$ $= [5.0 (\sin 30)]^2 + 2 (-0.83)(-1.5)$ $v = 2.96 \text{ m s}^{-1}$	<p>1</p> <p>1</p>
		Marker's comment	
	(c)	The area between $t = 6.02 \text{ s}$ to point where $v =$ calculated value of (b) 1 mark for correct starting time 1 mark for the ending time which corresponds to value of (b)	<p>1</p> <p>1</p>
		Marker's comment	
	(d)	$5.0 \cos 30 = 4.33 \text{ m s}^{-1}$ For the velocity to be 45° to the horizontal, the vertical velocity must also be 4.33 m s^{-1} (t will be at 8.2 s)	1
		Marker's comment	

	<p>(e)</p> <p>Correct curvature [1] Need not reach terminal velocity Max height is reached at a shorter time [1]</p>	<p>1 1</p>
<p>3</p>	<p>(a) $WD = F s$ $= 60 (9.81) (20) \quad [1]$ $= 1.18 \times 10^4 \text{ J} \quad [1]$</p>	<p>1 1</p>
	<p>Marker's comment</p>	
	<p>(b) By conservation of energy Loss in GPE = Gain in KE $mg(40 - 15) = \frac{1}{2} m v^2 \quad [1]$ $9.81 (25) = \frac{1}{2} v^2$ $v = 22.1 \text{ m s}^{-1} \quad [1]$</p>	<p>1 1</p>
	<p>Marker's comment</p>	
<p>4</p>	<p>Diagram: <u>Cell, Variable Resistor, Filament Lamp</u> connected <u>in series</u> + <u>Ammeter</u> connected <u>in series</u> to <u>Filament Lamp</u> <u>Voltmeter</u> connected <u>in parallel</u> to <u>Filament Lamp</u> <u>Correct Circuit Diagram Symbols</u></p> <p>Procedures: By <u>adjusting resistance of variable resistor</u> to a <u>specific value R</u>, the <u>current I</u> flowing through filament lamp can be obtained from <u>ammeter</u>.</p> <p>The corresponding <u>potential difference</u> across filament lamp V can be obtained from <u>voltmeter</u>.</p> <p><u>Decrease</u> or <u>increase R</u> to obtain <u>another 7 sets of (V, I)</u>. <u>Plot the I-V characteristic graph</u> using the 8 sets of (V, I) and <u>draw a best fit curve</u>.</p>	<p>B1 B1 B1 B1</p>
	<p>Marker's comment</p>	

	(b)	$I_1 = Q_1/t$ $= [(N_1)/t] \times e$ $= (2.58 \times 10^{16}) (1.60 \times 10^{-19})$ $= 4.13 \times 10^{-3} \text{ A}$	M0 C1 A1
		Marker's comment	
	(c)	$I_T = I_1 + I_2$ $Q_2/t = I_T - I_1$ $[(N_2)/t] \times p = I_T - I_1$ $N_2/t = (I_T - I_1)/p$ $= \{(8.16 - 4.13) \times 10^{-3}\}/(3.2 \times 10^{-19})$ $= 1.26 \times 10^{16} \text{ s}^{-1}$	M0 C1 A1
		Marker's comment	
5	(a)	The <i>photoelectric effect</i> is the <u>emission of electrons from the surface of a metal</u> when electromagnetic radiation of <u>high enough frequency</u> is incident on it.	1 1
		Marker's comment	
	(b)	When the potential of plate C is negative, photoelectrons emitted are repelled. As the potential becomes more negative, less photoelectrons are able to reach the collector. Current will be zero when the negative potential is large enough to stop the fastest moving electron.	1 1
		Marker's comment	
	(c)	From graph, stopping potential $V_s = 2.2 \text{ V}$ $eVs = \frac{1}{2} m v_{\max}^2$ $v_{\max}^2 = 2eV_s/m_e$ $v_{\max} = \sqrt{\frac{2(1.6 \times 10^{-19})(2.2)}{9.11 \times 10^{-31}}} = 8.79 \times 10^5 \text{ m s}^{-1}$	1 1
		Marker's comment	
	(e)	Same stopping potential, Max photocurrent at $7.0 \times 2 = 14$	2
		Marker's comment	
6	(a)	Electron/atom (in ground state) has transited/ moved/ jumped to a higher energy level by either absorbing an photon or colliding with another atom.	1

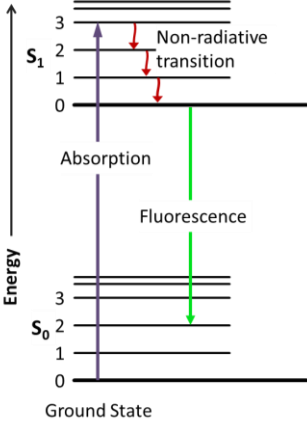
		Marker's comment	
	(b)	Free electrons collide with (orbital electrons) mercury atom, hence transferring energy	1
		Marker's comment	
	(c)	(mercury) atoms have discrete/ specific energy levels. When electrons transit/change levels, they lose an exact/specific/discrete set of energy equal to energy difference between the two levels, leading to photons of discrete/specific energy and hence specific wavelengths/frequency.	1 1
		Marker's comment	
	(d)	The coating <u>absorbs</u> photons/ UV light and re-emits photons of lower energy /longer wavelength/lower frequency.	1
		 <div style="border: 1px solid black; padding: 10px; margin-left: 20px;"> <p>Additional information:</p> <p>After an electron absorbs a high energy photon the system is excited electronically and vibrationally. The system relaxes vibrationally (non-radiative transition), and eventually fluoresces at a longer wavelength.</p> <p>Source: fluorescence - wikipedia</p> </div>	
		Marker's comment	

Section B (Option Questions)

7	(a)	A wave is progressive when the wavefront moves [1] and energy is dissipated to the surrounding [1] along the direction of propagation.	1 1
		Marker's comment	
	(b)	(i) The intensity decreases [1] at a decreasing rate [1] as x increases.	1 1
		Marker's comment	
		(ii) $\frac{\text{intensity at } x = 4.0 \text{ m}}{\text{intensity at } x = 7.0 \text{ m}} = \frac{9.2}{4.4}$ [1 mark for reading off correctly]	1

		$I \propto A^2$ [1 mark for showing this relationship]	1
		Ratio of amplitude = $(9.2/4.4)^{0.5}$ = 1.44 [1 mark for final answer]	1
Marker's comment			
(c)	(i)	Gradient = $\frac{0 - 2.7}{12.8 - 2} = -0.25$	1
Marker's comment			
(c)	(ii)	$I = I_0 e^{-kx}$ $\ln I = -kx + \ln I_0$ [1 mark for showing the linearization] Since the graph in Fig 7.2 is a straight line [1] with a non-zero y-intercept, the relationship is correct [no mark for making conclusion without any explanation]	1 1
Marker's comment			
(d)	(i)	Formed due to superposition/interference of the incident wave from oscillator and reflected wave from Q. [1] The two waves have the same speed, wavelength/frequency, same amplitude and travel in opposite directions [1]	1 1
Marker's comment			
	(ii)	There is a $180^\circ / \pi$ radian phase change at Q [1] since it is a fixed end, Hence there is destructive interference between the incident and reflected wave, [1] since they are π radian out of phase. – this mark given only if they are able to explain about the phase change.	1 1
Marker's comment			
	(iii)	1. $\frac{1}{2} \lambda = 0.30 \text{ m}$ $\lambda = 0.60 \text{ m}$ [1] $v = f \lambda$ = 120 (0.60) = 72 m s ⁻¹ [1]	1 1
Marker's comment			

		2.	Phase different is zero.	1
		Marker's comment		
	(e)		<p>For constructive interference, Path difference = 1.4 m (fixed) $n\lambda = 1.4$ $n\left(\frac{v}{f_1}\right) = 1.4 \Rightarrow n\left(\frac{v}{1000}\right) = 1.4 \Rightarrow n = \frac{1400}{v} \quad \text{-- (1)}$ $(n + 1)\left(\frac{v}{f_2}\right) = 1.4 \Rightarrow (n + 1)\left(\frac{v}{1200}\right) = 1.4 \quad \text{-- (2)}$</p> <p>Solving (1) and (2), $v = 280 \text{ m s}^{-1}$</p>	1 1 1
		Marker's comment		

8	(a)		<p>Potential difference between two points of a circuit is the amount of electrical energy converted per unit charge into other forms of energy when the charge moved from one point to the other.</p> <p>Electromotive force of a source is defined as the energy converted per unit charge from other forms of energy into electrical energy when the charge is driven through the source round a complete circuit.</p>	1 1
		Marker's comment		
	(b)		<p>Calculate safe maximum current</p> <p>500Ω : current = $\sqrt{\frac{P}{R}} = \sqrt{\frac{0.8}{500}} = 0.040 \text{ A}$</p> <p>$2 \times 0.040 = 0.080 \text{ A}$</p> <p>$320 \Omega$: current = $\sqrt{\frac{0.8}{320}} = 0.050 \text{ A}$</p> <p>2 marks for calculating max current for both types of resistors.</p> <p>The 320Ω resistor will be damaged first.</p> <p>Maximum current in circuit = 0.050 A</p> <p>1 mark for recognizing the maximum current or the resistor which will be damaged first.</p> <p>Maximum safe p.d = $0.050 (320 + 250) = 28.5 \text{ V}$</p> <p>1 mark for determining the maximum safe potential difference.</p>	1 1 1 1
		Marker's comment		
	(c)	(i)	<p>Lamp K.</p> <p>When switches B, C, D, E are closed and switch A open, the reading should be 45Ω. But the reading measured is 0.2Ω.</p>	1 1

			Marker's comment	
		(ii)	The lamp is short-circuited or any other possible reason which could cause the resistance of the lamp to be reduced to near zero. Do not accept that the lamp is fused because if the lamp is fused, the resistance should be infinite (open circuit).	1
			Marker's comment	
		(iii)	The resistance meter has its own internal resistance of 1.4×10^7 when operated. (This resistance is connected in parallel to the rest of circuit. Hence when the rest of the circuit to be measured has infinite resistance, the effective resistance is its own internal resistance.) Do not accept resistance meter is non-ideal or that the resistance meter can only give a maximum reading of this value. These answers are too generic. Student should explain more clearly.	1
			Marker's comment	
	(d)	(i)	The magnetic flux density of a magnetic field is defined as the force exerted on a unit length of conductor carrying a unit current placed at right angles to the field.	1
			Marker's comment	
		(ii)	Parallel to the field	1
			Marker's comment	
		(iii)	1. Torque = Fd $2.1 \times 10^{-3} = F (2.8 \times 10^{-2})$ $F = 0.075 \text{ N}$ (no marks for using 4.5 cm)	1 1
			Marker's comment	
			2. Zero, since B field and current are parallel.	1
			Marker's comment	
		(iv)	$F = N (BIL \sin \theta)$ $0.075 = 150 (B) (0.185)(0.045)$ $B = 0.060 = 60 \text{ mT}$	1 1
			Marker's comment	
		(v)	Sine graph	1
			Marker's comment	

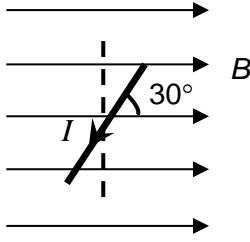
		(vi)	<p>Correct identification of direction of force (in or out of plane)</p> <p>Clear diagram with proper labeling of B field, current and angle of rotation</p> 	<p>1</p> <p>1</p>
			Marker's comment	
9	(a)		<p>The principle of conservation of momentum states that <u>total momentum</u> in a closed system <u>remains constant</u> if and only if the <u>net external forces</u> acting on the bodies <u>are zero</u>.</p>	<p>B1</p> <p>B1</p>
			Marker's comment	
	(b)	(i)	<p>Rightwards as positive:</p> $\Sigma p_i = \Sigma p_f$ $(0.0200)(8.0) + (0.0100)(5.0) = (0.0200)(-2.0) + (0.0100) v$ $v = 25 \text{ m s}^{-1}$	<p>M0</p> <p>C1</p> <p>A1</p>
			Marker's comment	
		(ii)	Rightwards	B1
		(iii)	<p>On 0.0100 kg object:</p> $\Sigma F = \Delta p / \Delta t$ $= m (v_f - v_i) / \Delta t$ $= (0.0100) [(+25) - (5.0)] / 0.120$ $= 1.67 \text{ N}$ <p>Alternatively:</p> <p>On 0.0200 kg object:</p> $\Sigma F = \Delta p / \Delta t$ $= m (v_f - v_i) / \Delta t$ $= (0.0200) [(-2) - (+8)] / 0.120$ $= -1.67 \text{ N}$ <p>By Newton's Third Law,</p> $\Sigma F \text{ on } 0.0100 \text{ kg object} = \Sigma F \text{ on } 0.0200 \text{ kg object} = 1.67 \text{ N}$	<p>M0</p> <p>C1</p> <p>A1</p> <p>M0</p> <p>C1</p> <p>A1</p>
			Marker's comment	
		(iv)	If both objects stop at the same instant, the <u>total momentum of both objects</u> is <u>zero</u> at that instant.	B1

		However, before the collision, the <u>total momentum of both objects</u> was <u>non-zero</u> . This <u>violates the principle of conservation of momentum</u> which specify that the <u>total momentum remains non-zero</u> .	B1
	(c)	(i) Normal Force (upwards), Weight of A = 5 g (downwards), Tension (leftwards), frictional force on A by B = 12 N (leftwards) and frictional force on A by ground (leftwards) and Applied Force = 40 N (rightwards) Correct Direction & Properly labelled -1 for each missing or additional or forces drawn in incorrect direction -1 for each forces not labelled properly	B2
		(ii) Normal Force (upwards), Weight of B = 3 g (downwards), Tension (leftwards) and frictional force on B by A = 12 N Correct Direction & Properly labelled -1 for each missing or additional or forces drawn in incorrect direction -1 for each forces not labelled properly	B2
		(iii) $T = f_{BA} = 12 \text{ N}$	A1
		(iv) $f_{AG} + T + f_{AB} = 40$ $f_{AG} + 12 + 12 = 40$ $f_{AG} = 16 \text{ N}$ Force by ground = $\sqrt{((3 + 5)(9.81))^2 + 16^2}$ = 80 N	C1 B1 A1
		(v) Block B will slow down (because of friction). Block B will then <u>change direction</u> and <u>accelerate</u> towards the right.	B1 B1
		Marker's comment	