

Nanyang Primary School
Continual Assessment 2006
Mathematics
Primary One

Name: _____ () Marks: / 100

Class: Primary 1 ()

Date: 24 August 2006



Duration: 1 hour 30 minutes

Section A

Questions 1 to 15 carry 2 marks each.

For each question, four choices are given. One of them is the correct answer. Choose the correct answer and write its number (1, 2, 3 or 4) in the brackets () provided.

(Total: 30 marks)

1. How many more  must you draw to make a total of 7  ?

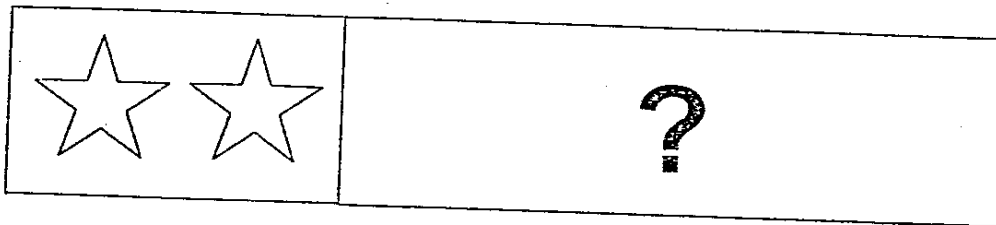

(1) 7
(3) 9

(2) 2
(4) 5

()

2.

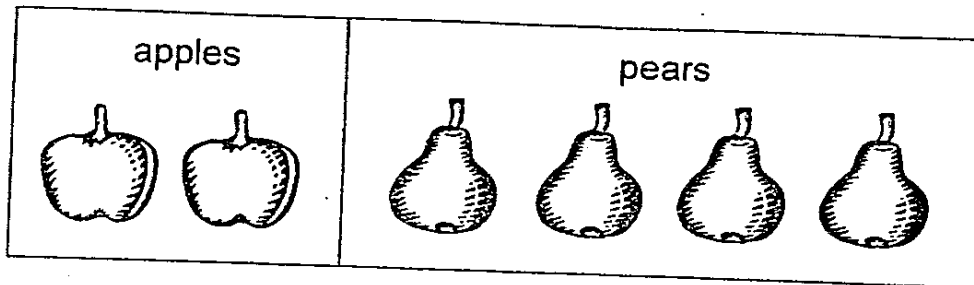

There are 2 apples and 4 pears. How many fruits are there altogether?

(1) 5

(3) 6

(2) 2

(4) 4

()

3.

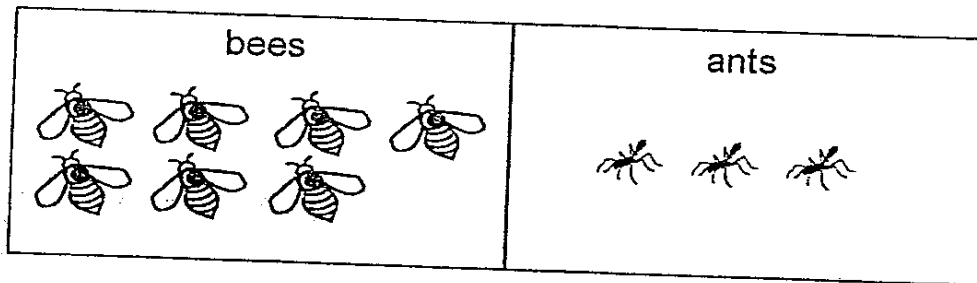

How many fewer ants than bees are there?

(1) 10

(3) 3

(2) 7

(4) 4

()

4.



The _____ egg from the right has hatched.

(1) 10th

(3) 5th

(2) 6th

(4) 4th

()

















5. What number is between 16 and 18?

- (1) 16
- (3) 18

- (2) 17
- (4) 19

()

6. Study the pattern carefully. What is the missing shape?

			
			
			
			



()

W

7. Study the diagram below.

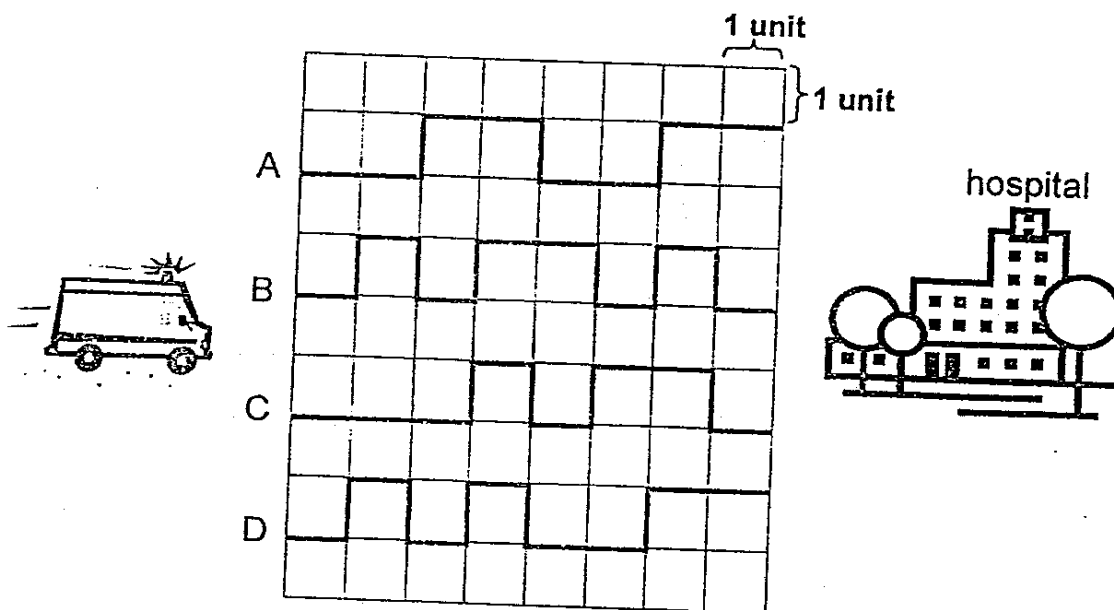

Which is the shortest route to the hospital?

- (1) A
- (3) C

- (2) B
- (4) D

()

8. Study the diagram below.

Hamburger



French fries



The mass of the hamburger is _____ heavier than the mass of the packet of French fries.

- (1) 7
- (3) 9

- (2) 2
- (4) 16

()

9. How many tens are there in 1 ten 2 ones and 9 ones?

- (1) 1
- (3) 10

- (2) 2
- (4) 11

()

10. Mr Smith sold 22 buns on Monday. He sold 20 buns on Tuesday. How many buns did he sell on both days?

- (1) 12
- (3) 32

- (2) 2
- (4) 42

()

11. 3 tens + 1 ten 8 ones = _____

- (1) 12
- (3) 40

- (2) 18
- (4) 48

()

12. What is the sum of the greatest number and the smallest number in the box?

12	29	17
21	34	

- (1) 13
- (3) 46

- (2) 22
- (4) 50

()

13.

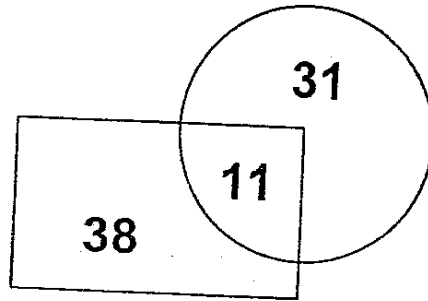

The difference between the 2 numbers in the rectangle is

- (1) 7
- (3) 27

- (2) 20
- (4) 49

()

14.

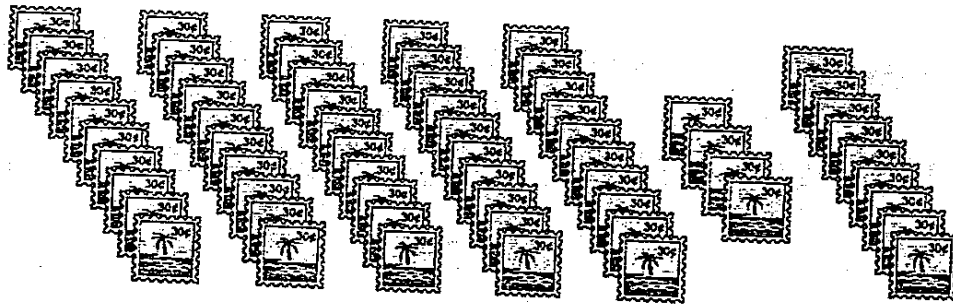

Nora had 54 stamps. His father gave her 9 more. How many stamps did she have altogether?

- (1) 45
- (3) 62

- (2) 53
- (4) 63

()

15. Study the number pattern below. What is the missing number in the triangle?

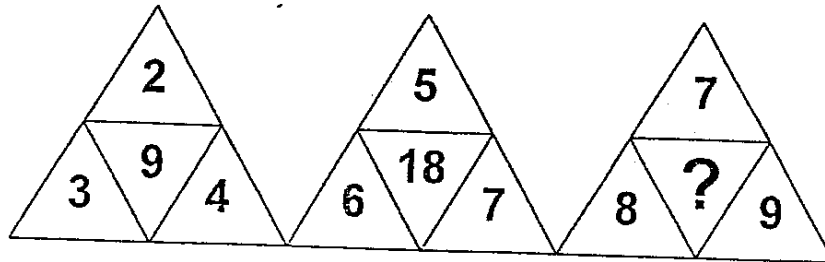

- (1) 14
(3) 25

- (2) 24
(4) 27

()

Section B

Questions 16 to 40 carry 2 marks each.
Write your answers in the spaces provided.

(Total: 50 marks)

16. Study the picture carefully and complete the number bond.

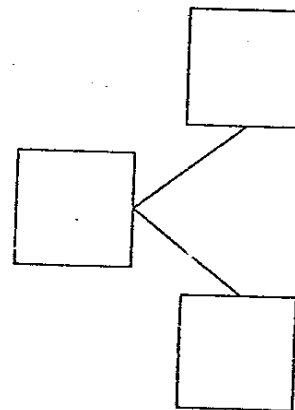
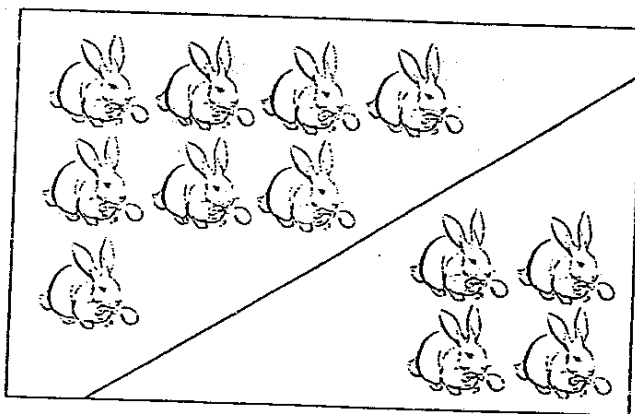

17. Mr Brown bought 8 bottles. When he reached home, he found that 2 bottles were cracked. How many bottles were not cracked?

Make a subtraction sentence in the spaces provided below.

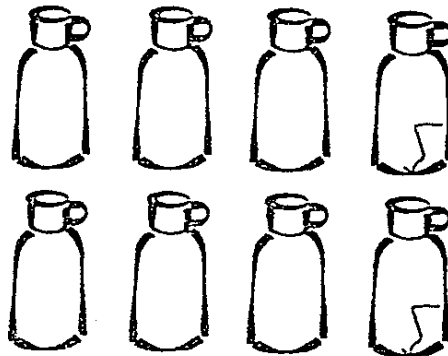

$$\square - \bigcirc = \square$$

18. Name Shape A and Shape B.

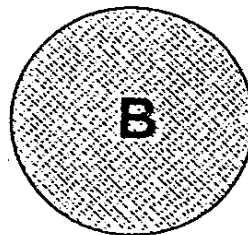
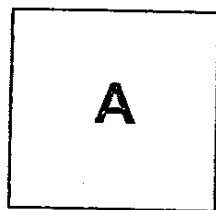

Shape A:

Shape B:

19. Write the following numerals in words.

28	
100	

20.

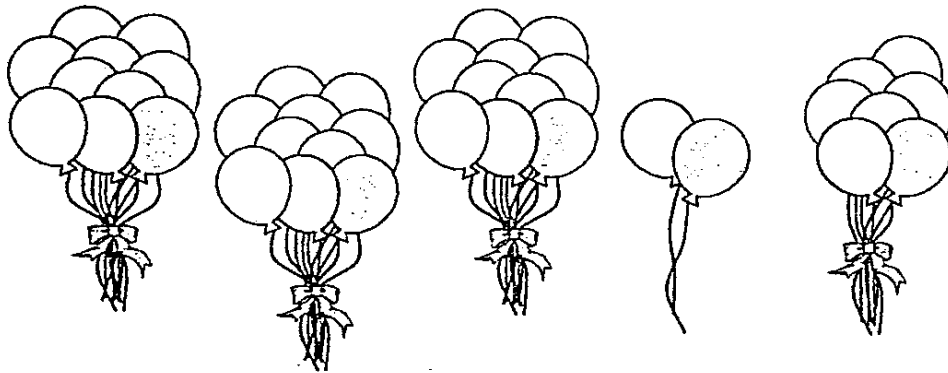

$$32 + 7 = \square$$

21. Mary had 9 sweets. She gave 3 sweets to Sumei. How many sweets had she left?

22. There were some circles on a strip of paper. Mary folded the paper. How many circles were hidden?

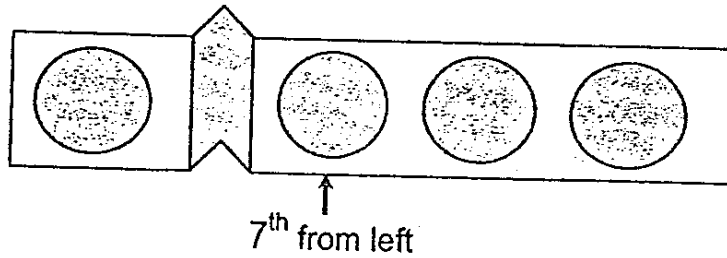

23. Colour the shape that adds up to 15.

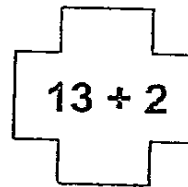
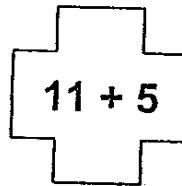
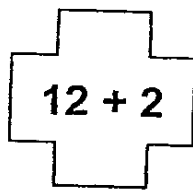

24. What number should be subtracted from 29 to make 22?

25.

$$27 - \boxed{?} = 7 + 1$$

26. Study the pattern below.

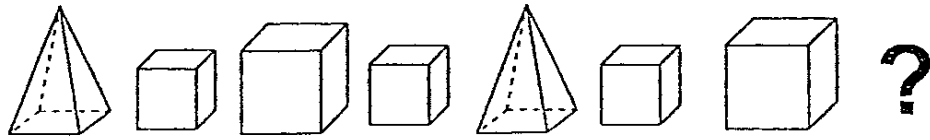

Circle the shape below that comes next in the pattern.

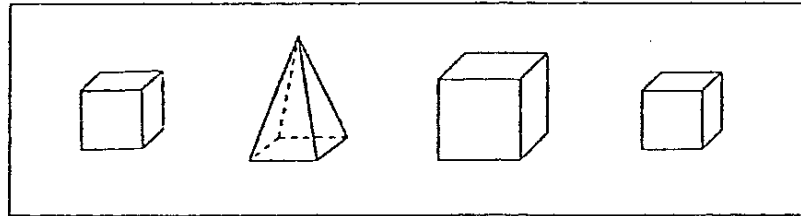

27. Colour the two shapes that form the rectangle on the left.

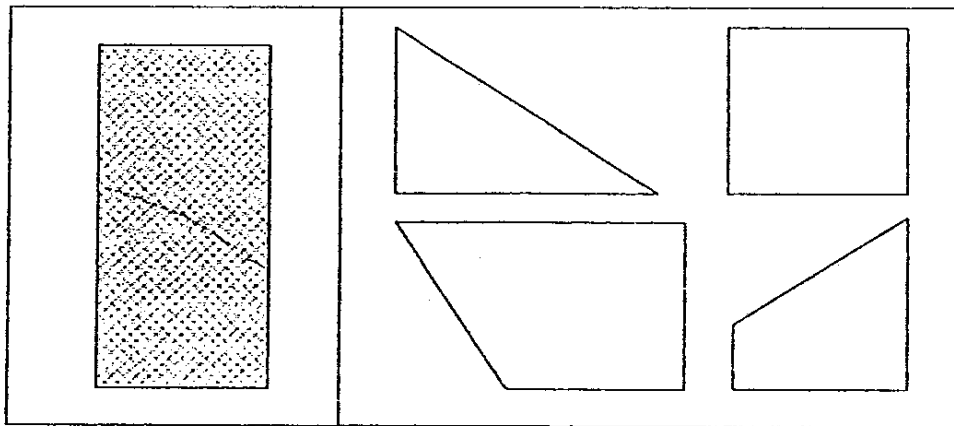

Study the diagram below carefully. Then, answer Questions 28 and 29.

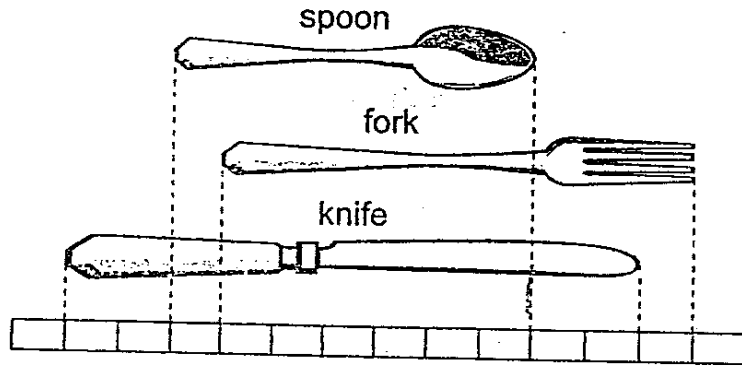

28. The knife is _____ long.

29. The fork is _____ longer than the spoon.

30. Study the diagrams below and answer the following questions.

Use  as 1 unit.

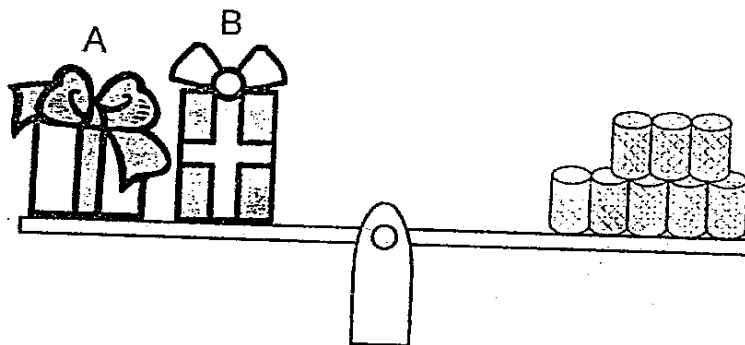
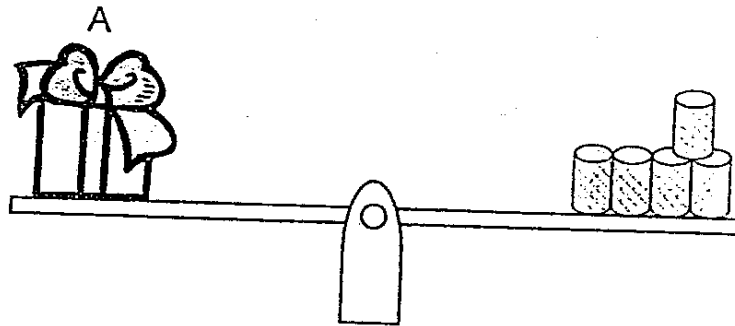

(a) The mass of Present A is _____ units.

(b) The mass of Present B is _____ units.

31. Study the diagrams below.

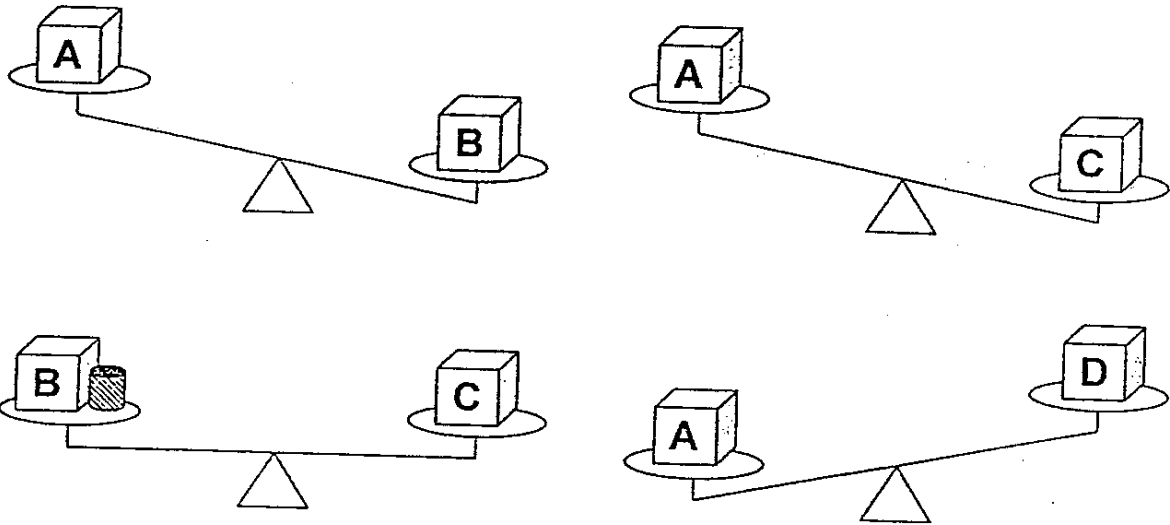

Arrange the boxes in order from the heaviest to the lightest.

, , ,

32. Which number from Set B should be moved to Set A so that the sum of the numbers in Set A and Set B will be the same?

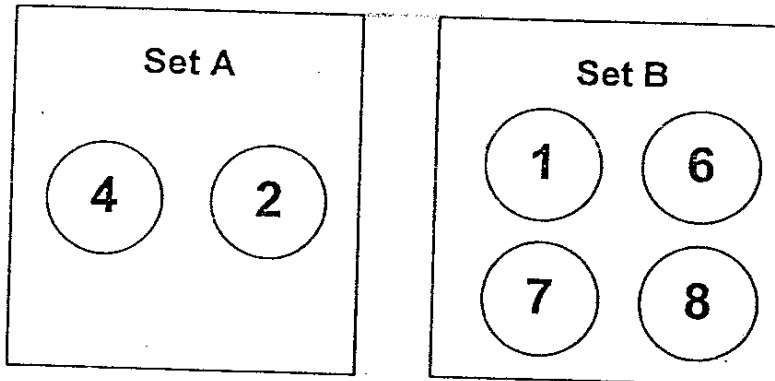

33. Peter has 3 cards as shown below. What is the **greatest** number formed using **any two** of these cards?

9

3

6

34. Arrange these numbers from the smallest to the greatest.

25, 71, 92, 64,

smallest

greatest

35. What is the missing number in the box?

$$\begin{array}{r}
 \boxed{?} 5 \\
 + 36 \\
 \hline
 61 \\
 \hline
 \end{array}$$

36. What are the values of X and Y?

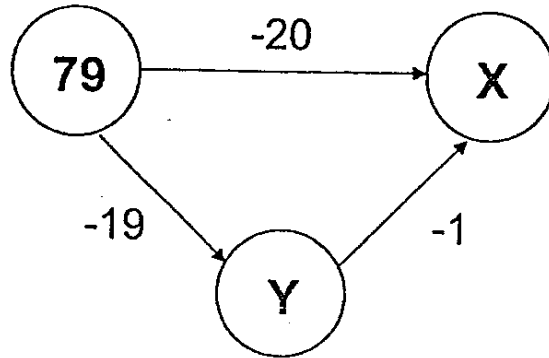

X:

Y:

37. Five numbers are given below. Use 3 of the numbers to complete the addition sentence. Each number can be used only once.

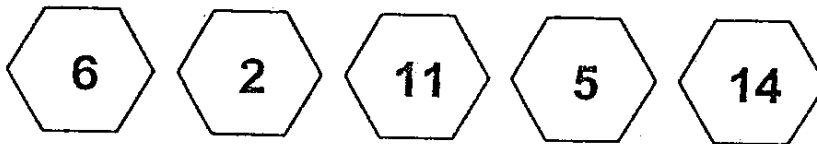

$$4 + \square + \square = \square$$

38. Add 47 to 16.

39. There were 51 passengers in a bus. Some passengers alighted at the first bus stop. How many passengers alighted at the first bus stop if 39 passengers were left in the bus?

40. Four people can sit around a square table as shown below. How many of such tables, arranged to form a long table as shown, are needed for 12 people?

(You may draw a diagram to help you solve the question.)

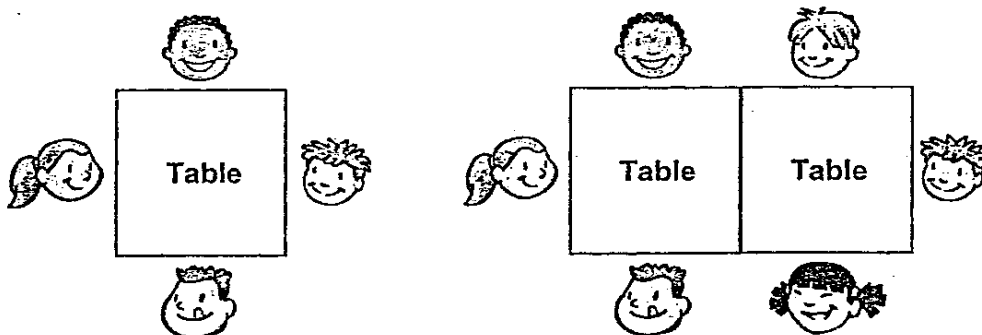

Section C

Questions 41 to 45 carry 4 marks each.
Do these word problems carefully.
Show your working in the space provided.

(Total: 20 marks)

41. Sandy has 19 dolls. Mei Mei has 7 fewer dolls than Sandy.
How many dolls does Mei Mei have?

A visual equation for problem 41: a square, a circle, a square, an equals sign, and a square.

Mei Mei has _____ dolls.





42. Mr Yong sold 42 pineapple tarts on Monday.
He sold 12 more tarts on Tuesday.
How many tarts did he sell on Tuesday?

A visual equation for problem 42: a square, a circle, a square, an equals sign, and a square.

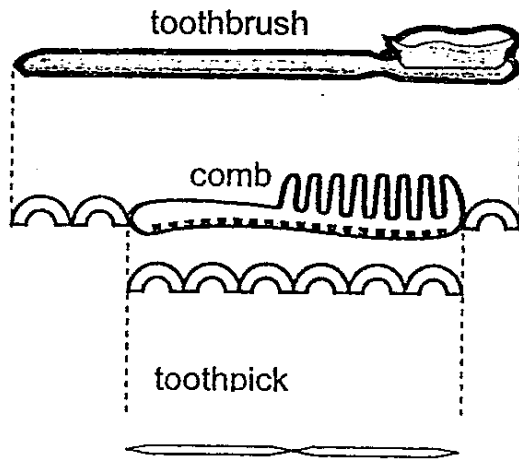
He sold _____ tarts on Tuesday.

43. Use the diagram below to answer the following questions.



- (a) The comb is about _____  long.
- (b) The toothbrush is _____  longer than the comb.
- (c) The length of a toothpick is about _____  long.
- (d) The length of the toothbrush is about _____  long.

44 Study the following diagrams carefully and answer the questions.

Use  as 1 unit.

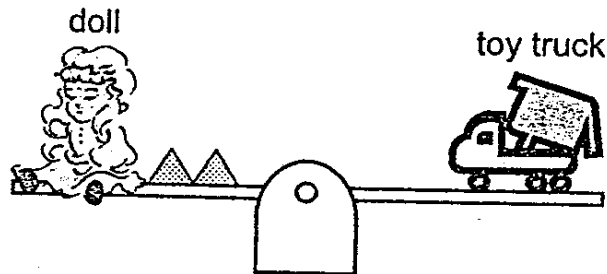
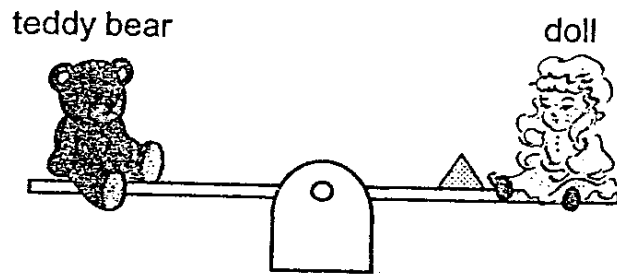
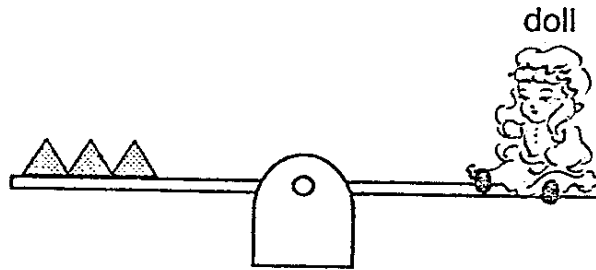

- (a) The mass of the doll is _____ units.
- (b) The mass of the teddy bear is _____ units.
- (c) The mass of 3 toy trucks is _____ units.

45. There are 74 children in the hall. 41 of them are boys.

(a) How many girls are there in the hall?

$$\square \bigcirc \square = \square$$

There are _____ girls in the hall.

(b) How many more boys than girls are there in the hall?

$$\square \bigcirc \square = \square$$

There are _____ more boys than girls in the hall.

☺ *End of Paper* ☺
Please Check Carefully

Setters: Ms Asfalinda
Ms Michelle Kee

Answer Sheets

Nanyang Pri 1 CA2 / 2006 Mathematics

- 1) 4 2) 3 3) 4 4) 2 5) 2
6) 1 7) 1 8) 2 9) 2 10) 4
11) 4 12) 3 13) 3 14) 4 15) 2

16. $12 \begin{array}{l} \diagup 8 \\ \diagdown 4 \end{array}$

17. $8 - 2 = 6$

18. A : square
B : circle

19. Twenty-eight
One hundred

20. $32 + 7 = \underline{39}$

21. $9 - 6 = 3$

22. $6 - 1 = \underline{5}$ circles were hidden

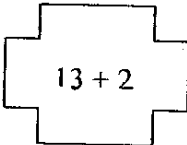
23. 
 $13 + 2$

24. $29 - 22 = 7$

25. $27 - \underline{19} = 7 + 1$
 $8 = 8$



28. 11 long

29. 2 longer than the spoon.

30 A = 5 units

31 C, B, A, D

a.

30 Present B = $8 - 5 = \underline{3}$ units



b.

32. Set B = 8

33. 96

34. 25, 64, 71, 92

35. $61 - 36 = \underline{25}$

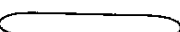
36. $X : 79 - 20 = 59$
 $Y : 79 - 19 = 60$
 $Y - 1 = 60 - 1 = 59$
37. $4 + \underline{5} + \underline{6} = \underline{14}$
38. $47 + 16 = 63$
39. $51 - 39 = \underline{12 \text{ passengers}}$
40. 4 peoples = 1 table
6 peoples = 2 tables
12 peoples = 5 tables
41. $19 - 7 = 12 \text{ dolls}$
Mei Mei has 12 dolls.
42. $42 + 12 = 54 \text{ pineapples}$
He sold 54 pineapples on Tuesday.
- 43a. Comb = 6  long.
- 43b. Toothbrush = 3  long
 $9 - 6 = 3$
- 43c. Toothpick = 3  long
 $6 \div 2 = 3$
- 43d. Toothbrush = 9
Toothpick = 6
 $9 - 6 = 3$ 
- 44a. Doll is 3 units
- 44b. Teddy bear is $3 + 1 = 4$ units
- 44c. 1 toy truck = $3 + 2 = 5$ units
3 toy trucks = $5 \times 3 = 15$ units
The mass of 3 toy trucks is 15 units
- 45a. $74 - 41 = 33 \text{ girls}$
There are 33 girls in the hall.
- 45b. $41 - 33 = 8 \text{ more boys.}$
There are 8 more boys than girls in the hall.