

**SINGAPORE CHINESE GIRLS' SCHOOL
SECOND SEMESTRAL ASSESSMENT 2015**

SCIENCE

PRIMARY THREE

NAME: _____ () DATE: _____

CLASS: PRIMARY 3 SY / C / G / SE / P

BOOKLET A

20 questions

40 marks

Total time for Booklets A& B: 1 h 25 min

DO NOT OPEN THIS BOOKLET UNTIL YOU ARE TOLD TO DO SO.

FOLLOW ALL INSTRUCTIONS CAREFULLY.

Part I (20x 2 marks)

For each question from 1 to 20, four options are given. One of them is the correct answer. Make your choice (1, 2, 3 or 4). **Shade the correct oval (1, 2, 3 or 4) on the Optical Answer Sheet.**

1. When the tortoise is touched, it hides itself in the shell.
When food is placed near it, it sticks its head out of the shell.

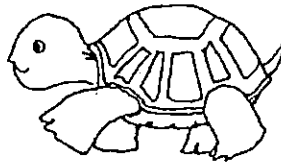

Tortoise

What characteristic of living things does the tortoise show?

- 1) Living things can grow.
- 2) Living things can reproduce.
- 3) Living things need air, food and water.
- 4) Living things respond to changes around them.

2. Jane observed the different leaves as shown below. All the leaves were green.



Leaf A



Leaf B



Leaf C

Which one of the following is the function of the leaves?

- 1) They trap water for the plant.
- 2) They transport water for the plant.
- 3) They allow exchange of gases to take place.
- 4) They transport food to other parts of the plant.

3. Which one of the following statements below about the human body system is true? .

- 1) The digestive system transports air to other parts of the body.
- 2) The respiratory system helps to transport food to all parts of the body.
- 3) The circulatory system consists of the heart, blood and blood vessels.
- 4) The skeleton system does not need the muscular system to move the human body.

4. The flowchart below shows the properties of Materials A, B, C and D.

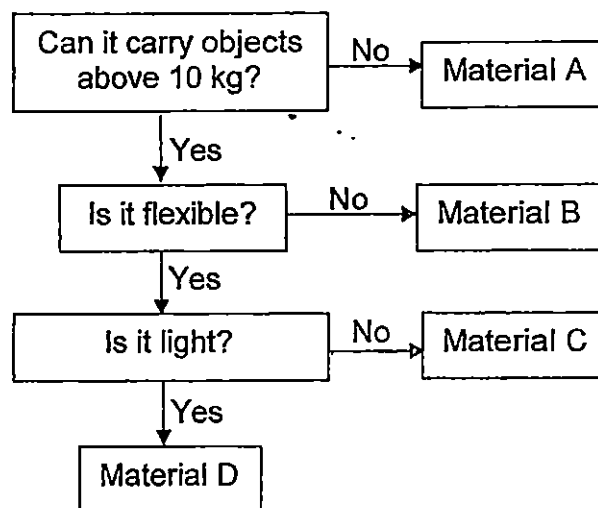

Which Material, A, B, C or D, is most suitable for making a grocery bag that is flexible, light and can carry objects above 10kg?

- 1) A
- 2) B
- 3) C
- 4) D

5. Jack classified the things he had into 2 groups as shown below.

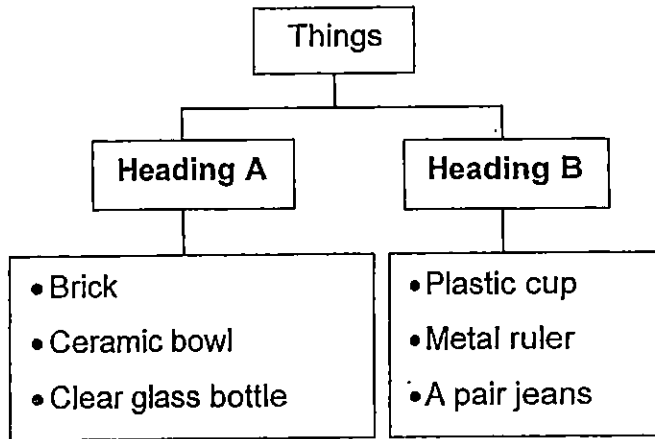

How did Jack classify his items?

	Heading A	Heading B
1)	Easily breakable	Not easily breakable
2)	Allow light to pass through	Does not allow light to pass through
3)	Made from things never alive	Made from things once alive
4)	Can float on water	Cannot float on water

6. Which of the following statement(s) about Part S of the plant is/are true?

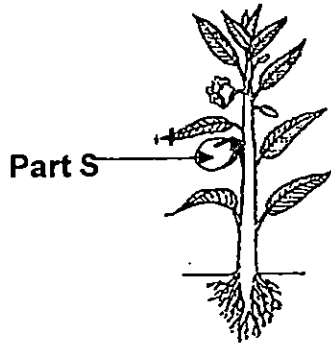

A: It makes food for the plant.

B: It helps the plant to stay upright.

C: It contains seeds for the plant to reproduce.

1) C only

3) A and B only

2) A and C only

4) A, B and C

7. Which of the following organs are part of the human respiratory system?

- 1) Nose, windpipe, lungs
- 2) Lungs, gullet, windpipe
- 3) Mouth, windpipe, stomach
- 4) Mouth, gullet, stomach

8. The diagram below shows the human digestive system.

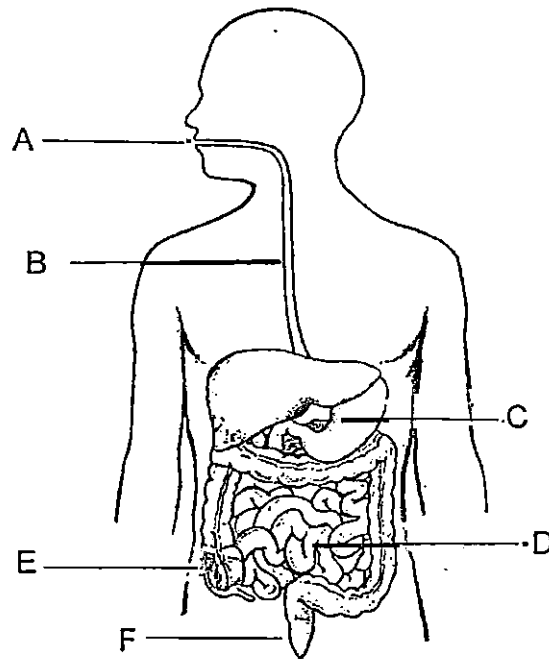

Which parts of the digestive system produce digestive juices?

- 1) B, E and F only
- 2) A, B, D and E only
- 3) A, C and D only
- 4) C,D, E and F only

9. Study the flowchart below carefully.

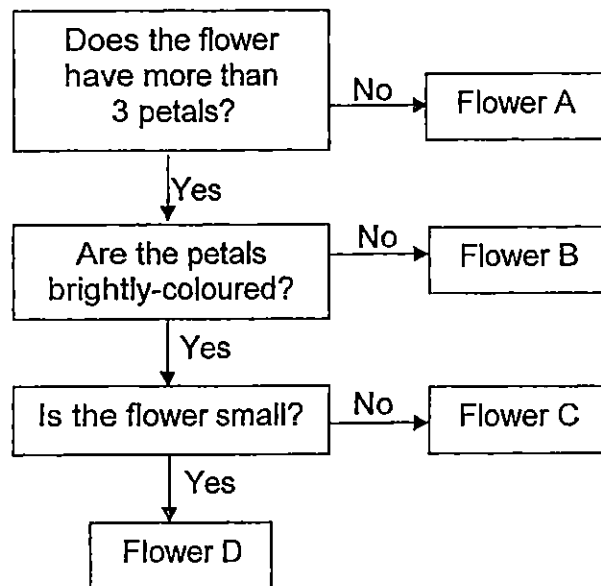

Based on the above flowchart below, which Flower A, B, C or D best describes the flower below?



Characteristics:

- Has 5 petals
- Brightly-coloured petals
- Flower is large

1) A

2) B

3) C

4) D

10. Queenie recorded the number of paper clips that Parts A, B, C, D and E of Magnet X attracted in the bar graph below.

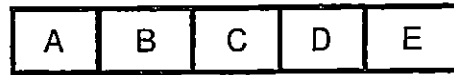

Magnet X

Which one of the following graphs below correctly represents part, A, B, C, D and E of Magnet X?

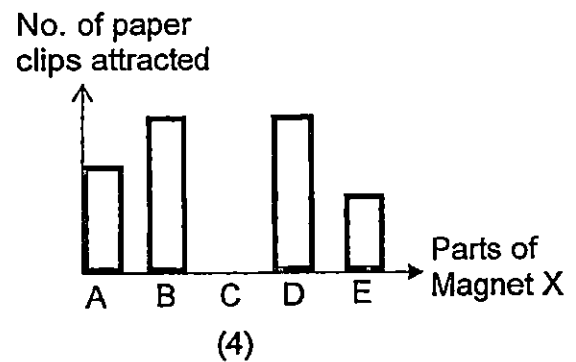
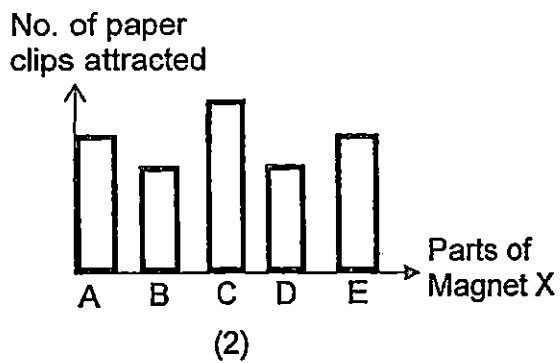
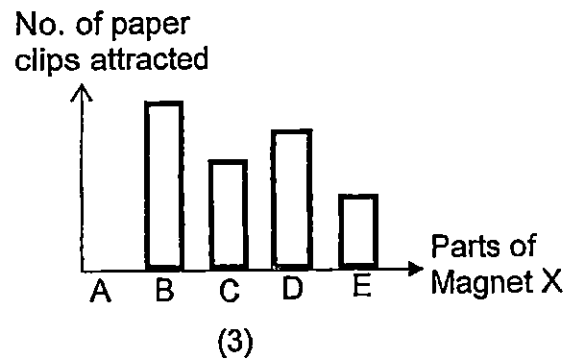
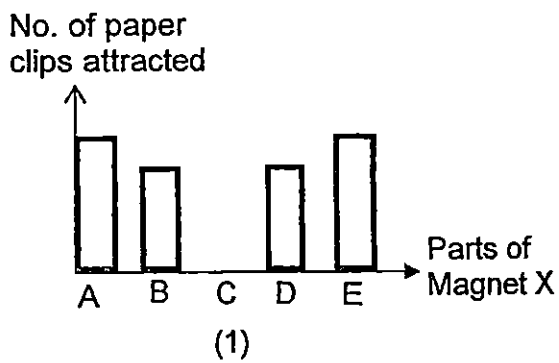

11. The diagram below shows 3 objects, X, Y and Z.

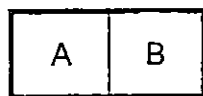

Object X



Object Y



Object Z

Eva placed the objects as shown above next to each other and observed that Object X repelled Object Y but Object Y attracted Object Z as shown below.

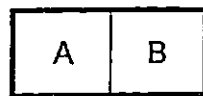

Object X

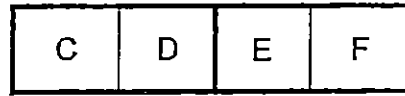

Object Y

Object Z

Which of the following conclusion(s) is/are correct?

- 1) Only Object Z is a magnet.
- 2) Object Z is made of plastic.
- 3) Object X is definitely a magnet.
- 4) End B of Object X will repel End D of Object Y.

12. Stacy hanged Magnets E, F, G and H from a pole. She then placed them above a tray of iron thumbtacks and recorded her observation as shown below.

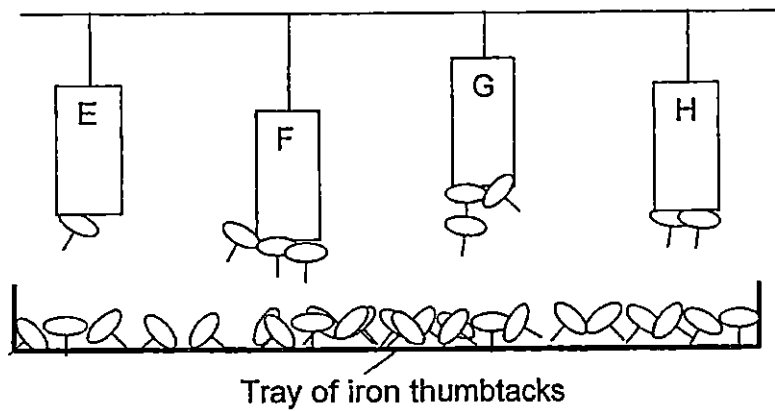

Which magnet, E, F, G or H is the strongest magnet?

- 1) E
 - 2) F
 - 3) G
 - 4) H
13. Study the classification chart below.

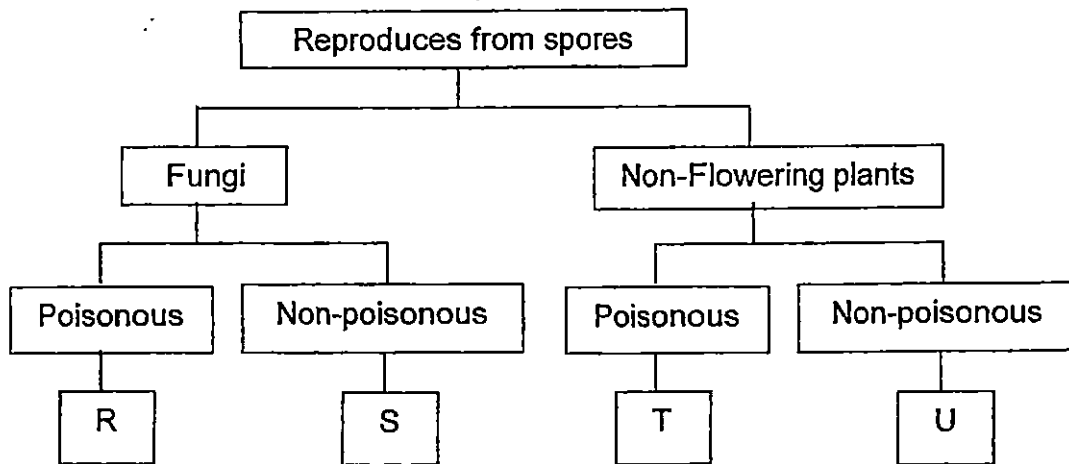

Tom found an edible mushroom. In which group, R, S, T or U does it belong to?

- 1) R
- 2) S
- 3) T
- 4) U

14. Lily filled 2 identical containers, X and Y, with equal amounts of water. She placed a plant in Container Y only. Next, she placed the 2 set-ups in a bright place for 1 week.

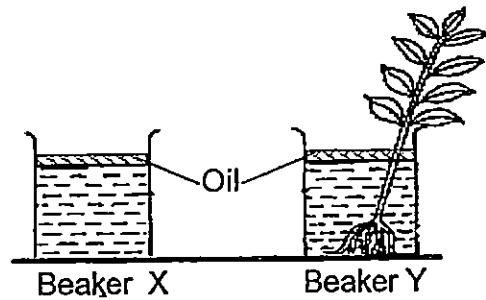

	Beaker X	Beaker Y
Volume of water at the start of experiment	200ml	200ml
Volume of water after 1 week	200ml	187ml

Based on the results, which one of the following is correct?

- 1) The roots of the plant absorbed water.
- 2) Beaker Y has more water left than beaker X.
- 3) The oil caused the water in Beaker Y to decrease.
- 4) The amount of water in both beakers decreased after 1 week.

15. Eunice used a bar magnet to stroke 4 identical iron nails, A, B, C and D. Which iron nail would be able to attract the most number of paper clips?

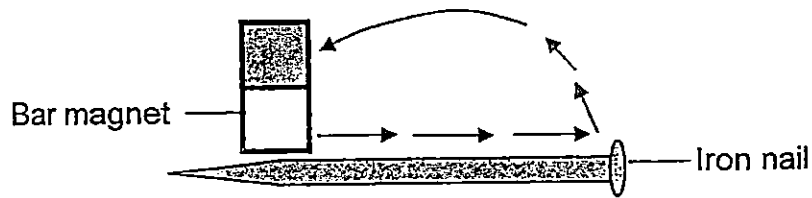

	Iron nail	Number of strokes
1)	A	15
2)	B	30
3)	C	45
4)	D	60

16. Allan classified the following plants into 2 groups as shown below.

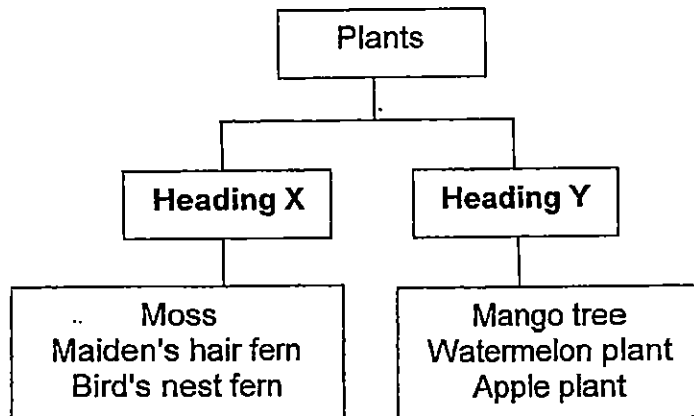

Which of the following correctly represents headings X and Y?

	Heading X	Heading Y
1)	Reproduce by spores	Reproduce by seeds
2)	Cannot make food	Can make food
3)	Land plant	Water plant
4)	Contains many seeds	Contains one seed

17. Which one of the following diagrams shows the correct order of a human digestive system?

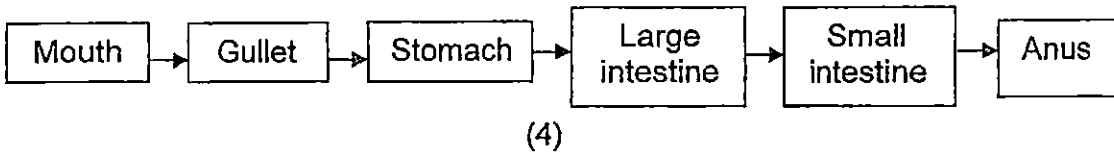
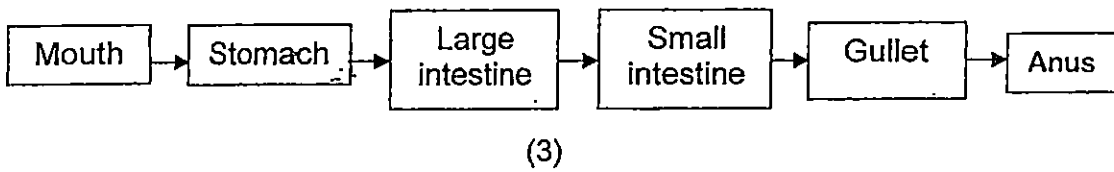
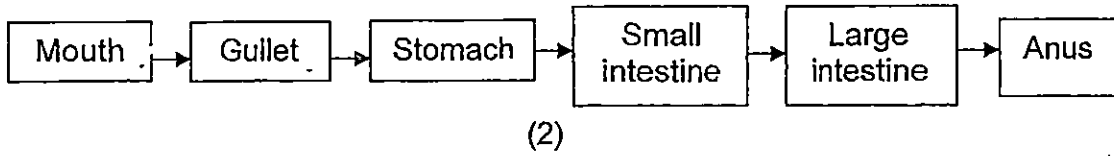
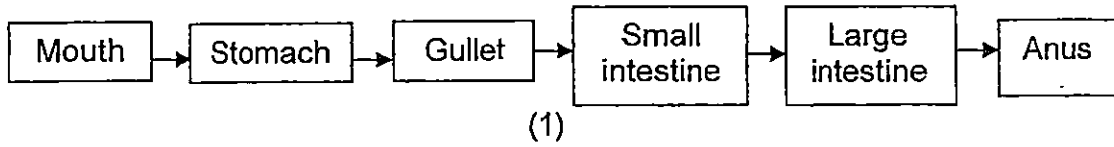

18. Mrs Lee conducted an experiment to find out which diaper brands, W, X, Y and Z, can absorb the most water. She poured equal amount of water onto each diaper and measured the amount of water not absorbed by the diaper. The result of the experiment is shown below.

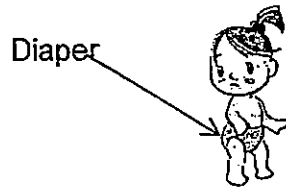

	Brand W	Brand X	Brand Y	Brand Z
Amount of water poured onto the diaper (ml)	100	100	100	100
Amount of water not absorbed by the diaper (ml)	10	45	0	15

Which brand of diaper can absorb the most water?

- 1) Brand W
 - 2) Brand Y
 - 3) Brand X
 - 4) Brand Z
19. Jill cut the stem of a white flower into 2 equal parts and placed it in blue-coloured and red-coloured water as shown below. She placed the set-up near a window for 2 days.

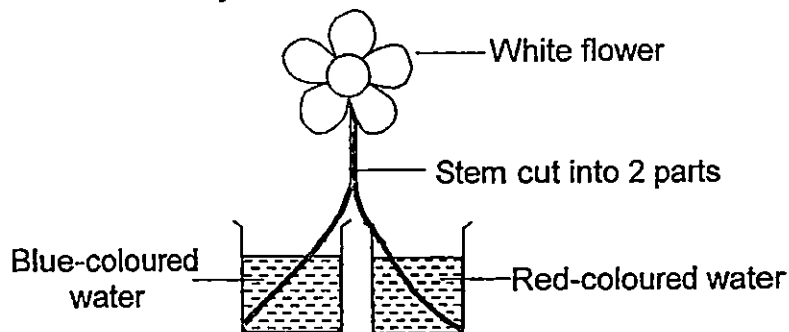

Which one of the following is most likely to happen after 2 days?

- 1) The flower will turn purple after 2 days.
- 2) The flower will remain white after 2 days.
- 3) Half of the flower will turn red, while the other half of the flower will turn purple after 2 days.
- 4) Half of the flower will turn red, while the other half of the flower will turn blue after 2 days.

20. Study the flow chart below.

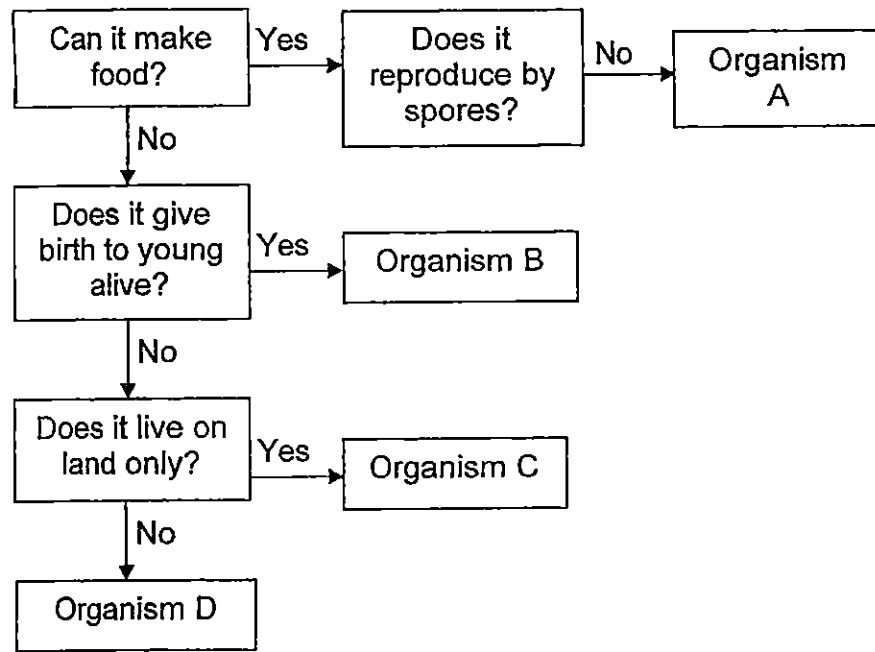

Which organism, A, B, C or D, fits the characteristics of a butterfly?

- 1) A
- 2) B

- 3) C
- 4) D

SINGAPORE CHINESE GIRLS' SCHOOL
SECOND SEMESTRAL ASSESSMENT 2015

SCIENCE

PRIMARY THREE

NAME: _____ ()

DATE: _____

CLASS: PRIMARY 3SY / C / G / SE / P

Booklet A		40
Booklet B		30
Total		70

Parent's Signature _____

BOOKLET B

9 questions

30 marks

Total time for Booklets A& B: 1 h 25 min

DO NOT OPEN THIS BOOKLET UNTIL YOU ARE TOLD TO DO SO.

FOLLOW ALL INSTRUCTIONS CAREFULLY.



Part II(30 marks)

Answer all the following questions:

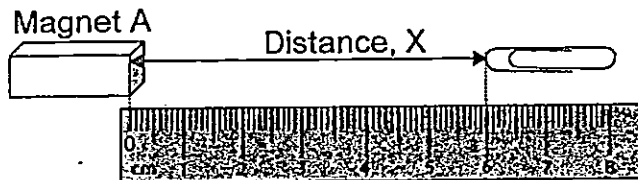
21. Harry placed Magnet A next to the ruler as shown below. He then moved a paper clip slowly towards Magnet A and recorded Distance X, just before the paper clip was attracted to Magnet A.

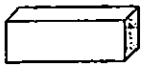

Harry then repeated the experiment with Magnets B and C.

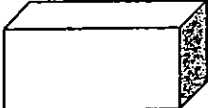
	Magnet	Distance X (cm)
A		1
B		4
C		2

- a) Which magnet is the strongest? (1m)

- b) Based on the experiment above, what can Harry conclude about the size of the magnet and its magnetic strength? (1m)

22. Irene needed to remove the underground parts of plants X and Y as shown below.
(Parts above ground are not shown.)

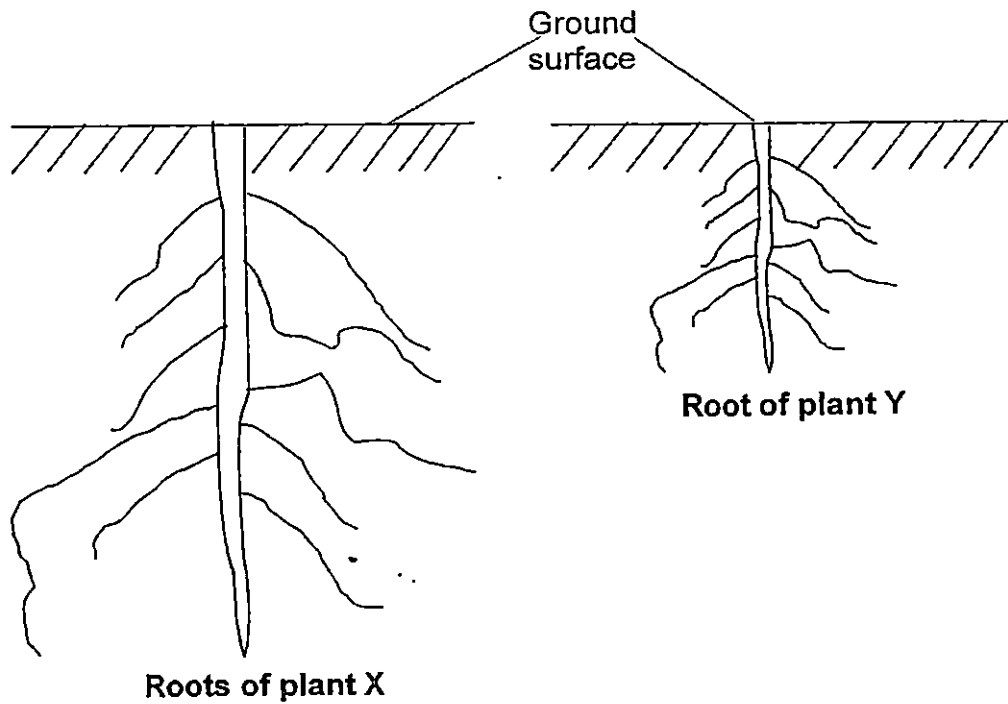

- a) Roots take in _____ and _____ for the plant. (1m)
- b) Which plant, X or Y, is harder to remove from the soil?(1m)
- c) Give a reason why the plant you have chosen in (a) is harder to remove from the soil. (1m)

23. Jane ate a biscuit during recess. The amount of digested biscuit that left the different parts of her digestive system is shown in the graph below.

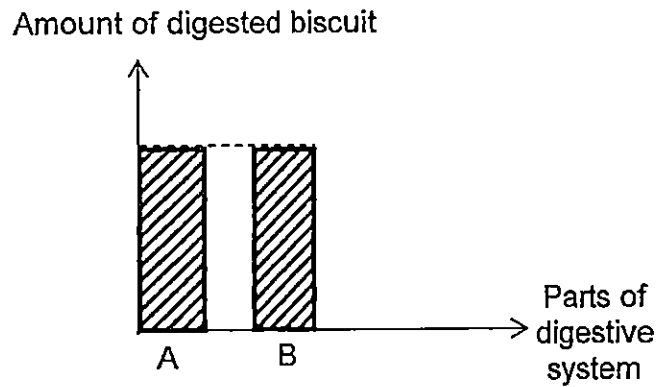

- a) Which 2 parts of the digestive system can most likely represent A and B in the above graph? Put a tick (✓) to the correct pair in the boxes below. (1m)

	A	B	Put a tick (✓) to the correct pair
i)	Mouth	Stomach	
ii)	Gullet	Small intestine	
iii)	Mouth	Gullet	
iv)	Stomach	Large intestine	

- b) Jane told her classmate that teeth are able to digest food. Why is her statement wrong? (1m)

c) Study the graph below carefully.

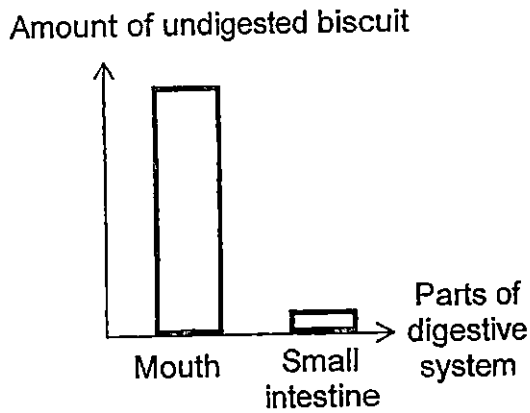

Graph X

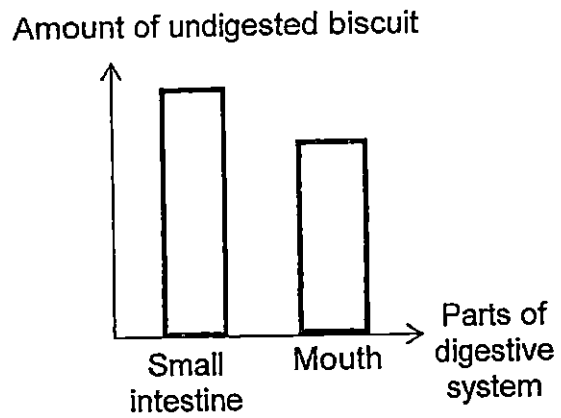

Graph Y

Which graph, X or Y, correctly shows the amount of undigested biscuit that left the mouth and small intestine as it went through the digestive system? (1m)

24. Jane took 2 of her stool samples for test and recorded the amount of water in the stool in the table below.

*Stool sample is waste which comes out through the anus.

Stool sample	Amount of water in the stool (cm ³)
A	80
B	12

a) Which part of her digestive system is mainly responsible for controlling the amount of water present in the stool? (1m)

b) Which stool sample, A or B, most likely shows that Jane might be having diarrhoea. Explain your choice. (2m)

25. Mrs Tan recorded the mass of X and Y over 8 months in the table below.

Month	Mass (g)	
	X	Y
1	300	300
2	400	300
3	500	300
4	600	300
5	700	300
6	800	300
7	900	300
8	1000	300

(a) Tick(✓) in the correct column below to indicate if the mass of X or Y increased, decreased or remained the same over 8 months. (1m)

	Mass (g)		
	Increased	Decreased	Remained the same
X			
Y			

(b) Label in the boxes below which is X and Y? (1m)



A plant



A rock

(c) State 2 differences between living things and non-living things. (2m)

(1): _____

(2): _____

26. Table A below shows some properties of 3 types of materials.

Property	Material X	Material Y	Material Z
Waterproof	Yes	No	Yes
Allow light to pass through	No	Yes	Yes
Lightweight	Yes	No	Yes

(a) Based on Table A above, state 2 differences between Materials Y and Z. (2m)

Difference (1):	
Difference (2):	

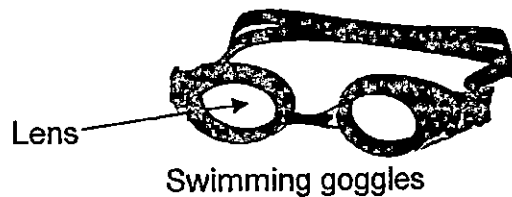

(b) Which Material, X, Y or Z is the best for making the lens of a pair of swimming goggles? Give a reason for your answer based on the information in Table A (2m)

27. Study the flowchart below carefully.

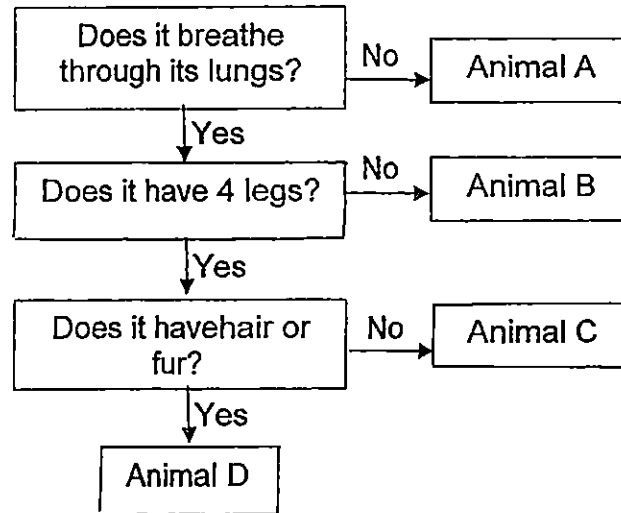

(a) In what way(s) are Animals C and D similar? (2m)

(b) Which animal is most likely to be a crocodile? (1m)

(c) Which animal(s) breathe(s) through lungs? (1m)

28. Paul had 4 slices of identical bread A, B, C and D of equal size and thickness.



A slice of bread

He added different amounts of water to Bread A, B, C and D as shown in the graph below and placed them in his kitchen for 3 days.

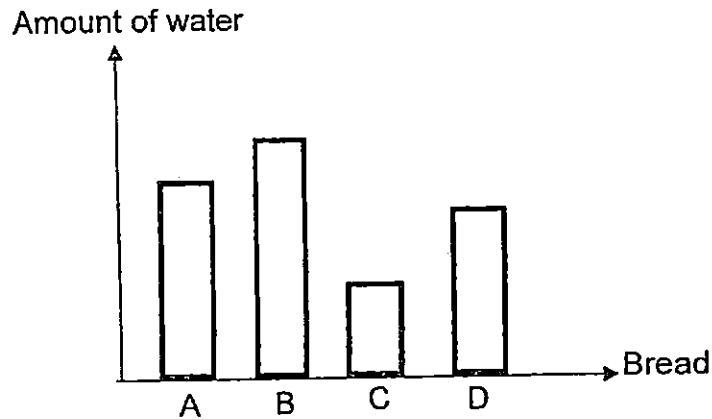

a) Based on the above information, match the amount of mould that will grow on Bread A, B, C or D in the graph below. (2m)

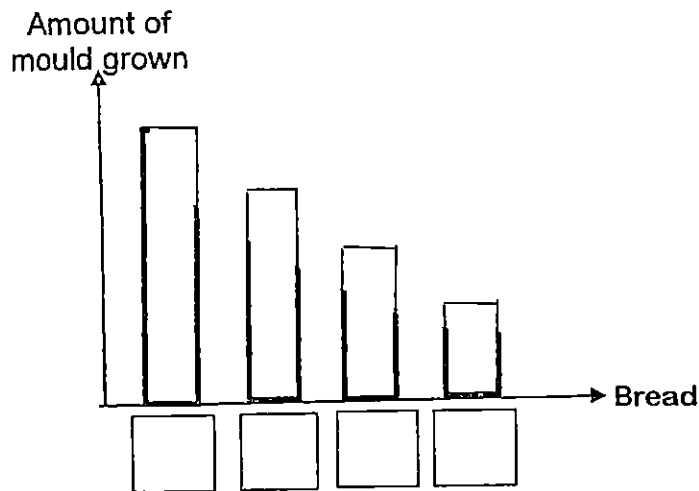

b) To make sure that mould will grow on all the slices of bread after 3 days, tick (✓) where the bread should be placed.

You may tick more than one. (1m)

Freezer	Science room cupboard	Refrigerator	Classroom bookshelf

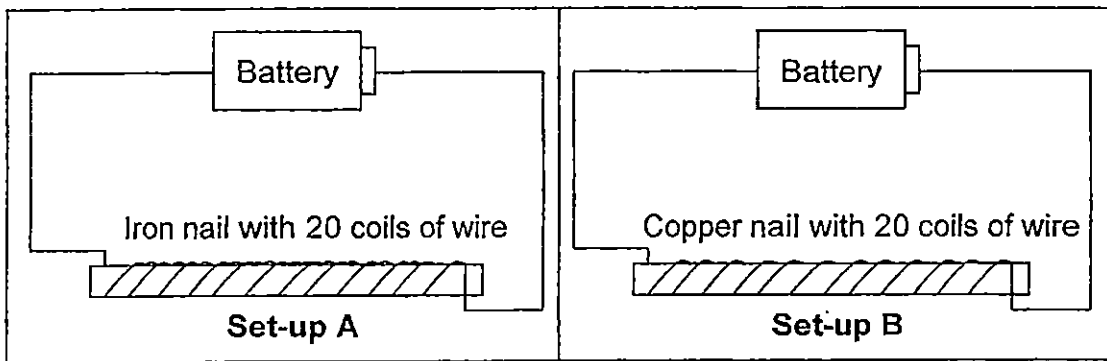

29. Sherman conducted 2 experiments as shown below.



a) In which setup, A or B, will the nail become an electromagnet? (1m)

b) Explain your answer in (a). (1m)

c) Tick (✓) in the appropriate boxes to show what you think will happen to the silver coin and the steel paper clip if Sherman placed them one at a time next to an electromagnet? (2m)

Objects	Attracted to the electromagnet	Repel the electromagnet	No change
i) Silver coin 			
ii) Steel paper clip 			

END.





SINGAPORE CHINESE GIRLS' SCHOOL PRIMARY 3 SCIENCE SA2 2015 Answers

Part I			
1) 4	6) 1	11) 3	16) 1
2) 3	7) 1	12) 3	17) 2
3) 3	8) 3	13) 2	18) 2
4) 4	9) 3	14) 1	19) 4
5) 1	10) 1	15) 4	20) 3

Part II

Qn	Suggested Answers			
21a	Magnet B			
21b	The magnetic strength of a magnet does not depend on its size.			
22a	Water, mineral salts			
22b	X			
22c	The roots are longer.			
23a		A	B	Put a tick (✓) to the correct pair
	i)	Mouth	Stomach	
	ii)	Gullet	Small intestine	
	iii)	Mouth	Gullet	✓
iv)	Stomach	Large intestine		
23b	The teeth do not have/produce digestive juices to digest food.			
23c	X			
24a	Large intestine			
24b	Stool A. It has <u>more</u> water than Stool B.			
25a	Mass (kg)			
		Increased	Decreased	Remained the same
	X	✓		
Y			✓	

25b	Plant - X Rock - Y			
25c	Living things need air, food and water/ can respond to changes around them/ die/ reproduce/ move on their own, but non-living things don't/ cannot.			
26a	Material Z is waterproof but Material Y is not. Material Z is lightweight but Material Y is not.			
26b	Material Z. It is lightweight, allows light to pass through and is waterproof.			
27a	Both have 4 legs and breathe through lungs.			
27b	Animal C			
27c	Animals B, C and D			
28a	B, A, D, C			
28b	Freezer	Science room cupboard	Refrigerator	Classroom bookshelf
		✓		✓
29a	A			
29b	iron is a magnetic material but copper is not a magnetic			
29c	Objects	Attracted to the electromagnet	Repel the electromagnet	No change
	i) Silver coin 			✓
	ii) Steel paper clip 	✓		