

NANYANG PRIMARY SCHOOL

PRIMARY THREE SCIENCE

2022

PRACTICE PAPER

BOOKLET A

Name: _____ ()

Class: 3 ()

Date: _____

Section A: Multiple Choice Questions [44 marks]

For each question from 1 to 22, four options are given. One of them is the correct answer. Indicate your choice in this booklet and shade the correct oval (1, 2, 3 or 4) on the Optical Answer Sheet provided.

1. The table below shows some characteristics of living things.
A tick (✓) in the box shows that the characteristic is present for A, B and C.

| Characteristic | A | B | C |
|-------------------------------------|---|---|---|
| It needs water to survive. | ✓ | | ✓ |
| It can make its own food. | | | ✓ |
| It responds to surrounding changes. | ✓ | | ✓ |

Which of the following correctly represents A, B and C?

| | A | B | C |
|-----|--------------|--------------|--------------|
| (1) | tomato plant | toy dog | cat |
| (2) | toy dog | cat | tomato plant |
| (3) | cat | tomato plant | toy dog |
| (4) | cat | toy dog | tomato plant |

2. Study the two plants shown below.

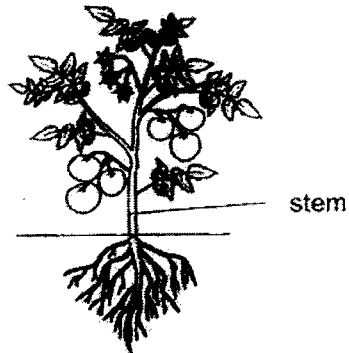

Plant G

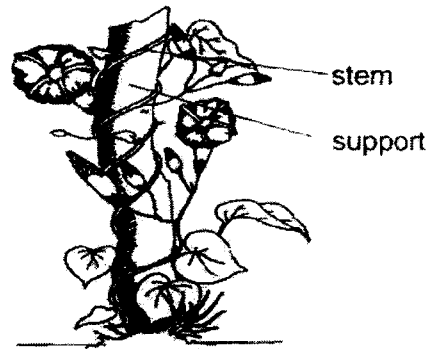

Plant H

John made the following statements about plant G and H.

- A Both have strong stems.
- B Both plants grow on land.
- C Plant G reproduces by seeds
- D Plant H reproduces by spores.

Which of the statement(s) above is/are true about plant G and H?

- (1) A only
- (2) A and D only
- (3) B and C only
- (4) B, C and D only

5. Study the flowchart below.

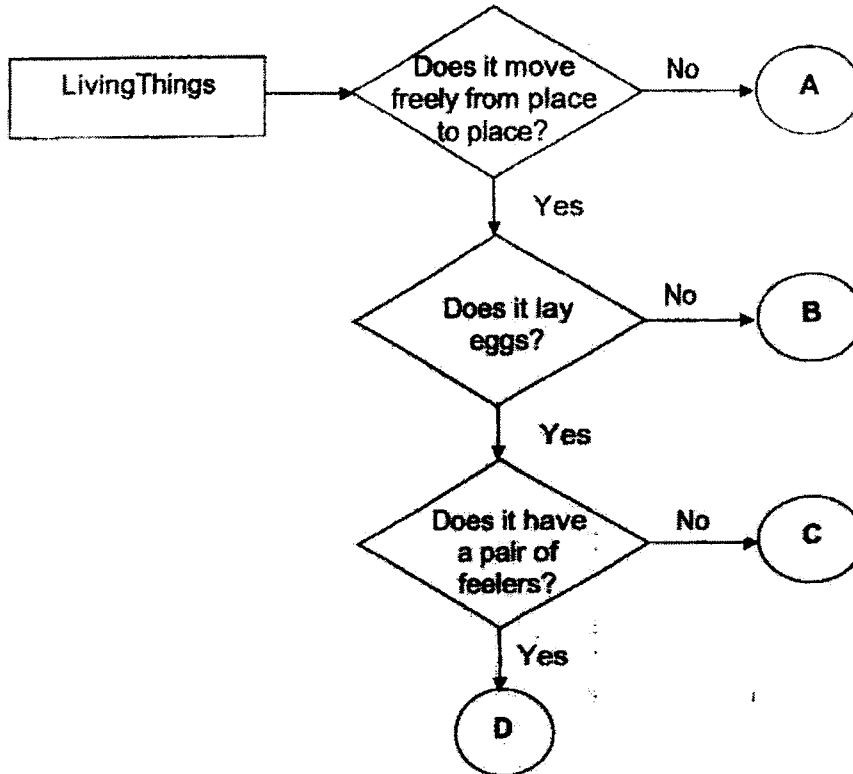

Based on the information above, which of the following best represents A, B, C and D?

| | A | B | C | D |
|-----|-------|------------|----------|---------|
| (1) | plant | amphibians | reptiles | insects |
| (2) | plant | mammals | reptiles | birds |
| (3) | fungi | mammals | fish | insects |
| (4) | fungi | amphibians | fish | birds |

6. Which of the following statements about bacteria is false?

- (1) All bacteria can reproduce.
- (2) All bacteria cause diseases.
- (3) All bacteria need water to survive.
- (4) All bacteria can only be seen clearly using a microscope.

7. Study the diagram below.



fern



mushroom

How are the living things shown above similar?

- (1) They make their own food.
 - (2) They reproduce by spores.
 - (3) They are non-flowering plants.
 - (4) They feed on other living things.
8. Which one of the following statements about the similarities between fungi and bacteria is correct?
- (1) All fungi and bacteria are harmful to us.
 - (2) All fungi and bacteria can be eaten without harming us.
 - (3) All fungi and bacteria feed on living things dead or alive.
 - (4) All fungi and bacteria can only be seen under a microscope.

* The diagram below shows how the organ systems in the human body work together.

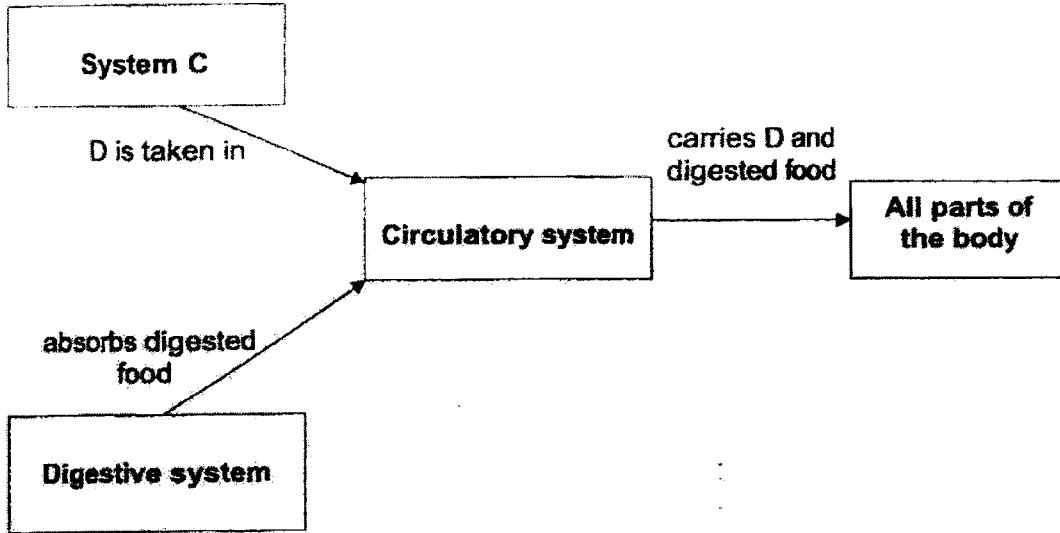

Which of the following best represents system C and D?

| | System C | D |
|-----|--------------------|----------|
| (1) | respiratory system | air |
| (2) | respiratory system | water |
| (3) | muscular system | air |
| (4) | muscular system | water |

10. Study the diagram below.

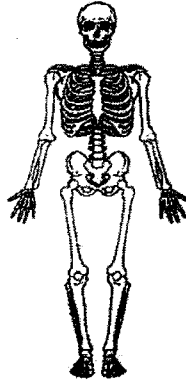

Which of the following statements best describe the functions of the human body system shown above?

- A It protects the organs.
- B It protects the muscles.
- C It gives the body shape.
- D It takes in air from the surroundings.

- | | |
|------------------|------------------|
| (1) A only | (2) B only |
| (3) A and C only | (4) B and D only |

11. The diagram below shows a human digestive system.

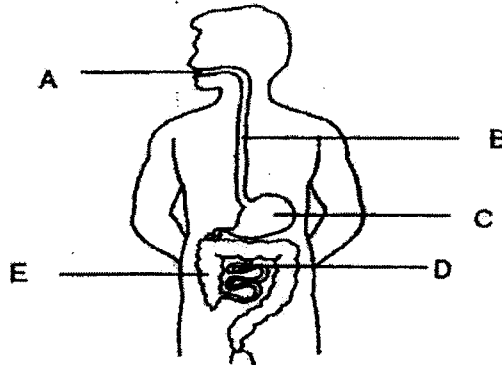

Which of the following parts of the digestive system contain digestive juices?

- | | |
|---------------------|---------------------|
| (1) A, B and C only | (2) A, C and D only |
| (3) B, C and E only | (4) B, D and E only |

12. Mike was given a list of objects. He grouped them into 2 groups, X and Y, as shown below.

| X | Y |
|--|---|
| metal rod glass bottle wooden chair floor tiles | table cloth tissue paper plastic bag aluminum foil |

Which one of the following properties did Mike use to group the objects?

- (1) Flexibility
- (2) Transparency
- (3) Strength
- (4) Waterproof

13. Si Qing listed the properties of 4 materials, J, K, L and M, in the table below.

| Properties | Material J | Material K | Material L | Material M |
|---------------------------------|------------|------------|------------|------------|
| Does it tear easily? | No | No | Yes | No |
| Is it waterproof? | Yes | Yes | Yes | Yes |
| Can most light pass through it? | No | No | Yes | Yes |
| Is it flexible? | No | Yes | Yes | Yes |

Which one of the materials is most suitable for making part F of a face shield?



- (1) Material J
- (2) Material K
- (3) Material L
- (4) Material M

14. Osman carried out an experiment using 4 strips of different materials, P, Q, R and S. The 4 strips have the same length and thickness.

He hung one end of each strip from a hook as shown in the diagram below. At the other end of the strip, he hung 5g-weights, one at a time, until the strip tore.

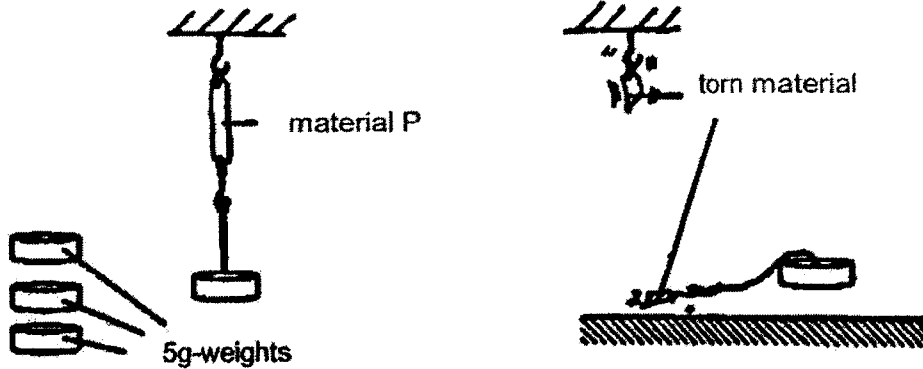

He repeated the experiment with materials, Q, R and S. Osman recorded the number of 5g-weights hung below each strip of material before it tore, in the table below.

| Material | Number of 5-g weights hung to tear material |
|----------|---|
| P | 6 |
| Q | 1 |
| R | 3 |
| S | 9 |

Based on the results of the experiment, which one of the following statements about the materials is true?

- (1) P is lighter than S.
- (2) P is weaker than R.
- (3) Q is the most flexible.
- (4) S is the strongest material.

15. In which one of the following set-ups will the two magnets push each other away?

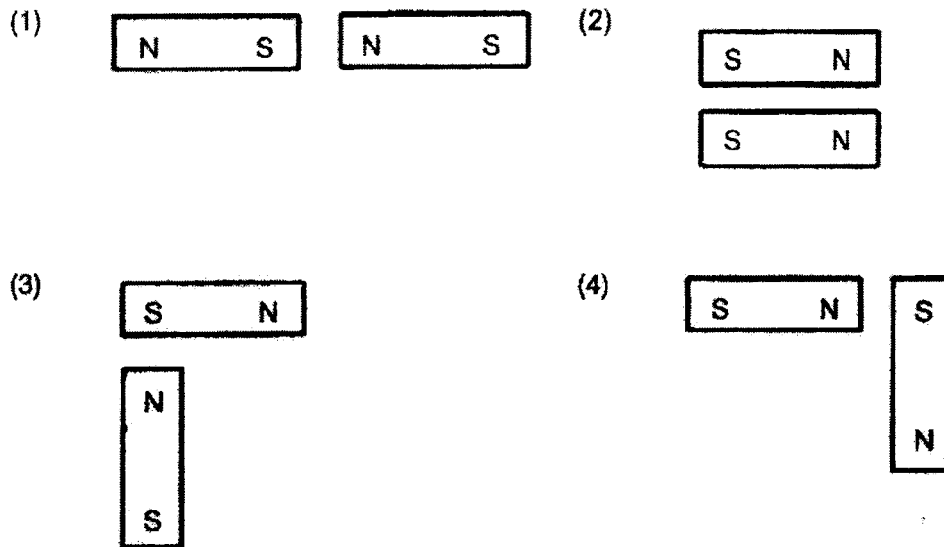

16. The diagram below shows an electromagnet.

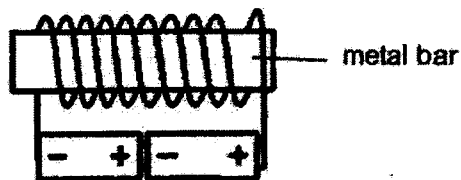

Which one of the following should be done in order for the electromagnet to attract an iron nail from a greater distance?

- (1) Use a thinner wire
- (2) Use only one battery
- (3) Use a bigger metal bar
- (4) Make more coils of wire around the metal bar

17. Diagram 1 below shows a bar magnet lowered onto a pile of steel pins. Diagram 2 shows the bottom view of the magnet.

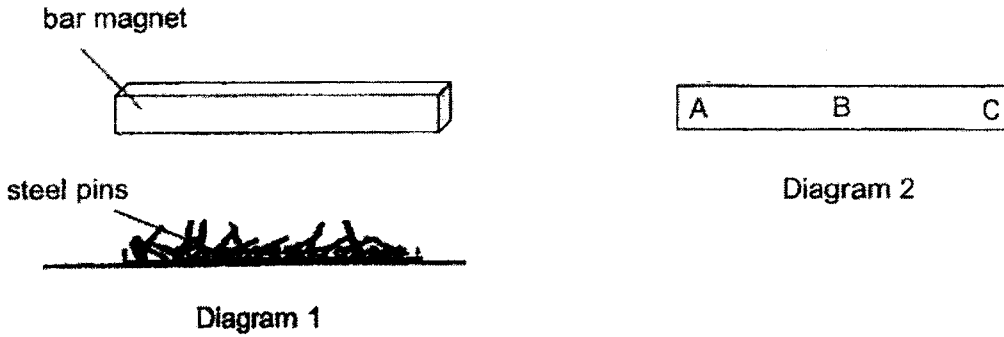

Which one of the following most likely shows the number of pins attracted to the bottom of the magnet at positions A, B and C?

| | A | B | C |
|-----|----|----|----|
| (1) | 6 | 18 | 6 |
| (2) | 12 | 6 | 13 |
| (3) | 15 | 10 | 5 |
| (4) | 10 | 10 | 10 |

18. Three rings, W, X and Y are passed through a wooden rod. Ring X is a magnet.

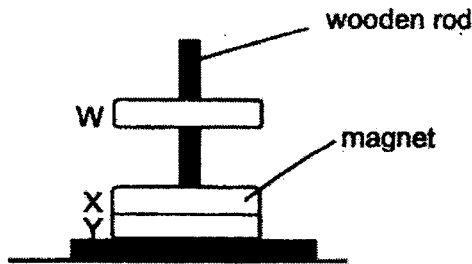

Which one of the following is possible?

| | W | Y |
|-----|--------|--------|
| (1) | rubber | steel |
| (2) | steel | steel |
| (3) | magnet | magnet |
| (4) | steel | magnet |

19. The diagram below shows four magnets, A, B, C and D, of different sizes. Each of the magnets was then placed at an equal distance above a pile of iron nails. The number of iron nails attracted to each magnet was recorded in a table as shown below.

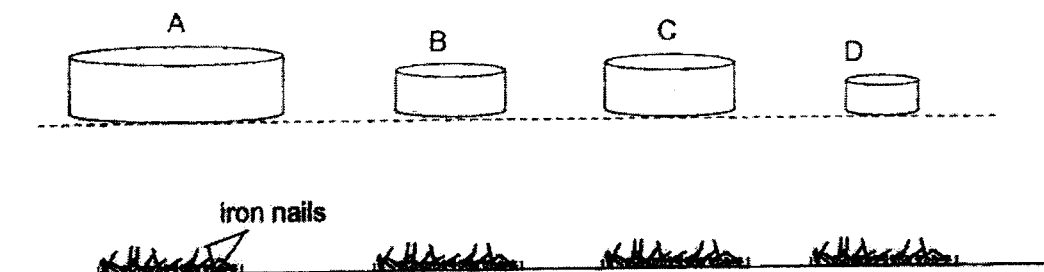

| Magnet | A | B | C | D |
|---------------------------|---|---|----|---|
| Number of nails attracted | 9 | 5 | 12 | 8 |

Based on the experiment above, which one of the following statements is incorrect?

- (1) Magnet A is the strongest magnet.
- (2) Magnet C is stronger than magnet D.
- (3) Magnet B is the weakest among the magnets.
- (4) The strength of the magnet is not affected by its size.

20. Reena arranged four magnets with poles labelled A to H as shown below. The magnets do not repel one another.

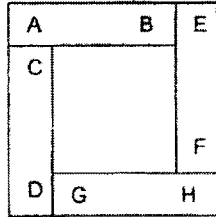

Which one of the following is another possible arrangement of the magnets?

(1)

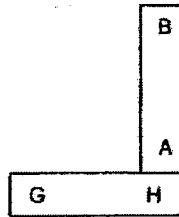

(2)

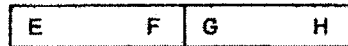

(3)

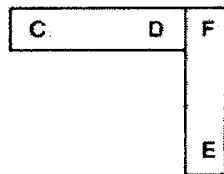

(4)



21. Which one of the following diagrams shows how to make an iron nail into a magnet using the stroking method?

(1)

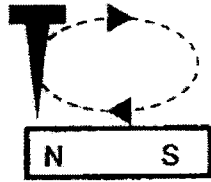

(2)

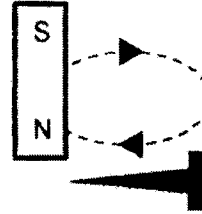

(3)

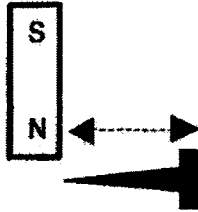

(4)

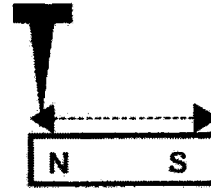

22. Derrick magnetised 2 iron nails and carried out an experiment as shown below.

He suspended one of the magnetised iron nails as shown in Diagram 1.
He placed the other magnetised iron nail on a plastic that was floating in a basin of water as shown in Diagram 2.

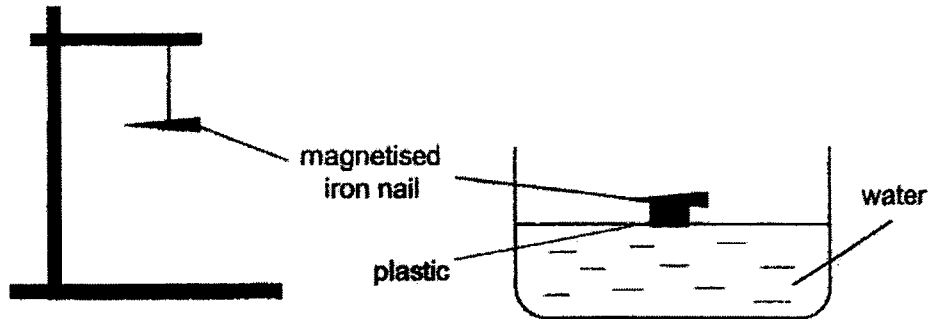

Diagram 1

Diagram 2

Which one of the following shows the direction that each iron nail come to a rest?

| | Suspended iron nail in Diagram 1 | Floating iron nail in Diagram 2 |
|-----|-------------------------------------|------------------------------------|
| (1) | North-South | East-West |
| (2) | East- West | North-South |
| (3) | North-South | North-South |
| (4) | East-West | East-West |

~ END OF BOOKLET A ~

NANYANG PRIMARY SCHOOL

PRIMARY THREE SCIENCE

2022

PRACTICE PAPER

BOOKLET B

Name: _____ ()

Class: 3 ()

Date: _____

Section B: Open-Ended Questions [26 marks]

Write your answers to Questions 23 to 31 in the spaces provided.

23. Min kept her pet in a glass tank as shown below.

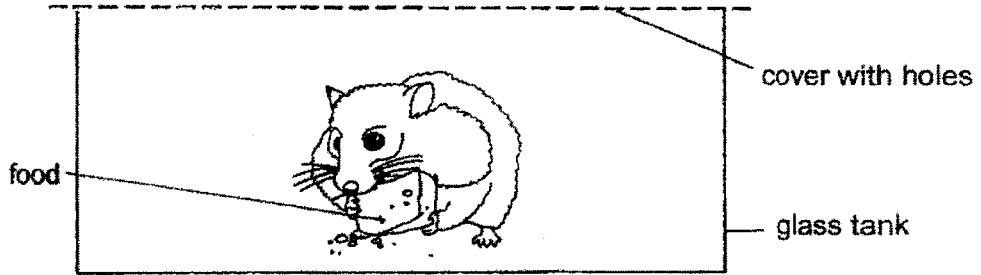

(a) What else should Min provide to ensure that her pet could stay alive? [1]

Min placed a cover over the tank so that her pet will not escape.

(b) Why must the cover have holes? [1]

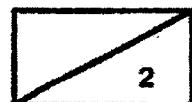

24. The table below shows the characteristics of four plants, A, B, C and D. A tick (✓) shows that the plant has that characteristic.

| Characteristic | Plant A | Plant B | Plant C | Plant D |
|-----------------|---------|---------|---------|---------|
| Produces spores | ✓ | | ✓ | |
| Grows in water | | ✓ | ✓ | |

- (a) Based on the information given in the table above, classify plants A, B, C and D, by writing the letters in the chart below. [1]

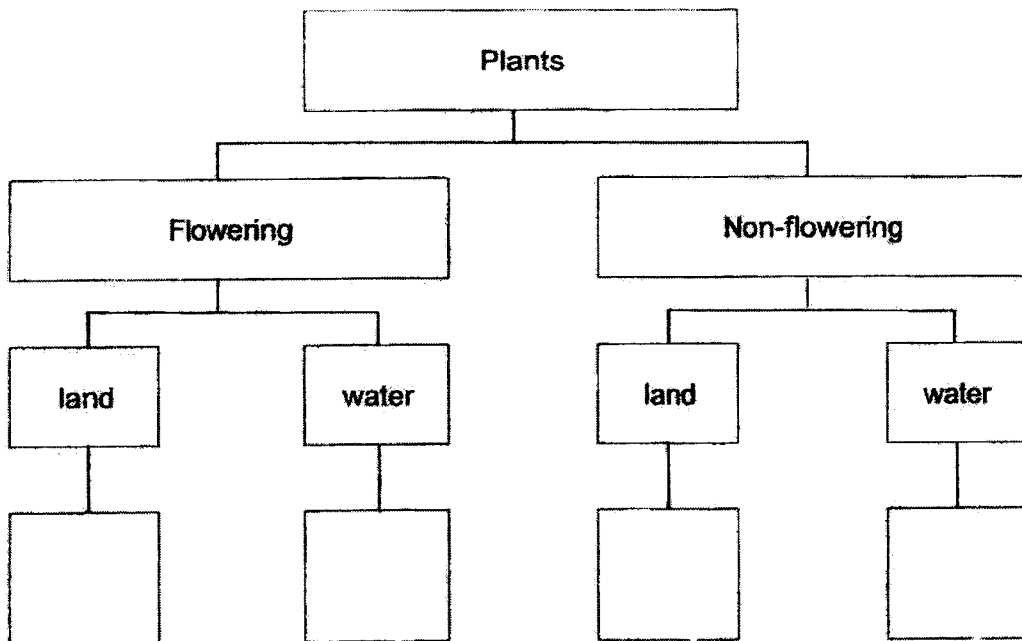

Zac labelled the plant shown below as a non-flowering plant but his teacher told him that it might not be true.

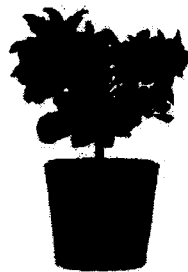

- (b) Give a reason Zac may not be right. [1]

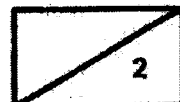

25. Study the characteristics of the animals that are classified in the table below.

| Group S | Group T |
|--|--------------------------------------|
| <p>frog</p> <p>legs</p> <p>lion</p> <p>tail</p> <p>leg</p> <p>tortoise</p> | <p>fish</p> <p>tail</p> <p>snake</p> |

(a) Give a suitable heading for the table above. [1]

Group S: _____

Group T: _____

(b) State one similarity between the characteristics of the fish and the tortoise. [1]

Adam regrouped the animals as shown in the table below.

| Group Y | Group Z |
|---------|-----------------------------------|
| lion | fish snake frog tortoise |

(c) State one difference between the characteristics of animals in Group Y and animals in Group Z. [1]

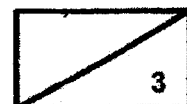

26. Study the chart below.

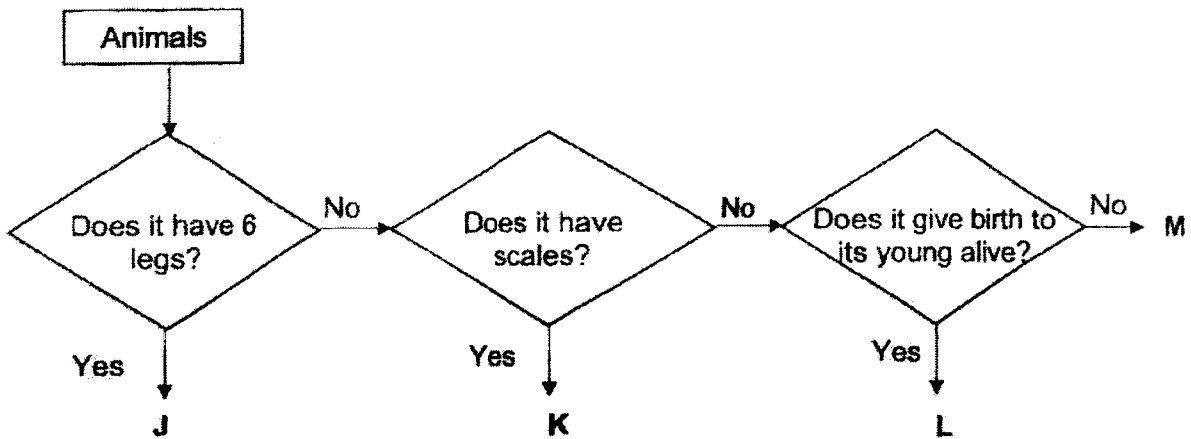

(a) Give ONE example of animal J. [1]

(b) Based only on the chart above, state all the characteristics of animal K. [1]

(c) State one difference between animals L and M. [1]

(d) Which animal group does animal M belong to? [1]

27. David conducted an experiment with four slices of bread. He wanted to find out how the amount of water affects the growth of bread mould. He recorded his observation in the table below.

| Set-ups | A | B | C | D |
|---|----|---|----|----|
| Amount of water added to bread (ml) | 0 | 5 | 10 | 15 |
| Number of days before mould appeared on bread | 11 | 6 | X | 2 |

- (a) State the number that can represent X in the table above. [1]

- (b) Based on the results above, state the relationship between the amount of water added to the bread and the number of days before the mould appeared. [1]

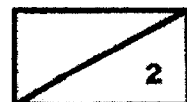

28. Study the diagram below.

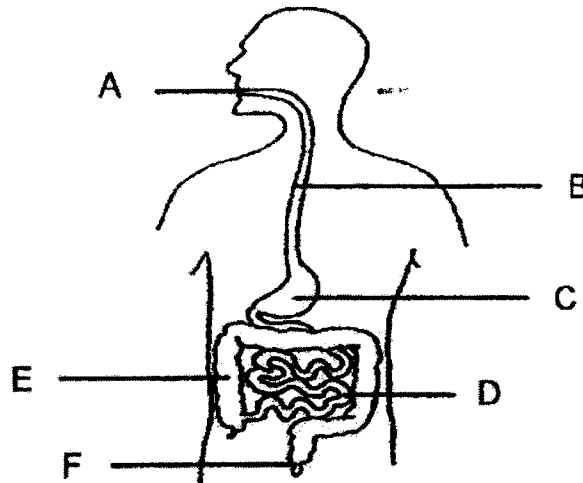

Three student made the following statements about the human digestive system shown above.

| Student | Statements |
|---------|--|
| Amy | Part A absorbs food. |
| Ben | Digestion of food continues and completes in part D. |
| Claire | The digestive juice produced in part C will mixed with the food. |

(a) (i) Which student had made a wrong statement about the digestive system?

(ii) Write down the correct statement based on the function of the part. [1]

(b) State the function of part E. [1]

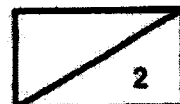

Kelly ate 70 units of food. The graph below shows the amount of food in different parts of her digestive system after it has been eaten.

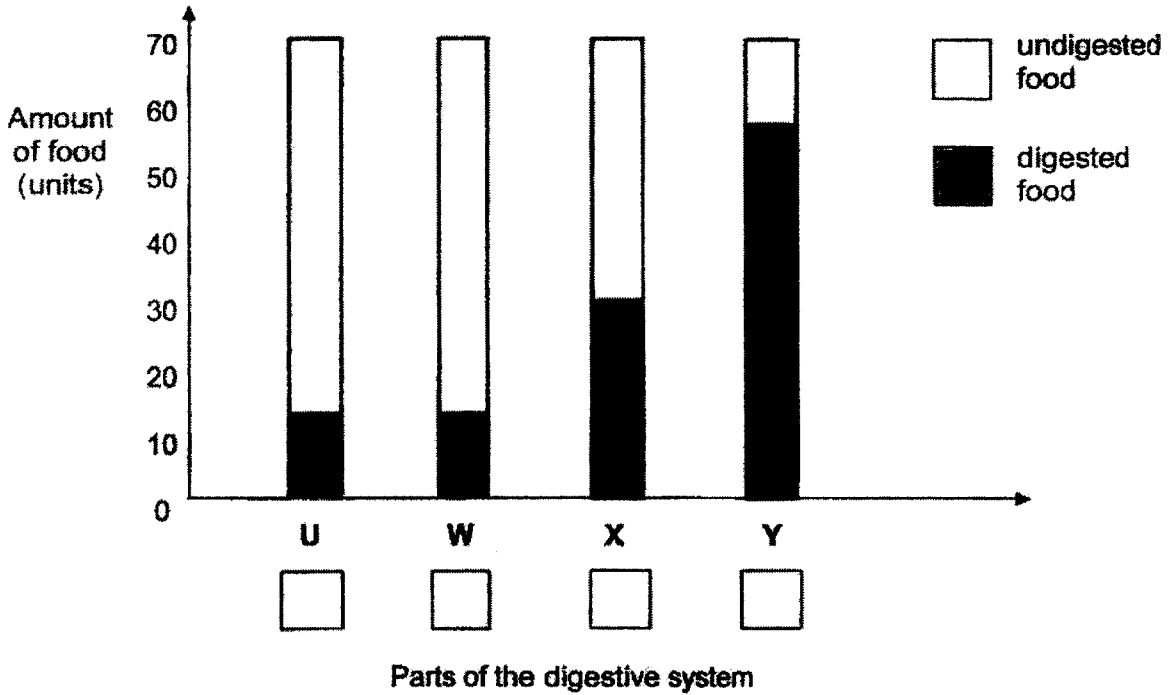

(c) Put a tick (✓) in the box that represents the small intestine. [1]

(d) Give a reason why the amount of digested food in part W is the same as part U. [1]



29. Joy wanted to find out which material, X or Y, would be more suitable for making poles to hang wet heavy clothes out to dry.

She secured 2 poles made of material X and Y on the wall. Joy then hung different weights on each pole one at a time until one of the poles broke, as shown in the diagram below.

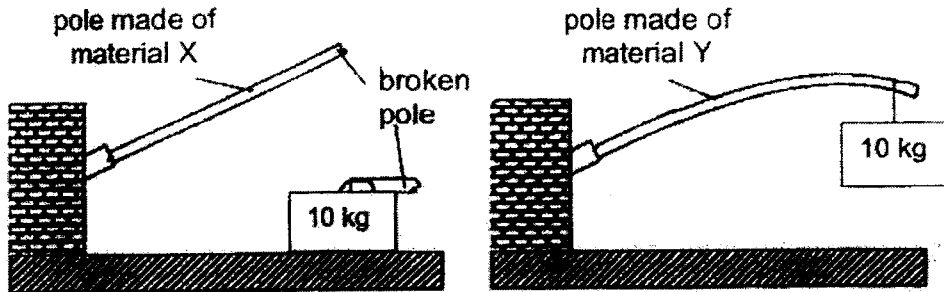

- (a) Based on the property shown in the experiment above, **explain** which material is more suitable for making poles to hang the heavy wet clothes. [2]

Using the same set-up, Joy also measured the bend of each pole when a 8-kg weight is hung. Both poles did not break. She recorded the results in the table below.

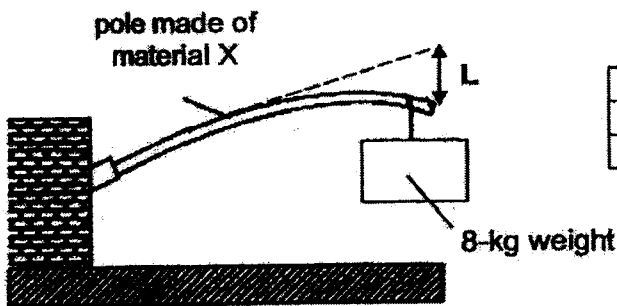

| Material | Length of L |
|----------|-------------|
| X | 6 cm |
| Y | 11 cm |

- (b) Compare the property of material X and Y based on the table above. [1]



30. The diagram below shows an experiment that Sara had set up. She raised the steel paper clip up close to the magnet before letting it go. The paper clip was "floating" in the air. The paper clip was attached to a 10 cm-string tied to a stone.

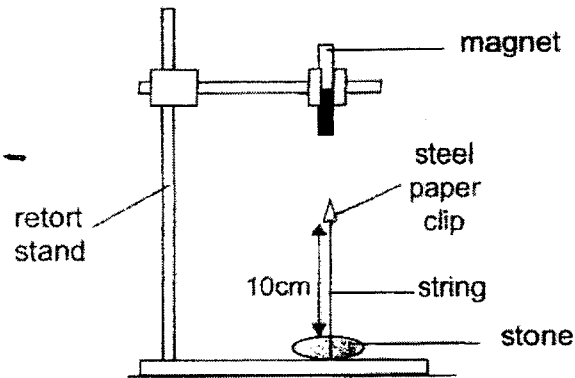

The magnet was then removed and heated over a flame for some time. Sara repeated the experiment after the magnet had cooled down.

- (a) State and explain the observation about the paper clip that Sara would make after she repeated the experiment with the cooled magnet. [2]

Observation : _____

Explanation : _____

Sara had a magnetic toy shark. The diagram below shows the position of the 2 magnets, X and Y, in the magnetic toy. When the tip of the toy shark was placed on the pivot of the plastic base, the toy shark will be suspended in the air. The pivot allows the tip of the shark to turn freely.

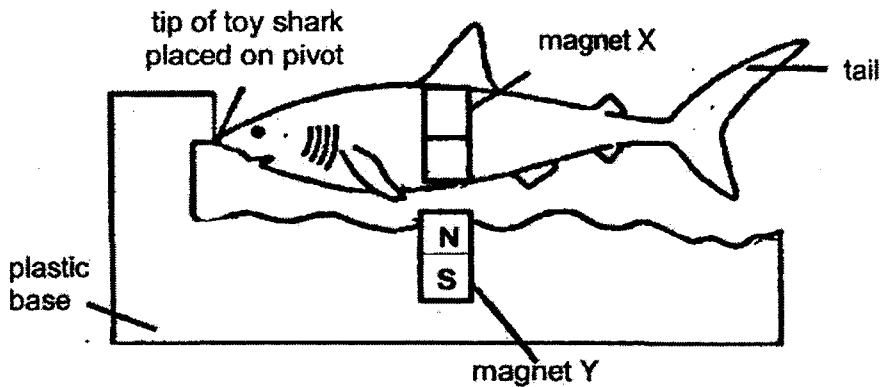

- (b) Write the letters, N and S, on magnet X in the diagram above to show the poles of the magnet. [1]

- (c) Which property of magnets allows the toy shark to be suspended in the air? [1]

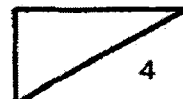

31. The diagram below shows part A and B of a set of door stopper.

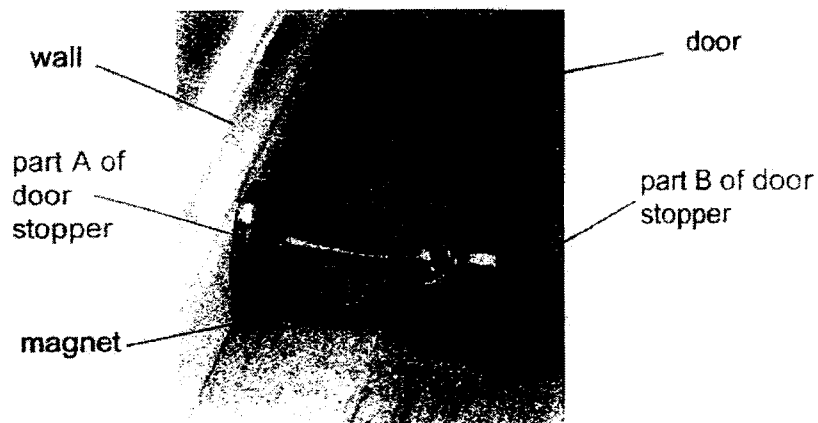

- (a) Name a material that part B of the door stopper can be made of. [1]

- (b) Explain how the set of door stopper works. [1]

~ END OF BOOKLET B ~

Nanyang Primary School
P3 SCIENCE EYE Practice Paper 2022
Answer Key

Section A

| | | | |
|----|---|---|---|
| 1 | 4 | 3 | 2 |
| 2 | 3 | 1 | 3 |
| 3 | 3 | 4 | 2 |
| 4 | 2 | 4 | 2 |
| 5 | 3 | 2 | 2 |
| 6 | 2 | 4 | 2 |
| 7 | 2 | 2 | 2 |
| 8 | 3 | 3 | 2 |
| 9 | 3 | 1 | 2 |
| 10 | 2 | 3 | 2 |

Section B

| Qn No | Answers |
|-------|---|
| 23a. | She should provide <u>water</u> . |
| 23b. | It is to allow <u>air to enter</u> as her pet needs air to <u>stay/alive</u> . |
| 24a. | <pre> graph TD Plants --> Flowering Plants --> Non-flowering Flowering --> OnLand1[On land] Flowering --> OnWater1[On water] Non-flowering --> OnLand2[On land] Non-flowering --> OnWater2[On water] OnLand1 --- D OnWater1 --- B OnLand2 --- A OnWater2 --- C </pre> |
| 24b. | The plant bears fruits so it must be a flowering plant. Only flowering plants can bear fruits. |
| 25a. | Group S: Animals with (4) legs Group T: Animals with no legs |
| 25b. | Both have <u>scales</u> . |
| 25c. | Group Y give birth to young alive but Group Z does not give birth to young alive. |

| | |
|------|---|
| 26a. | Any insect |
| 26b. | Animal K has scales and does not have 6 legs. |
| 26c. | Animal L gives birth to its young alive but animal M lays eggs. |
| 26d. | Amphibians/Birds |
| 27a. | 3, 4 or 5 (a range of values are accepted) |
| 27b. | The more amount of water added, the fewer number of days before the mould appear. |
| 28a. | Both the young of B and C do not resemble the adults. (Replacement Qn) |
| 28b. | B lays eggs in water but B does not lay eggs in water. |
| 28c. | <pre> graph TD Adult --> Egg Egg --> nymphyoung[nymph/young] nymphyoung --> Adult </pre> |
| 29a. | Material Y, it is stronger (P) so the pole can hold the wet, heavy clothes without breaking (F) |
| b. | Material Y is more flexible. |
| 30. | Observation: The steel paper clip will drop down/ will not float in the air. |
| a. | Explanation: The magnet will lose some magnetism after it is being heated and will be too weak to attract the steel paper clip from the same distance. |
| b. | <div style="border: 1px solid black; padding: 5px; display: inline-block; text-align: center;"> <p>S</p> <p>N</p> </div> |
| c. | Like poles of magnets facing each other will repel. |
| 31a. | Steel/ Iron |
| b. | Magnet on part A will attract the magnetic metal on part B. |