



CATHOLIC HIGH SCHOOL
SEMESTRAL ASSESSMENT TWO (2018)
PRIMARY THREE
SCIENCE
BOOKLET A

Name: _____ ()

Class: Primary 3 - _____

Date: 31 October 2018

24 questions

48 marks

Total Time for Booklets A and B: 1 hour 30 minutes

INSTRUCTIONS TO CANDIDATES

Do not turn over this page until you are told to do so.

Follow all instructions carefully.

Answer all questions.

Shade your answers in the Optical Answer Sheet (OAS) provided.

This booklet consists of 14 printed pages, excluding the cover page.

Booklet A (24 × 2 marks)

For each question from 1 to 24, four options are given. One of them is the correct answer. Make your choice (1, 2, 3 or 4). Shade your answer on the Optical Answer Sheet. (48 marks)

1 Which one of the following is a characteristic of all living things?

- (1) They feed on plants.
- (2) They need sunlight to grow.
- (3) They can grow from young to adult.
- (4) They reproduce by giving birth to young.

2 May put three grasshoppers and a dish of water in a glass jar. She used a sheet of clear plastic with some tiny holes to cover the jar as shown below. After a week, all the grasshoppers died.

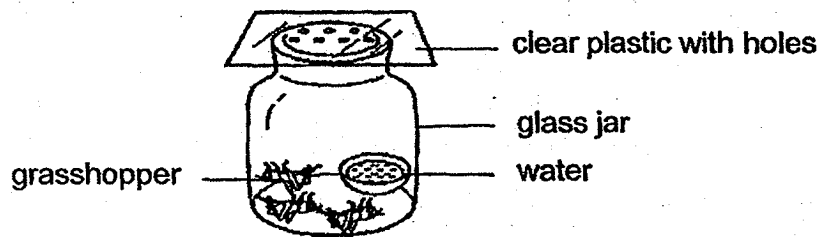

What could May have done so that the grasshoppers would stay alive?

- (1) Put some grass into the jar.
- (2) Take out two grasshoppers.
- (3) Place the jar in an open field.
- (4) Put some moist soil into the jar.

3 James classified some plants as shown below.

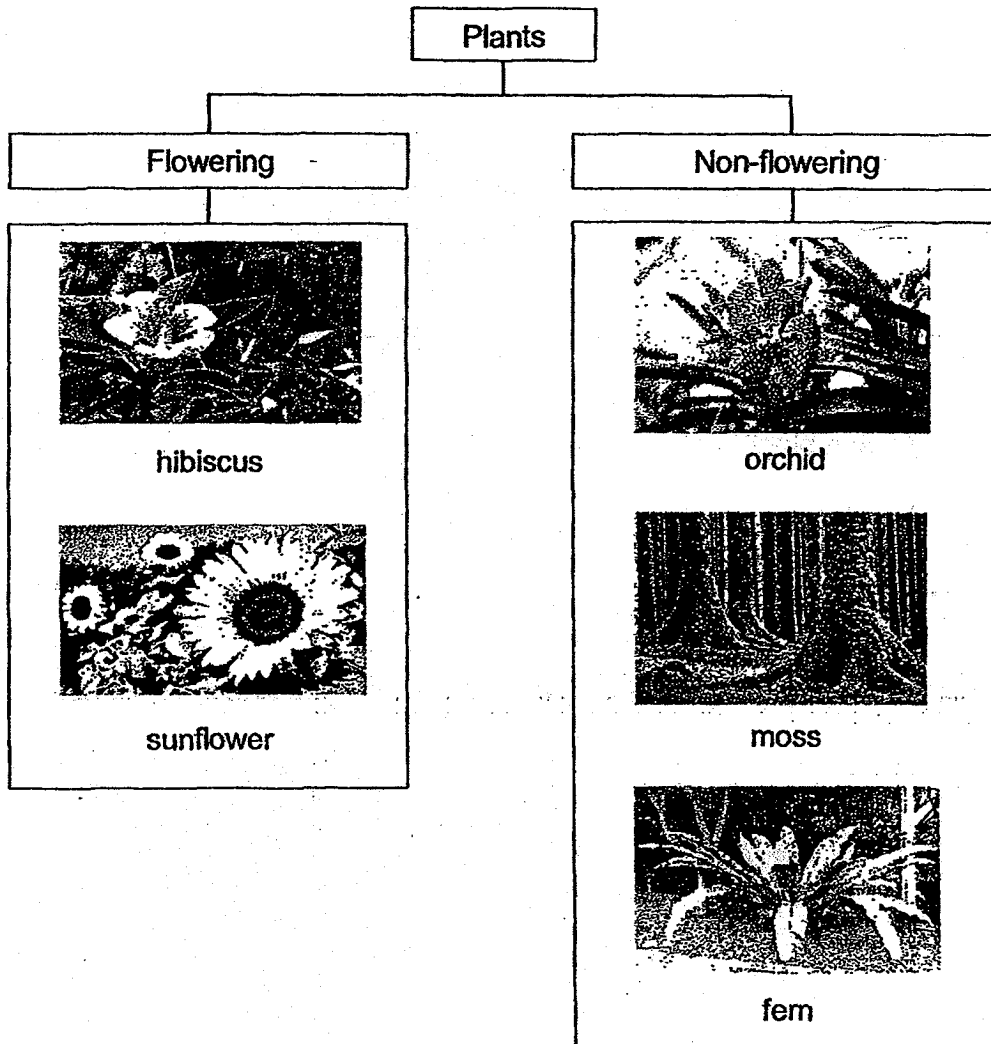

Which plant is not classified correctly?

- (1) fern
- (2) orchid
- (3) hibiscus
- (4) sunflower

4 Study the chart below.

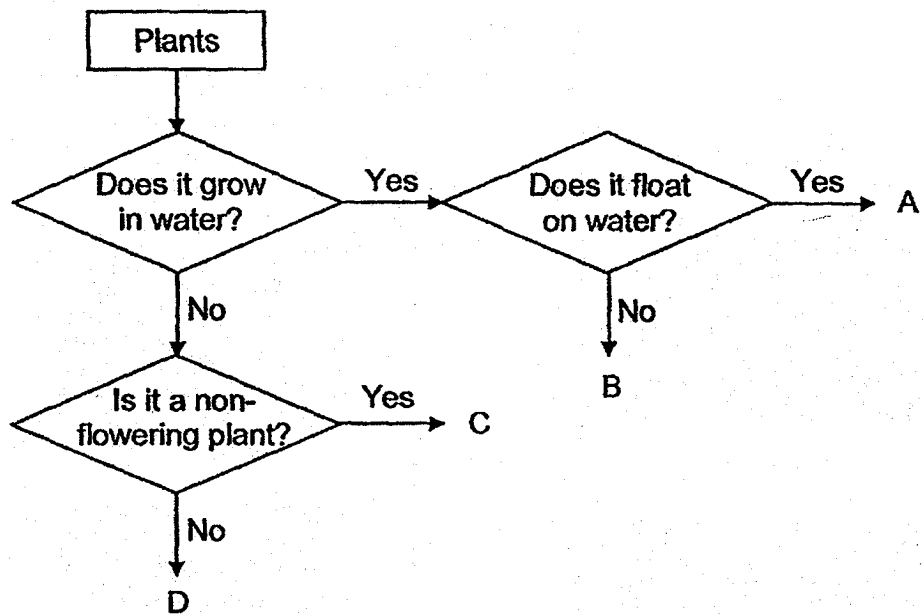

Which letters, A, B, C or D, represent the water hyacinth and the rose plant?

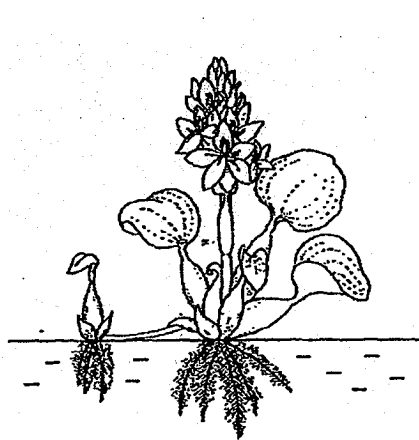

water hyacinth

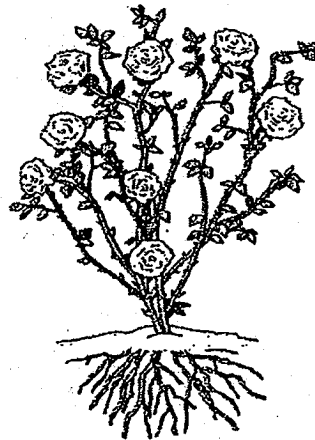

rose plant

	water hyacinth	rose plant
(1)	A	C
(2)	A	D
(3)	B	C
(4)	B	D

5 Study the chart below.

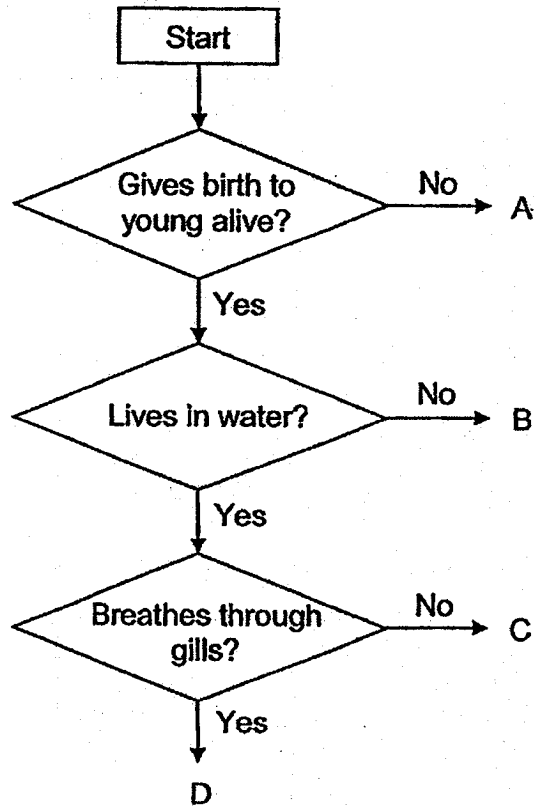

Animal Z is a sea mammal. Which letter, A, B, C or D, best represents animal Z?

- (1) A
- (2) B
- (3) C
- (4) D

6 Study the chart below.

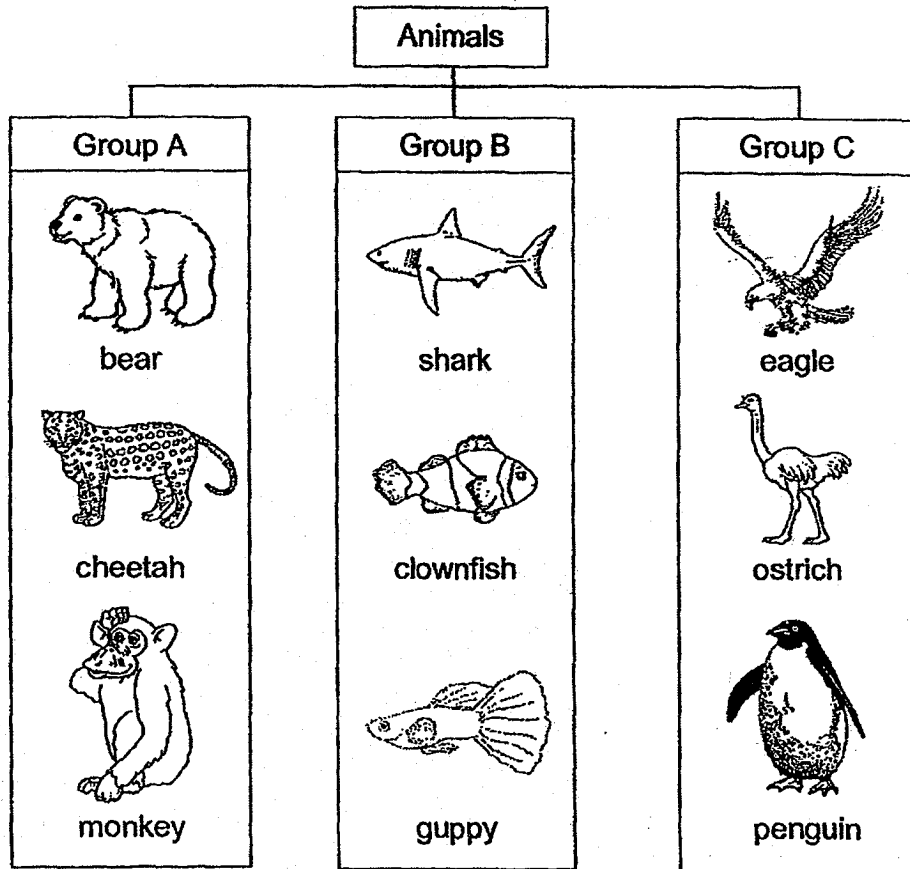

How are the above animals grouped?

- (1) The way they move
- (2) The place they live in
- (3) The type of food they eat
- (4) The type of outer covering they have

7 Four pupils found some living things growing on a rotting log.



They made the following statements about the living things.

Name of pupil	Statements
Anton	They are plants.
Bala	They do not need sunlight.
Chee Ming	They are able to make their own food.
Dalimah	They reproduce by spores.

Who are correct?

- (1) Bala and Dalimah only
- (2) Anton and Dalimah only
- (3) Bala and Chee Ming only
- (4) Anton and Chee Ming only

8 Which one of the following statements about bacteria is not correct?

- (1) Bacteria are microorganisms.
- (2) Bacteria do not need air or water to grow.
- (3) Bacteria feed on living things, dead or alive.
- (4) Bacteria can be useful and harmful to living things.

- 9 The diagram below shows the human skeletal system.

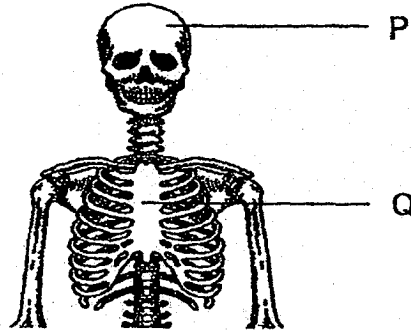

Which one of the following statements is correct about P and Q?

- (1) They allow us to stand upright.
 - (2) They protect the organs in our body.
 - (3) They work on their own to enable movement.
 - (4) They work together with the muscles to enable movement.
- 10 Danny went jogging one morning. He started breathing faster and his heart beat faster.

Which systems in his body were responsible for the changes that he experienced?

- (1) skeletal and muscular systems
- (2) circulatory and skeletal systems
- (3) respiratory and muscular systems
- (4) circulatory and respiratory systems

11 The diagram below shows a human body system.

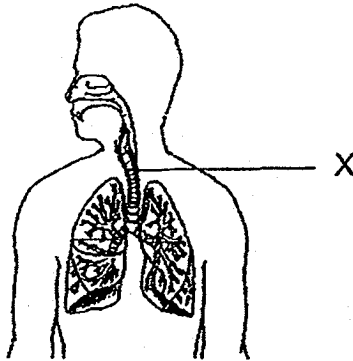

What is the part labelled X?

- (1) lung
- (2) gullet
- (3) windpipe
- (4) small intestine

12 The bar graph below shows the amount of digested and undigested food in five organs, A, B, C, D and E, of the digestive system over four hours.

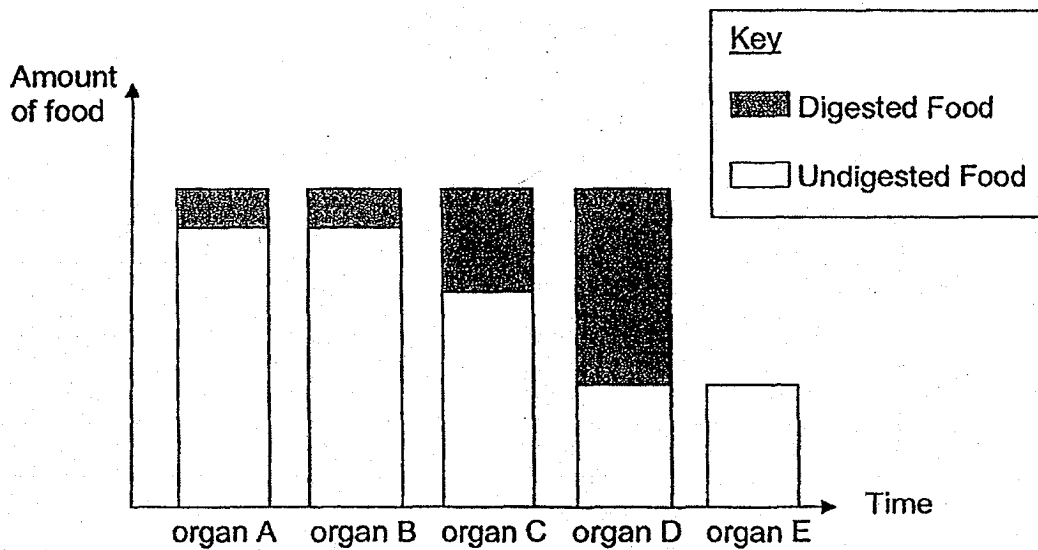

Which one of the following is most likely represented by organ E?

- (1) gullet
- (2) mouth
- (3) large intestine
- (4) small intestine

13 Which one of the following helps to hold the plant upright?

- (1) stem
- (2) roots
- (3) fruits
- (4) leaves

14 Study the diagram below.

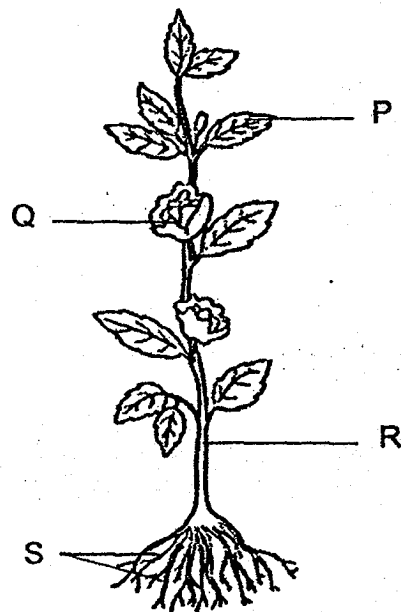

Which one of the following matches the parts correctly?

	P	Q	R	S
(1)	roots	stem	flower	leaf
(2)	flower	leaf	stem	roots
(3)	stem	flower	roots	leaf
(4)	leaf	flower	stem	roots

15 During a heavy rain with severe thunderstorm, which plant is most likely to be uprooted first?

(1)

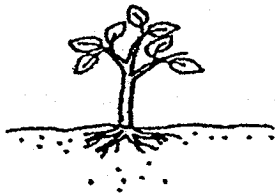

(2)

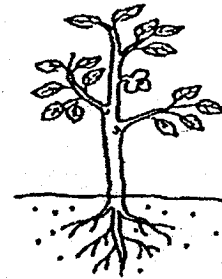

(3)

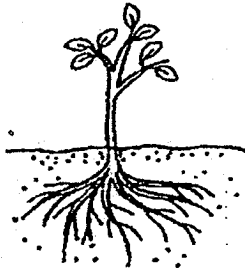

(4)

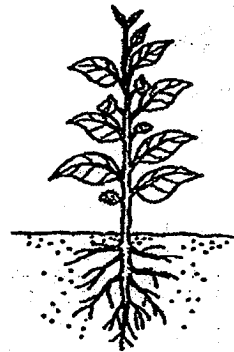

16 Study the chart below.

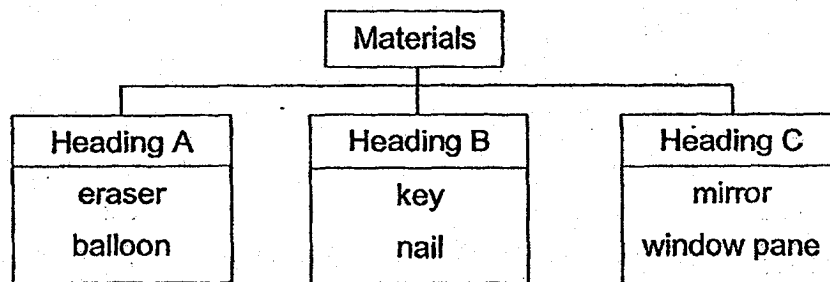

Which one of the following correctly shows what headings, A, B and C, can be?

	A	B	C
(1)	rubber	ceramic	glass
(2)	plastic	metal	fabric
(3)	rubber	metal	glass
(4)	plastic	ceramic	fabric

17 The diagram below shows a tennis racket.

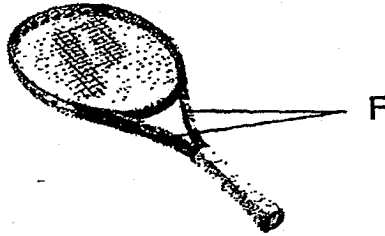

Which material is most suitable for making part F of the tennis racket?

- (1) glass
- (2) metal
- (3) rubber
- (4) ceramic

18 The table below shows the properties of four materials, P, Q, R and S. A tick (✓) indicates the presence of the characteristic.

Material \ Property	P	Q	R	S
Flexible	✓		✓	
Breaks easily.			✓	
Waterproof	✓	✓		✓
Can see through				✓

Which material is most suitable for making a raincoat?

- (1) P
- (2) Q
- (3) R
- (4) S

19 In which direction will a freely suspended magnet point to when it comes to rest?

- (1) South-East
- (2) North-West
- (3) South-West
- (4) North-South

20 The diagram below shows a horseshoe magnet.

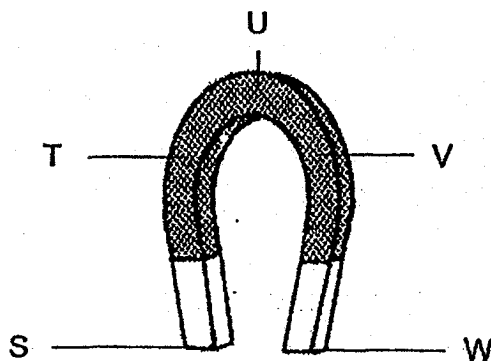

Which part(s) of the horseshoe magnet can attract the most number of paper clips?

- (1) U only
- (2) T and V only
- (3) S and W only
- (4) T, U and V only

- 21 Max set up an experiment and found that objects A and B were pulled towards magnet X as shown in the diagram below.

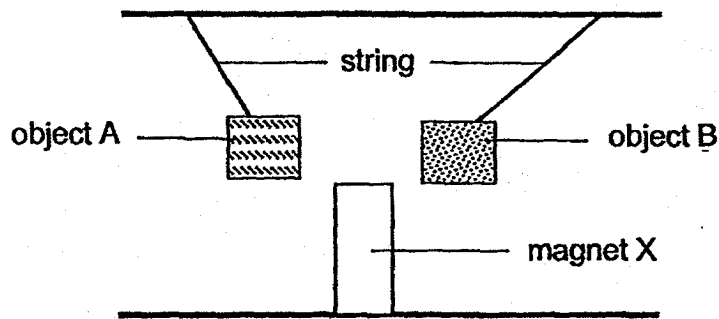

Which one of the following statements about objects A and B is correct?

- (1) Object A is a magnet but object B is non-magnetic.
 - (2) Object B is a magnet but object A is non-magnetic.
 - (3) Both objects A and B are made of magnetic materials.
 - (4) Object A is made of aluminium and object B is made of copper.
- 22 Four bar magnets are arranged as shown below.

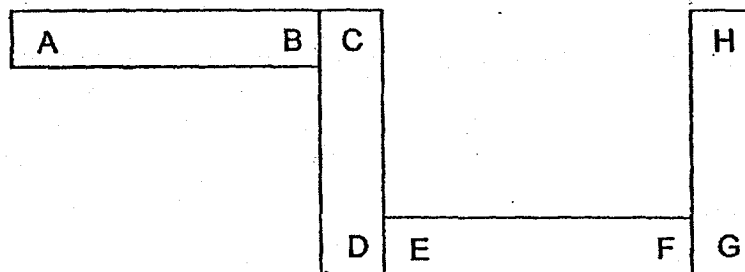

Which one of the following shows the correct arrangement when two of the bar magnets are put together?

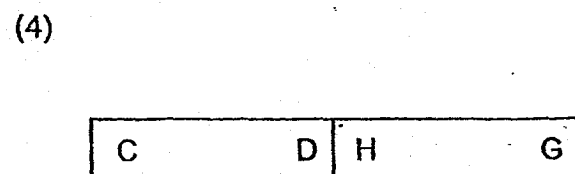
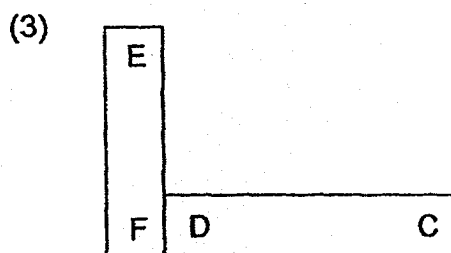
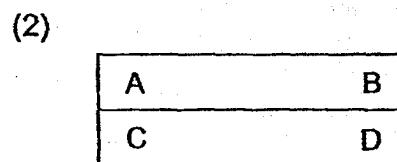
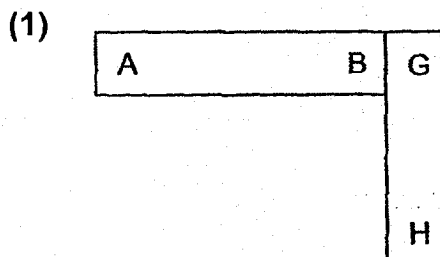

- 23 Peter wanted to magnetise an iron nail using the stroking method as shown below.

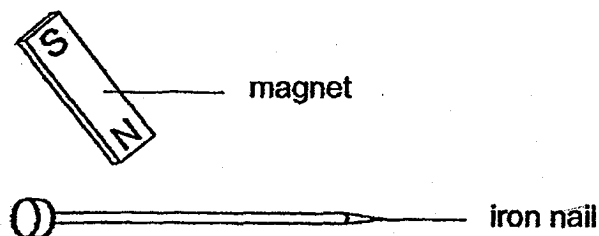

While stroking the iron nail, he should _____.

- A stroke the nail with the same pole of the magnet
- B stroke the nail with a magnet in different directions
- C stroke the whole length of the nail at least 20 times
- D stroke only part of the nail with a magnet in different directions

- (1) B only
- (2) A and C only
- (3) B and D only
- (4) A, C and D only

- 24 Four identical iron nails, W, X, Y and Z, were made into magnets using the stroking method. The table below shows the number of paper clips attracted.

Nails	W	X	Y	Z
Number of paper clips attracted	2	5	4	7

Which nail was stroked the most number of times?

- (1) W
- (2) X
- (3) Y
- (4) Z

End of Booklet A

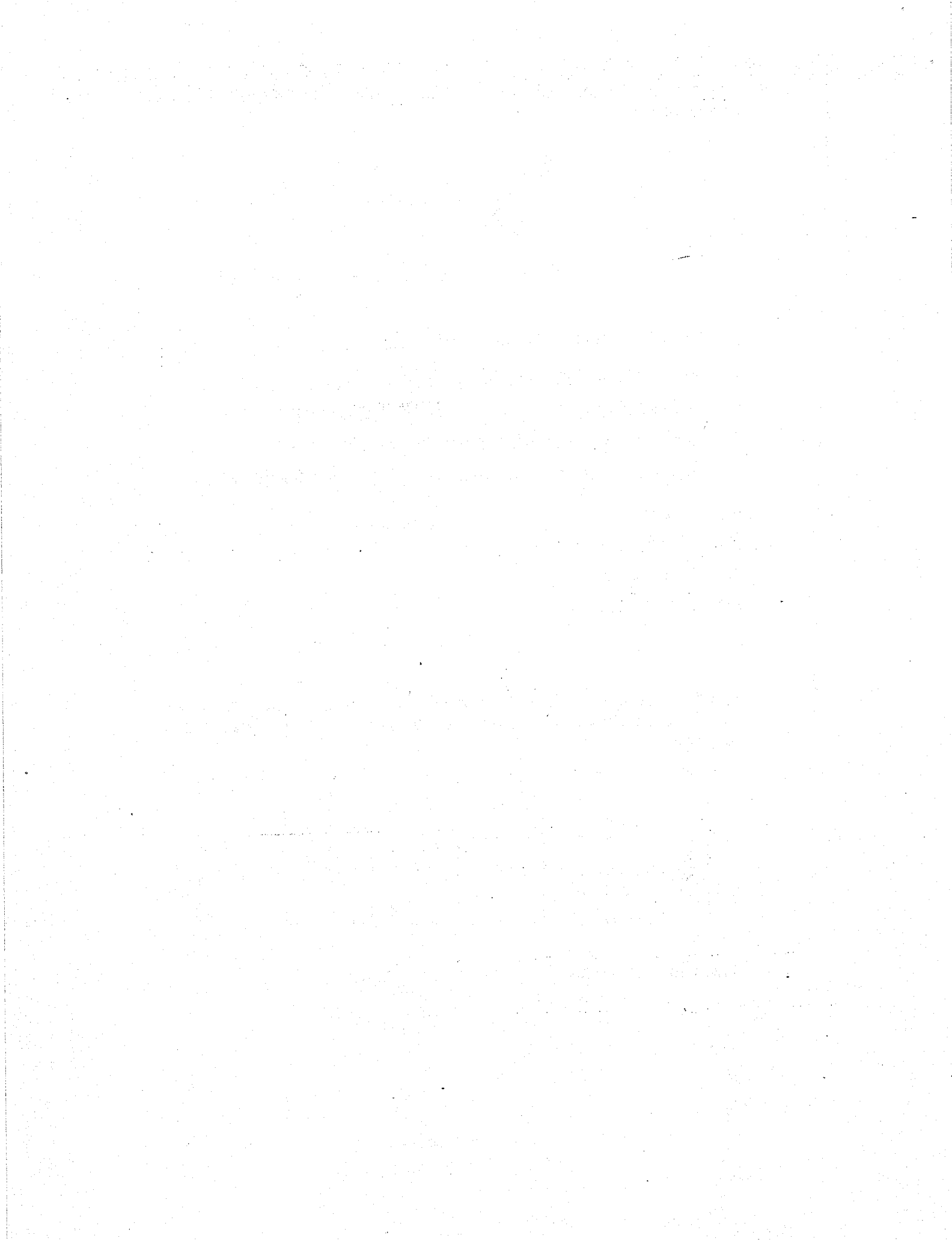

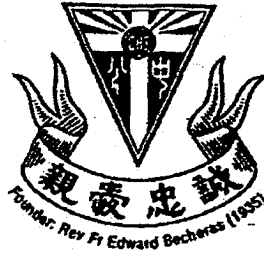

CATHOLIC HIGH SCHOOL

SEMESTRAL ASSESSMENT TWO (2018)

PRIMARY THREE

SCIENCE

BOOKLET B

Name: _____ ()

Class: Primary 3 - _____

Date: 31 October 2018

Parent's Signature: _____

Booklet A	48
Booklet B	32
Total	80

10 questions

32 marks

Total Time for Booklets A and B: 1 hour 30 minutes

INSTRUCTIONS TO CANDIDATES

Do not turn over this page until you are told to do so.

Follow all instructions carefully.

Answer all questions.

Write your answers in this booklet.

This booklet consists of 10 printed pages, excluding the cover page.

Booklet B (32 marks)

For questions 25 to 34, write your answers in this booklet.

The number of marks available is shown in brackets [] at the end of each question or part question. (32 marks)

25 Ken observed a pair of mice in a cage for a month.

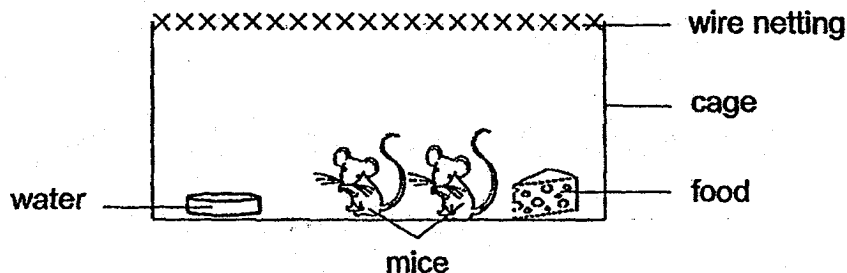

(a) Match Ken's observations to the characteristics of living things. [2]

Observations

- The mice fed on the food and water.
- The mice were bigger in size after two weeks.
- The mice ran around the cage when Ken moved the cage.
- There were more mice in the cage after one month.

Characteristics of living things

- Living things can grow.
- Living things need food and water.
- Living things can reproduce.
- Living things respond to changes around them.

Ken then replaced the wire netting with a piece of cardboard.

(b) What would Ken observe after a week? [1]

(c) Explain your answer in (b). [1]

(Go on to the next page)

SCORE	4
-------	---

26 Study the two plants below.

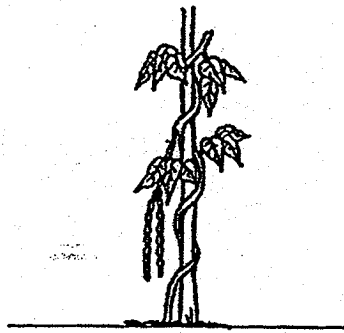

plant X



plant Y

- (a) Based on the diagram above, state one similarity and one difference between plant X and plant Y.
(Do not compare size, shape and colour.)

(i) Similarity: [1]

(ii) Difference: [1]

- (b) Based on the diagram above, are plant X and plant Y flowering plants?
Give a reason for your answer. [1]

(Go on to the next page)

SCORE	3
-------	---

27 Study the chart below.

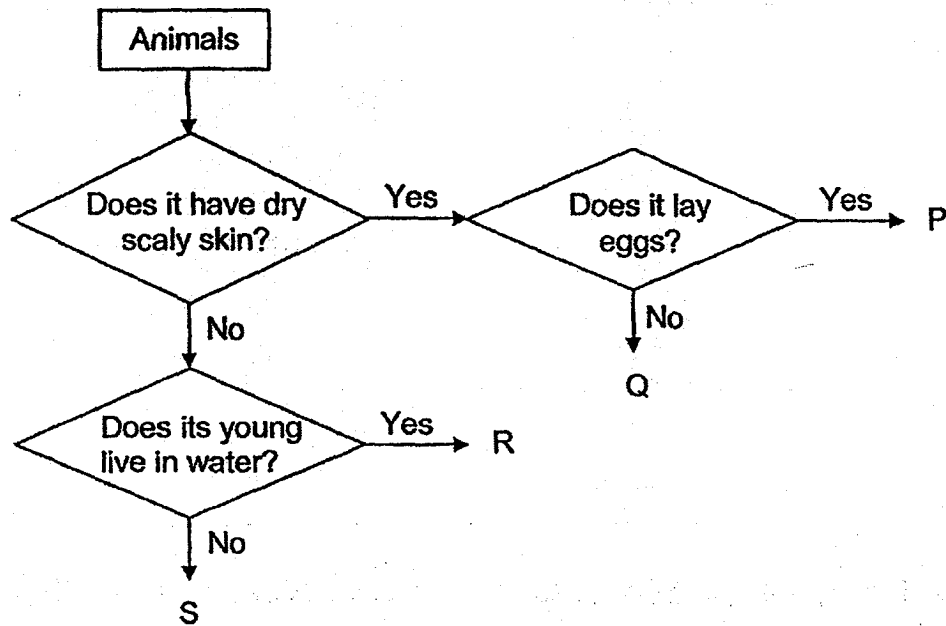

(a) Based on the chart above, state two characteristics of animal Q. [1]

(b) Based on the chart above, state one similarity between animals R and S. [1]

(c) Based on the chart above, which animal, P, Q, R or S, is most likely to be a snake? [1]

(Go on to the next page)

SCORE	3
-------	---

- 28 Mei Ling wanted to find out the temperature at which mould grows best on cupcakes. She placed five identical cupcakes each into four similar plastic containers, W, X, Y and Z. Each container was placed in a different room at a different temperature for one week.

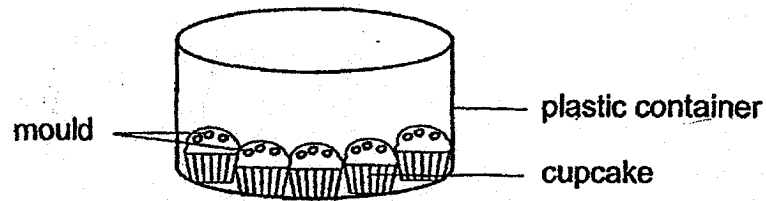

She recorded her results in the table as shown below.

Plastic container	Temperature of the room the container was placed in ($^{\circ}\text{C}$)	Number of cupcakes with mould growing on them
W	10	1
X	15	3
Y	25	4
Z	30	5

- (a) Based on the results above, what change do you notice about the number of cupcakes with mould growing on them as the temperature of the room increased? [1]

- (b) Based on the experiment above, name the condition that affected the growth of the mould. [1]

(Go on to the next page)

SCORE	
-------	--

29 · The diagram below shows the human digestive system.

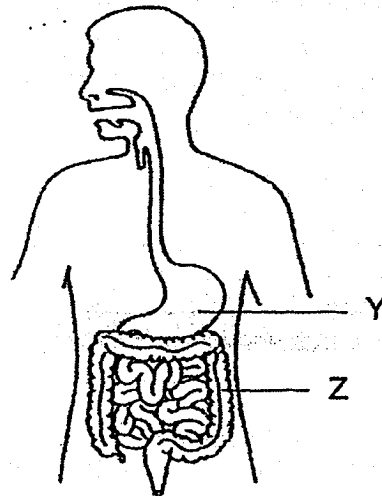

(a) Name the labelled parts of the human digestive system. [1]

Part Y: _____

Part Z: _____

(b) What happens at part Z? [1]

(Go on to the next page)

SCORE	2
-------	---

30 Study the chart below. It shows the parts of a plant and their functions.

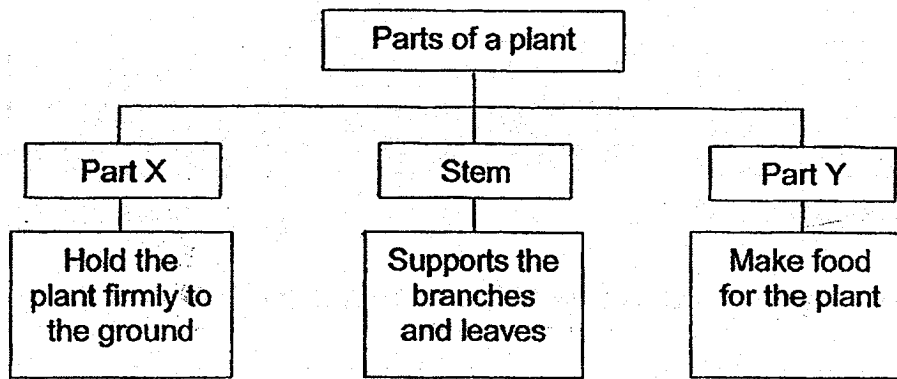

(a) Name parts X and Y. [2]

Part X: _____

Part Y: _____

(b) State another function of part X. [1]

(Go on to the next page)

SCORE	3
-------	---

32 Ahmad arranged three ring magnets through a plastic rod as shown in diagram 1 below.

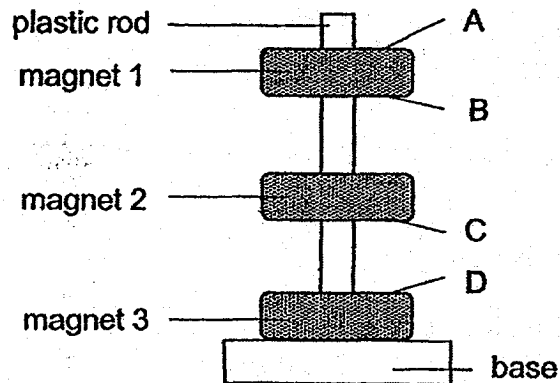

diagram 1

(a) Identify the poles of the ring magnets indicated by A, B, C and D. [2]

A: _____ C: _____

B: _____ D: _____

(b) State a property of the magnets shown in the diagram above. [1]

Ahmad made a change to one of the magnets such that the three ring magnets come together as shown in diagram 2.

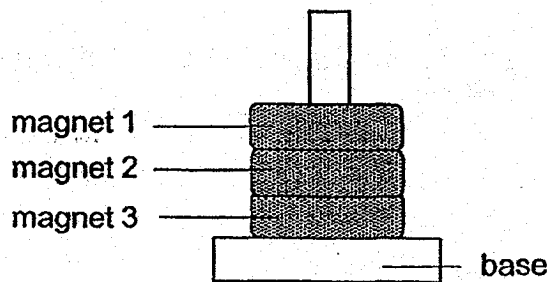

diagram 2

(c) What was the change that Ahmad had made? [1]

(Go on to the next page)

SCORE	4
-------	---

- 33 Ben wanted to magnetise an iron nail using the stroking method as shown in the diagram below.

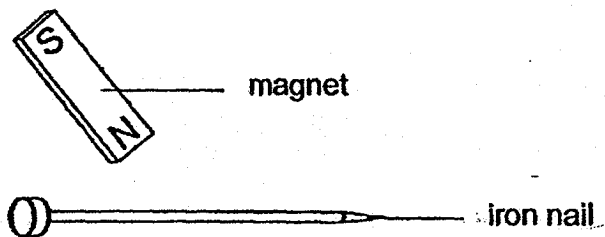

The table below shows his results.

Number of times the iron nail is stroked	Number of paper clips attracted
10	1
20	2
30	3

- (a) Put a tick (✓) in the box(es) below to indicate the minimum number of times the iron nail is stroked to attract 4 paper clips. [1]

Number of times the iron nail is stroked	Tick (✓)
25	
30	
40	

Ben changed the iron nail to a plastic ruler.

- (b) How many paper clips could the plastic ruler attract after he stroked it 40 times with the magnet? [1]

- (c) Give a reason for your answer in (b). [1]

(Go on to the next page)

SCORE	3
-------	---

34 Mabel set up the following experiment as shown below.

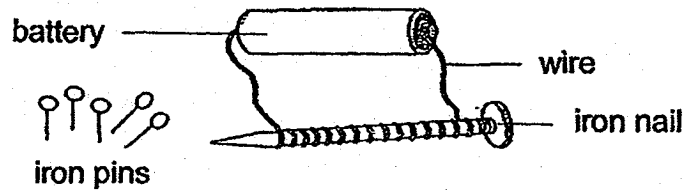

(a) What did Mabel observe when she placed some iron pins near the iron nail? [1]

(b) Give a reason for your answer in (a). [1]

(c) Suggest one way for Mabel to attract more iron pins to the iron nail. [1]

The crane below is found at a metal scrapyards. A magnet is attached to one end of the crane.

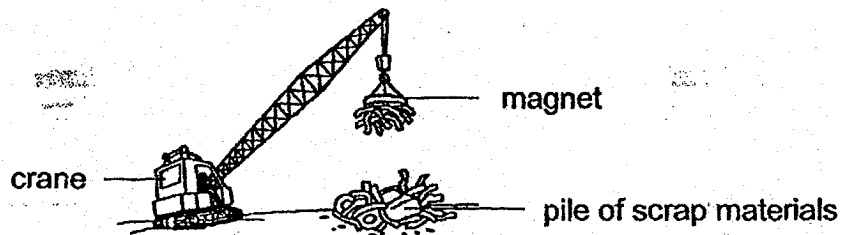

(d) Explain how the magnet helps to separate the magnetic materials from the pile of scrap materials. [1]

End of Booklet B

SCORE	4
-------	---

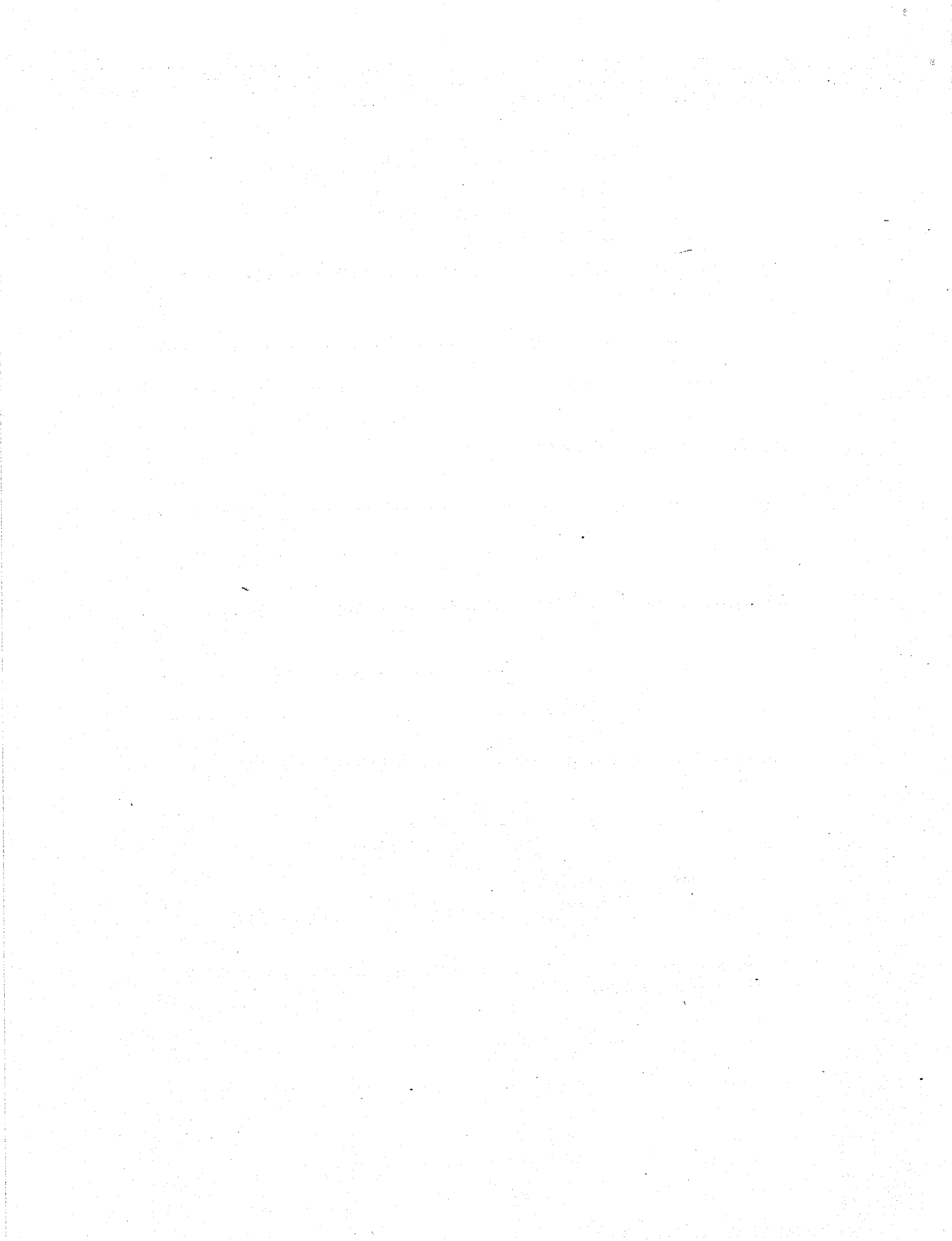

EXAM PAPER 2018 (P3)

SCHOOL : CATHOLIC HIGH

SUBJECT : SCIENCE

TERM : SA2

Q1	Q2	Q3	Q4	Q5	Q6	Q7	Q8	Q9	Q10
3	1	2	2	3	4	1	2	2	4
Q11	Q12	Q13	Q14	Q15	Q16	Q17	Q18	Q19	Q20
3	3	1	4	1	3	2	1	4	3
Q21	Q22	Q23	Q24						
3	1	2	4						

Q25) a)

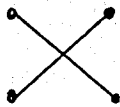
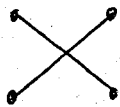

b) The mice died

c) Air could not enter the cage and living things need air to survive.

Q26) a) i) They are land plants

ii) Plant X has a weak stem while plant Y has a strong stem.

b) Yes. Both plants have fruits.

Q27) a) Animal Q has dry scaly skin and does not lay eggs.

b) They do not have dry scaly skin.

c) P

Q28) a) As the temperature of the room increased, the number of would growing on them increased.

b) warmth

Q29) a) Part Y : stomach

Part Z : large intestine

b) Water will be absorbed from the undigested food.

Q30) a) Part X : roots

Part Y : leaves

b) Absorb water and mineral salts from the soil

Q31) a) type of material

b) Z , X , Y

c) Z. It is the strongest material as it can withstand the weight of 60kg.

Q32) a) A : North B : South C : North D : North

b) Like poles repel

c) He flipped magnet 2 over

Q33) a) 40

b) Zero

c) It is because it is a non-magnetic material.

Q34) a) The iron nail attract the iron pins.

b) It is because a magnet can attract magnetic material.

c) She should coil more wires around the iron nail to attract more iron pins

d) It is because the magnet can attract magnetic materials but not non-magnetic material.

