

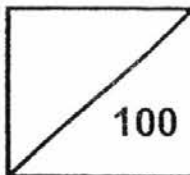

**Rosyth School**  
**Second Semestral Assessment 2016**  
**Mathematics**  
**Primary 4**

Total 

Name: \_\_\_\_\_

Class: Pr 4 - \_\_\_\_\_ Register No. \_\_\_\_\_ Duration: 1 h 45 min

Date: 24 October 2016 Parent's Signature: \_\_\_\_\_

---

**Instructions to Pupils:**

1. Do not open this booklet until you are told to do so.
2. Follow all instructions carefully.
3. This paper consists of 3 parts, Sections A, B and C.
4. For questions 1 to 20 in Section A, shade the correct ovals on the Optical Answer Sheet (OAS).
5. ANSWER ALL THE QUESTIONS.

	<b>Maximum</b>	<b>Marks Obtained</b>
<b>Section A</b>	<b>40</b>	
<b>Section B</b>	<b>40</b>	
<b>Section C</b>	<b>20</b>	
<b>Total</b>	<b>100</b>	

\* This paper consists of 23 printed pages altogether.

### Section A

For questions 1 to 20, four options are given. One of them is the correct answer. Make your choice (1, 2, 3 or 4). Shade the correct ovals (1, 2, 3 or 4) onto the Optical Answer Sheet provided. Each question carries 2 marks.

(40 marks)

1. In which of the following numbers does the digit 4 stand for 4000?

(1) 2496

(2) 4962

(3) 6249

(4) 9624

2. 35 479 rounded off to the nearest hundred is \_\_\_\_\_.

(1) 35 000

(2) 35 400

(3) 35 480

(4) 35 500

3. Which of the following is a factor of both 24 and 30?

(1) 5

(2) 6

(3) 8

(4) 4

4. The figure shown is made up of identical squares.

What fraction of the figure is shaded?

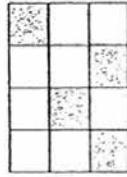

- (1)  $\frac{4}{8}$
- (2)  $\frac{4}{10}$
- (3)  $\frac{4}{12}$
- (4)  $\frac{8}{12}$
5. Which of the following is **not** an equivalent fraction of  $\frac{1}{4}$ ?
- (1)  $\frac{2}{8}$
- (2)  $\frac{3}{12}$
- (3)  $\frac{6}{24}$
- (4)  $\frac{4}{20}$

6. Which of the following decimals is the greatest?
- (1) 0.369
  - (2) 0.048
  - (3) 0.359
  - (4) 0.297
7. Andrew and Cayden sold some lollipops at a fun fair. Andrew sold 1498 lollipops. Cayden sold 268 fewer lollipops than Andrew. How many lollipops did they sell altogether?
- (1) 1230
  - (2) 1766
  - (3) 2728
  - (4) 3264
8. The total cost of a dining table and 4 chairs is \$1085. The dining table costs 3 times as much as a chair. Find the cost of the dining table.
- (1) \$155
  - (2) \$217
  - (3) \$465
  - (4) \$771

9. Mrs Lee baked an equal number of cookies and cupcakes at first. After she sold 23 cookies and 147 cupcakes, she had 3 times as many cookies as cupcakes. How many cupcakes did she bake at first?

- (1) 62
- (2) 85
- (3) 209
- (4) 232

10. The figure below is made up of a square ABCD and a rectangle EFGH.

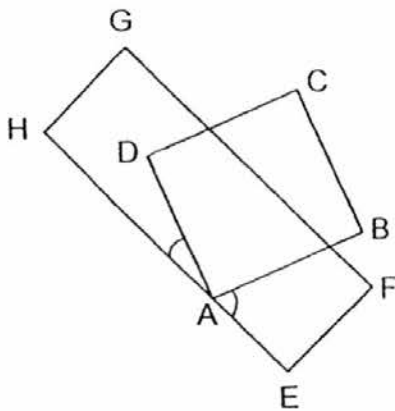

Find the sum of  $\angle DAC$  and  $\angle FGH$  and  $\angle DAI$  and  $\angle BAE$ .

- (1)  $45^\circ$
- (2)  $90^\circ$
- (3)  $135^\circ$
- (4)  $180^\circ$

11. Andy is now facing South-west after turning  $270^\circ$  anti-clockwise. What direction was he facing at first?

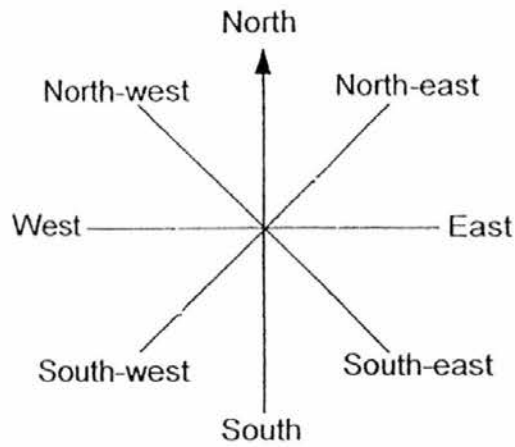

- (1) North  
(2) North-west  
(3) East  
(4) South-east
12. The figure below is made up of 3 squares.  
How many right angles are there in the figure?

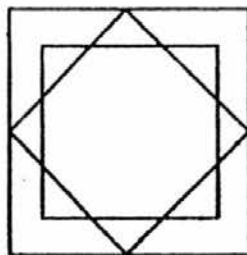

- (1) 8  
(2) 12  
(3) 16  
(4) 20

13. Which of the following dotted lines, A, B, C or D, is a line of symmetry?

(1)



(2)

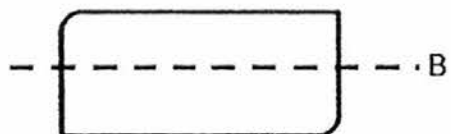

(3)

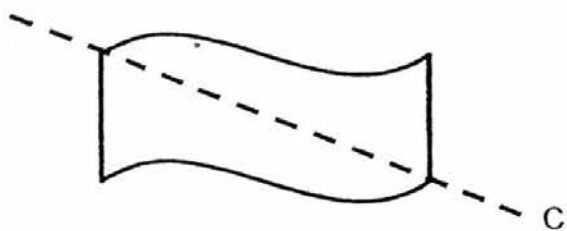

(4)

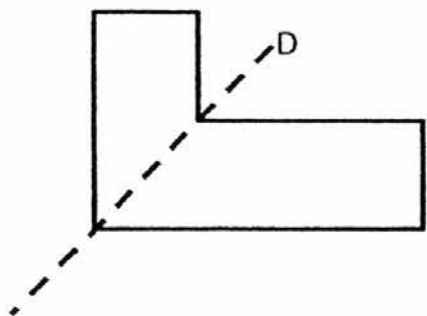

Please refer to the table below for questions 14 and 15.

The table below shows the number of boys and girls participating in certain games during Sports Day.

Game	Number of Boys	Number of Girls
Badminton	38	40
Captain's Ball	42	33
Soccer	32	37
Softball	39	38

14. Which game has the most number of participants?
- (1) Badminton
  - (2) Captain's Ball
  - (3) Soccer
  - (4) Softball
15. How many more boys than girls are there during the Sports Day?
- (1) 1
  - (2) 2
  - (3) 3
  - (4) 4



16. Find the perimeter of the figure shown below.

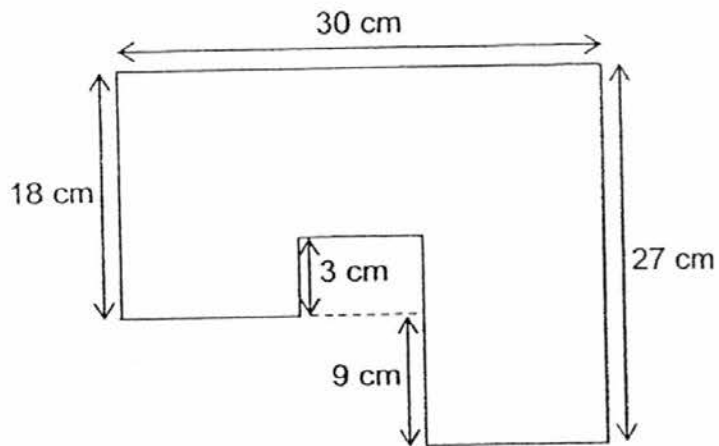

- (1) 87 cm
- (2) 90 cm
- (3) 114 cm
- (4) 120 cm

17. Mrs Tan bought 8 kg of grapes at \$6.35 per kg. How much did she spend altogether?

- (1) \$50.00
- (2) \$50.70
- (3) \$50.80
- (4) \$51.10

18. Mdm Wakil bought 12.4 m of cloth to make a blouse and a skirt. She used 3.6 m of it for the blouse. She used 2.8 m more cloth for the skirt than for the blouse. How much cloth had she left?
- (1) 2.4 m
  - (2) 2.5 m
  - (3) 6 m
  - (4) 10 m
19. Stall A sells prawns at \$2.40 for every 100 g. Stall B sells 100 g of prawns at \$0.60 less than Stall A. How much will Mrs Hong spend if she buys 500 g of prawns from Stall B?
- (1) \$8.00
  - (2) \$9.00
  - (3) \$12
  - (4) \$15.00
20. James' violin lesson was supposed to start at 5.15 p.m. His teacher started the lesson 25 minutes late. James' violin lesson lasted 1 h 30 min. What time did his lesson end?
- (1) 5.40 p.m.
  - (2) 6.45 p.m.
  - (3) 7.00 p.m.
  - (4) 7.10 p.m.

**Section B**

Questions 21 to 40 carry 2 marks each. Show your working clearly in the space provided for each question and write your answers in the spaces provided. For questions which require units, give your answers in the units stated.

(40 marks)

Do not write  
in this space

*All diagrams in this paper are not drawn to scale unless stated otherwise.*

21.  $68\,904 = 60\,000 + 8000 + \underline{\hspace{2cm}} + 4$

What is the missing number?

Ans: \_\_\_\_\_

22. Write the missing number in the number pattern below.

12 000 , 11 600 , 11 200 , 10 800 , \_\_\_\_\_ , 10 000

Ans: \_\_\_\_\_

23. Express  $\frac{8}{24}$  in its simplest form.

Ans: \_\_\_\_\_

24. What is the value of  $\frac{5}{6} + \frac{2}{3}$ ?

Express your answer as a mixed number in the simplest form.

Ans: \_\_\_\_\_

Do not write  
in this space

25. Arrange the following fractions from the smallest to the greatest.

$$\frac{6}{7}, \frac{2}{7}, \frac{1}{2}$$

Ans: \_\_\_\_\_ , \_\_\_\_\_ , \_\_\_\_\_  
(smallest) (greatest)

26. ABCD is a square. Find  $\angle x$ .

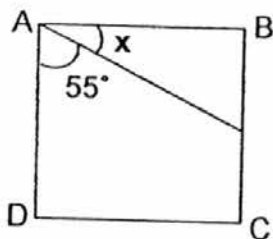

Ans: \_\_\_\_\_<sup>o</sup>

27. Write 6 thousandths as a decimal.

Do not write  
in this space

Ans: \_\_\_\_\_

28. Round off 16.59 to the nearest whole number.

Ans: \_\_\_\_\_

29. Write the decimal represented by A.

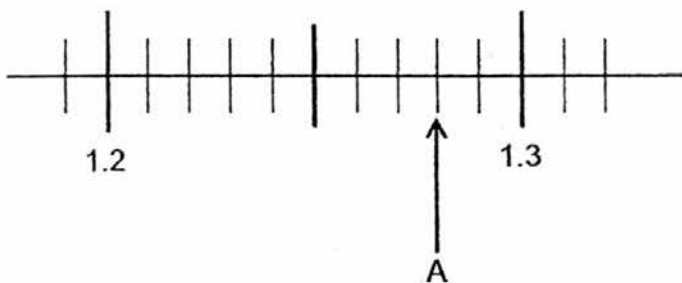

Ans: \_\_\_\_\_

30. I am a number greater than 12 but less than 40. I am a multiple of 6 and a factor of 48. What is my number?

Do not write in this space

Ans: \_\_\_\_\_

31. Judy had 5 m of ribbon at first. She used  $1\frac{1}{4}$  m of ribbon on Monday and  $1\frac{1}{3}$  m of ribbon on Tuesday. What was the length of ribbon she had left? Express your answer as a mixed number in the simplest form.

Ans: \_\_\_\_\_ m

32. The figure below is made up of squares. Shade **two** squares to form a symmetric figure with AB as the line of symmetry.

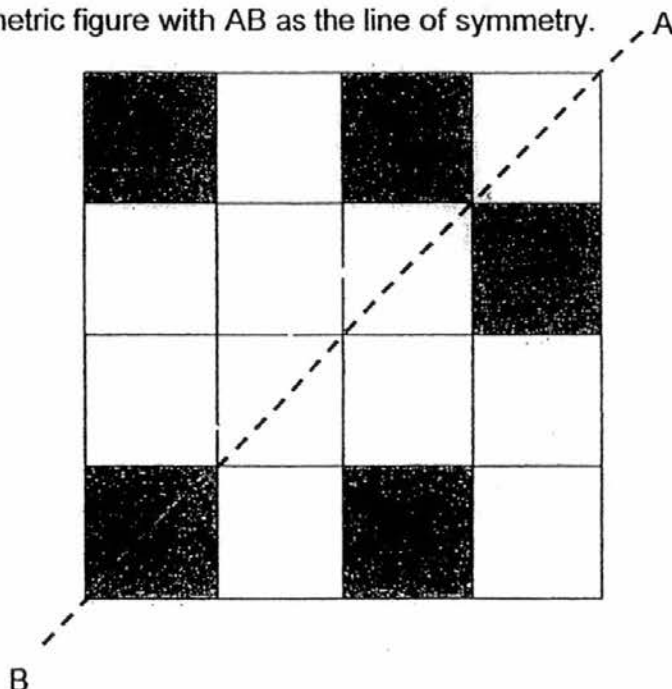

The bar graph below shows how Ravi spent all his pocket money. Study the graph carefully and answer questions 33 and 34.

Do not write in this space

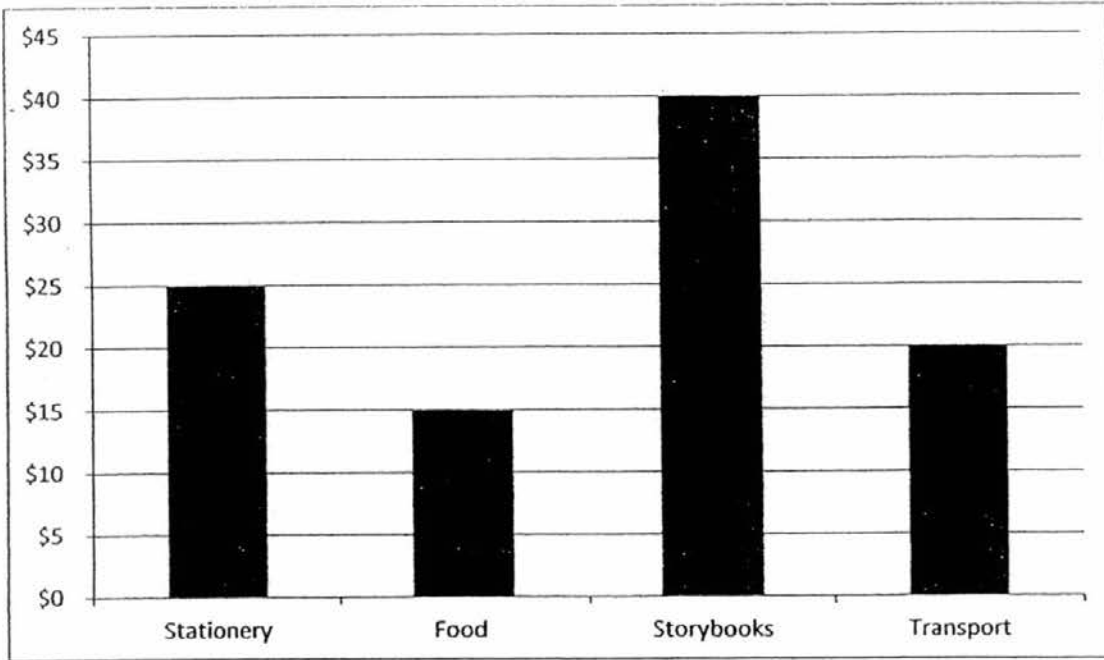

33. What was the total amount of Ravi's pocket money?

Ans: \$ \_\_\_\_\_

34. How much more did Ravi spend on buying storybooks than on stationery?

Ans: \$ \_\_\_\_\_

35. The figure shown below is made up of 4 similar rectangles. It has a perimeter of 48 cm. What is the area of one rectangle?

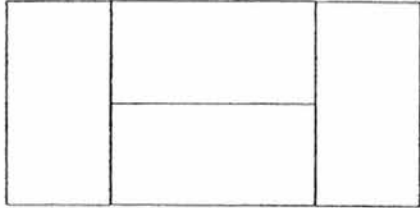

Do not write in this space

Ans: \_\_\_\_\_ cm<sup>2</sup>

36. Look at the figure below. The figure has 12 identical squares. What is the perimeter of the figure?

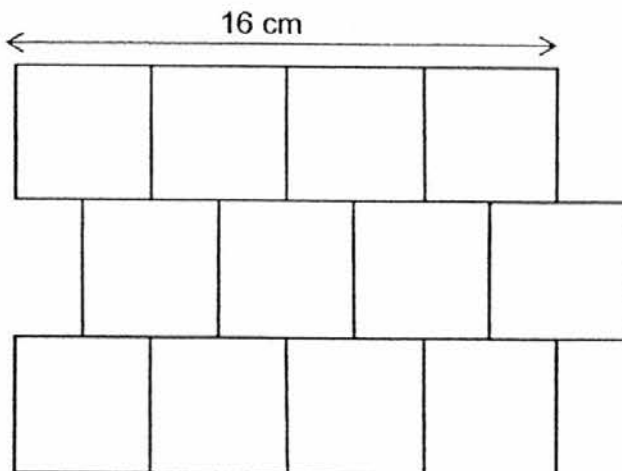

Ans: \_\_\_\_\_ cm



37. A movie ended at 01 20 on the next day. The duration of the movie was 1 h 55 min. Using the 24-hour clock, what time did the movie start?

Do not write  
in this space

Ans: \_\_\_\_\_

38. Kumar weighs 44.5 kg. His sister weighs 15.6 kg more than him. What is his sister's mass?

Ans: \_\_\_\_\_ kg

39. Rose saves \$44.50 in a week. Mark saves \$60 in a week. How much more will Mark save than Rose in 8 weeks?

Ans: \$ \_\_\_\_\_

40. Fatimah paid \$12.15 for 2 similar cans of drink and 3 similar cupcakes. If each cupcake costs \$3.25, how much does 1 can of drink cost?

Do not write  
in this space

Ans: \$ \_\_\_\_\_

**Section C**

For Questions 41 to 45, show your working clearly in the space provided for each question and write your answers in the spaces provided. The number of marks available is shown in brackets ( ) at the end of each question or part-question. For questions which require units, give your answers in the units stated.

Do not write  
in this space

***All diagrams in this paper are not drawn to scale unless stated otherwise.***  
(20 marks)

- 
41. Jolene had \$539 and Eva had \$275 at first. After each of them spent the same amount of money, Jolene had 4 times as much money as Eva. How much money did each of them spend?

.Ans: \_\_\_\_\_ [4]



42. There are 58 chickens and pigs on a farm. They have a total of 164 legs.  
How many chickens are there?

Do not write  
in this space

Ans: \_\_\_\_\_ [4]

43. Mr Sim sold some fruits.  $\frac{1}{6}$  of the fruits sold were durians.  $\frac{1}{4}$  of the fruits sold were papayas and the rest were watermelons. Mr Sim sold 28 more watermelons than papayas. How many fruits did he sell altogether?

Do not write  
in this space

Ans: \_\_\_\_\_ [4]

44. James used 3-cm square tiles to make figures as shown below.



Figure 1

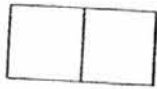

Figure 2

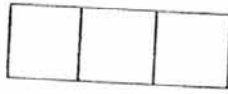

Figure 3

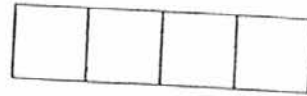

Figure 4

He recorded the area and perimeter of the first 3 figures in the table below.

Figure	Area of Figure	Perimeter of Figure
1	9 cm <sup>2</sup>	12 cm
2	18 cm <sup>2</sup>	18 cm
3	27 cm <sup>2</sup>	24 cm
4	36 cm <sup>2</sup>	?
.	.	
.	.	
.	.	
8	?	?

Do not write  
in this space

- What is the perimeter of Figure 4?
- What is the area of Figure 8?
- What is the perimeter of Figure 8?

Ans: a) \_\_\_\_\_ [1]

b) \_\_\_\_\_ [1]

c) \_\_\_\_\_ [2]

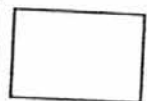

45. The diagram below shows the price of muffins

Do not write  
in this space

Muffins for sale	
First 6 muffins	\$2.50 each
Additional muffins	\$2 each



- a) What is the total cost of 6 muffins?  
b) If Mrs Raja has \$30, what is the greatest number of muffins she can buy?

Ans: a) \_\_\_\_\_ [1]

(b) \_\_\_\_\_ [3]

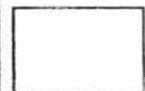

End of Paper

YEAR : 2016  
 LEVEL : PRIMARY 4  
 SCHOOL : ROSYTH  
 SUBJECT : MATHEMATICS  
 TERM : SA2

Section A

Q1	Q2	Q3	Q4	Q5	Q6	Q7	Q8	Q9	Q10
2	4	2	3	4	1	3	3	3	4
Q11	Q12	Q13	Q14	Q15	Q16	Q17	Q18	Q19	Q20
4	2	1	1	3	4	3	1	2	4

Section B

Q21 900

Q22 10 400

Q23  $\frac{1}{3}$

Q24  $1\frac{1}{2}$

Q25  $\frac{2}{7}, \frac{1}{2}, \frac{6}{7}$

Q26  $90^\circ - 55^\circ \Rightarrow \underline{35^\circ}$

Q27 0.006

Q28 17

Q29 1.28

Q30 Multiple of 6  $\rightarrow \overbrace{6, 12, 18, 24, 30, 36}^{24}$   
 Factors of 48  $\rightarrow \overbrace{1, 2, 3, 4, 6, 8, 12, 16, 24, 48}^{24} \Rightarrow \underline{24}$



Q31

$$\begin{aligned} \frac{1}{3} &\rightarrow \frac{4}{12} \\ \frac{1}{4} &\rightarrow \frac{3}{12} \\ \frac{4}{12} + \frac{3}{12} &= \frac{7}{12} \\ 5 - \frac{7}{12} &\Rightarrow 4\frac{5}{12} \text{ m} \end{aligned}$$

Q32

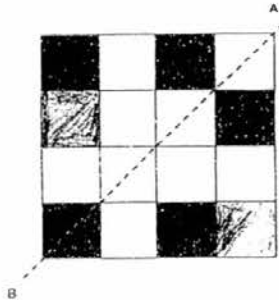

Q33

$$\$25 + \$15 + \$40 + \$20 \Rightarrow \underline{\$100}$$

Q34

$$\$40 - \$25 \Rightarrow \underline{\$15}$$

Q35

$$32 \text{ cm}^2$$

Q36

$$64 \text{ cm}$$

Q37

$$2325 \text{ hrs}$$

Q38

$$44.5 \text{ kg} + 15.6 \text{ kg} \Rightarrow \underline{60.1 \text{ kg}}$$

Q39

$$\begin{aligned} \$60 \times 8 &= \$480 \\ \$44.50 \times 8 &= \$356 \\ \$480 - \$356 &\Rightarrow \underline{\$124} \end{aligned}$$

Q40

$$\begin{aligned} \$3.25 \times 3 &= \$9.75 \\ \$12.15 - \$9.75 &= \$2.40 \\ \$2.40 \div 2 &\Rightarrow \underline{\$1.20} \end{aligned}$$

### Section C

- Q41      Diff  $\rightarrow \$539 - \$275 = \$264$   
             $3u \rightarrow \$264$   
             $1u \rightarrow \$264 \div 3 = \$88$   
            Spend  $\rightarrow \$275 - \$88 \Rightarrow \underline{\$187}$
- Q42      Total  $\rightarrow 4 \times 58 = 232$   
            Extra  $\rightarrow 232 - 164 = 68$   
            Difference  $\rightarrow 4 - 2 = 2$   
            Opposite  $\rightarrow 68 \div 2 \Rightarrow \underline{34 \text{ chickens}}$
- Q43       $\begin{array}{l} \{ 4u \rightarrow 28 \\ \times 3 \quad \{ \\ \{ 12u \rightarrow 28 \times 3 \Rightarrow \underline{84 \text{ fruits}} \end{array}$
- Q44      (a)       $4 + 4 + 1 + 1 \rightarrow 10u$   
                     $10 \times 3 \Rightarrow \underline{30 \text{ cm}}$
- (b)      Area of 1 sq  $\rightarrow 3 \times 3 = 9$   
                    Area of 8 sq  $\rightarrow 8 \times 9 \Rightarrow \underline{72 \text{ cm}^2}$
- (c)       $8 + 8 + 1 + 1 \rightarrow 18u$   
                     $18u \rightarrow 18 \times 3 \Rightarrow \underline{54 \text{ cm}}$
- Q45      (a)      1 muffin  $\rightarrow \$2.50$   
                    6 muffins  $\rightarrow \$2.50 \times 6 \Rightarrow \underline{\$15}$
- (b)      Left  $\rightarrow \$30 - \$15 = \$15$   
                    Add muffins  $\rightarrow 15 \div 2 = 7R1$   
                    No. of muffins  $\rightarrow 6 + 7 \Rightarrow \underline{13}$

End

www.testpaper.biz