

Methodist Girls' School (Primary)  
Semestral Assessment 1 2007  
Primary 5

Science

Thursday, 10 May

Booklet A

Name : \_\_\_\_\_ ( )

Class : P5\_\_\_\_\_

Total Time for Booklets A and B :

1h 45 min

---

DO NOT OPEN THIS BOOKLET UNTIL YOU ARE TOLD TO DO SO.

FOLLOW THE INSTRUCTIONS CAREFULLY.

ANSWER ALL QUESTIONS.

**SECTION A**

For questions 1 to 30, four options are given. One of them is the correct answer. Make your choice (1, 2, 3 or 4). Shade the correct oval (1, 2, 3 or 4) on the Optical Answer Sheet.

1. The flow diagram shows the route taken by food through the human body.

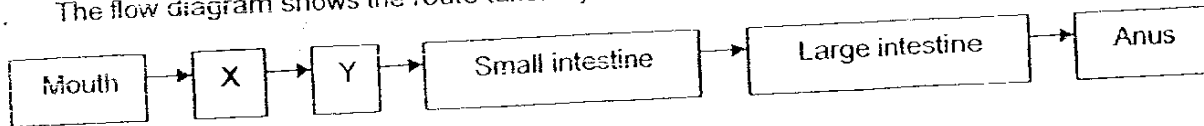

Which one of the following shows what X and Y represent?

	X	Y
(1)	Gullet	Lungs
(2)	Gullet	Stomach
(3)	Windpipe	Lungs
(4)	Windpipe	Stomach

2. The diagram on the right shows the human skeleton. Which of the joints indicated, allow movement in more than one direction?

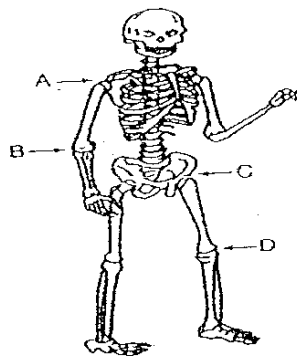

- (1) A and C only
- (2) B and D only
- (3) A, B and C only
- (4) B, C and D only

3. **A, B, C** and **D** represent the blood flowing in four different blood vessels of the **human** body. The arrows represent the direction of blood flow.

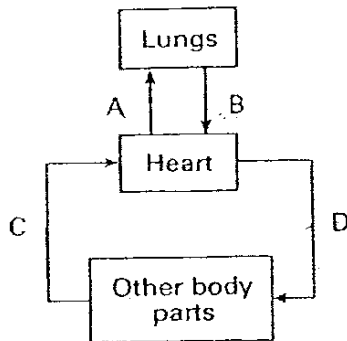

Which of the following statements is correct?

- (1) A is richer in oxygen than C.
  - (2) B is richer in oxygen than C.
  - (3) B is richer in carbon dioxide than D.
  - (4) D is richer in carbon dioxide than A.
4. Study the diagram below carefully.

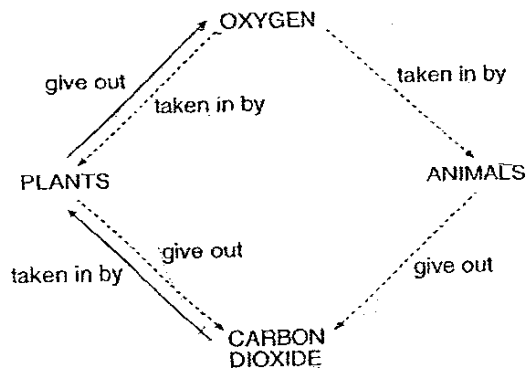

The arrows in continuous line (→) show a process that takes place \_\_\_\_\_.

- (1) all the time
- (2) only at night
- (3) during respiration
- (4) during photosynthesis

5. Susan placed a plant with two white flowers, X and Y, into a beaker containing blue-coloured water. She made two cuts as shown in the diagram below. After a short while, Flower X turned blue while the petals on Flower Y remained white.

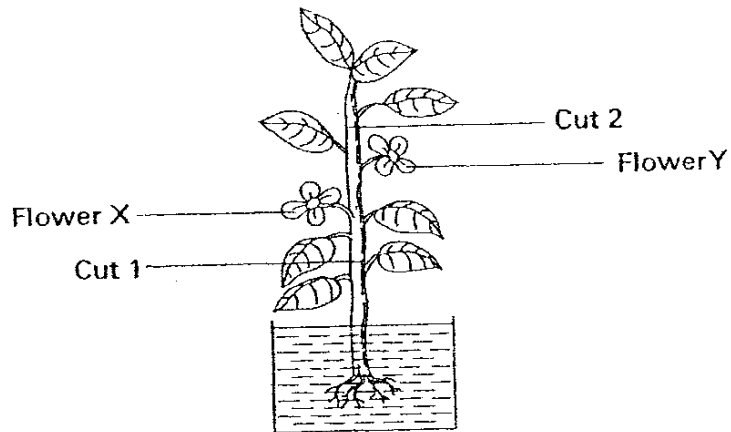

Which of the following diagrams show what Susan would observe when she looks at the cross-sections of the stem made at cuts 1 and 2 respectively?

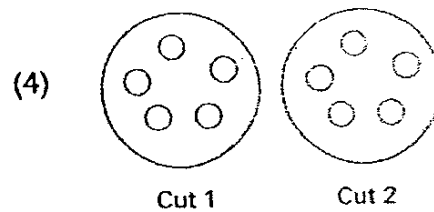
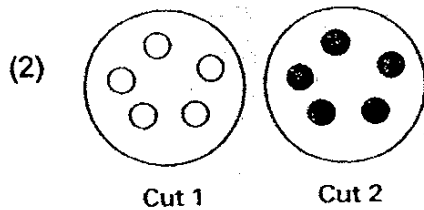
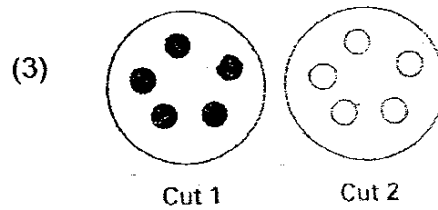
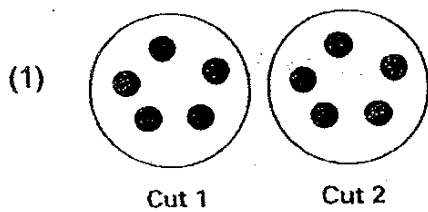

6. Which of the following is not found in a cell taken from an underground root?

- (1) Nucleus
- (2) Cytoplasm
- (3) Chloroplast
- (4) Cell membrane

7. The diagrams below show a cell undergoing cell division.

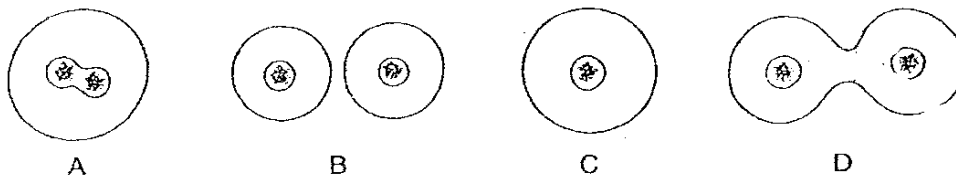

What is the correct order of the division?

- (1) A, C, B, D
- (2) C, A, D, B
- (3) B, C, D, A
- (4) B, D, A, C

8. Which is not a characteristic of genetic material found in the nucleus of cells?

- (1) Located in the brain only.
- (2) Stable, but also able to change.
- (3) Duplicated for each cell division.
- (4) Contains information to make an organism.

9. The diagram below shows the life cycle of animal X. The animal cannot be a \_\_\_\_\_.

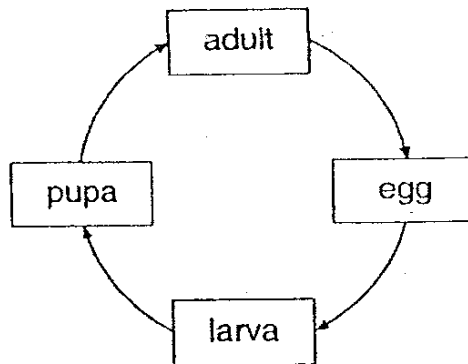

- (1) butterfly
- (2) mosquito
- (3) mealworm
- (4) grasshopper

10. To prevent the breeding of mosquitoes, places that tend to collect water, such as drains, are regularly sprayed with insecticide. Based on the life cycle of the mosquito, how can spraying insecticide in places that collect water help to stop mosquitoes from breeding?

- (1) The insecticide kills the female mosquitoes.
- (2) The insecticide does not allow the adult mosquitoes to breathe.
- (3) The insecticide stops the mosquito from completing its life cycle.
- (4) The insecticide increases the number of stages in the mosquito's life cycle.

11. A pollen grain has landed on a flower. In the diagram below, in which of the labelled parts will the male and female cells fuse?

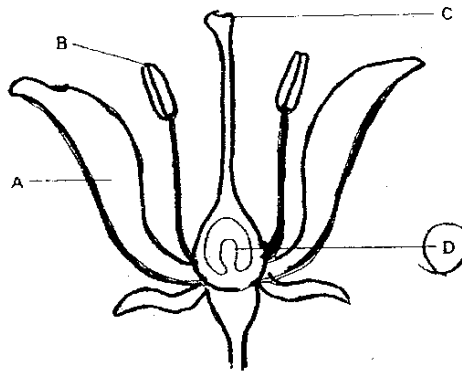

- (1) A
- (2) B
- (3) C
- (4) D

12. Geetha plucked a leaf from a bryophyllum plant as shown below.

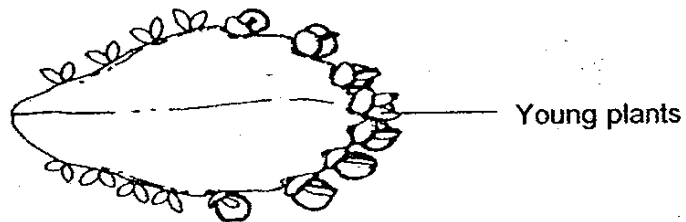

Based on the diagram of the leaf above, which of the following statements is **not** true?

- (1) The leaf can produce more than one plant at a time.
- (2) The leaf must be fertilised before it can produce young plants.
- (3) All the young plants on the leaf have the same characteristics.
- (4) The young plants have the same characteristics as the plant of the leaf.

13. What is/are the differences between external and internal fertilisation?

	Internal Fertilisation	External Fertilisation
A	Egg laying does not occur. <i>example: Birds!!!</i>	Egg laying occurs.
B	Eggs are fertilised and developed outside the mother's body. <i>ex: us</i>	Eggs are fertilised and developed inside the mother's body.
C	The sperm meets the ovum in the mother's body.	The sperm meets the ovum outside the mother's body.
D	All embryos are developed inside the mother's body. <i>example: Birds</i>	All embryos are developed outside the mother's body.

- (1) C only
- (2) A and B only
- (3) A and C only
- (4) C and D only

14. The table below shows the characteristics of 4 seeds or fruits, A, B, C and D.

Seed/Fruit	Size	Weight	Other Characteristics
A	Big	Heavy	Edible, has husk
B	Small	Light	Edible, it is a pod
C	Small	Light	Inedible, has stiff hair
D	Small	Light	Inedible, has fluffy hair

Which of the following shows the method by which A, B, C and D are probably dispersed?

	A	B	C	D
(1)	Animals	Water	Wind	Splitting
(2)	Water	Splitting	Animals	Wind
(3)	Animals	Wind	Splitting	Water
(4)	Water	Wind	Splitting	Animals



15. Tara took two angkana fruits, A and B, of the same size. She trimmed off the wing of fruit A, as shown in the diagram below.

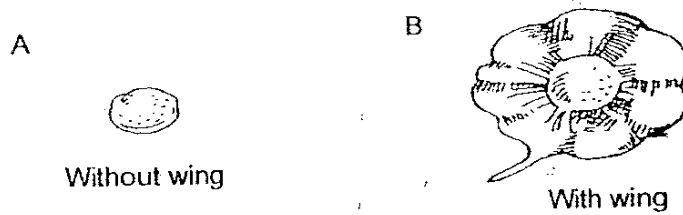

She dropped the fruits from the same height at the same place and recorded the time taken for each fruit to reach the ground. She repeated the experiment 3 times and calculated the average time for each fruit to reach the ground. Which set of readings is most likely to be correct?

	Average time of A	Average time of B
(1)	4.0 seconds	2.8 seconds
(2)	2.8 seconds	4.0 seconds
(3)	4.0 seconds	4.0 seconds
(4)	5.0 seconds	3.1 seconds

16. Which of the following is classified correctly?

	Metal	Non-metal
(1)	silver	brass
(2)	lead	gold
(3)	wood	copper
(4)	mercury	plastic

17. Betty compared the hardness of four rocks, A, B, C and D, by scratching them with different discs. She then recorded her observations in the table below.

Rock	Presence of scratch marks made by:		
	plastic disc	iron disc	wooden disc
A			
B		✓	✓
C	✓	✓	✓
D			✓

Which of the following correctly shows the four rocks arranged in increasing order of their hardness?

soft → hard

- (1) A B D C  
 (2) B C D A  
 (3) C B D A  
 (4) D B A C

18. The table below shows the freezing and boiling points of three unknown substances X, Y and Z.

Substance	Freezing point (°C)	Boiling point (°C)
X	27	85
Y	30	115
Z	63	184

Which of the substances X, Y and Z exist/s in the liquid state at 100°C?

- (1) X only  
 (2) Y only  
 (3) X and Y only  
 (4) Y and Z only

19. Melissa dissolved 20 g of salt in a beaker containing 200 g of water. After 3 days, she found that only 120 g of the solution was left in the beaker. The remaining solution would contain about \_\_\_\_\_.

- (1) 20 g of salt only
- (2) 120 g of water only
- (3) 100 g of water and 20 g of salt
- (4) 120 g of water and 20 g of salt

20. Small holes were pierced in the two cans of condensed milk, A and B, as shown below.

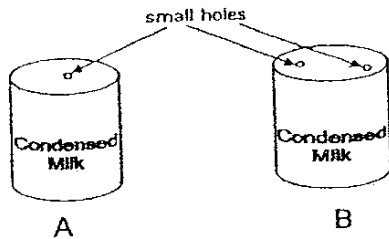

Milk would flow out more easily from can \_\_\_\_\_.

- (1) A because air pushes the milk out
- (2) A because milk can flow out of the hole
- (3) B because air is able to enter through both holes and milk can flow out through both holes
- (4) B because air is able to enter through one hole and milk can flow out from the other hole

21. Sam filled beaker X with some pebbles and beaker Y with 30 ml of water as shown in the diagram below.

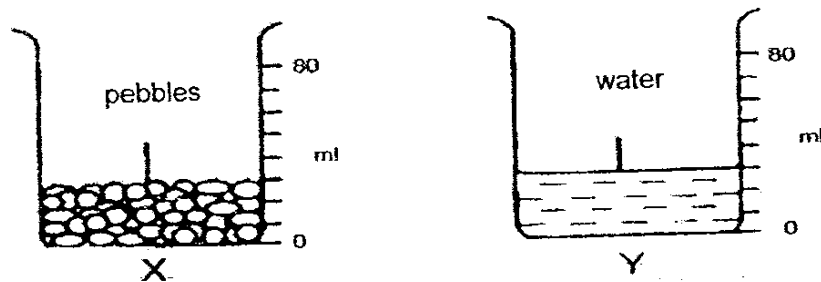

Next, he poured the water from beaker Y into beaker X without spilling. The volume occupied by the water and the pebbles in beaker X is likely to be \_\_\_\_\_.

- (1) 30 ml
  - (2) 55 ml
  - (3) 60 ml
  - (4) 75 ml
22. Ali filled 4 beakers, A, B, C and D with equal amount of water and placed them side by side on the table. Water droplets will probably formed on the outer surface of beaker \_\_\_\_\_.

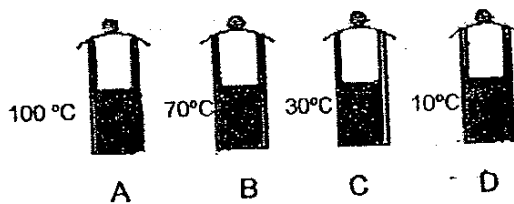

- (1) A only
- (2) D only
- (3) B and C only
- (4) A, C and D only

23. The diagram below shows a pump connected to a glass jar. The capacity of the jar is  $500 \text{ cm}^3$ . The jar contains  $50 \text{ cm}^3$  of water.

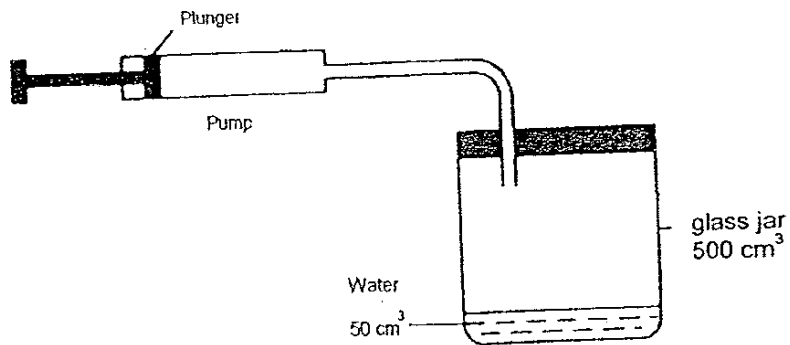

When the plunger is pushed in completely,  $30 \text{ cm}^3$  of air is forced into the jar. What is the volume of air in the jar?

- (1)  $30 \text{ cm}^3$
- (2)  $450 \text{ cm}^3$
- (3)  $480 \text{ cm}^3$
- (4)  $550 \text{ cm}^3$

24. The diagram below represents the water cycle.

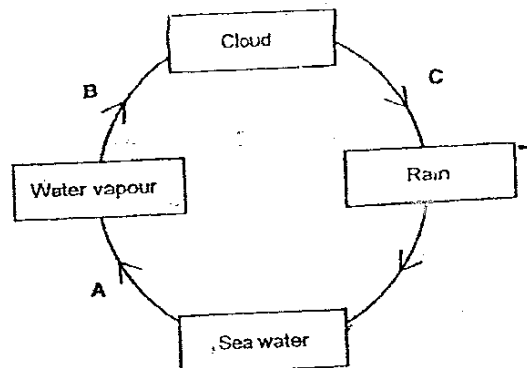

Which one of the following is correct?

	Evaporation occurred at	Condensation occurred at
(1)	A	B
(2)	B	C
(3)	C	B
(4)	C	A

25. Bala sees a full moon on 18 February. He would most likely see a \_\_\_\_\_ on 4 March.

- (1) half moon
- (2) new moon
- (3) gibbous moon
- (4) crescent moon

26. Study the chart shown below carefully.

	Mercury	Venus	Earth	Mars	Jupiter	Saturn	Uranus	Neptune
Distance from the Sun (millions of km)	60	108	150	228	778	1430	2870	4500
Diameter of planet (km)	4900	12 100	13 000	68 00	134 000	75 000	51 000	49 000
Surface Temperature (°C)	430	500	-30 to 50	-140 to 20	-150	-180	-220	-230

Suppose two new planets X and Y have been discovered. Planet X is located between Venus and Earth and is about the same size as Venus. Planet Y is located between Uranus and Neptune and is about the same size as Uranus. Which one of the following conclusions based on the above information is **true**?

- (1) Planet X will be colder than Planet Y.
- (2) Planet X will be hotter than Planet Y.
- (3) Planet Y will be heavier than Planet X.
- (4) Planet Y will be smaller than Planet X.

27. Study the diagram shown below carefully.

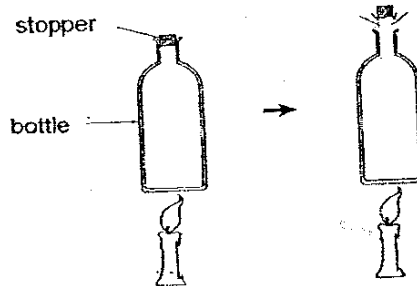

The \_\_\_\_\_ and caused the stopper to pop out.

- (1) bottle expands upon heating
- (2) bottle contracts upon heating
- (3) air in the bottle expand upon heating
- (4) air in the bottle contracts upon heating

28. Samy heated 250 ml of pure water in a beaker. He recorded the volume of the water in the beaker and its temperature at 5 minute intervals. The table below shows the results of her experiment.

Time (min)	Volume of water (ml)	Temperature (°C)
0	250	26
5	230	40
10	210	70
15	190	100
20	?	?

What could be the volume and temperature of the water at the 20<sup>th</sup> minute?

	Volume (ml)	Temperature (°C)
(1)	190	100
(2)	190	130
(3)	170	100
(4)	170	130

29. A shadow is formed because \_\_\_\_\_.

- A: Light can be reflected.
- B: Light only travels in a straight line.
- C: Light passes through some objects.
- D: Light is blocked by an opaque object.

- (1) A and B only
- (2) B and D only
- (3) C and D only
- (4) A, B and D only



30. Two identical cones were placed in different positions directly under the same light sources in a dark room as shown below.

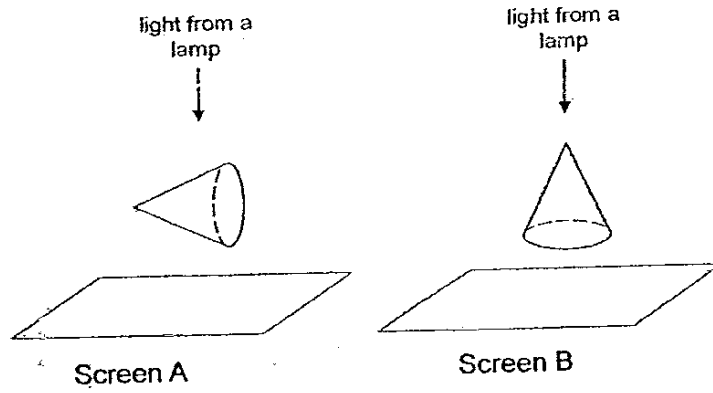

Which of the following correctly shows the shadows that would be observed on each screen?

	Screen A	Screen B
(1)		
(2)		
(3)		
(4)		

Methodist Girls' School (Primary)  
Semestral Assessment 1 2007  
Primary 5

Science

Thursday, 10 May

Booklet B

Name : \_\_\_\_\_ ( )

Class : P5\_\_\_\_\_

Total Time for Booklets A and B : .

1h 45 min

Booklet A (60marks)	
Booklet B (40marks)	
<b>Total (100 marks)</b>	

---

DO NOT OPEN THIS BOOKLET UNTIL YOU ARE TOLD TO DO SO.

FOLLOW THE INSTRUCTIONS CAREFULLY.

ANSWER ALL QUESTIONS.

For questions 31 to 46, write your answers in the blanks provided.

31. Two species of plants, A and B, can be found in an area represented in the map below.

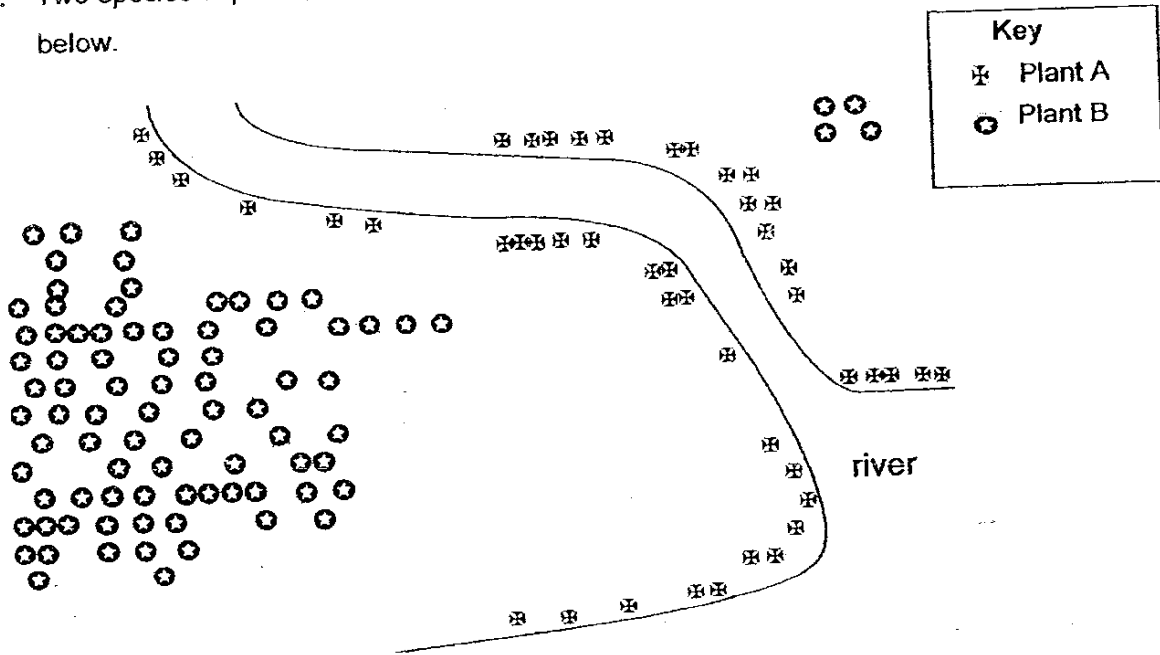

(a) State the method of dispersal of Plants A and B (1m)

Plant A \_\_\_\_\_

Plant B \_\_\_\_\_

(b) Name one characteristic of plant A which enables it to be dispersed by the method mentioned above. (1m)

\_\_\_\_\_

32. Linda performs an experiment on germination.

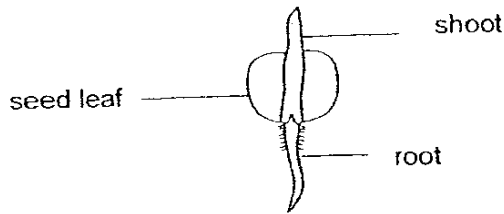

(a) In germination the part that grows first is the \_\_\_\_\_ followed by the \_\_\_\_\_. (1m)

(b) Linda plotted a graph showing the changes in mass of the seed leaf and the shoot of the seedling during an experiment. The experiment is conducted at room temperature.

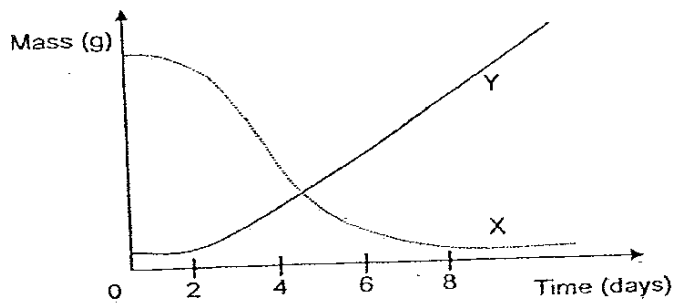

(i) Which curve X or Y, shows how the mass of the seed leaf changes during the experiment? Give a reason for your answer. (1m)

(ii) What would happen to the seed if there were no sunlight throughout the first eight days? (1m)

(iii) How did the seedling get its food from day 8 onwards? (1m)

33. The diagram below shows a system of the human body.

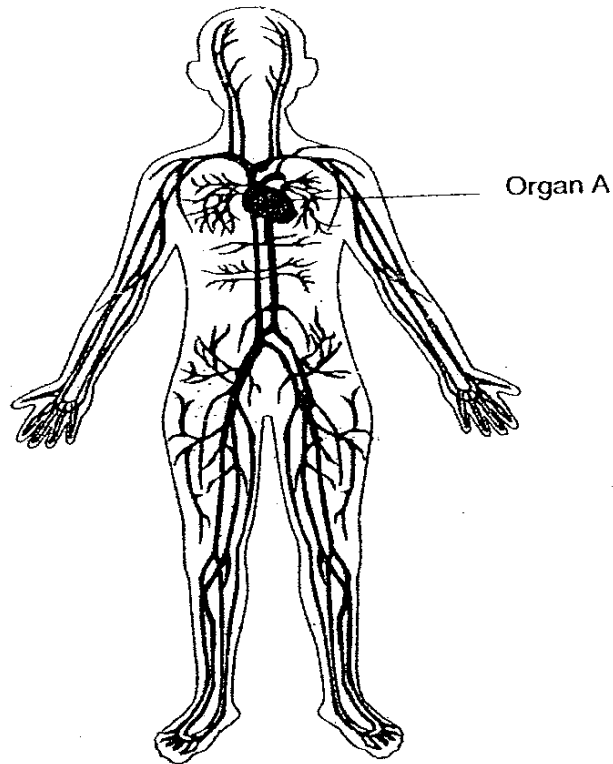

Fill in the blanks with the correct answer.

The function of organ A is to pump \_\_\_\_\_ around the body and when a person runs, it heats \_\_\_\_\_ so that the cells can produce more \_\_\_\_\_. The part of the skeletal system that protects organ A is the \_\_\_\_\_. (2m)

34. The following diagram shows the family tree of Jason.

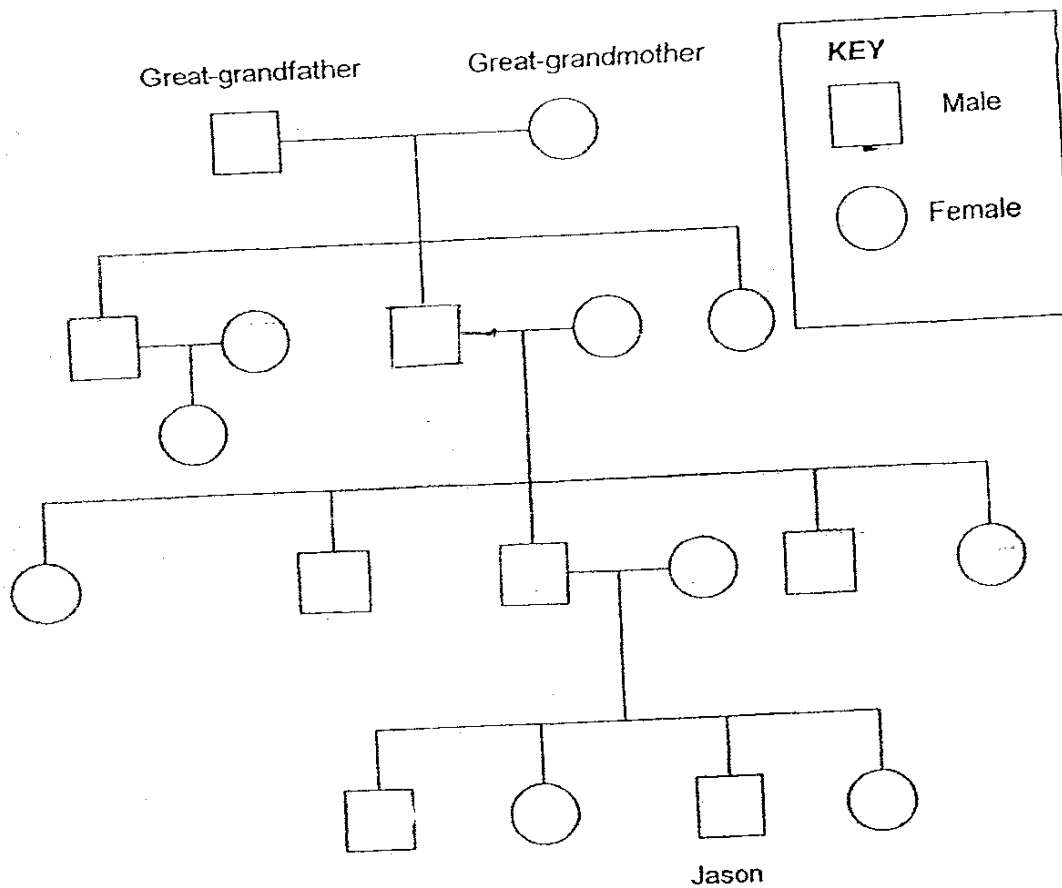

(a) How many children do Jason's great-grandparents have? (1m)

---

(b) How many aunts does Jason have? (1m)

---

(c) Shade the symbol which represents Jason's grandfather. (1m)

35. Study the diagram below.

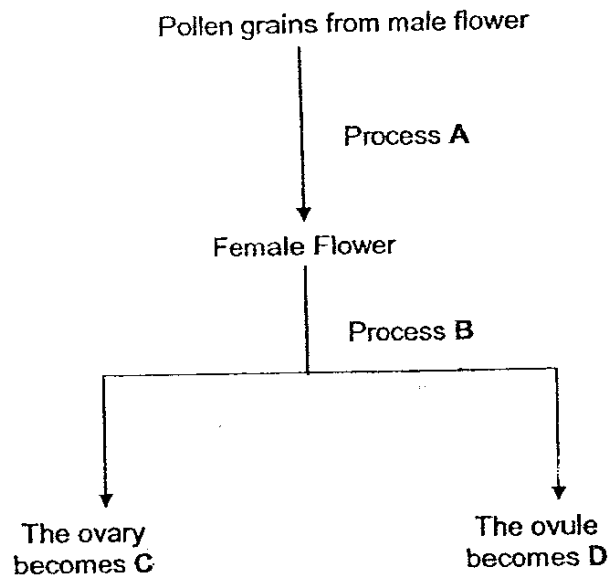

Identify A, B, C and D. (2 m)

A: \_\_\_\_\_

B: \_\_\_\_\_

C: \_\_\_\_\_

D: \_\_\_\_\_

36. The following diagram shows a yeast cell reproducing itself.

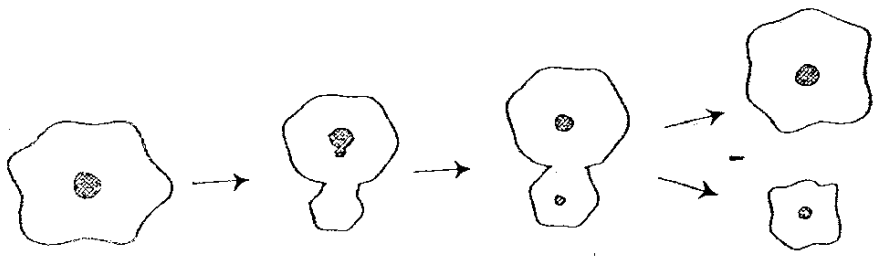

(a) What is the name of this method of reproduction? (1m)

(b) In the box below, **sketch** a simple diagram to show the number of cells that would be formed at the 3<sup>rd</sup> generation of cell division from a single parent cell. (1m)

Generation 1



37. The diagram shows the life cycle of a frog.

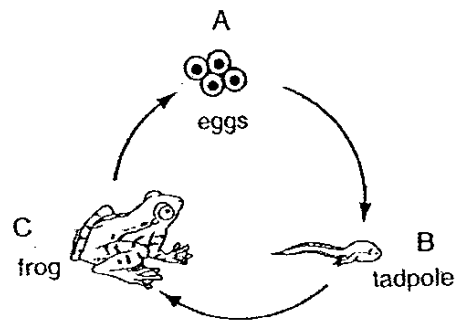

(a) At which stage can the frog reproduce? (1m)

---

(b) Why does a frog need to produce so many eggs for reproduction? (1m)

---

---

38. The diagram below shows part of the skeletal system of the human arm.

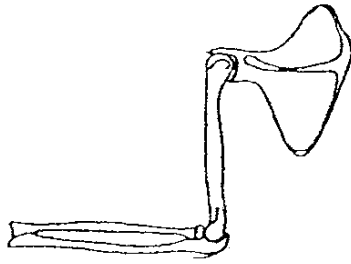

(a) What other feature, not shown on the diagram, helps in the movement of the arm? (1m)

---

(b) On the diagram, circle the part which allows you to bend or straighten your arm at the elbow. (1m)

(c) Name another part of the body where you can find a similar joint. (1m)

---

39. Study the diagram shown below carefully:

(a) **Shade** on the diagram shown below the part of the Earth that would experience night. (1m)

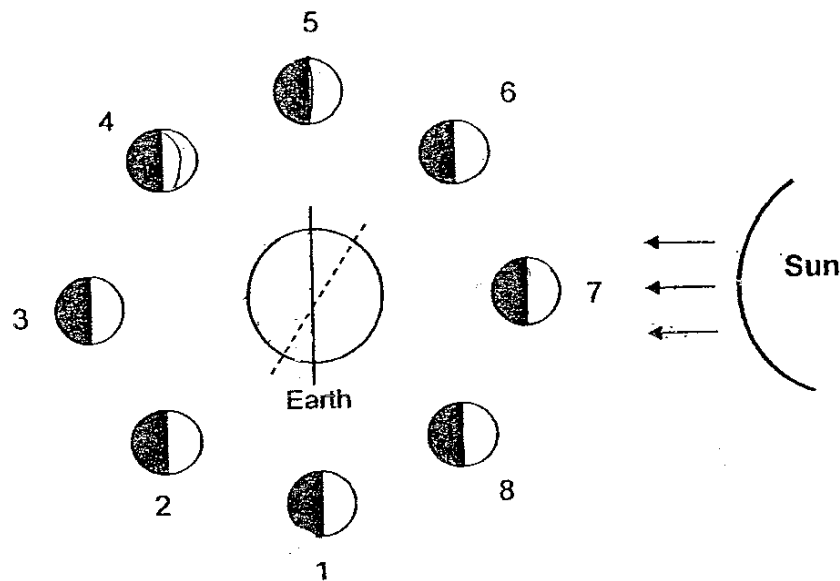

(b) At which position(s) can you see the crescent moon? (1m)

---

(c) What causes the apparent movement of the Sun across the sky? (1m)

---



---

40(a) In what way is the Moon different from the Earth as a satellite? (1m)

---

(b) State a similarity between the Moon and a communication satellite. (1m)

---

41. In an experiment, some wax was placed on the top end of three rods, A, B and C. The rods were then placed on top of a hot surface as shown below.

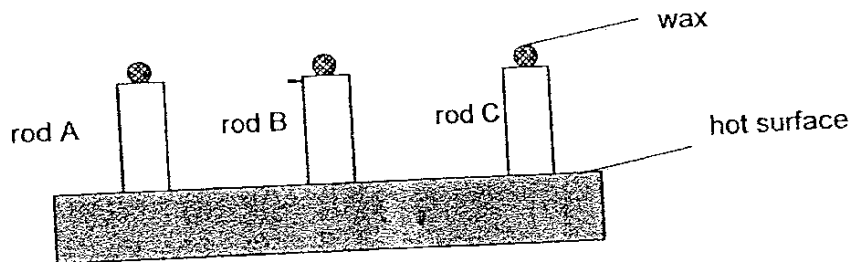

It was observed that the wax on rod B melted first, followed by that on rod A and then rod C.

- (a) What can be concluded about the conduction of heat in rods A, B and C? (1m)

---



---

- (b) If the three rods above were made of wood, copper, and porcelain, identify the materials that Rods A, B and C were made of. (3m)

Wood	
Copper	
Porcelain	

27

42. The diagram below shows the three states of a substance.  
Write in the boxes the words "given out" or "taken in" to indicate whether heat is taken in or given off by the substance during each change of state. (2m)

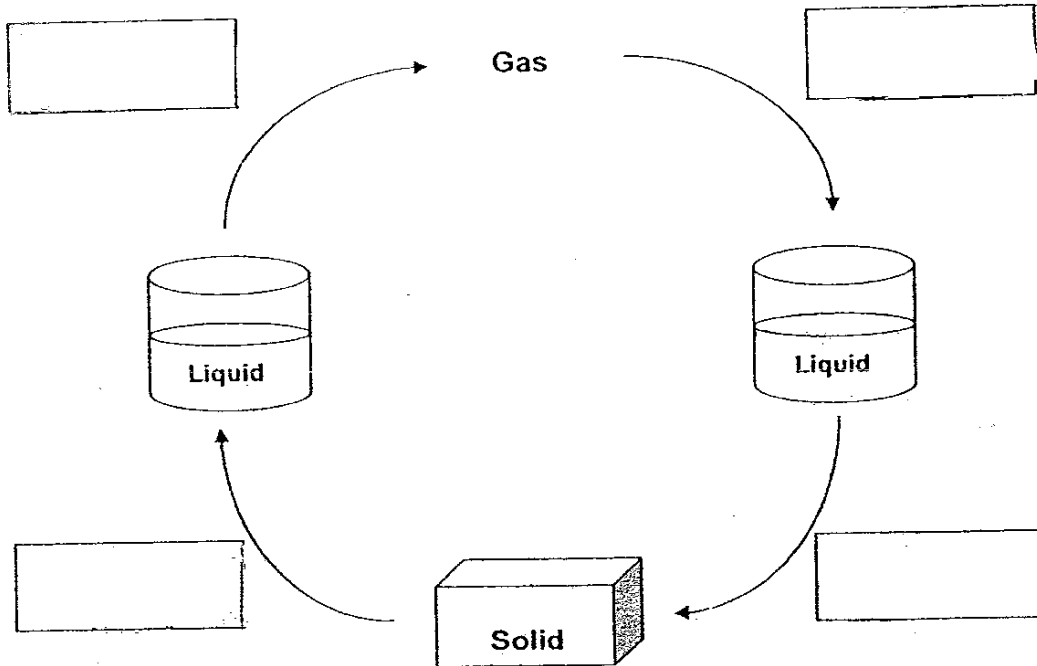

43. Mrs Lim conducted an experiment for her class. She put a temperature probe into a glass beaker containing very hot water to measure the temperature of the water as it cooled.

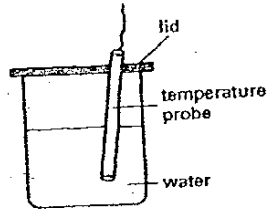

The computer took the temperature of the water every 15 seconds and drew a graph shown below.

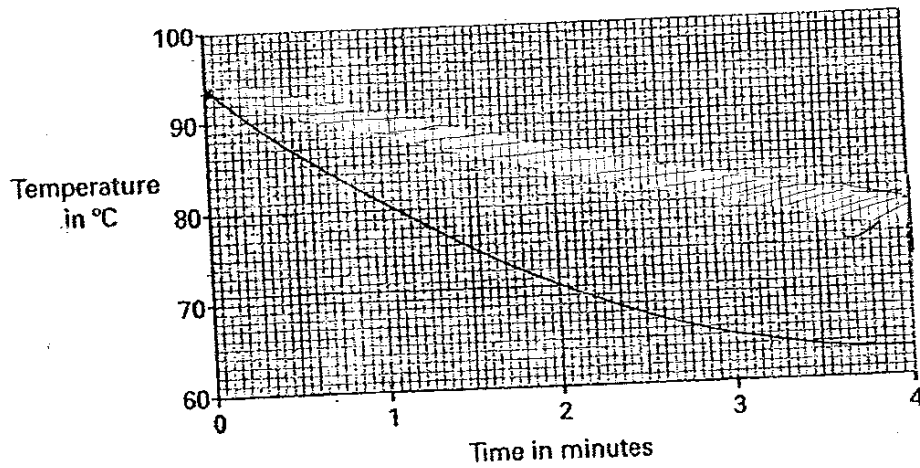

- (a) What was the temperature of the water at the 2<sup>nd</sup> minute? (1m)

Mrs Lim wrapped a towel around the beaker and conducted the experiment again.

- (b) On the graph above, sketch the graph you would expect the computer to show. (1m)

44. Tom placed his torchlight at an angle  $X^\circ$  to shine at a stick as shown in the diagram below. Then he measured the length of the shadow.

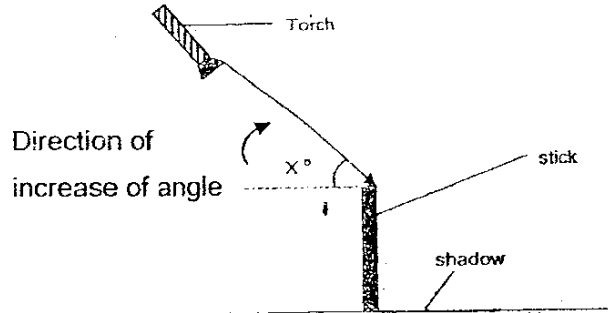

He repeated the experiment, increasing the angle of the light source each time in the direction shown. Then he recorded his observation as follows:

Angle of light source (degrees)	Length of shadow (cm)
50	25
60	20
70	15
80	10
90	0
100	10
110	?
120	20

- (a) Based on the results, what should the length of the shadow be when the angle of the light source is at  $110^\circ$ ? (1m)

---

- (b) From the results, what can he conclude about the relationship between the angle of the light source and the length of the shadow formed? (2m)

---



---

45. Rani had 4 magnets, A, B, C and D, as shown below.

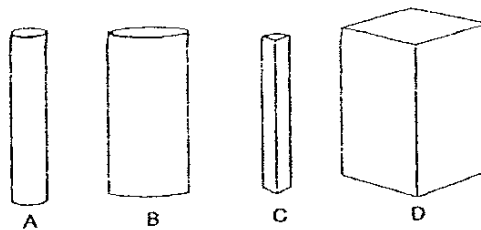

To compare the strength of the magnets, she placed each of the magnets near a pile of pins. The table below shows the number of pins attracted by the magnets from various distances.

Magnet	Distance between magnet and pins (cm)	Number of pins attracted
A	6	14
B	4	14
C	7	12
D	4	16

Based on the results above, put a tick (✓) in the correct box to indicate whether each of the statements is **True**, **False** or **Not Possible to Tell**. (2m)

Statement	True	False	Not Possible to Tell
(a) Magnet B is as strong as Magnet A.			
(b) Magnet D is stronger than Magnet B.			
(c) Magnet C is the weakest of all the magnets.			
(d) Magnet B is stronger than Magnet C.			



46. Study the flow chart shown below carefully.

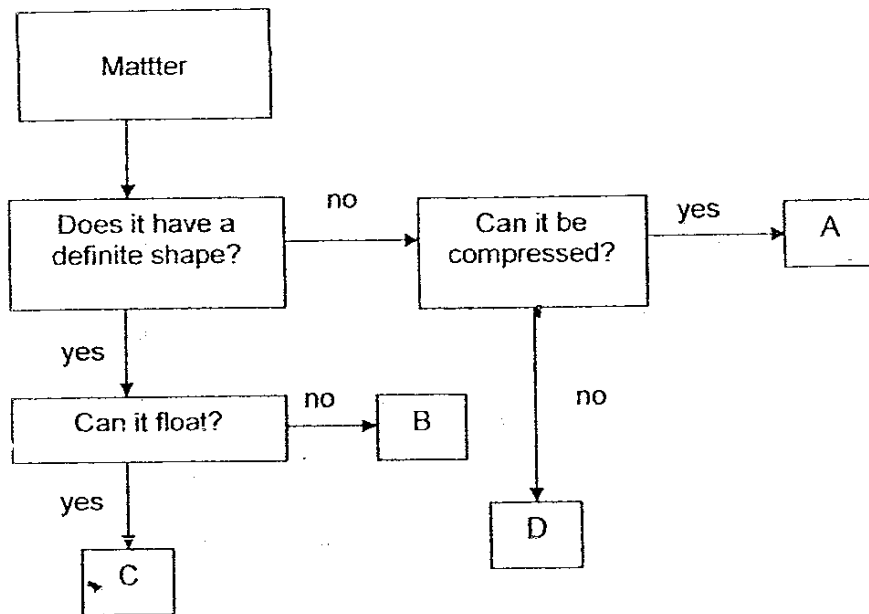

(a) Where would you place 'plastic plate' in the classification chart shown above? (1m)

---

(b) What is the state of D? (1m)

---

-----END OF PAPER-----

MGS Primary School  
Primary 5 Science SA1 Exams (2007)

**Answer Keys**

**SECTION A : (60 MARKS)**

Qn no.	Ans
1	2
2	1
3	2
4	4
5	3
6	3
7	2
8	1
9	4
10	3

Qn no.	Ans
11	4
12	2
13	1
14	2
15	2
16	4
17	3
18	4
19	3
20	4

Qn no.	Ans
21	2
22	2
23	2
24	1
25	2
26	2
27	3
28	3
29	1
30	3

**SECTION B (40 MARKS)**

31a. A : by water  
 B : explosive force

31b. Fibrous husk

32a. Root, shoot

32b.(i) X. Food in the seed leaf is used for the growth of the shoot and root.

(ii) The seed will still grow.

(iii) From its green leaves and through photosynthesis

33. Blood ,faster , energy , ribcage

34a. Three

34b. Two aunts

34c.

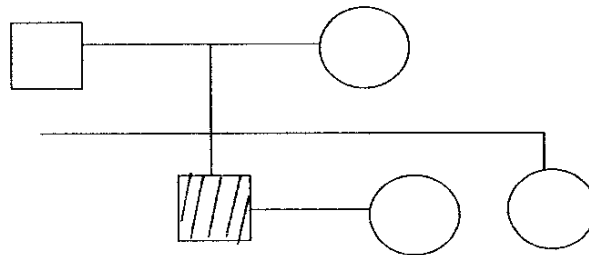

35a. Pollination

35b. Fertilization

35c. Fruit

35d. Seed

- 36a. **Budding**  
 36b.

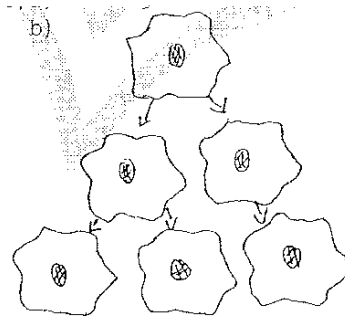

- 37a. **Stage C.**  
 37b. **Not all tadpoles make it to adulthood, some would be eaten by predators**

- 38a. **The muscles**  
 38b.

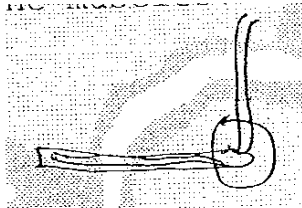

- 38c. **The kneecaps**

- 39a.

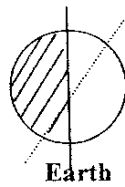

- 39b. **Positions 6 and 8**  
 39c. **The cause of it is the earth spinning on its own axis**

- 40a. **The earth revolves around the sun, while the moon revolves around the earth.**  
 40b. **Both revolve around the earth.**

- 41a. **Rod B is the best conductor of heat, followed by A then C**  
 41b. **C,B,A**

42.

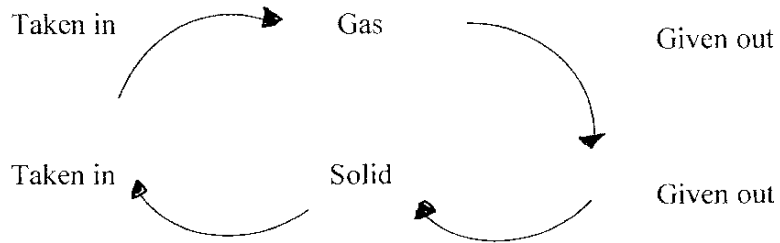

43a. 71°C

43b.

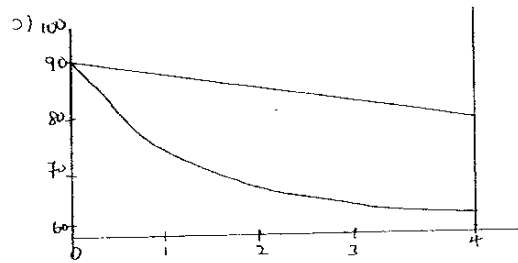

44a. 15cm

44b. The length of the decreases as the angle of light source increase until 90° C, there after the length of shadow increases as the angle of light source increases

45a. False

45b. True

45c. Not

45d. Not

46a. C

46b. Liquid state