



Rosyth School
Second Semestral Examination for 2016
STANDARD SCIENCE
Primary 5

Name: _____

Class: Pr 5 - _____ Register No. _____ Duration: 1 h 45 min

Date: 1st Nov 2016 Parent's Signature: _____

Booklet A

Instructions to Pupils:

1. Do not open the booklets until you are told to do so.
2. Follow all instructions carefully.
3. This paper consists of 2 booklets, Booklet A and Booklet B.
4. For questions 1 to 28 in Booklet A, shade the correct ovals on the Optical Answer Sheet (OAS) provided using a 2B pencil.

* This booklet consists of 19 printed pages (including cover page).

Part I

For each question from 1 to 28, four options are given. One of them is the correct answer. Make your choice and shade the correct oval (1, 2, 3 or 4) on the Optical Answer Sheet. (56 marks)

1. Study the diagram below.

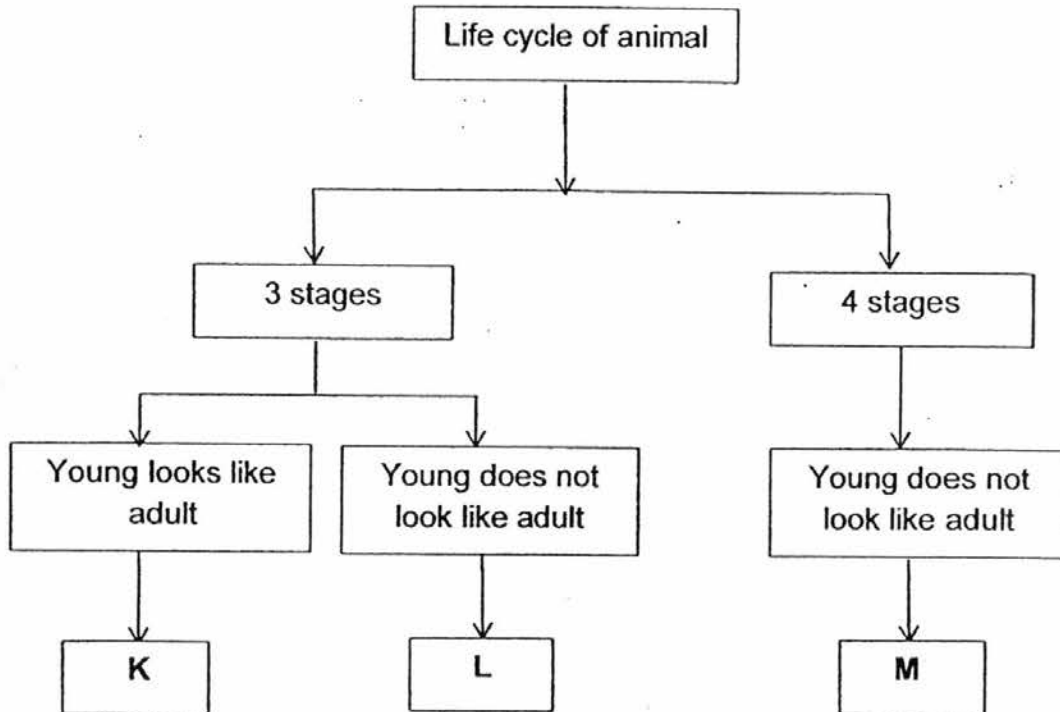

Which one of the following represents K, L and M?

	K	L	M
(1)	frog	butterfly	grasshopper
(2)	grasshopper	frog	butterfly
(3)	butterfly	grasshopper	frog
(4)	grasshopper	butterfly	frog

2. The diagram below shows the development of a bed bug from an egg to an adult.

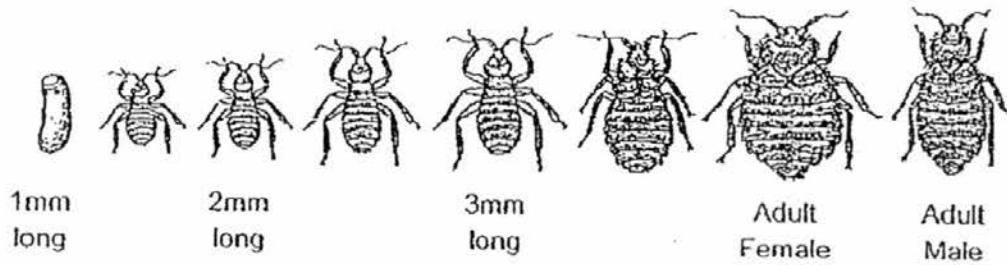

Based on the development shown above, how many stages is the lifecycle of the bed bug?

- (1) seven-stage lifecycle (2) two-stage lifecycle
(3) three-stage lifecycle (4) four-stage lifecycle
3. Why is the cell wall in a plant cell important?
- A: It protects the cell from damage.
B: It helps to keep the cell its cell shape.
C: It controls the movement of substances in and out of the cell.
- (1) C only (2) A and B only
(3) B and C only (4) A, B and C

6. Jerome cut an outer ring of the stem between positions K and L of a plant as shown below. The food-carrying tubes between positions K and L were removed while the water-carrying tubes remained in the stem.

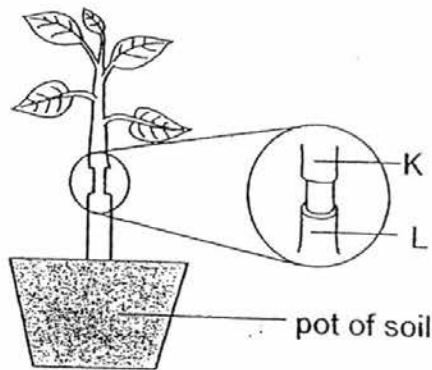

After some time, he observed that one part of the stem was swollen.
Which part of the stem, K or L, was swollen and what would be the reason?

	Swollen part	Reason
(1)	K	Water absorbed by the roots had travelled upwards and stored at K.
(2)	K	Food made by the leaves was unable to travel downwards and stored at K.
(3)	L	Water absorbed by the roots was unable to travel upwards and stored at L.
(4)	L	Food made by the leaves had travelled downwards and stored at L.

7. The diagram below shows how water and food are transported in a plant.

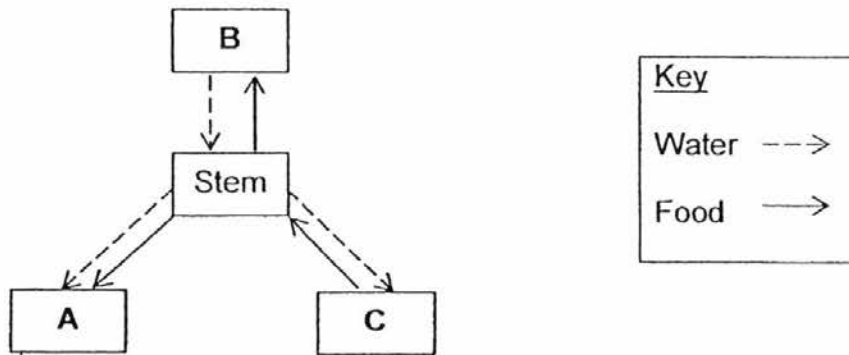

Which one of the following shows the parts of the plants correctly?

	A	B	C
(1)	leaves	roots	flowers
(2)	roots	flowers	leaves
(3)	flowers	leaves	roots
(4)	flowers	roots	leaves

8. The diagram below represents how blood flows in certain parts of the body.

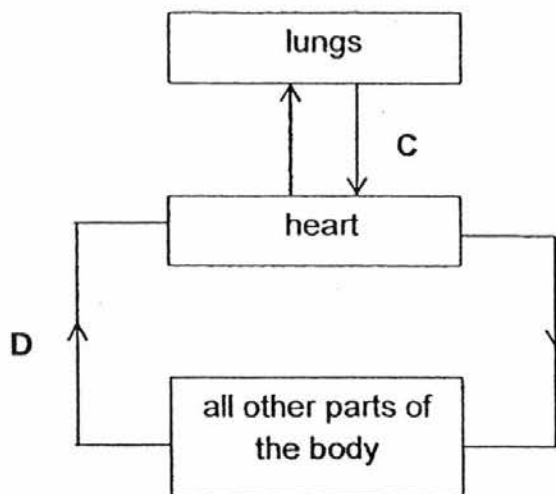

Which one of the following is true?

	Blood in C	Blood in D
(1)	rich in carbon dioxide	rich in oxygen
(2)	rich in carbon dioxide	poor in oxygen
(3)	poor in carbon dioxide	poor in oxygen
(4)	poor in carbon dioxide	rich in oxygen

9. Which one of the following graphs shows the relationship between heart rate and breathing rate of a man who is exercising?

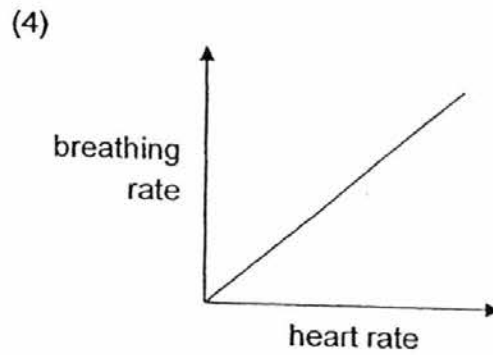
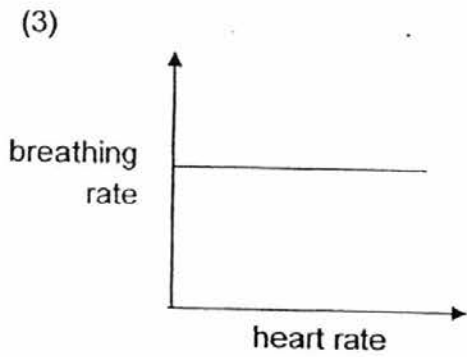
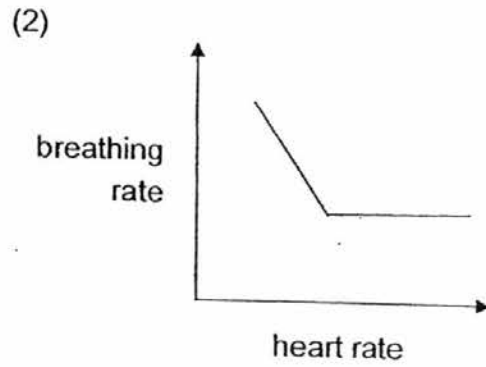
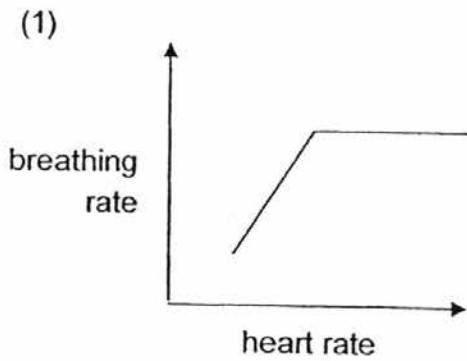

10. Exhaled air has _____ than inhaled air.

- (1) more heat
- (2) more oxygen
- (3) less nitrogen
- (4) less carbon dioxide

11. The diagram below shows the female reproductive system.

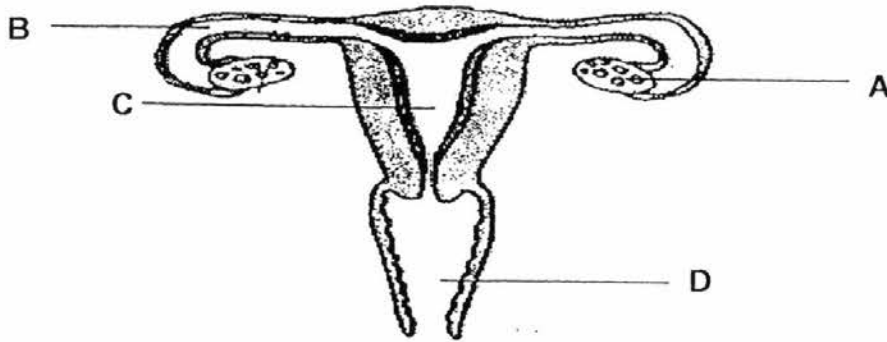

Where does the development of a fertilised egg take place?

- (1) A
(2) B
(3) C
(4) D
12. The diagram below shows different parts of a flower.

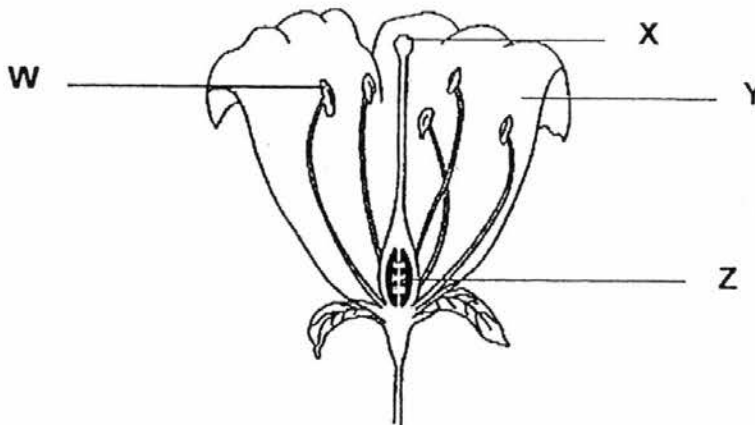

Which parts of the flower, when removed, would still allow fertilisation to take place?

- (1) W and X only
(2) W and Y only
(3) X and Z only
(4) Y and Z only

13. Fruits A and B are from different plants.

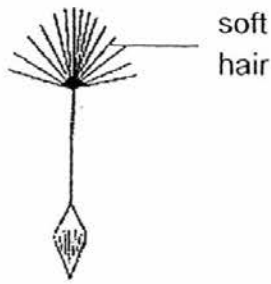

Fruit A

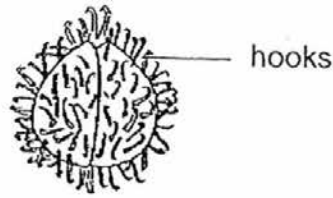

Fruit B

How are fruits A and B most likely dispersed?

	Fruit A	Fruit B
(1)	wind	animal
(2)	wind	water
(3)	water	animal
(4)	animal	water explosive action

14. Jamie conducted an experiment and concluded that light is not needed for seed germination. She recorded her results in the table below.

Set-up	Conditions				Observation
	light	warmth	air	water	
A	absent	present	present	present	seeds germinated
B	present	present	present	present	seeds germinated
C	present	absent	absent	absent	seeds did not germinate
D	absent	absent	present	present	seeds did not germinate

Which of the following set-ups will support Jamie's conclusion?

- (1) A (2) B
(3) C (4) D

15. James conducted an experiment by placing four similar measuring cylinders, A, B, C and D, as shown below under sunlight for eight hours.

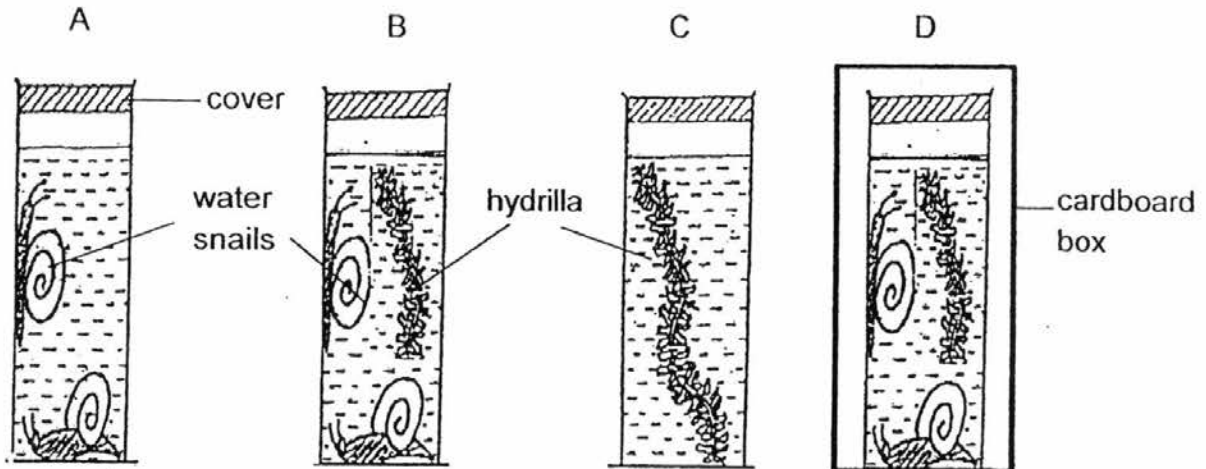

Arrange the cylinders starting from the least amount of carbon dioxide to the most amount of carbon dioxide at the end of the experiment.

- (1) A, B, C, D
 (2) B, C, A, D
 (3) C, B, A, D
 (4) D, A, B, C
16. Travis wanted to conduct an experiment on a leaf of a potted plant. The potted plant was left in a dark cupboard for a few days before the experiment.

Cardboard-A had a hole in the middle, cardboard B had no hole, cardboard C had black paper in the middle and cardboard D had clear plastic in the middle.

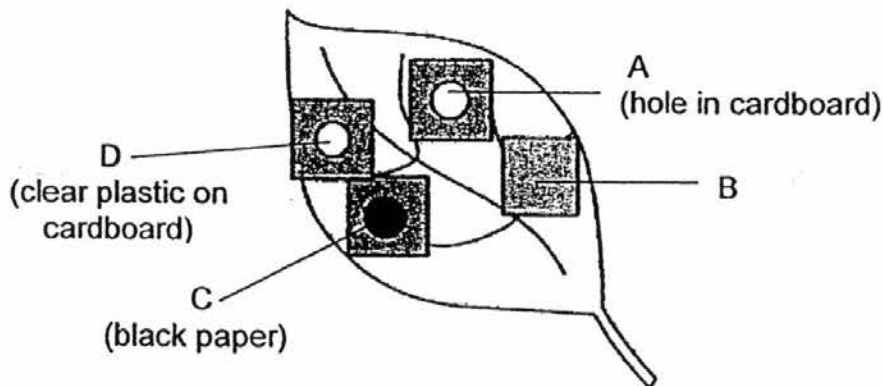

The plant was then placed under the sun for a few hours. The leaf was then plucked off and tested for starch. Which part(s) of the leaf would starch be present?

- (1) B only
 (2) B and C only
 (3) A, C and D only
 (4) A and D only

17. Mrs Ong wanted to find out if adding fertiliser to plants would affect the rate of photosynthesis. For her experimental set-up, she added 10g of fertiliser to a plant with 70ml of water daily and put it in a well-lit place. Which one of the following plants is a suitable control for Mrs Ong's experiment?

	Plant P	Plant Q	Plant R	Plant S
Amount of light (lux)	0	5000	5000	3000
Amount of water (ml)	70	70	70	0
Amount of fertilizer (g)	10	0	5	0

- (1) Plant P
(2) Plant Q
(3) Plant R
(4) Plant S

18. The table shows how an orange indicator changes colour when the concentration of carbon dioxide in it changes.

Concentration of carbon dioxide	Change in colour
increases	orange to yellow
decreases	orange to purple

Adam set up an experiment shown below and placed the tube in a garden on a sunny day for a few hours.

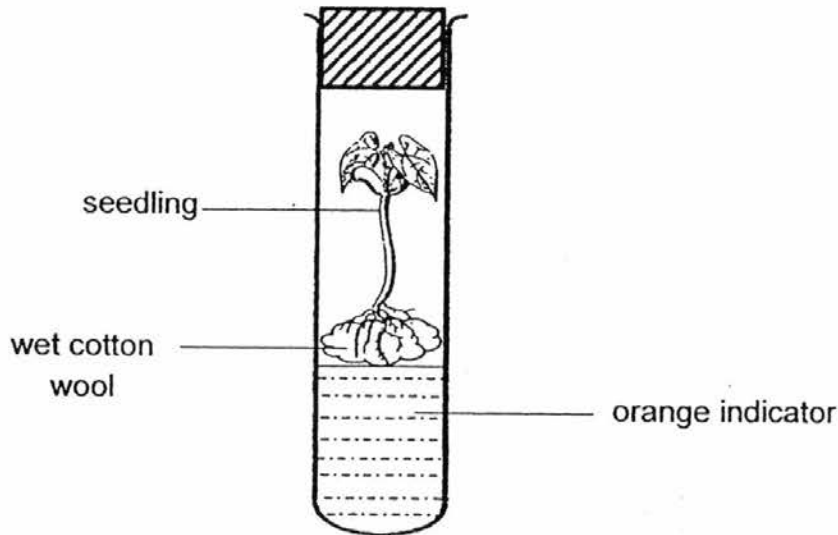

What would be the change in colour shown by the orange indicator after a few hours and what was the process that caused this change?

	Change in colour	Process
(1)	orange to yellow	respiration
(2)	orange to yellow	photosynthesis
(3)	orange to purple	photosynthesis
(4)	orange to purple	respiration

19. Ray fitted a flask with a glass tube that contained a drop of ink.

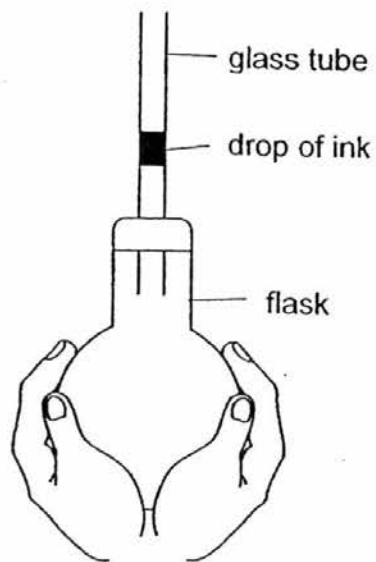

When Ray wrapped his hands around the flask, he noticed that the drop of ink moved upwards slightly.

Which of the following is the correct explanation for his observation?

- (1) The heat from his hand caused the flask to expand.
- (2) The heat from his hand caused the glass tube to expand.
- (3) The heat from his hand caused the drop of ink to expand.
- (4) The heat from his hand caused the air in the flask to expand.

20. Sam went for a picnic with 3 identical boxes, A, B and C, made of different materials. The table below shows the conductivity of heat of the three materials.

Box	Conductivity of heat
A	best conductor of heat
B	good conductor of heat
C	poor conductor of heat

If Sam was carrying hot pizzas in all 3 boxes, which of the following graphs would most likely represent the temperature change of the hot pizza in the 3 boxes after a few hours?

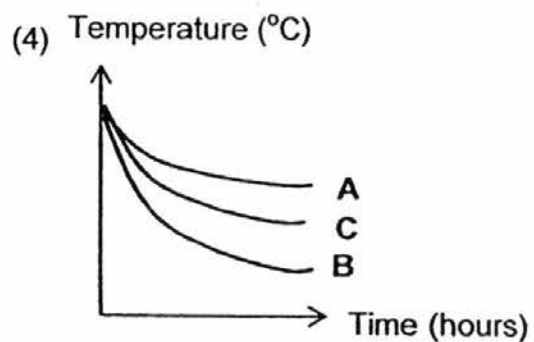
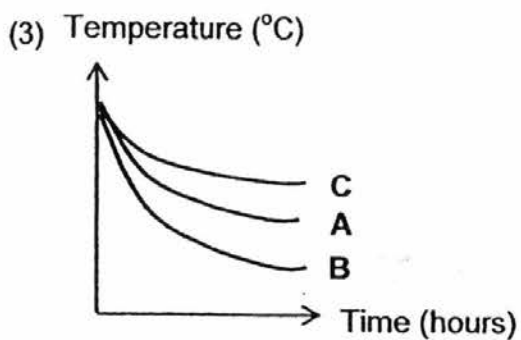
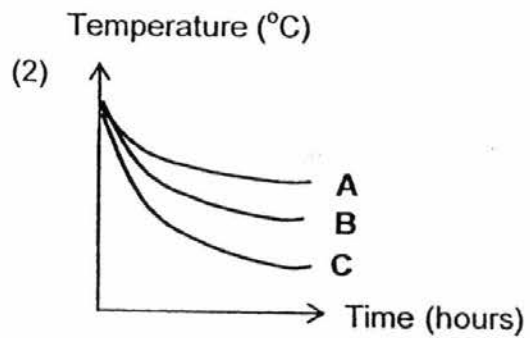
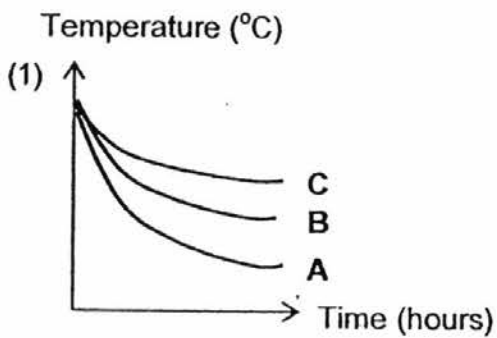

21. The diagrams below show four circuits. In which of the following circuits will the bulb light up?

(1)

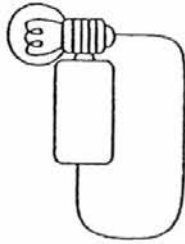

(2)

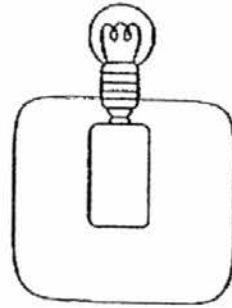

(3)

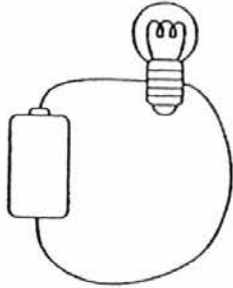

(4)

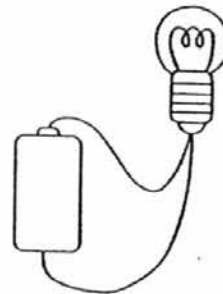

22. Study the electric circuit shown below.

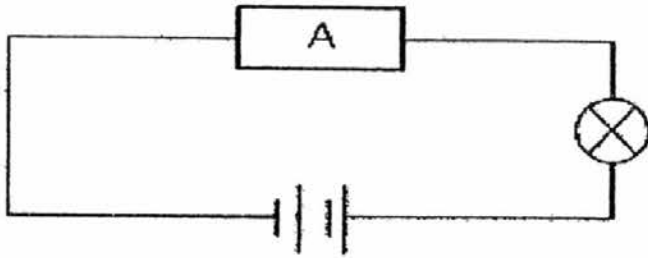

Melvin wants the light bulb to light up. Which one of the following materials would he use to make object A?

- | | |
|------------|-------------|
| (1) iron | (2) wood |
| (3) rubber | (4) ceramic |

23. Study the 4 circuit diagrams below.

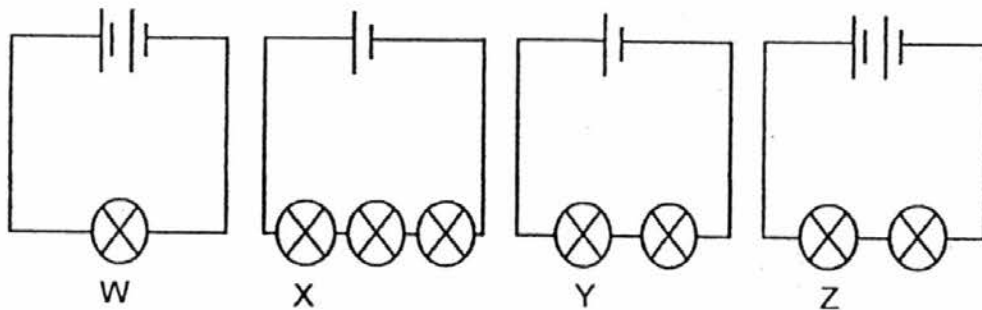

Arrange the bulbs W, X, Y and Z in each circuit from the dimmest to the brightest.

- | | |
|-------------------|-------------------|
| (1) X, Z, W and Y | (2) X, Y, Z and W |
| (3) W, Z, Y and X | (4) W, Y, Z and X |

24. Study the circuit below.

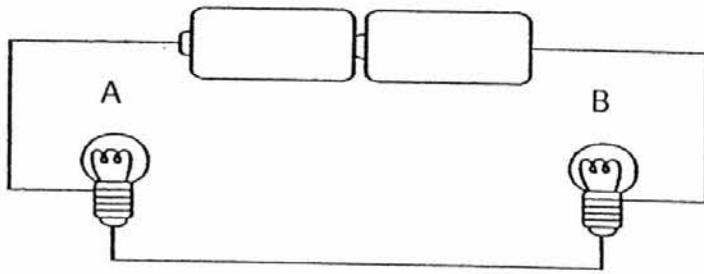

After 10 minutes, bulb A fused. Which of the following graphs will best represent the brightness of bulb B?

(1)

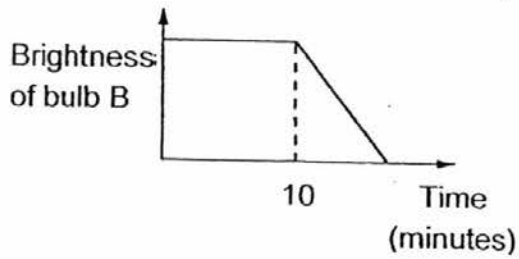

(2)

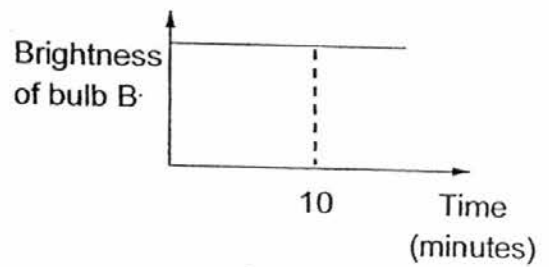

(3)

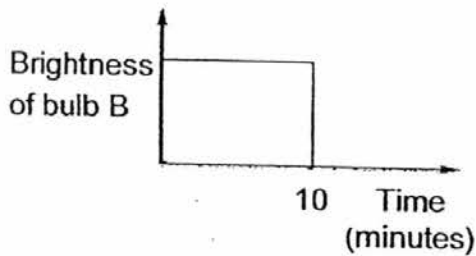

(4)

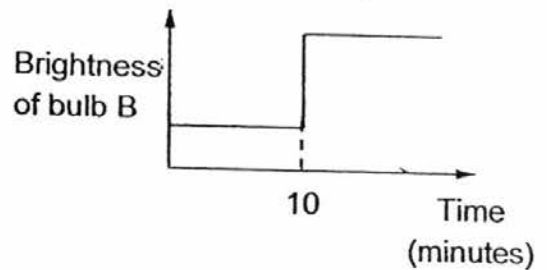

25. The diagram below shows the changes in the state of water.

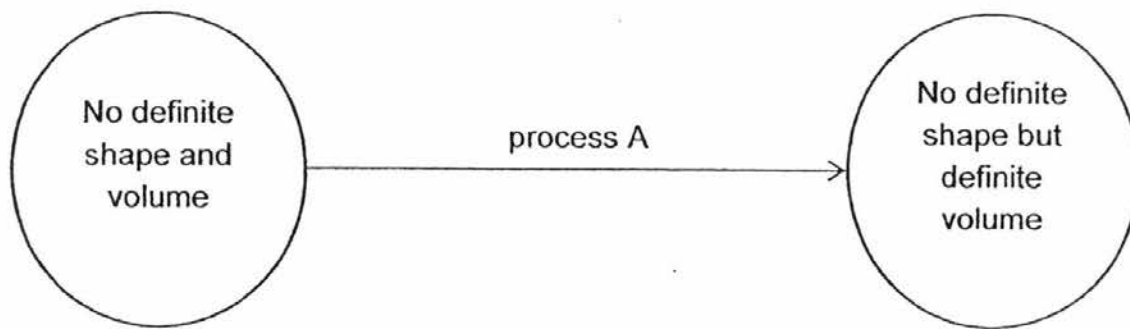

Which one of the following represents process A?

- | | |
|-----------------|------------------|
| (1) boiling | (2) melting |
| (3) evaporation | (4) condensation |
26. Jerome wanted to carry out an experiment to find out if the temperature of the water would affect the rate of evaporation of water in two containers. Which of the following variable(s) must he keep the same at the start of the experiment in order to ensure that his experiment is fair?
- A: temperature of water
B: size of the containers
C: amount of water in each container
- | | |
|------------------|------------------|
| (1) A only | (2) A and B only |
| (3) B and C only | (4) A, B and C |
27. Winona felt cold when she got out of the swimming pool. Why?
- (1) The water on her body evaporated into the surrounding air.
 - (2) The water in the swimming pool gained heat from her body.
 - (3) The water vapour from the surrounding air condensed onto her body.
 - (4) The water from the swimming pool evaporated into the surrounding air.

28. The diagram below shows three plastic containers A, B and C. An equal amount of water of the same temperature was poured into each container and kept at the same location.

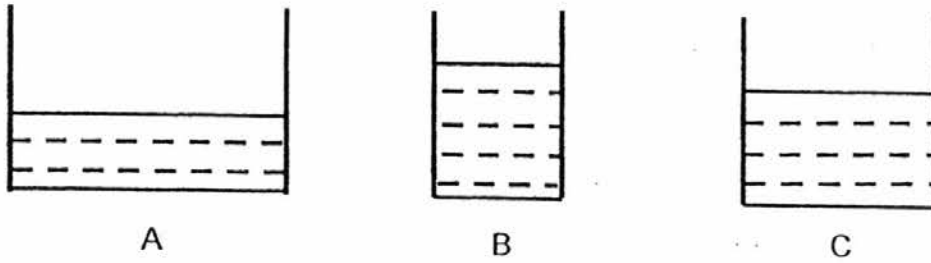

Which graph shows the amount of water left in the containers A, B and C after one day?

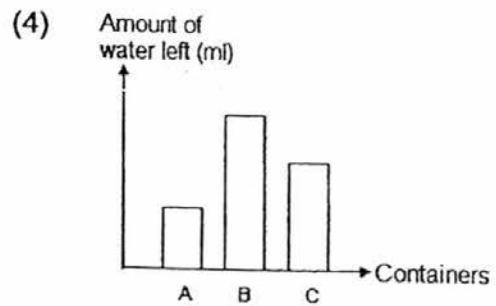
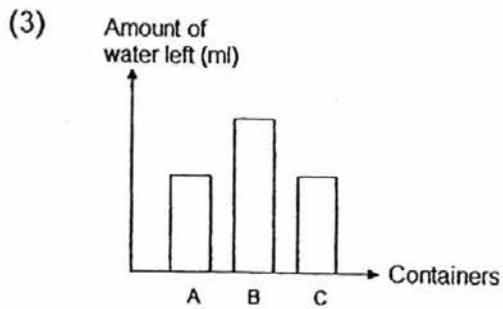
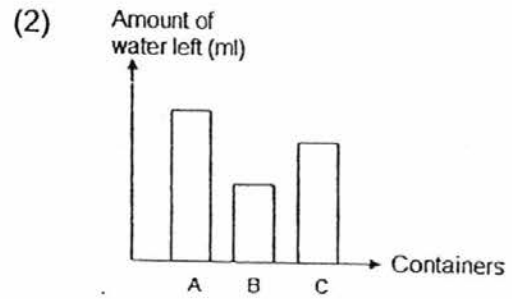
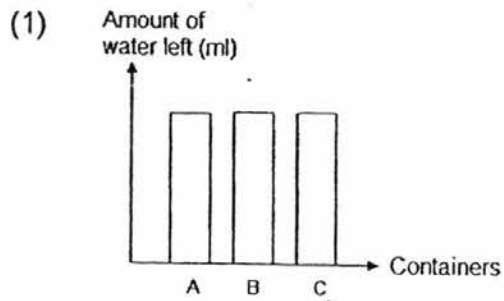



Rosyth School
Second Semestral Examination for 2016
STANDARD SCIENCE
Primary 5

Name: _____

Total
Marks:

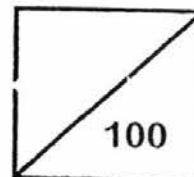

Class: Pr 5 - _____ Register No. _____ Duration: 1 h 45 min

Date: 1st Nov 2016

Parent's Signature: _____

Booklet B

Instructions to Pupils:

1. For questions 29 to 41, write your answers in the spaces given in this booklet.

	Maximum	Marks Obtained
Booklet A	56 marks	
Booklet B	44 marks	
Total	100 marks	

* This booklet consists of 17 printed pages (including cover page).

Part II

For questions 29 to 41, write your answers in this booklet.
The number of marks available is shown in brackets [] at the end of each question or part question. (44 mark)

29. The diagram below shows two plant cells.

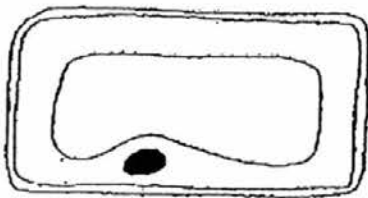

Cell A

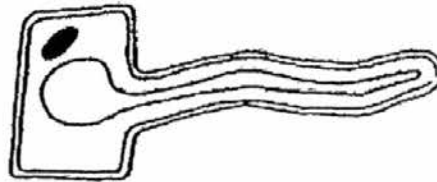

Cell B

- (a) Based on your observation above, state a similarity between Cell A and Cell B. (Do not compare shape and size) [1]

- (b) How are cells A and B different from a leaf cell? Explain your answer. [1]

30. The diagrams below show the life cycles of a frog and a mosquito.

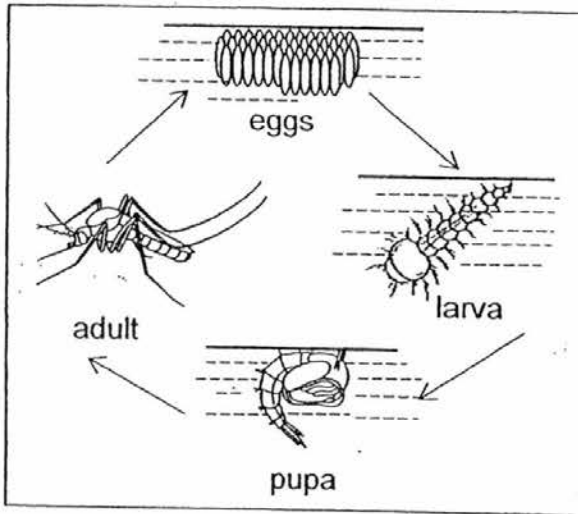

Life cycle of a mosquito

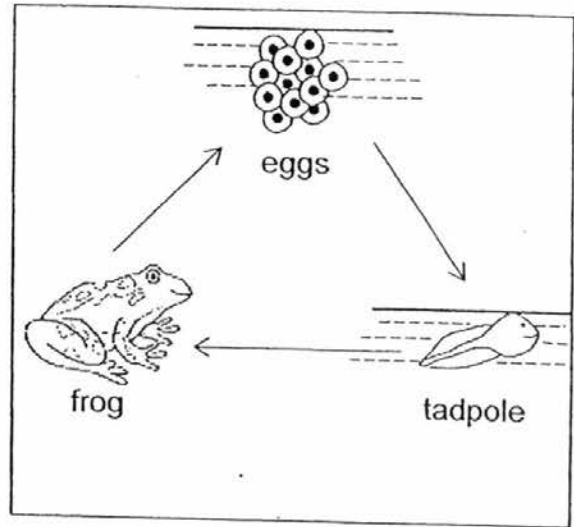

Life cycle of a frog

(a) State a difference between the two life cycles. [1]

(b) Why do frogs and mosquitoes lay many eggs at a time? [1]

Both the young of the frog and mosquito live in water while the adult lives on land.

(c) Suggest an advantage for the young and the adult to live in different places. [1]

(d) Will the life cycle of the mosquito and the frog be affected when the pond dries up due hot weather? Explain your answer. [1]

31. The diagram below shows the human digestive system.

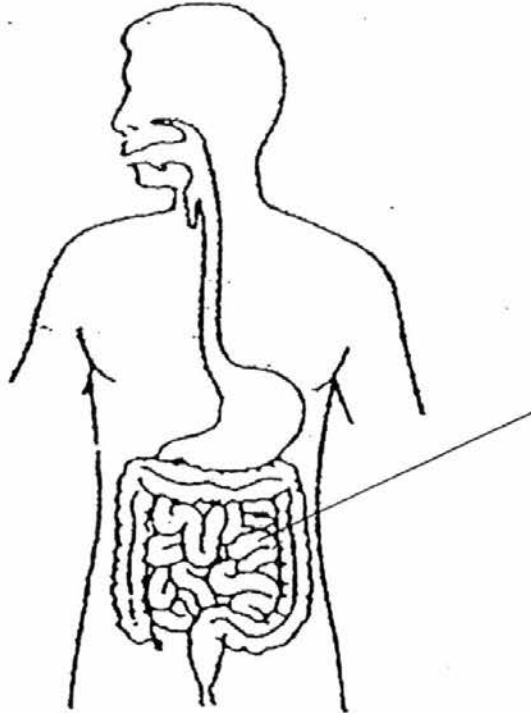

- (a) Draw a line and label the part of the system where most of the digested food is absorbed into the body. [1]
- (b) Describe how our digestive system and circulatory system work together to supply digested food to our body parts. [2]

32. Misha set up an experiment as shown below. She placed a stalk of celery in each jar. She poured an equal amount of blue-coloured water and oil into similar beakers R and H. She then placed the two beakers near a window.

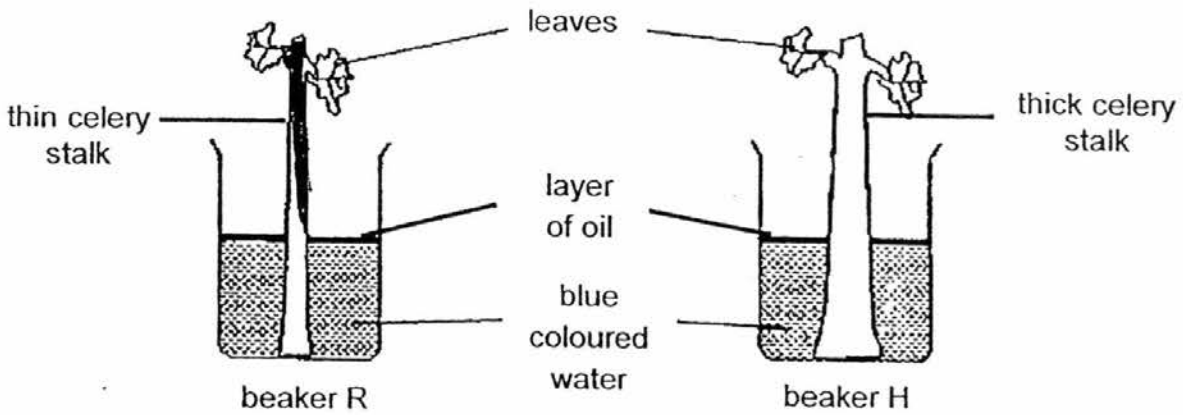

- (a) What is the purpose of putting a layer of oil in both beakers? [1]

The volume of water was observed and recorded daily over a period of 4 days and the results were drawn in the graph below.

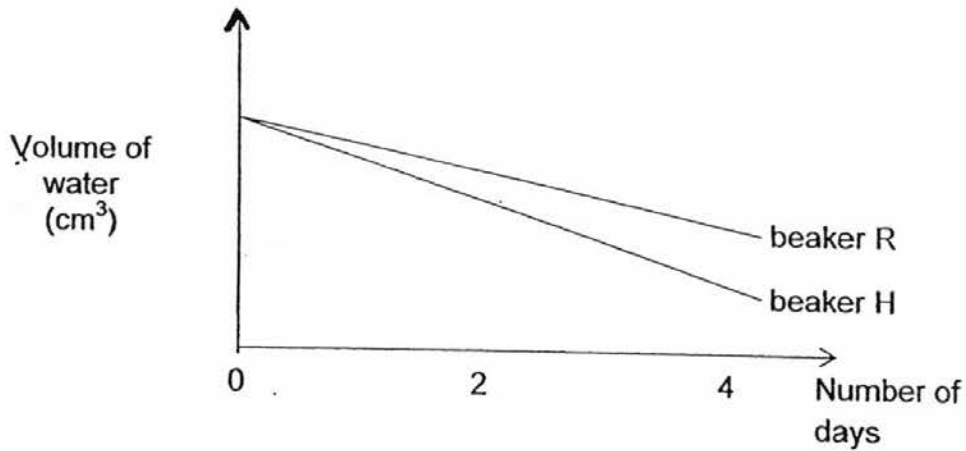

- (b) What was the aim of Misha's experiment? [1]

Question 32 continues on page 5

Misha decided to conduct another experiment using two similar thin celery stalks and placed each into similar beakers S and T as shown in the diagram below. The stem of the celery in beaker S was left uncut while the stem of the plant in beaker T was cut at a slanted angle before they were put in the respective beakers as shown.

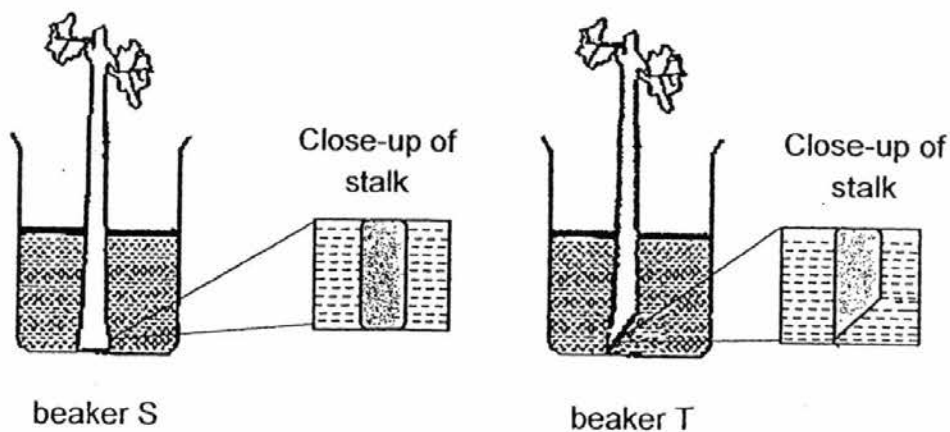

- (c) Would the decrease in volume of water in beaker T be larger or smaller than that obtained in beaker S? Explain your answer. [2]

33. Wendy carried out an experiment with a seed dispersed by wind in an enclosed room. She dropped the seed from various heights in front of a fan.

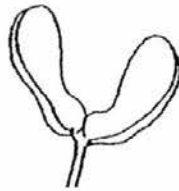

seed dispersed by wind

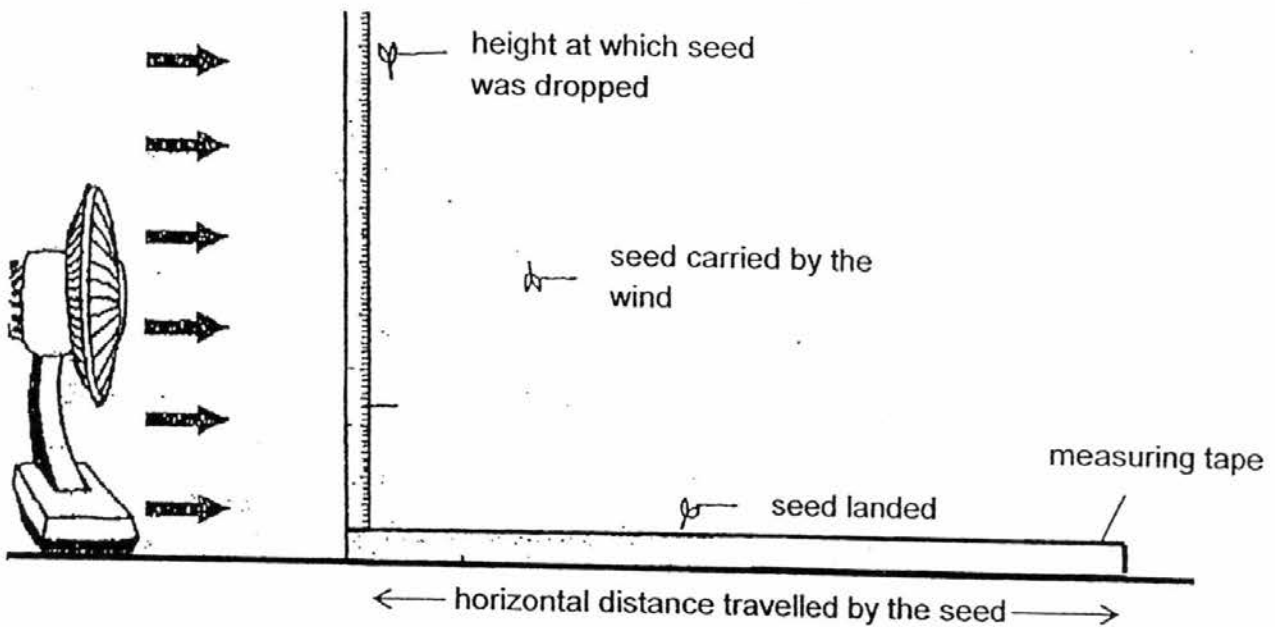

She recorded the horizontal distance travelled by the seed in a table as shown below.

Height at which seed was dropped (cm)	Horizontal distance travelled by seed (cm)			Average horizontal distance travelled by seed (cm)
	1 st reading	2 nd reading	3 rd reading	
5	7	12	11	10
15	27	29	34	30
25	49	54	47	50

Question 33 continues on page 7

- (a) Based on the results, what is the relationship between the height at which the seed was dropped and the average horizontal distance travelled by the seed? [1]

- (b) Why did Wendy take three readings of the horizontal distance travelled by the seed? [1]

- (c) State a feature of the seed that has helped it to be dispersed by wind. [1]

- (d) State a variable that Wendy has to keep the same to ensure that her experiment is a fair one. [1]

- (e) What is the advantage for plants to disperse their seeds as far away as possible from their parent plants? [1]

34. Kelly wanted to find out if light is needed for the germination of seeds. In set-up A, he placed three seeds on dry cotton wool. In set-up B, he placed three seeds on wet cotton wool and covered the dish with a dark cover. Both set-ups were put on a table.

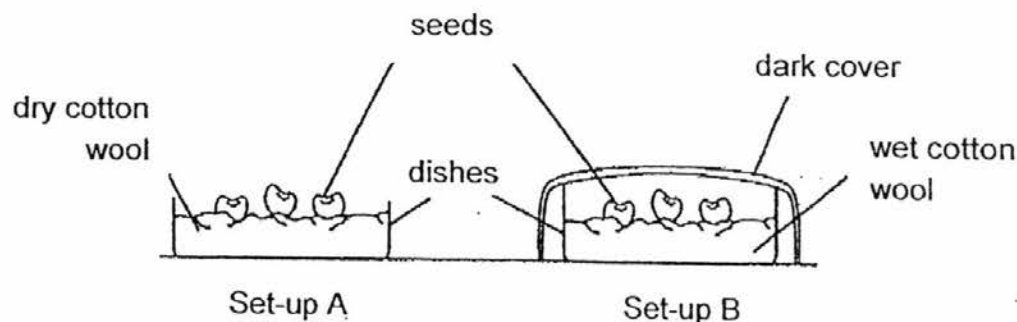

- (a) Kelly was told that her experiment was an unfair one. Suggest one change that Kelly can make to ensure that her experiment is a fair one. [1]

- (b) In which of the set-ups above would the seeds be able to germinate? Explain your answer. [1]

- (c) If Kelly wanted to find out if water is needed for the germination of seeds, what changes can she make to the set-up above? [1]

35. John conducted an experiment to find out how temperature affects the rate of photosynthesis of a water plant. He prepared several identical set-ups and placed each of them in rooms of different temperatures. All set-ups were exposed to the same amount of light.

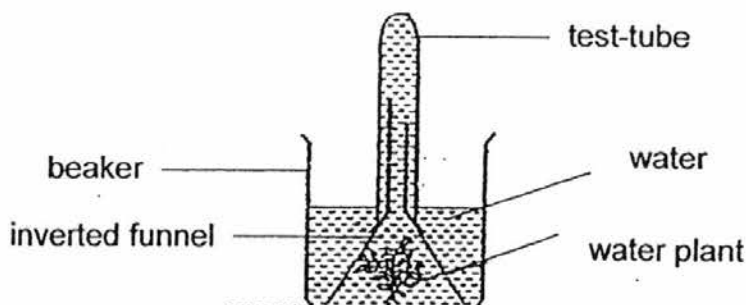

- (a) Tick the variable(s) to be kept constant in this experiment. [1]

Amount of water	<input type="checkbox"/>
Type of water plant	<input type="checkbox"/>
Temperature of water	<input type="checkbox"/>
Number of bubbles formed	<input type="checkbox"/>

At the end of the experiment, John recorded the amount of oxygen collected in the test-tube for each set-up. He plotted the following graph based on his results.

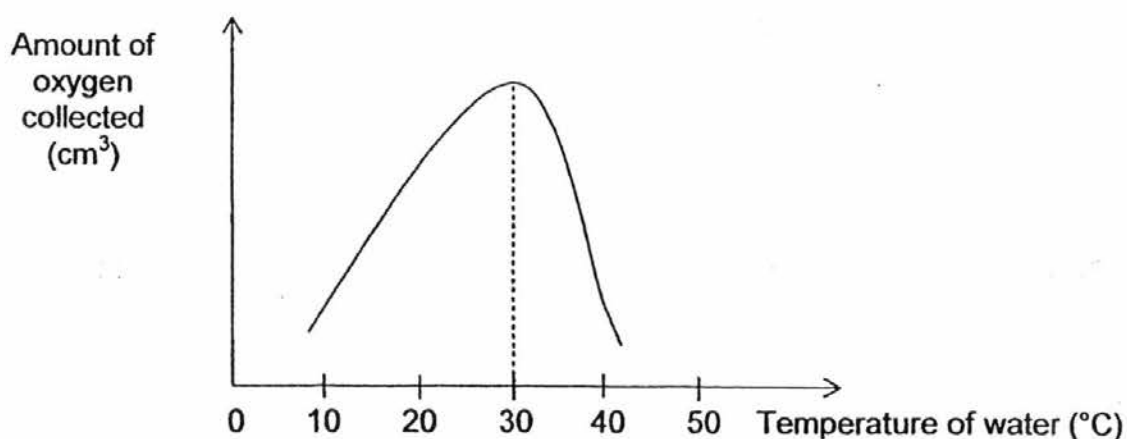

- (b) Based on the information above, what can John conclude about the effect of temperature of the water on the rate of photosynthesis of the water plant? [2]

36. Shanise set up an experiment to investigate the process of photosynthesis. She used a plant which had leaves with green areas in the middle and white areas around the edge as shown below. Before the experiment, the plant had been placed in the dark for three days. A plastic bag containing a substance that absorbs carbon dioxide was tied around leaf C.

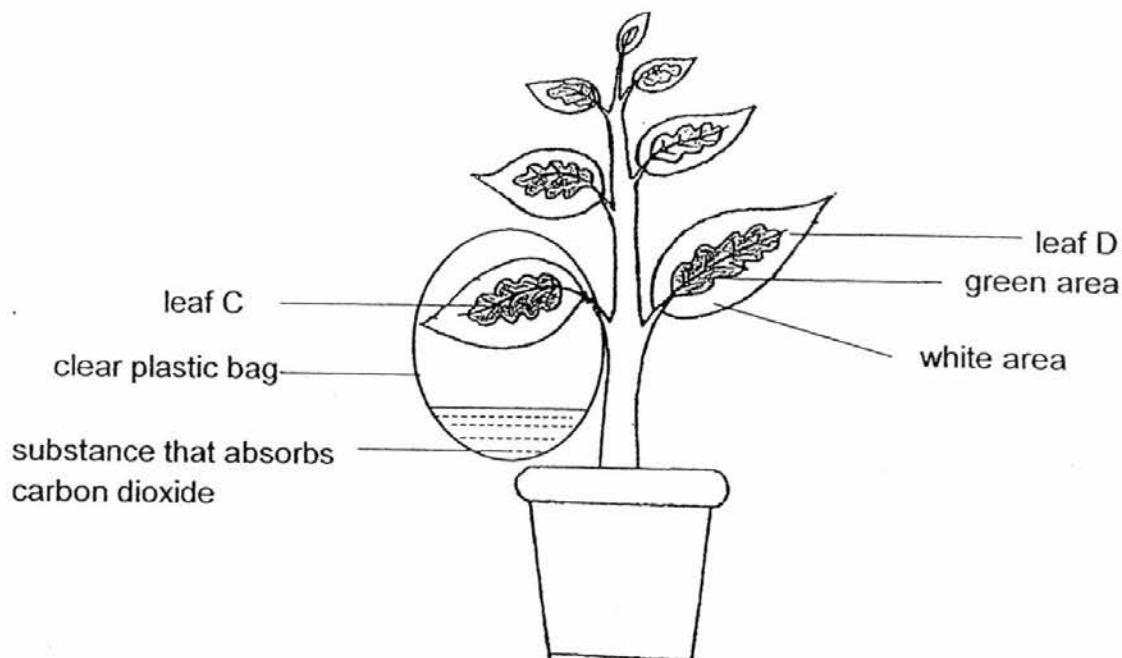

The experimental set-up was placed in the open area for a few days. Leaves C and D from the plant were then removed, prepared and tested with iodine solution. Iodine is a yellowish-brown liquid that turns dark blue in the presence of starch.

- (a) Complete the following table with the results you would expect to obtain for leaf C and D. [2]

		Results (Colour of iodine on leaf)	
	Leaf	Green area of leaf	White area of leaf
(i)	C		
(ii)	D		

- (b) Explain the results of the iodine colour on leaf D. [2]

37. Kumar set up an experiment as shown below. He used a straw to blow air into an inverted cup which was partially filled with water.

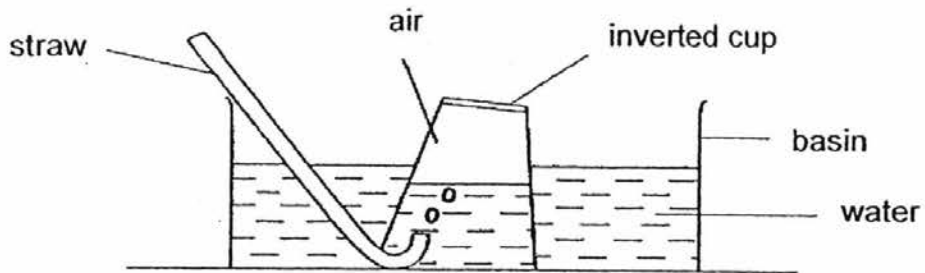

- (a) What would happen to the water level in the cup? [1]

- (b) Explain your answer in (a). [1]

Kumar used the same apparatus as above to carry out a second experiment. He removed the straw and made a hole at the base of the cup.

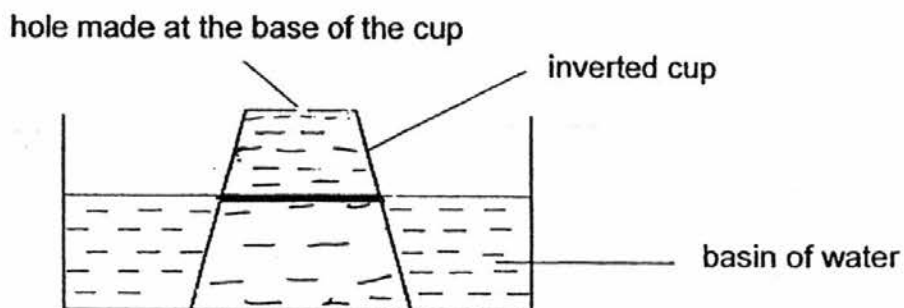

- (c) Draw the new water level in the inverted cup above. Explain why this happened. [2]

38. May set up a circuit as shown in the diagram below.

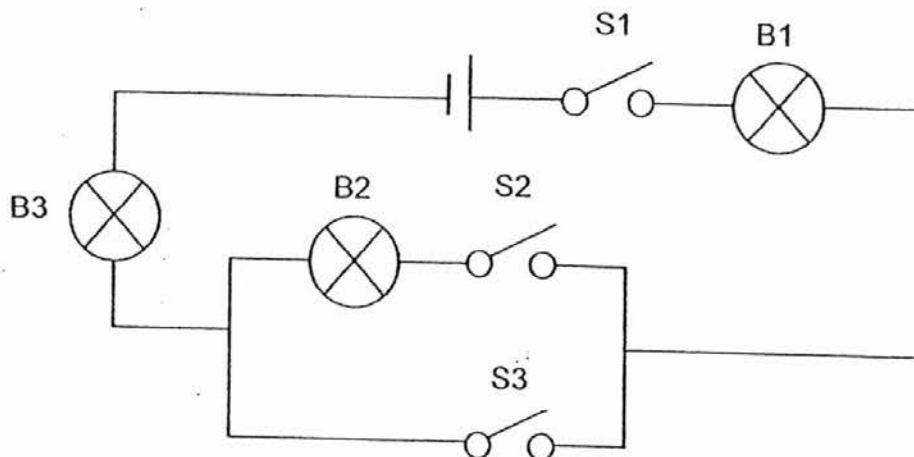

- (a) Which two switches must May close to ensure that all three light bulbs (B1, B2 and B3) would light up?

[1]

- (b) May closed switches S1 and S3. Would bulb B3 still light up if bulb B1 fused? Explain your answer.

[1]

39. Sue left a beaker of water with some ice cubes on the table. After a while, she noticed some water droplets on the outer surface of the beaker as shown in the diagram below.

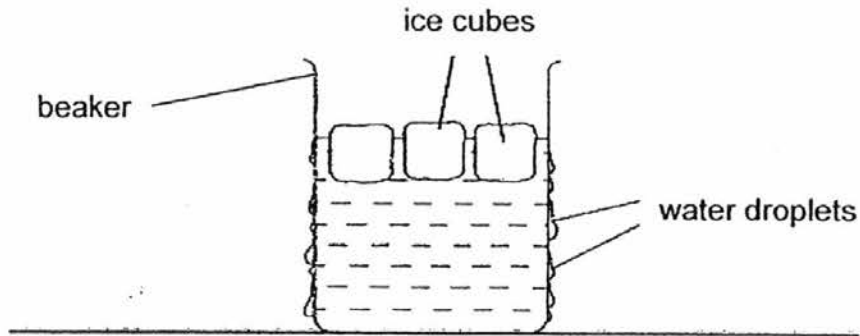

Explain why the water droplets are formed on the outer surface of the beaker.

[2]

40. Suzie wanted to investigate how the amount of heat gained would affect the state of water. She prepared two beakers, X and Y, and placed an equal number of ice cubes in each beaker.

She left beaker X in a room for 30 minutes. She left beaker Y on a stove until it reached the boiling point at the 20th minute. She continued to heat the water in Beaker Y until the 30th minute.

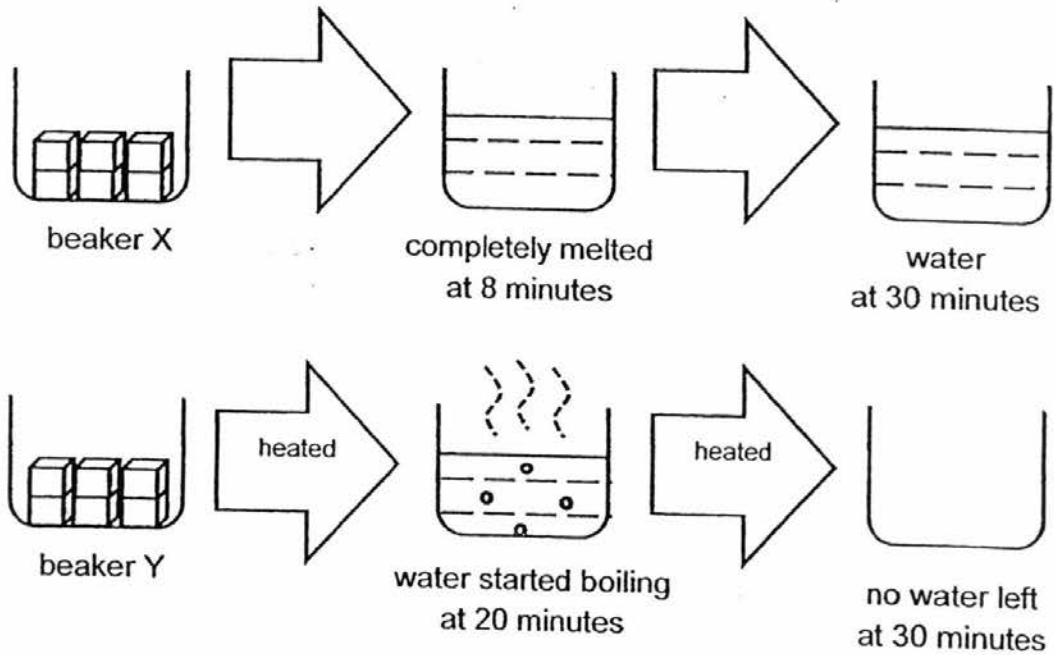

40
Question ~~44~~ continues on
page 15

The graph below shows the temperature of the contents in beakers X and Y over 30 minutes.

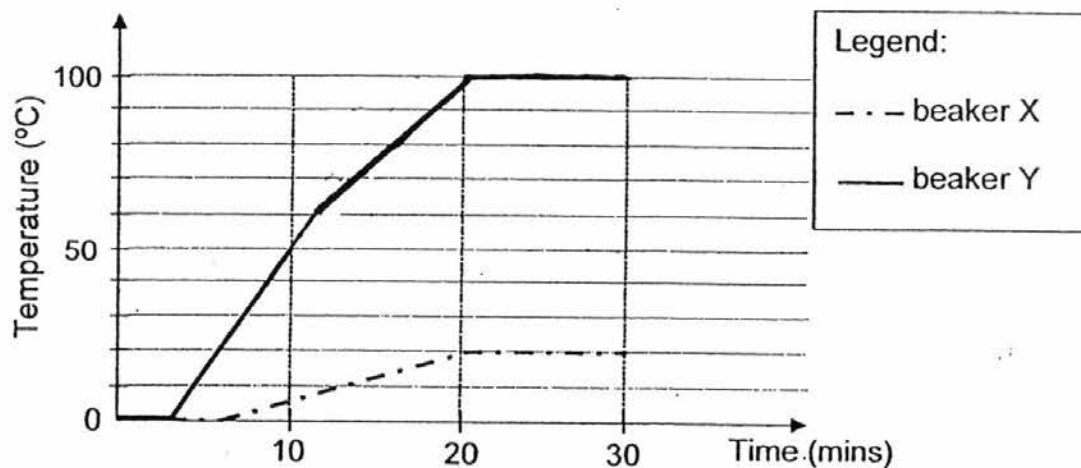

(a) In the graph above, complete the line for beaker Y to show the temperature change of the water till 30 minutes. [2]

(b) Based on the graph for beaker X, what is the room temperature? [1]
 _____ °C

(c) Explain your answer in (b). [1]

(d) Why was there no more water left in beaker Y at the 30th minute? [1]

41. Andy conducted an experiment using the set-up as shown below. He suspended an iron nail freely midway between steel rod X and Y. He used identical steel rods and identical new batteries for both circuits.

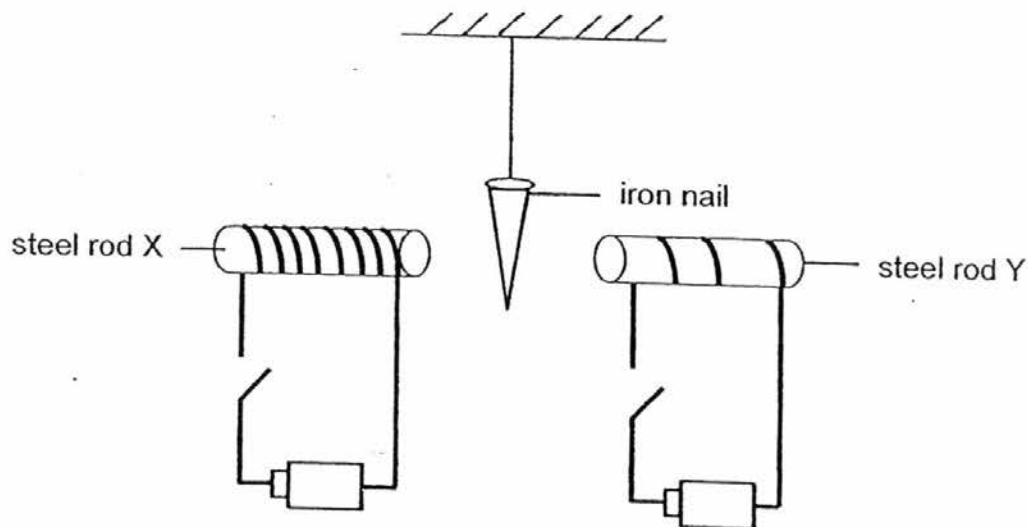

- (a) What will happen to the iron nail when both circuits are closed at the same time? [1]

- (b) Explain your answer in (a). [1]

- (c) Andy kept the distance between the iron nail and steel rods X and Y the same. Why does he have to do this in order to ensure a fair experiment? [1]

-End of Paper-

YEAR : 2016
LEVEL : PRIMARY 5
SCHOOL : ROSYTH
SUBJECT : SCIENCE
TERM : SA2

Booklet A

Q1	2	Q5	3	Q9	1	Q13	1	Q17	2	Q21	1	Q25	4
Q2	3	Q6	2	Q10	1	Q14	1	Q18	3	Q22	1	Q26	3
Q3	2	Q7	4	Q11	3	Q15	3	Q19	4	Q23	2	Q27	1
Q4	1	Q8	3	Q12	2	Q16	4	Q20	1	Q24	3	Q28	4

Booklet B

- Q29a Both have a nucleus.
- Q29b Both cells do not contain chloroplast as they do not need to make food.
- Q30a The life cycle of the frog has 3 stages but the life cycle of a mosquito has 4 stages.
- Q30b To increase the chances of survival.
- Q30c They do not have to compete for food.
- Q30d Yes, the eggs of both organisms cannot survive, causing fewer adults to continue the life cycle.

Q31a

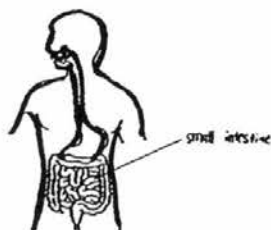

- Q31b The digestive system digests the food and the small intestine absorbs the digested food into the blood stream. The circulatory system then transports the digested food to all parts of our body.

- Q32a** To prevent the water from evaporating.
- Q32b** To find out how the thickness of the celery stalk affects the amount of water taken in by the plant.
- Q32c** The decrease in volume of water in beaker T would be larger than S as stalk T has a larger exposed surface area in contact with water.
- Q33a** As the height at which the seed was dropped increases, the average horizontal distance travelled by seed increases.
- Q33b** To ensure that the results are reliable.
- Q33c** It is light.
- Q33d** Amount of wind.
- Q33e** To prevent overcrowding so that they will have less competition for space, nutrients, water and sunlight.
- Q34a** Wet the cotton wool of set-up A.
- Q34b** B, it has air, water and warmth. Seeds need air, water and warmth to germinate.
- Q34c** Remove the dark cover of set-up B.

Q35a

Amount of water	✓
Type of water plant	✓
Temperature of water	
Number of bubbles formed	

- Q35b** As the temperature of water increases until 30°C, the rate of photosynthesis increases. As the temperature of water increases from 30°C onwards, the rate of photosynthesis decreases.

Q36a

Results (Colour of Iodine on leaf)			
	Leaf	Green area of leaf	White area of leaf
(i)	C	Yellowish-brown	Yellowish-brown
(ii)	D	Dark blue	Yellowish-brown

- Q36b** Leaf D could carry out photosynthesis at the green area as chlorophyll is present. As no chlorophyll present in the white area as it did not make food.

Q37a It will decrease.

Q37b The water exits and air if blown in takes up space.

Q37c The hole allowed air to escape, allowing the water to take up its space. Air has escaped from the cup and the water take up the space that was previously occupied air.

Q38a Switch S1 and S2

Q38b No, if bulb B1 fuses, there will be an open circuit gap in the circuit.

Q39 The water vapour from the surrounding air came into contact with the cooler surface. The water vapour lost heat and condensed to form water droplets.

Q40a

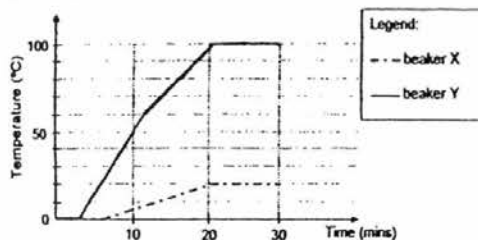

Q40b 20°C

Q40c There was no temperature change after 20 minutes.

Q40d All the water evaporated.

Q41a Steel rod X will attract the iron nail.

Q41b There were more coils around rod X, making the steel rod stronger.

Q41c To ensure that the number of coils around the steel rod is the only variable that affects the strength of the electromagnet.

End