



Rosyth School
Mid-Year Examination 2019
MATHEMATICS
Primary 5

Name: _____

Register No. _____

Class: Pr 5 - _____ Group: _____

Date: **15 May 2019**

Parent's Signature: _____

Total Time for Booklets A and B : 1 hour

**PAPER 1
(BOOKLET A)**

Instructions to Pupils:

1. Do not open this booklet until you are told to do so.
2. Follow all instructions carefully.
3. Shade your answers in the Optical Answer Sheet (OAS) provided.
4. You are **not** allowed to use a calculator.
5. Answer all questions.

Section	Maximum Mark	Marks Obtained
Paper 1 (Booklet A)	20	

* This booklet consists of 7 pages (including this cover page)

This paper is not to be reproduced in part or whole without the permission of the Principal.

Questions 1 to 10 carry 1 mark each. Questions 11 to 15 carry 2 marks each.
For each question, four options are given. One of them is the correct answer.
Make your choice (1, 2, 3 or 4). Shade the oval (1, 2, 3 or 4) on the Optical Answer Sheet.

All diagrams in this paper are not drawn to scale unless stated otherwise.

(20 marks)

1. In 1 529 067, the value of digit 2 is _____.

- (1) 20
- (2) 200
- (3) 2000
- (4) 20 000

2. Round 319 487 to the nearest thousand.

- (1) 319 000
- (2) 319 400
- (3) 320 000
- (4) 320 400

3. Find the value of $36\ 000 \div 400$.

- (1) 9
- (2) 90
- (3) 900
- (4) 9000

4. Which of the following has the same value as 6 041 702?

- (1) $6\ 000\ 000 + 4\ 000 + 100 + 70 + 2$
- (2) $6\ 000\ 000 + 40\ 000 + 100 + 70 + 2$
- (3) $6\ 000\ 000 + 40\ 000 + 1000 + 700 + 2$
- (4) $6\ 000\ 000 + 400\ 000 + 1000 + 700 + 2$

5. Sally has 24 bookmarks and Amy has 16 erasers. What is the ratio of the number of Amy's erasers to Sally's number of bookmarks?

- (1) 2 : 3
- (2) 3 : 2
- (3) 2 : 5
- (4) 3 : 5

6. The ratio of the number of ribbons to the number of hairclips that Lily bought is 6 : 7. Which of the following could be the number of ribbons and hairclips that Lily had bought?

	Ribbons	Hairclips
(1)	6	12
(2)	8	15
(3)	16	24
(4)	18	21

7. Express $3\frac{1}{4}$ as a decimal.

- (1) 3.14
- (2) 3.25
- (3) 3.41
- (4) 3.75

8. Which of the following represents the area of the triangle ABC shown below?

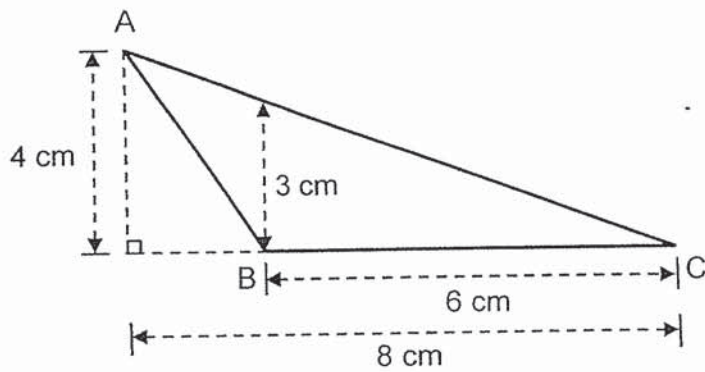

- (1) $\frac{1}{2} \times 6 \times 3$
 (2) $\frac{1}{2} \times 6 \times 4$
 (3) $\frac{1}{2} \times 8 \times 3$
 (4) $\frac{1}{2} \times 8 \times 4$

9. The diagram below shows some shapes. How many of these shapes contain at least one pair of parallel lines?

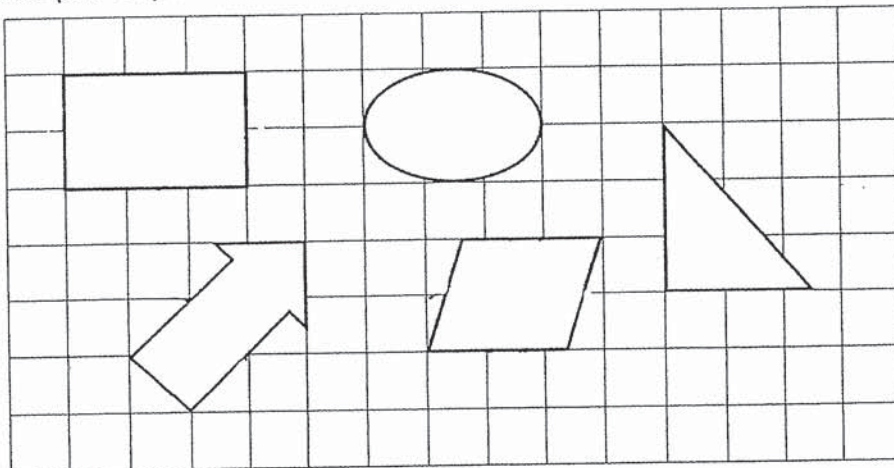

- (1) 5
 (2) 2
 (3) 3
 (4) 4

10. The table below shows the number of books read by some pupils in a class.

Number of books read by each pupil	0	1	2	3	4
Number of pupils	4	7	12	6	9

How many pupils read at least 2 books?

- (1) 12
(2) 15
(3) 23
(4) 27
11. Mrs Tan had 90 toys to sell at a fun fair event. The line graph below shows the number of toys in Mrs Tan's shop at the start of each day during the event.

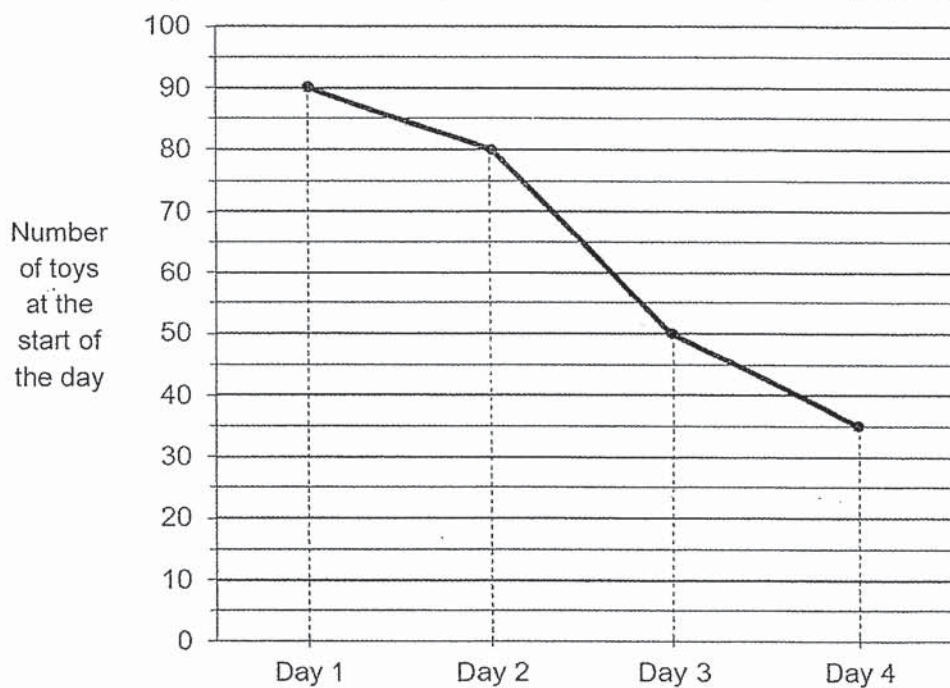

On which day did Mrs Tan sell the most number of toys?

- (1) Day 1
(2) Day 2
(3) Day 3
(4) Day 4

12. The figure below shows 1-cm unit cubes stacked against a corner. What is the least number of unit cubes that must be added to the figure to form a cube?

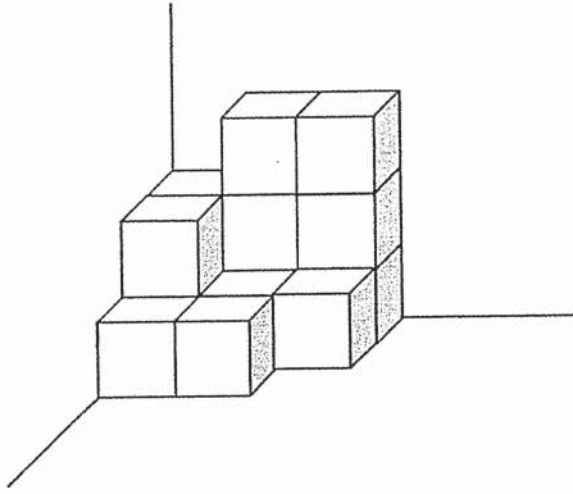

- (1) 11
(2) 12
(3) 13
(4) 14
13. Which of the following fractions is closest to 1?

- (1) $\frac{1}{3}$
(2) $\frac{3}{5}$
(3) $1\frac{2}{7}$
(4) $1\frac{2}{9}$

14. Albert, Ben and Charlie shared a sum of money in the ratio of 4 : 5 : 1. Charlie's share of the money was \$60 less than Albert's share of the money. What was the sum of money the three of them share?
- (1) \$120
 - (2) \$150
 - (3) \$200
 - (4) \$600
15. The ratio of the number of students in the chess club to the number of students in the robotics club is 5 : 7. The ratio of the number of students in chess club to the number of students in the art club is 5 : 2. There are 30 students in the chess club. How many more students are there in the robotics club than the art club?
- (1) 12
 - (2) 22
 - (3) 30
 - (4) 60



Rosyth School
Mid-Year Examination 2019
MATHEMATICS
Primary 5

Name: _____

Register No. _____

Class: Pr 5 - _____ Group: _____

Date: 15 May 2019

Parent's Signature: _____

Total Time for Booklets A and B : 1 hour

PAPER 1
(BOOKLET B)

Instructions to Pupils:

1. Do not open this booklet until you are told to do so.
2. Follow all instructions carefully.
3. You are **not** allowed to use a calculator.
4. Write your answers in the booklet.
5. Answer all questions.

Section	Maximum Mark	Marks Obtained
Paper 1 (Booklet B)	25	

* This booklet consists of 8 pages (including this cover page)

Questions 16 to 20 carry 1 mark each. Write your answers in the spaces provided.
For questions which require units, give your answers in the units stated.

Do not write
in this space

All diagrams in this paper are not drawn to scale unless stated otherwise.
(5 marks)

16. There are 150 paper clips in a box.
How many paper clips will there be in 60 boxes?

Ans: _____

17. Kumar bought 10 pens and 4 notebooks. After that, he gave 2 pens to his sister.
Then his brother gave him 3 notebooks. What was the ratio of the number of pens to the number of notebooks Kumar had in the end?

Ans: _____

18. Find the value of $2\frac{3}{10} - \frac{2}{5}$. Give your answer in the simplest form.

Ans: _____

19. How much water is there in the beaker? Give your answers in millilitres.

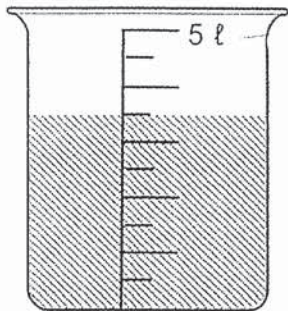

Do not write
in this space

Ans: _____ ml

20. The graph below shows the number of watches sold from March to June. The number of watches sold in June is twice the number of watches sold in April. Draw the bar for June in the graph.

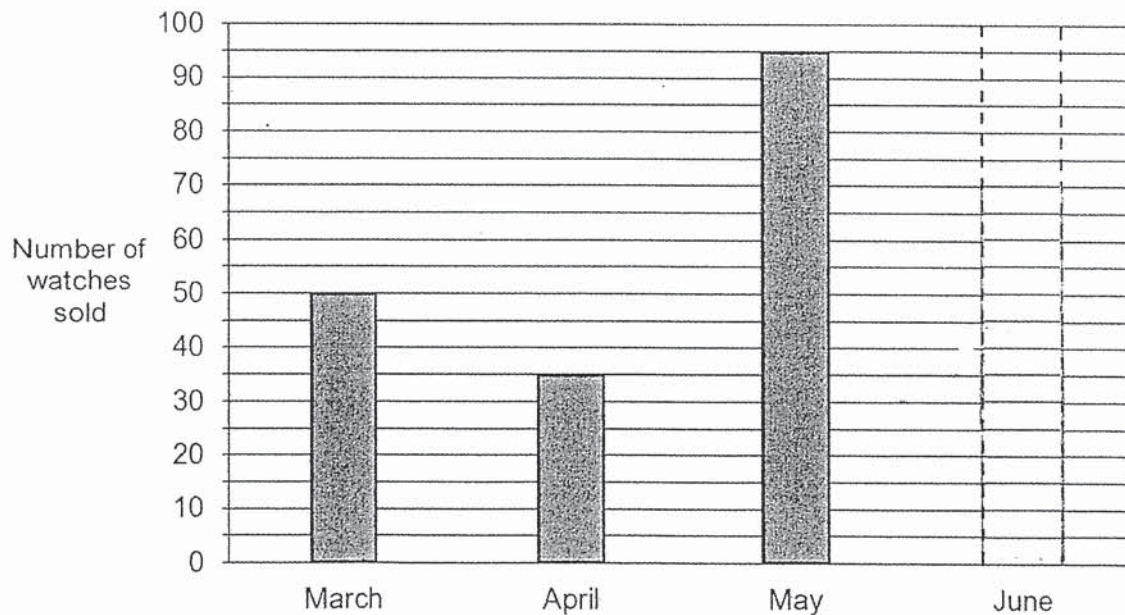

Questions 21 to 30 carry 2 marks each. Show your workings clearly in the space provided for each question and write your answers in the spaces provided. For questions which require units, give your answers in the units stated.

Do not write
in this space

All diagrams in this paper are not drawn to scale unless stated otherwise.
(20 marks)

21. Find the value of $200 - 80 \times 2 + 10$.

Ans: _____

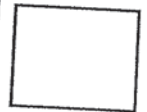

22. Sarah can pack at most 4 muffins in a box. She needs to pack all 146 muffins in such boxes. What is the least number of boxes that she will need to pack all the muffins?

Ans: _____

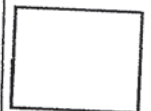

23. The diagram below shows a square ABCD. The ratio of the area of triangle ABE to the area of triangle BEC is 3 : 7. The area of triangle ABE is 15 cm². What is the length of the square ABCD?

Do not write
in this space

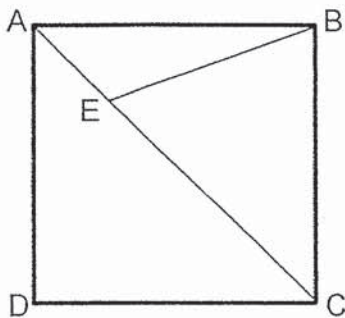

Ans: _____ cm

24. Chloe had $\frac{9}{10}$ m of a ribbon. She gave $\frac{5}{12}$ of it to Devi. What was the length of the ribbon that Devi got? Give your answer in the simplest form.

Ans: _____ m

25. Joel arranged 6 identical rectangles as shown in Figure A. She then rearranged the 6 rectangles as shown in Figure B. What is the perimeter of Figure B?

Do not write in this space

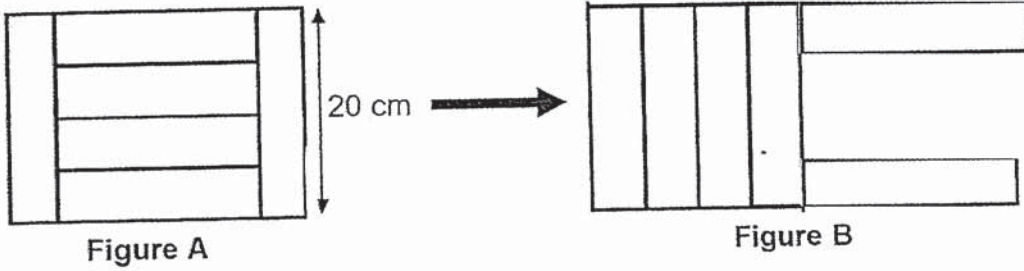

Ans: _____ cm

26. A rectangular piece of paper was folded into the shape shown below. Find the area of the piece of paper before it was folded.

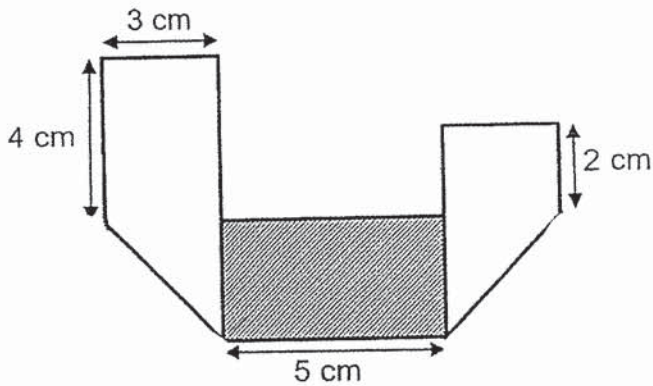

Ans: _____ cm²

27. The diagram below shows a part of the symmetrical figure.
Shade the least number of squares to make the figure symmetrical.

Do not write in this space

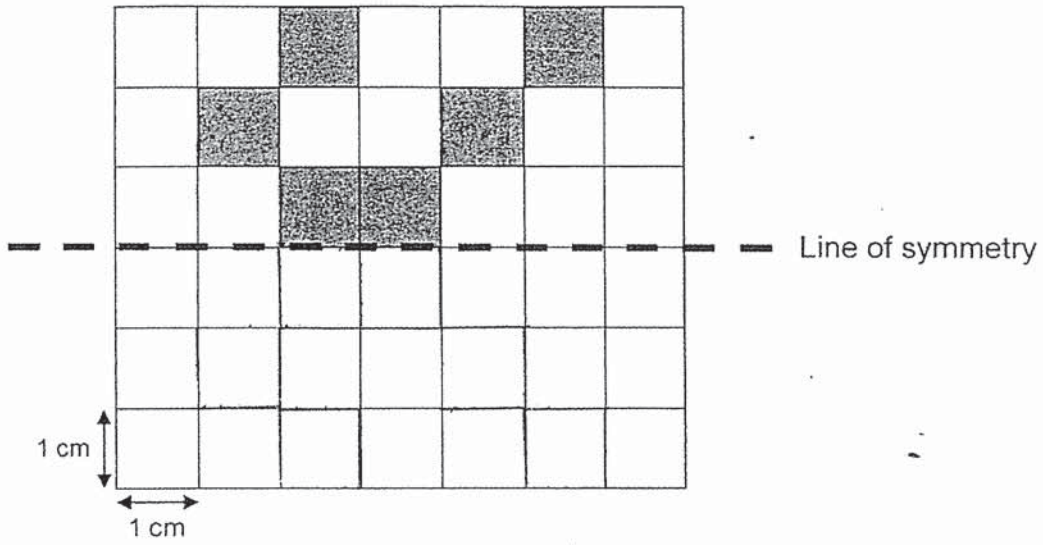

28. In the diagram below, draw a line that is parallel to line AB and passes through point Z.

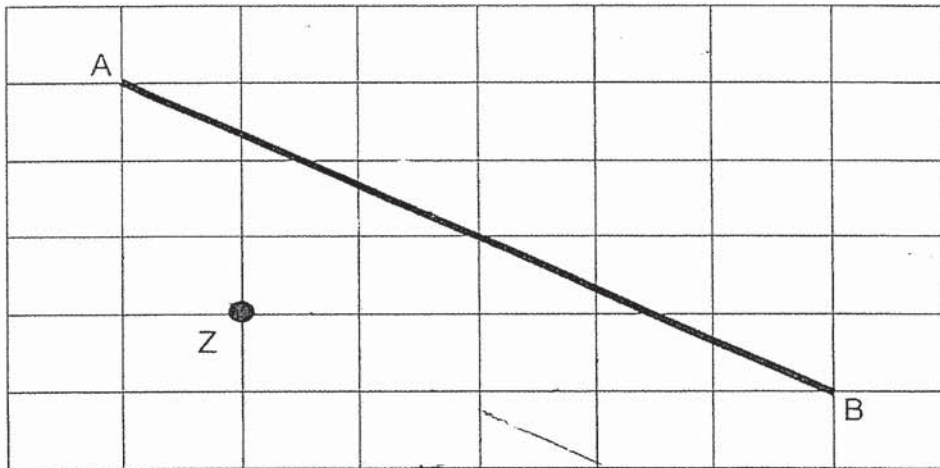

29. A bag costs \$10 more than a cap and twice as much as the cost of a t-shirt. The total cost of the bag, cap and t-shirt is \$120. How much more does the cap cost than the t-shirt?

Do not write in this space

Ans: \$ _____

30. Rectangle ABCD is made up of 4 squares and 2 triangles. What fraction of the Rectangle ABCD is shaded? Give your answer in the simplest form.

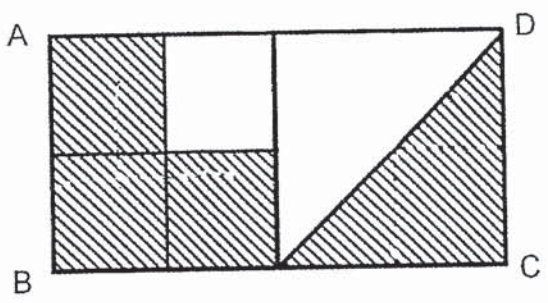

Ans: _____

End of paper
Have you checked your work?



Rosyth School
Mid-Year Examination 2019
MATHEMATICS
Primary 5

Name: _____

Register No. _____

Class: Pr 5 - _____ Group: _____

Date: 15 May 2019

Parent's Signature: _____

Time: 1 h 30 min

PAPER 2

Instructions to Pupils:

1. Do not open this booklet until you are told to do so.
2. Follow all instructions carefully.
3. **Show your workings clearly** as marks are awarded for correct working.
4. Write your answers in this booklet.
5. You are allowed to use a calculator.
6. Answer all questions.

Questions	Maximum Mark	Marks Obtained
Q 1 to 5	10	
Q 6 to 17	45	

Section	Maximum Mark	Marks Obtained
Paper 1	45	
Paper 2	55	
Total	100	

* This booklet consists of 14 pages (including this cover page)

Questions 1 to 5 carry 2 marks each. Show your working clearly in the space provided for each question and write your answers in the spaces provided. For questions which require units, give your answers in the units stated.

Do not write
in this space

All diagrams in this paper are not drawn to scale unless stated otherwise.

(10 marks)

1. Mrs Tan used 800 g of flour to make some cupcakes. Mdm Ramah used 500 g more than Mrs Tan. Mdm Shamini used twice as much flour as Mdm Ramah. How many grams of flour did Mdm Shamini use?

Ans: _____ g

2. Ken, Tammy and Rishi used some straws to make a structure each. Tammy used 12 fewer straws than Ken. Rishi used 20 more straws than Ken. The three children used 284 straws altogether. How many straws did Rishi use?

Ans: _____

Do not write
in this space

3. Mrs Tan had $4\frac{5}{7}$ kg of sugar. She used $\frac{2}{11}$ of the sugar to bake cookies and gave away $\frac{1}{2}$ kg of sugar to charity. How much sugar did she have left?
Give your answer as a mixed number in the simplest form.

Ans: _____ kg

4. The base of a cuboid is a square of side 9 cm. The height of the cuboid is 15 cm. Find the volume of the cuboid.

Ans: _____ cm³

5. Mr Goh's monthly salary is \$1500. The bar graph below shows Mr Goh's savings from January to April.

Do not write in this space

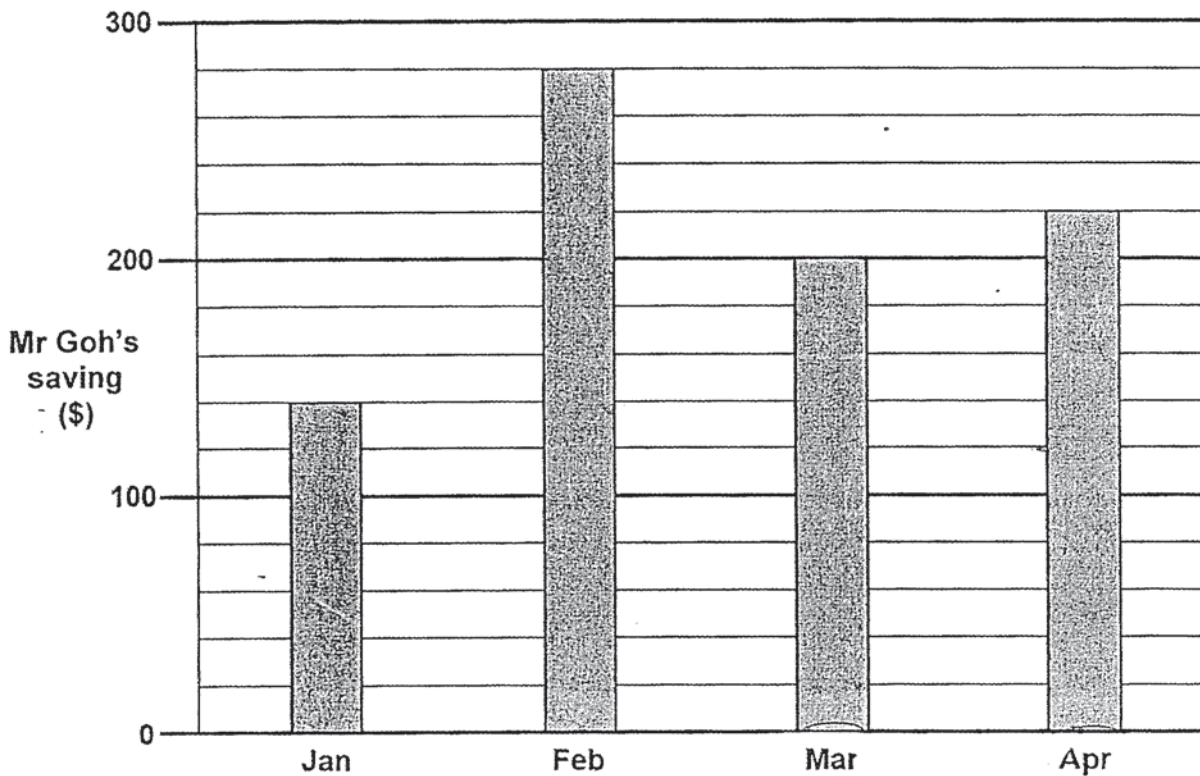

Each statement below is either true, false or not possible to tell from the information given. For each statement, put a tick (✓) in the correct column.

Statement	True	False	Not possible to tell
(a) Mr Goh spent the most in the month of January.			
(b) Mr Goh saved \$410 altogether in the month of March and April.			

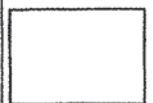

For Questions 6 to 17, show your working clearly in the space provided for each question and write your answers in the spaces provided. The number of marks available is shown in brackets [] at the end of each question or part-question. For questions which require units, give your answers in the units stated.

Do not write in this space

All diagrams in this paper are not drawn to scale unless stated otherwise.

(45 marks)

6. There were twice as many adults as children in a concert. $\frac{1}{5}$ of the children were girls and the rest were boys. There were 240 more adults than boys. How many people were there at the concert?

Ans: _____ [3]

7. Find the area of the shaded parts in Triangle XYZ.

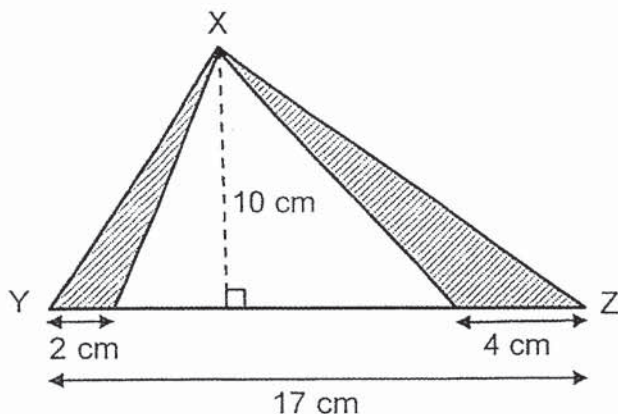

Ans: _____ [3]

8. Draw the different views of the solid shown below in the grid square provided.

Do not write in this space

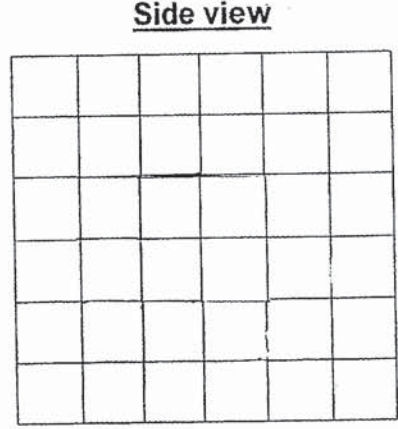
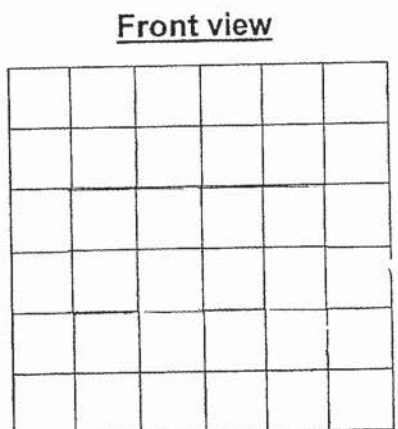
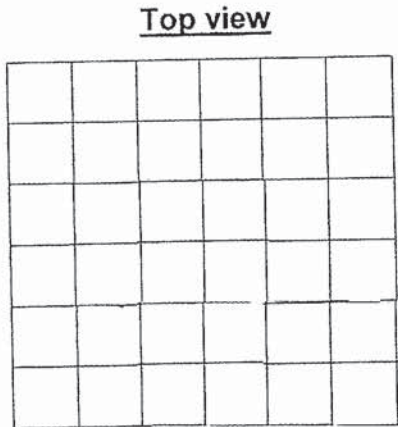
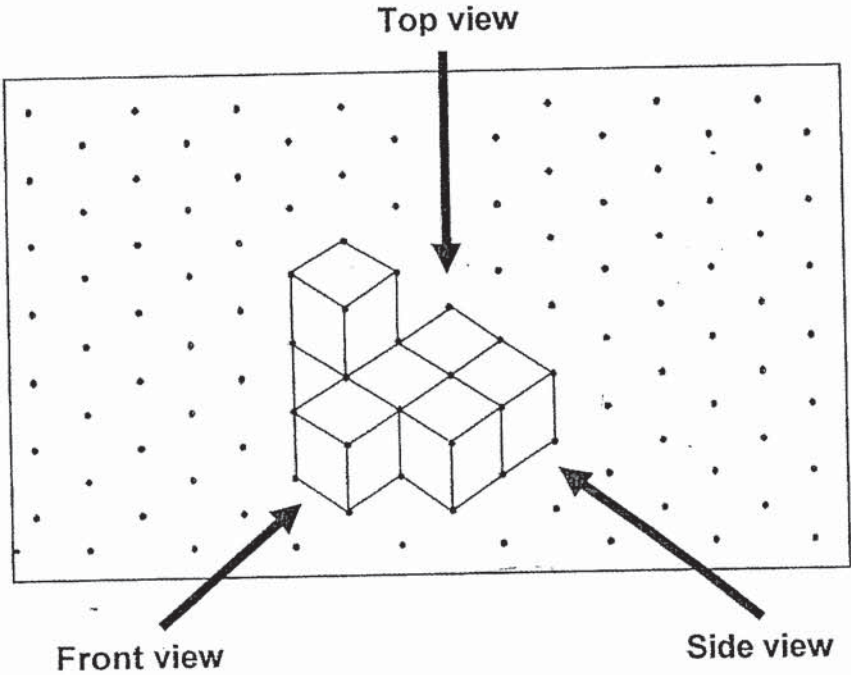

[3]

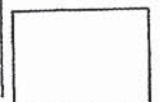

9. The ratio of the number of cats to the number of rabbits to the number of dogs in an animal adoption centre is $6 : 5 : 13$. There are 32 more dogs than the total number of cats and rabbits at the centre. How many cats, rabbits and dogs are there altogether?

Do not write
in this space

Ans: _____ [3]

10. Jerry had some money. After spending \$200 on a watch and $\frac{2}{7}$ of his remaining money on a shirt, he had $\frac{1}{3}$ of the total amount of money left. How much money did he have at first?

Ans: _____ [3]

11. Amy, Brina and Cindy shared \$370. After Amy gave \$48 of her money to Brina, Amy's money became thrice of Brina's money. Cindy had \$60 more than Brina in the end.

(a) How much money did Brina have at first?

(b) How much money did Cindy have?

Do not write
in this space

Ans: (a) _____ [2]

(b) _____ [2]

Do not write
in this space

12. Ricky has thrice as many stickers as Hamid. The total number of stickers that Ricky and Hamid have is half of the number of stickers that Liming has. Liming has 60 stickers more than Benny. All the four boys have a total of 300 stickers.

- (a) How many stickers does Hamid have?
- (b) How many more stickers does Benny have than Ricky?

Ans: (a) _____ [2]

(b) _____ [2]

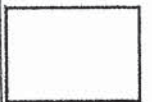

13. Mary bought an equal number of pies and curry puffs. She spent \$26 on buying the pies and curry puffs. How many pies did she buy?

Do not write
in this space

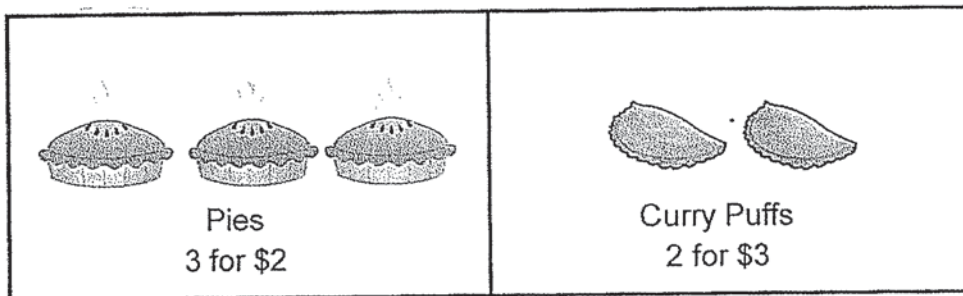

Ans: _____ [4]

14. A piece of paper is made up of square ABCD and rectangle CDEF. Square ABCD and Rectangle CDEF are folded to form the figure as shown below. The length of Rectangle CDEF is twice its breadth. DG is 16 cm. Find the area of the shaded folded figure.

Do not write in this space

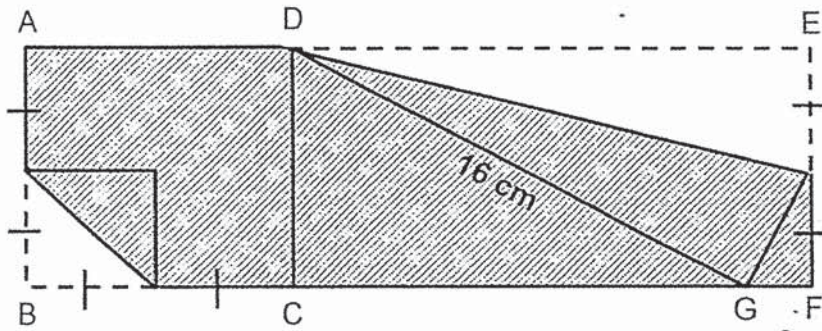

Ans: _____ [4]

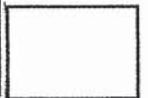

15. 2 identical notebooks cost as much as 5 identical files. Peter bought 6 such notebooks and 7 such files for \$74.80. What was the total cost of 1 notebook and 1 file?

Do not write
in this space

Ans: _____ [4]

16. In January, , Mark and Kelly received a total of \$192 pocket money from their mother. Mark's pocket money was twice of Kelly's pocket money. In February, their mother gave Kelly an additional \$40.

Do not write
in this space

- (a) What was Mark's pocket money?
- (b) How much must Mark give to Kelly so that each of them has the same amount of pocket money in February?

Ans: (a) _____ [2]

(b) _____ [3]

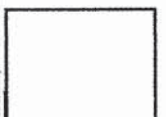

17. Company Kovan has 40 workers and 1 manager. Each worker contributed \$28 towards a party. The ratio of the amount of money contributed by one worker to the amount of money contributed by the manager is 7 : 11. $\frac{1}{2}$ of the total amount of money contributed was spent on food, $\frac{1}{6}$ of the total amount of money contributed was spent on decoration. After spending \$95 on drinks and some money on prizes, there was \$43 left.

- (a) What was the total amount of money contributed?
- (b) How much money was spent on the prizes?

Do not write
in this space

Ans: (a) _____ [2]

(b) _____ [3]

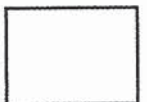

End of paper
Have you checked your work?

ANSWER KEY

YEAR : 2019
LEVEL : PRIMARY 5
SCHOOL : ROSYTH
SUBJECT : MATHEMATICS
TERM : SA1

PAPER 1 : BOOKLET A

Q1	Q2	Q3	Q4	Q5	Q6	Q7	Q8
4	1	2	3	1	4	2	2
Q9	Q10	Q11	Q12	Q13	Q14	Q15	
3	4	2	3	4	3	3	

PAPER 1 : BOOKLET B

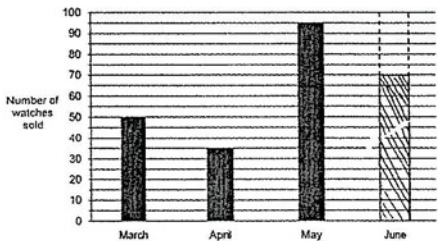
Q16	$150 \times 6 = 9\ 000$										
Q17	$10 - 2 : 4 + 3 \rightarrow 8 : 7$										
Q18	$\frac{23}{10} - \frac{4}{10} = 1\frac{9}{10}$										
Q19	$3.5\ L = 3500\text{ml}$										
Q20	 <table border="1" style="margin-top: 10px; width: 100%; text-align: center;"> <caption>Number of watches sold</caption> <thead> <tr> <th>Month</th> <th>Number of watches sold</th> </tr> </thead> <tbody> <tr> <td>March</td> <td>50</td> </tr> <tr> <td>April</td> <td>35</td> </tr> <tr> <td>May</td> <td>95</td> </tr> <tr> <td>June</td> <td>70</td> </tr> </tbody> </table>	Month	Number of watches sold	March	50	April	35	May	95	June	70
Month	Number of watches sold										
March	50										
April	35										
May	95										
June	70										
Q21	$200 - (80 \times 2) + 10$ $= 200 - 160 + 10$ $= 50$										
Q22	$146 \div 4 = 36\ R\ 2$ Ans : 37										
Q23	$ABE : BEC : ACD = 3 : 7 : 10$ $300 \rightarrow 15\text{cm}^2$ $\rightarrow 15 \div 3 \times 20 = 100\text{cm}^2$ $\bar{0} = 10\text{cm}$										
Q24	$\frac{5}{12} \times \frac{9}{10} = \frac{45}{120} = \frac{3}{8}$										
Q25	Breadth $\rightarrow 20 \div 4 = 5\text{cm}$ Length $\rightarrow 20\text{cm}$ Total $\rightarrow 20 + 20 + 20 + 5 + 20 + 10 + 20 + 5 + 20 + 20 = 160$										
Q26	Breadth $\rightarrow 3\text{cm}$ Length $\rightarrow 4 + 3 + 5 + 3 + 2 = 17\text{cm}$ Area $\rightarrow 17 \times 3 = 51\text{cm}^2$										

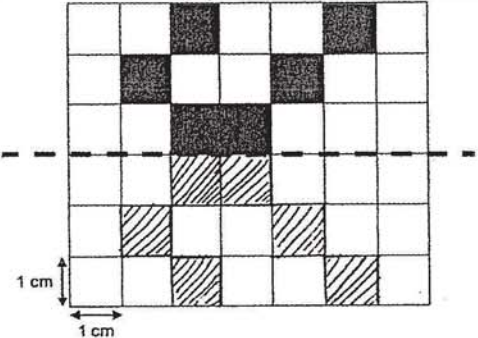
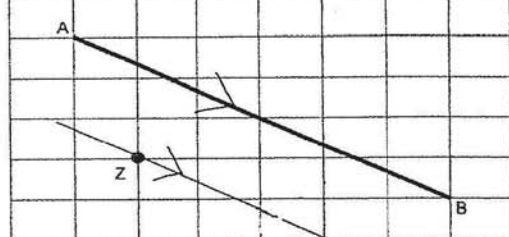
Q27	
Q28	
Q29	<p> $B : C : S \rightarrow 2u + 10 : 2u + 1u + 5$ $5u + 15 \rightarrow \\$120$ $1u \rightarrow (\\$120 - \\$15) \div 5 = \\$21$ Cap $\rightarrow \\$21 \times 2 = \\42 T-shirt $\rightarrow \\$21 + \\$5 = \\$26$ Ans : $\\$42 - \\$26 = \\$16$ </p>
Q30	$\frac{3}{8} + \frac{2}{8} = \frac{5}{8}$

PAPER 2

Q1	<table border="1" data-bbox="311 1220 933 1344"> <tr> <td>T</td> <td>800g</td> <td></td> <td></td> <td></td> </tr> <tr> <td>R</td> <td>800g</td> <td>500g</td> <td></td> <td></td> </tr> <tr> <td>S</td> <td>800g</td> <td>500g</td> <td>800g</td> <td>500g</td> </tr> </table> <p> $R \rightarrow 800 + 500 = 1300$ $S \rightarrow 1300 \times 2 = 2600g$ </p>	T	800g				R	800g	500g			S	800g	500g	800g	500g
T	800g															
R	800g	500g														
S	800g	500g	800g	500g												
Q2	<table border="1" data-bbox="311 1422 813 1545"> <tr> <td>T</td> <td>1u</td> <td></td> <td></td> </tr> <tr> <td>K</td> <td>1u</td> <td>12</td> <td></td> </tr> <tr> <td>R</td> <td>1u</td> <td>12</td> <td>20</td> </tr> </table> <p> $12 + 12 + 20 = 44$ $3u \rightarrow 284 - 44 = 240$ $1u \rightarrow 240 \div 3 = 80$ $R \rightarrow 80 + 12 + 20 = 112$ </p>	T	1u			K	1u	12		R	1u	12	20			
T	1u															
K	1u	12														
R	1u	12	20													
Q3	<p> Total $\rightarrow 4\frac{5}{7}kg$ Bake $\rightarrow \frac{2}{11} \times 4\frac{5}{7} = \frac{6}{7}kg$ Charity $\rightarrow \frac{1}{2}kg$ Left $\rightarrow 4\frac{5}{7} - \frac{6}{7} - \frac{1}{2} = 3\frac{5}{14}kg$ </p>															
Q4	<p>Volume $\rightarrow 9 \times 9 \times 15 = 1215cm^3$</p>															
Q5	<p> a) True b) False </p>															

Q6	<table border="1" style="margin-left: 20px;"> <tr> <td>A</td><td></td><td></td><td></td><td></td><td></td><td></td><td></td><td></td><td></td><td></td><td></td><td></td><td></td><td></td> </tr> <tr> <td>C</td><td>g</td><td>b</td><td>b</td><td>b</td><td>b</td><td></td><td></td><td></td><td></td><td></td><td></td><td></td><td></td><td></td> </tr> </table> <p> $6u \rightarrow 240$ $1u \rightarrow 40$ $15u \rightarrow 600$ </p>	A															C	g	b	b	b	b									
A																															
C	g	b	b	b	b																										
Q7	$\left(\frac{1}{2} \times 4 \times 10\right) + \left(\frac{1}{2} \times 2 \times 10\right)$ $= 20 + 10$ $= 30\text{cm}^2$																														
Q8	<div style="text-align: center;"> <p>Top view</p> </div> <div style="display: flex; justify-content: space-around; margin-top: 20px;"> <div style="text-align: center;"> <p>Front view</p> </div> <div style="text-align: center;"> <p>Side view</p> </div> </div>																														
Q9	<table border="1" style="margin-left: 20px;"> <thead> <tr> <th>C</th><th>R</th><th>D</th><th>Total</th></tr> </thead> <tbody> <tr> <td>6u</td><td>5u</td><td>13u</td><td>24u</td></tr> </tbody> </table> <p> Diff $\rightarrow 13u - 11u = 2u$ $2u \rightarrow 32$ $1u \rightarrow 16$ $24u \rightarrow 16 \times 24 = 384$ </p>	C	R	D	Total	6u	5u	13u	24u																						
C	R	D	Total																												
6u	5u	13u	24u																												
Q10	<p> Watch : Shirt : Left $\rightarrow 8 : 2 : 5$ $8u \rightarrow \\$200$ $1u \rightarrow \\$25$ $15u \rightarrow \\$25 \times 15 = \\375 </p>																														
Q11	<table border="1" style="margin-left: 20px;"> <tbody> <tr> <td>A</td><td>1u</td><td>1u</td><td>1u</td></tr> <tr> <td>B</td><td>1u</td><td></td><td></td></tr> <tr> <td>C</td><td>1u</td><td>60</td><td></td></tr> </tbody> </table> <p> $0 - \\$60 = \\310 $\rightarrow 310$ $1u \rightarrow 310 \div 5 = 62$ Ans(a) : B at first $\rightarrow 62 - 48 = 14$ Ans(b) C $\rightarrow 62 + 60 = 122$ </p>	A	1u	1u	1u	B	1u			C	1u	60																			
A	1u	1u	1u																												
B	1u																														
C	1u	60																													
Q12	<p> a) R : H : L : B $\rightarrow 3u : 1u : 8u : 8u - 60$ $20u - 60 = 300$ $20u \rightarrow 300 + 60 = 360$ $1u \rightarrow 360 \div 20 = 18$ b) Benny $\rightarrow 8 \times 18 - 60 = 84$ Ricky $\rightarrow 3 \times 18 = 54$ Diff $\rightarrow 84 - 54 = 30$ </p>																														

Q13	<p>6 pies \rightarrow $\\$2 \times 2 = \\4 6 puffs \rightarrow $\\$3 \times 3 = \\9 1 sets \rightarrow $\\$4 + \\$9 = \\$13$ Total sets \rightarrow $\\$26 \div \\$13 = 2$ 2 sets \rightarrow 2×6 pies = 12 pies</p>
Q14	<p>DE \rightarrow 16cm Breath \rightarrow $16 \div 2 = 8$cm Whole rectangle area \rightarrow $(16 + 8) \times 8 = 192\text{cm}^2$ Folded part \rightarrow $(\frac{1}{2} \times 4 \times 4) + (\frac{1}{2} \times 16 \times 4) = 8 + 32 = 40$ Shaded part \rightarrow $192 - 40 = 152\text{cm}^2$</p>
Q15	<p>$2N = 5F$ $6N + 7F = \\$74.80$ $15F + 7F = \\$74.80$ $1F = \\$74.80 \div 22 = \\3.40 $2N = \\$3.40 \times 5 = \\17.00 $1N = \\$8.50$ $1N + 1F = \\$8.50 + \\$3.40 = \\$11.90$</p>
Q16	<p>a) $M : K = 2 : 1$ $\\$192 \div 3 = \\64 $M \rightarrow \\$64 \times 2 = \\128 b) $\\$64 - \\$40 = \\$24$ $\\$24 \div 2 = \\12</p>
Q17	<p>a) $W : M \rightarrow 7 : 11$ $7u \rightarrow 28$ $1u \rightarrow 28 \div 7 = 4$ $11u \rightarrow 4 \times 11 = 44$ $40W \rightarrow 28 \times 40 = 1120$ TOTAL \rightarrow $1120 + 44 = \\$1164$ b) $\\$1164 \div 3 = \\388 PRIZES \rightarrow $\\$388 - \\$95 - \\$43 = \\250</p>

4
END