

Anglo-Chinese School (Junior)



BITE-SIZED ASSESSMENT 3 (2024)

PRIMARY 5

SCIENCE

Monday

12 August 2024

45 min

Name: _____ () Class: 5.() Parent's Signature: _____

INSTRUCTIONS TO PUPILS

- 1 Do not turn over the pages until you are told to do so.
- 2 Follow all instructions carefully.
- 3 There are 9 questions in this booklet.
- 4 Answer ALL questions.
- 5 The marks are given in the brackets [] at the end of each question or part question.

Question Paper	Possible Marks	Marks Obtained
Total	25	

This question paper consists of 10 printed pages (inclusive of cover page):

Answer questions 1 to 9. The number of marks available is shown in the brackets [] at the end of each question. (25 marks)

1. The diagram shows a flower.

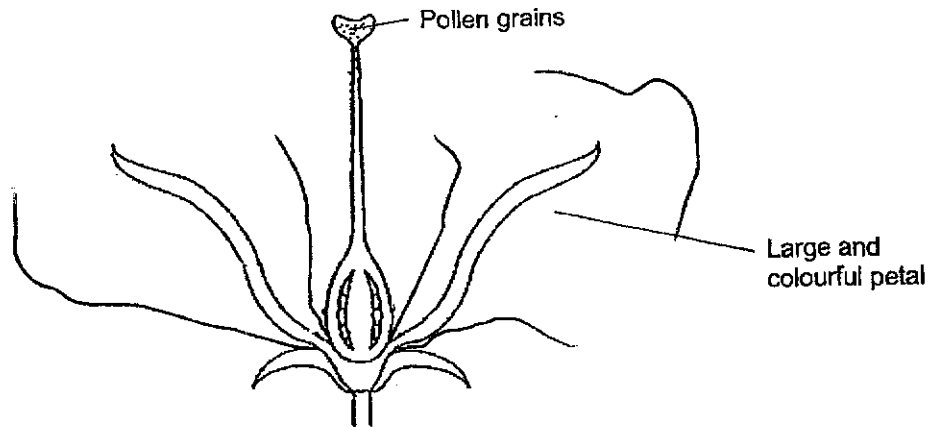

(a) State the function of its large and colourful petals. [1]

(b) Some pollen grains from a similar flower were dusted over the flower shown above. Can the flower develop into a fruit? Explain. [2]

(Go on to the next page)

SCORE	3
-------	---

2. The diagram shows parts of a river where two types of plants (● and △) are growing.

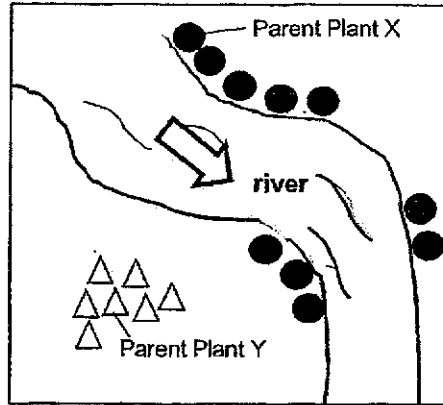

Legend	Plant
●	X
△	Y

(a) How are the fruits or seeds of each plant most likely dispersed? [1]

(i) X: _____

(ii) Y: _____



(b) Give a reason for your answer to (a)(ii). [1]

(c) Name a characteristic of the fruit of plant X. [1]

(Go on to the next page)

SCORE	/
	3

3. The diagram shows the physical characteristics of dog A and dog B.

Dog A		Dog B	
	<ul style="list-style-type: none"> • Fierce towards humans • Blue eyes • White hair with black patches 		<ul style="list-style-type: none"> • Calm towards humans • Green eyes • White hair

The diagram shows dog C, the young of dogs A and B.

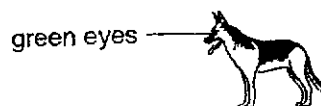

(a) What observable characteristics were passed on to dog C? [1]

(b) Dog C was fierce towards humans. Explain why dog C behave differently from dog B. [1]

(Go on to the next page)

SCORE	2
-------	---

4 The diagrams show the male and female reproductive systems.

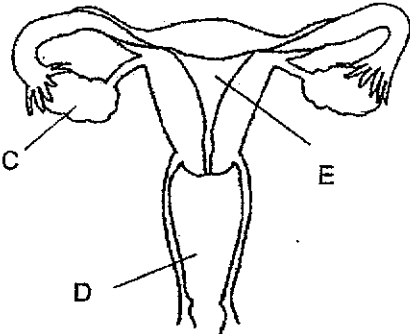
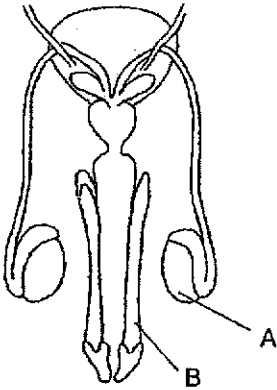

(a) Name parts A to D [2]

A: _____

C: _____

B: _____

D: _____

(b) State the similarity between Part A and Part C. [1]

(c) State the function of part E. [1]

(Go on to the next page)

SCORE	
	4

5. Benjamin set up two electrical circuits, Y and Z, with different bulb arrangements. He added a battery to each circuit and recorded the brightness of the bulbs in a graph as shown.

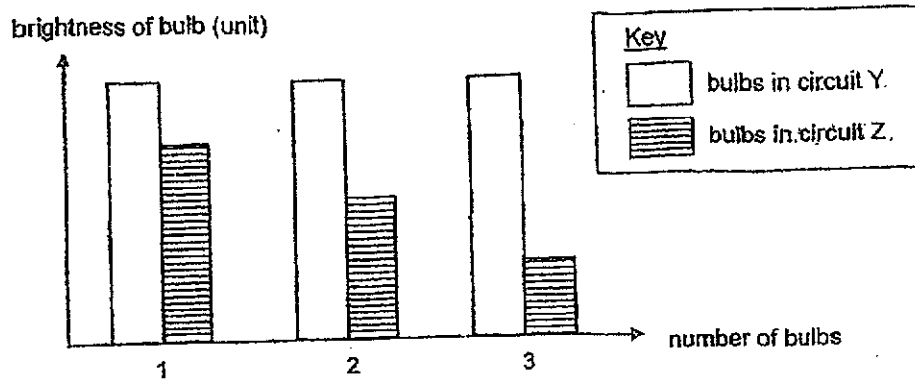

- (a) Based on the graph, state the arrangement of bulbs for circuit Z. [1]

- (b) What can Benjamin do to increase the brightness of the bulbs in circuit Y? [1]

(Go on to the next page)

SCORE	/
	2

6. Nathan wanted the bulb on his toy train to light up when it moves through a tunnel. When both flexible wires on the train touched material Z on the inner roof of the tunnel, the bulb lights up.

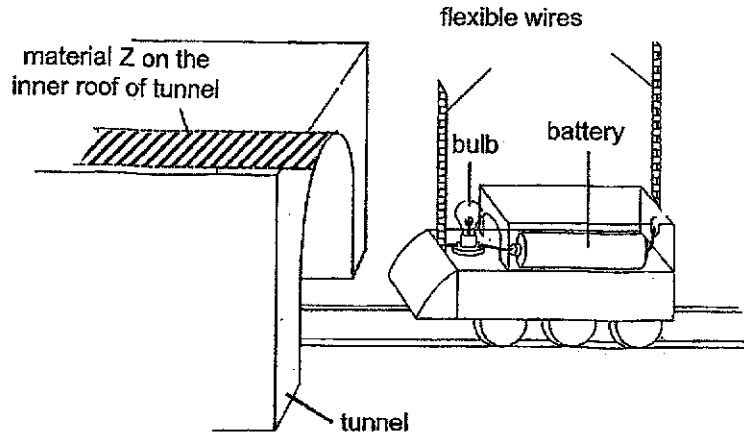

- (a) Explain why the bulb lit up when the train was in the tunnel. [2]

- (b) After playing with the toy train for some time, the bulb glowed brightly and then it did not light up anymore. Suggest a possible reason for this. [1]

(Go on to the next page)

SCORE	3
-------	---

7. James installed a door lock as shown. When he closed the switch, the iron bolt moved to the right, away from the catch and the door was unlocked.

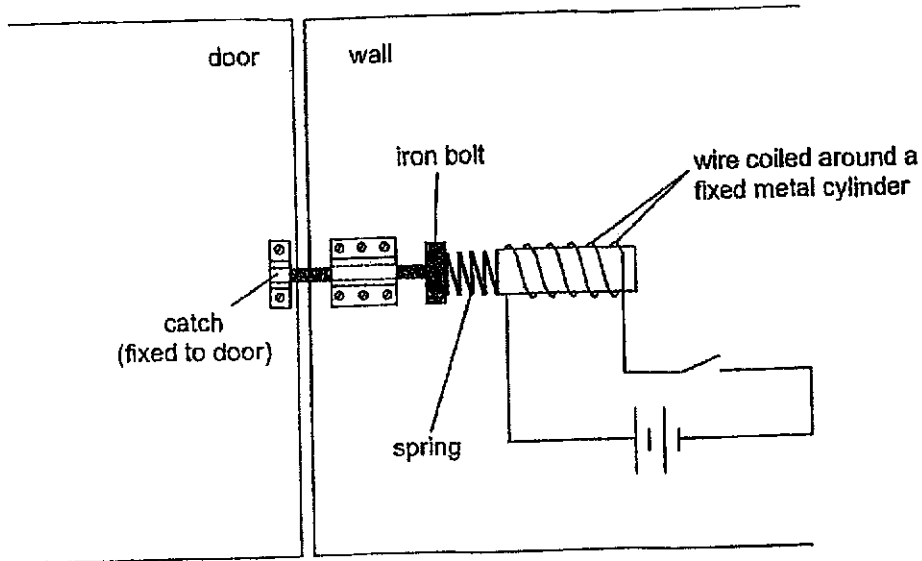

- (a) Explain how the door was unlocked when he closed the switch.

[2]

- (b) State why copper, a type of metal, is used to make wires.

[1]

(Go on to the next page)

SCORE	
	3

8. Diagram 1 shows the front view of Timothy's toy police car. He sets up an electric circuit in the toy using Bulb P, a sound box S and batteries as shown in Diagram 2. All the circuit components are working.

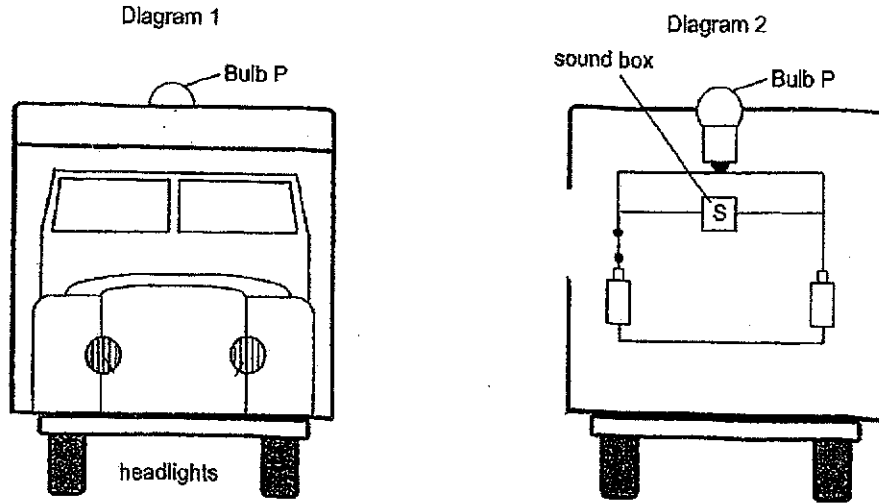

When he closes the switch, the bulb does not light up and there is no sound.

- (a) Draw a circuit below to correct the mistake(s).

[2]

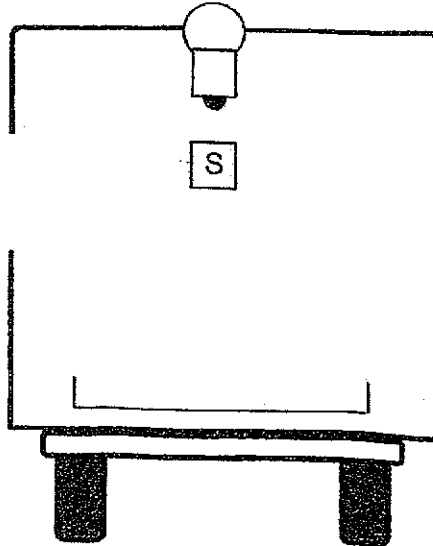

Timothy adds two other light bulbs for the headlights of the toy. When he closes the switch, all three bulbs will light up without dimming bulb P.

- (b) Draw on your circuit in (a) to show how you would connect the two bulbs.

[1]

(Go on to the next page)

SCORE	3
-------	---

9. Read and follow the step-by-step instructions carefully.

Steps:

- 1) Your teacher will give you a bag with two objects, grey and multi-coloured.
- 2) Use the objects and your electricity kit to answer parts (a) and (b)
- 3) Using the components in your electricity kit, test that your bulb and battery are in working condition.

(a) Test which object(s), grey and/or multi-coloured is/are electrical conductors and tick (✓) the correct box(es). [1]

Object	Tick (✓) conductor of electricity
grey	
multi-coloured	

(b) Complete the circuit diagram in the box, showing how you tested the grey object. [1]

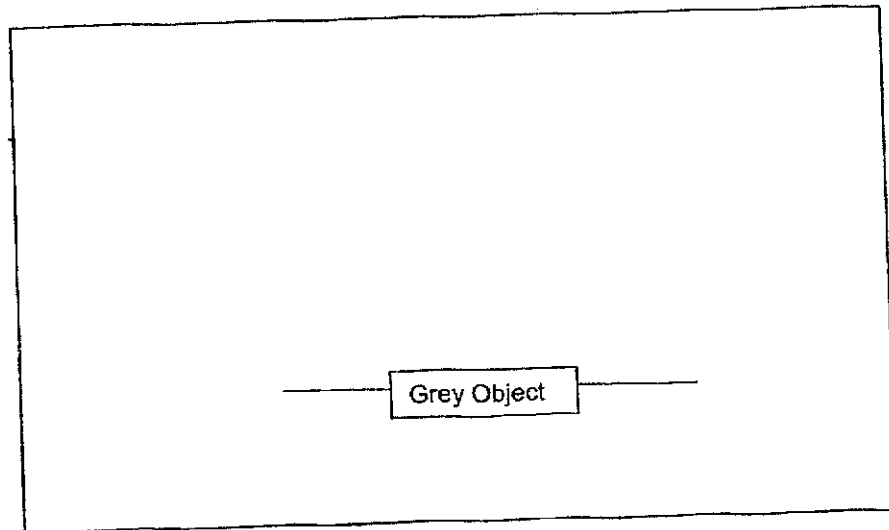

End of Paper

SCORE	2
-------	---

SCHOOL : ANGLO-CHINESE SCHOOL (JUNIOR)
 LEVEL : PRIMARY 5
 SUBJECT : SCIENCE
 TERM : WA3

Q1 (a)	It is to attract pollinators to pollinate the flower.
Q1 (b)	Yes. The female reproductive parts of the flower are present, hence fertilisation can occur for the flower to develop into a fruit.
Q2 (a)	(i) X: Water (ii) Y: Splitting
Q2 (b)	Plant Y disperses its seeds using splitting as they are near each other.
Q2 (c)	Fruit of plant X has a fibrous husk.
Q3 (a)	White hair with black patches and green eyes.
Q3 (b)	Dog A passed its fierce behaviour to dog C.
Q4 (a)	A: Testes B: Penis C: Ovary D: Vagina
Q4 (b)	Both part A and part C contain sex cells.
Q4 (c)	Part E is where the fertilised egg develops.
Q5 (a)	Circuit Z bulb arrangement is by series.
Q5 (b)	Add another battery in circuit Y.
Q6 (a)	Material Z is a conductor of electricity. The metal strips will form a closed circuit when in contact with material Z, hence allowing electricity to pass through the circuit.
Q6 (b)	The bulb fused.

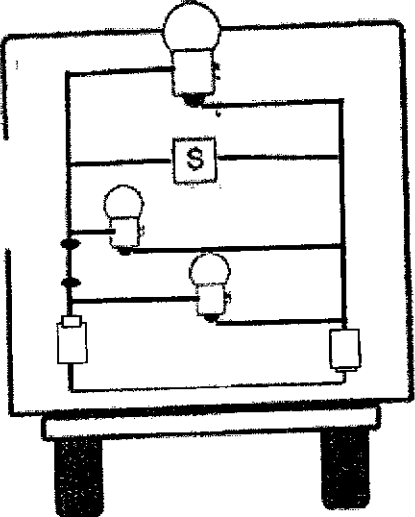
Q7 (a)	When the switch is closed, the metal cylinder becomes magnetised and attracts the iron bolt.
Q7 (b)	Copper is a conductor of electricity.
Q8 (a) (b)	
Q9 (a)	grey
Q9 (b)	