



**NANYANG PRIMARY SCHOOL**

**PRIMARY 5 SCIENCE**

**SEMESTRAL ASSESSMENT 2  
2012**

**BOOKLET A**

**Date : 11 October 2012  
Duration : 1 h 45 min**

**Name : \_\_\_\_\_ (     )**

**Class: Primary 5 (     )**

**Parent's signature: \_\_\_\_\_**

**DO NOT OPEN THIS BOOKLET UNTIL YOU ARE TOLD TO DO SO.  
FOLLOW ALL INSTRUCTIONS CAREFULLY.**

**Booklet A consists of 24 printed pages including this cover page.**

**Section A (30 x 2 marks = 60 marks)**

For each question from 1 to 30, four options are given. One of them is the correct answer. Make your choice (1, 2, 3 or 4). Shade the correct oval (1, 2, 3 or 4) on the Optical Answer Sheet provided.

1. The table below states some of the physical factors in planets A, B, C and D.

Planet	Composition of air	Temperature (°C)	Presence of water
A	68% nitrogen 31% oxygen 1% carbon dioxide and other gases	78	Yes
B	78% nitrogen 21% oxygen 1% carbon dioxide and other gases	28	Yes
C	78% nitrogen 22% oxygen 1% carbon dioxide and other gases	38	No
D	78% nitrogen 11% oxygen 1% carbon dioxide and other gases	8	No

Only Planet B is observed to support life. Based on the information in the table above, which of the following statements are possible explanations for the observation?

- A There is sufficient warmth to support living things.
- B There is sufficient oxygen to allow living things to respire.
- C There is presence of water to ensure survival of living things.
- D There is presence of carbon dioxide to allow plants to make food.

- (1) A, B and C only
- (3) B, C and D only

- (2) A, C and D only
- (4) A, B, C and D

2. Patrick wanted to find out how the change in the distance,  $x$ , between the tip of the straw at his mouth and the ball that was placed on a wooden block would affect the distance travelled by a cone that was hit by the ball. He took a deep breath and blew through a straw. He kept the following variables constant as he repeated the experiment a few times.

The variables that were kept constant.

- the height at which the ball was placed on the wooden block
- surface of the plank
- type of ball
- type of cone

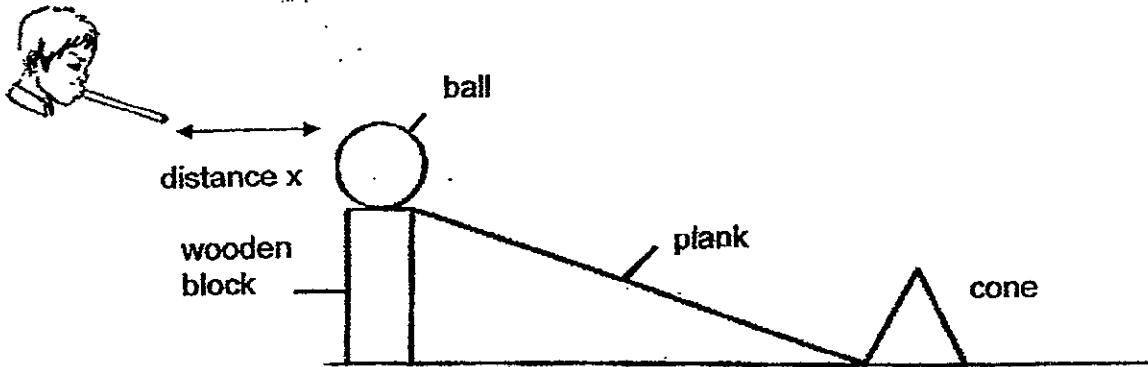

Based on the experiment above, which of the following correctly identified the other variable(s) that must be kept constant and the variable(s) that should be changed to ensure a fair test?

	Variable(s) changed	Variables kept constant
(1)	force of each blow length of straw	length of plank distance $x$
(2)	force of each blow	length of plank distance $x$ length of straw
(3)	distance $x$	length of plank length of straw force of each blow
(4)	force of each blow length of straw	distance $x$ length of straw

3. Which one of the following diagrams correctly represents the exchange gases between living organisms and their surroundings during the processes of respiration and photosynthesis?

(1)

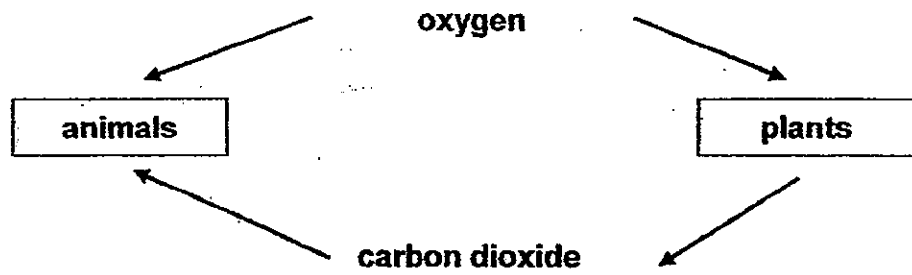

(2)

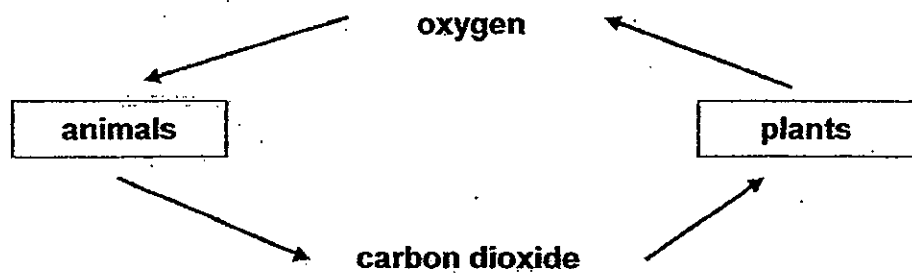

(3)

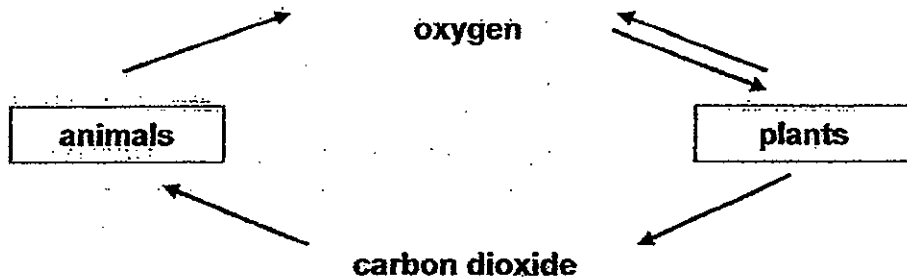

(4)

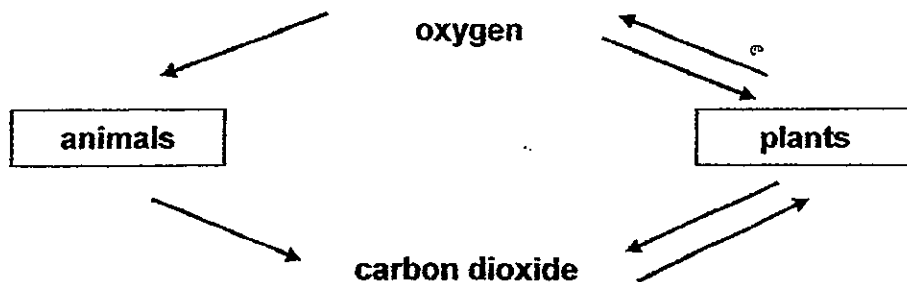

4. Sarah placed a leaf into a beaker of hot water as shown in the diagram below.

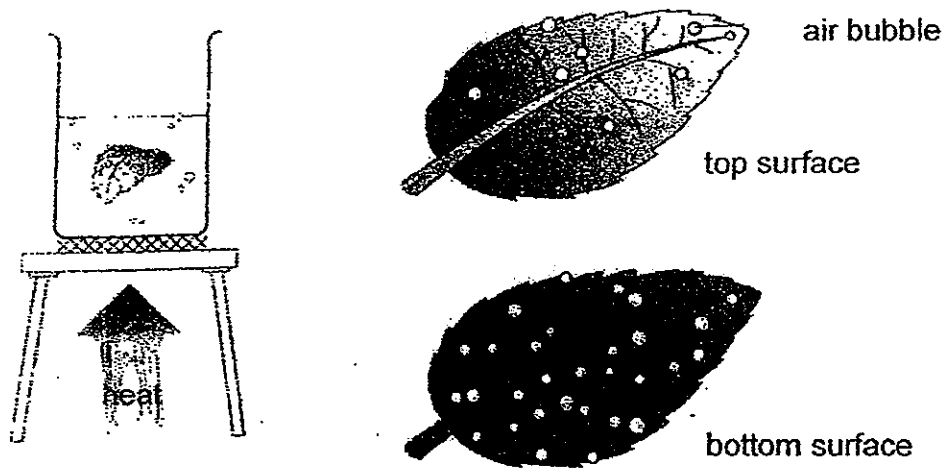

She observed that small bubbles of air appeared almost immediately and started to escape from both the top and bottom surfaces of the leaf. There were also more air bubbles forming on the bottom surface of the leaf compared to the top surface.

Which one of the following statements below best explained her observation?

- (1) Air spaces in the leaf expanded when the leaf was placed into the hot water.
- (2) There were more stomata on the bottom surface of the leaf compared to the top surface.
- (3) A greater amount of air was present in the spaces between the cells on the bottom surface of the leaf than at the top surface.
- (4) The hot water had air dissolved in it and the bottom surface of the leaf can trap a greater number of air bubbles compared to the top surface.

5. The diagram below shows the cells found in the bottom surface of a leaf.

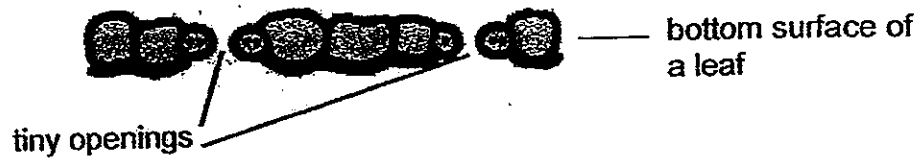

Which of the following correctly describe the functions of the tiny openings found on the bottom surface of the leaf?

- A To trap sunlight for the leaf to make food
- B To allow the leaf to absorb water from the soil
- C To allow water to be released to the surroundings as water vapour
- D To allow the exchange of gases between the leaf and the surroundings

- (1) A and B only
- (3) B and D only

- (2) A and C only
- (4) C and D only

6. John recorded his breathing rate at rest for 5 minutes, before he started to run in a race for 5 minutes. His breathing rate was continuously being measured for the entire 15 minutes.

Which one of the following graphs correctly represents a possible change in his breathing rate before, during and after the race?

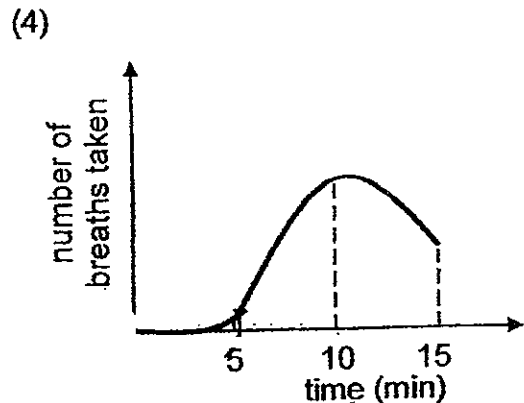
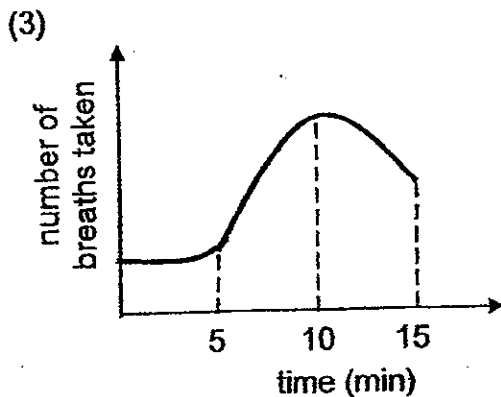
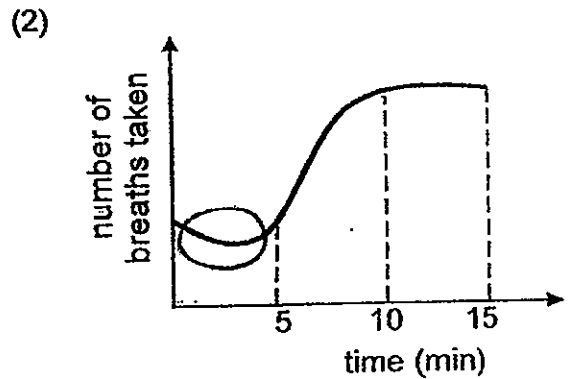
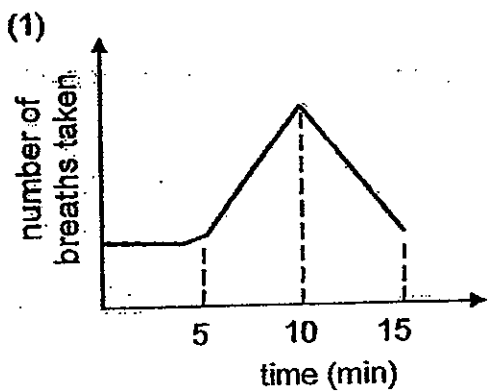

7. The diagram below shows the human respiratory system with the parts labelled A, B and C.

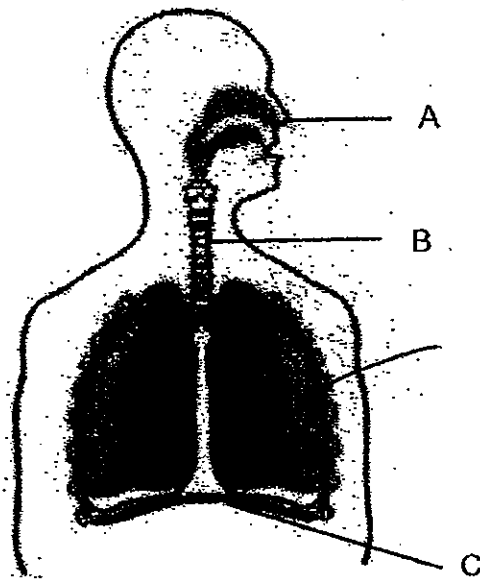

Which one of the following correctly states the functions of parts A, B and C of the respiratory system during breathing?

	A	B	C
(1)	controls the types of gases that enter the lungs	produces mucus to trap dirt in the air	prevents the ribcage from collapsing
(2)	enables us to detect smell	relaxes to move air into the lungs	controls the rate of breathing
(3)	filters the air before it enters into the lungs	leads air into the lungs	contracts to allow the lungs to draw in air
(4)	leads air in and out of the respiratory system	connects nose to chest cavity	makes the chest cavity air-tight

8. Elaine used the diagram below to study the structure of the human lungs.

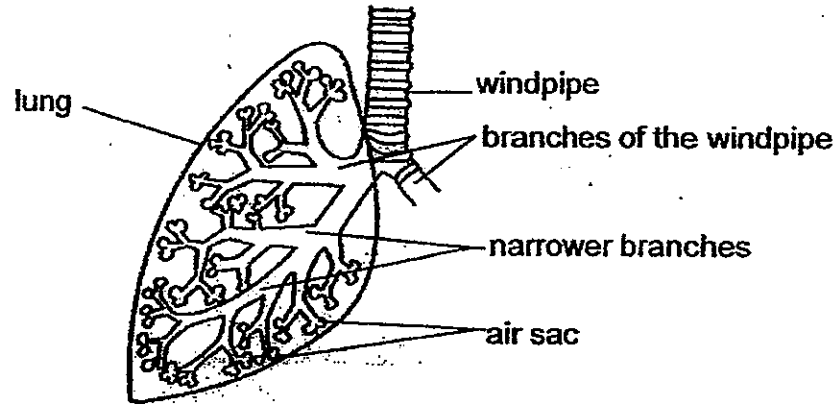

Based on her observations, she made the following statements.

- A The air will pass from the windpipe into the air sac during inhalation
- B The air sacs allow more air to be taken in by the lungs.
- C The air sacs help to increase the surface area for gaseous exchange in the lungs.

Which of her statements are correct?

- (1) A and B only
- (2) A and C only
- (3) B and C only
- (4) A, B and C



9. The model below shows a representation of how the human respiratory system works.

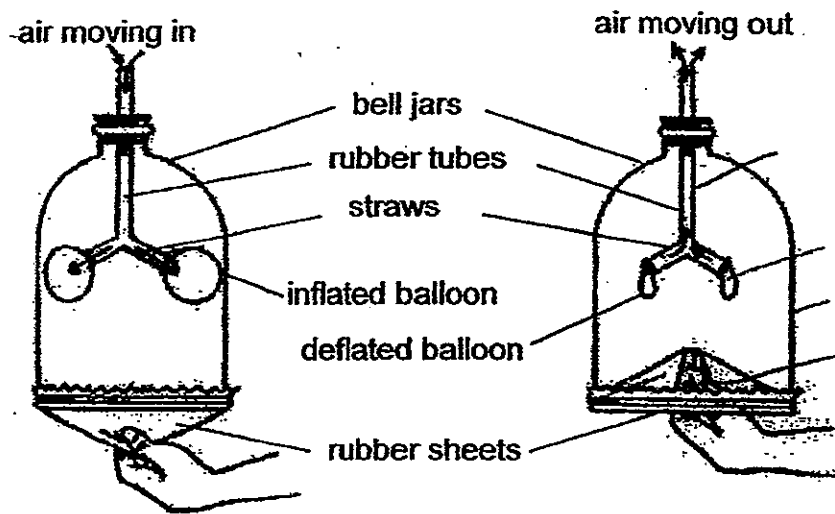

Which parts of the human body are correctly represented by the parts in the model?

	bell jar	rubber tube	balloon	rubber sheet
(1)	diaphragm	windpipe	lung	ribcage
(2)	ribcage	windpipe	lung	diaphragm
(3)	ribcage	diaphragm	windpipe	lung
(4)	windpipe	lung	ribcage	diaphragm

10. Which of the following statements about the human circulatory system are correct?

- A Oxygen-poor blood is returned to the heart before it reaches the lungs.
- B Oxygen-poor blood is returned directly to the lungs without reaching the heart first.
- C Contraction and relaxation of the muscles in the lungs help to move the blood around the body.
- D Contraction and relaxation of the muscles in the heart help to move the blood around the body.

- (1) A and D only
- (2) C and D only
- (3) A, B and D only
- (4) A, B, C and D

11. Marianne's teacher told her to check and count her pulse rate for a minute after engaging in 3 different physical activities. She repeated each activity thrice and recorded her results in the table as shown below.

Activities	Pulse rate per minute		
	1 <sup>st</sup> try	2 <sup>nd</sup> try	3 <sup>rd</sup> try
reading	68	69	70
walking	80	81	82
jogging	100	101	102

Which one of the following correctly identifies the aim and conclusion for the above experiment?

	Aim of experiment	Conclusion
(1)	To find out how her pulse rate is affected by different physical activities.	When the physical activity is more vigorous, her pulse rate increases.
(2)	To find out how her breathing increases after doing a physical activity.	Her rate of breathing is the lowest when she is reading.
(3)	To find out how fast her heart pumps after each physical activity.	Her heart beats the fastest when she is jogging.
(4)	To find out how her rate of breathing changes with different activities.	Her rate of breathing is affected by the different activities.

12. Which of the following substances are transported by the blood?

- A oxygen
- B cell sap
- C digested food
- D carbon dioxide

- (1) C and D only
- (2) A, C and D only
- (3) B, C and D only
- (4) A, B, C and D only

13. The diagram below shows a few air sacs which are surrounded by blood vessels. The blood vessel X carries blood from the heart while the vessel Y carries blood to the heart.

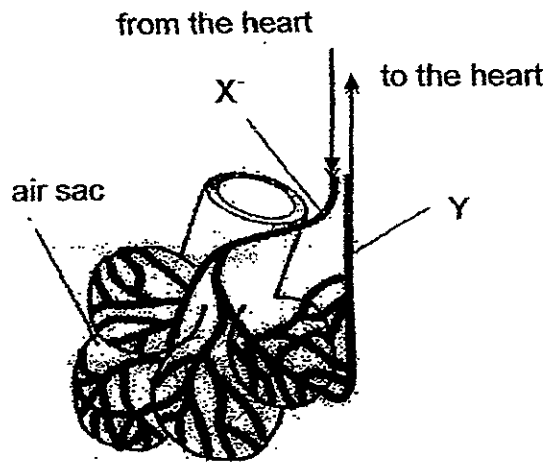

Based on the diagram above, which of the following statements is/ are false?

- A The blood in X is richer in oxygen than blood in Y.
- B The blood in Y is poorer in carbon dioxide than in X.
- C The air leaving the air sac and out of the body does not contain oxygen.
- D The gaseous exchange occurring at the air sac is known as respiration.

- (1) A and B only
- (2) B and C only
- (3) ~~B, C and D only~~ A, C and D
- (4) A, B, C and D

14. The diagram below shows how food and air are transported in the body.

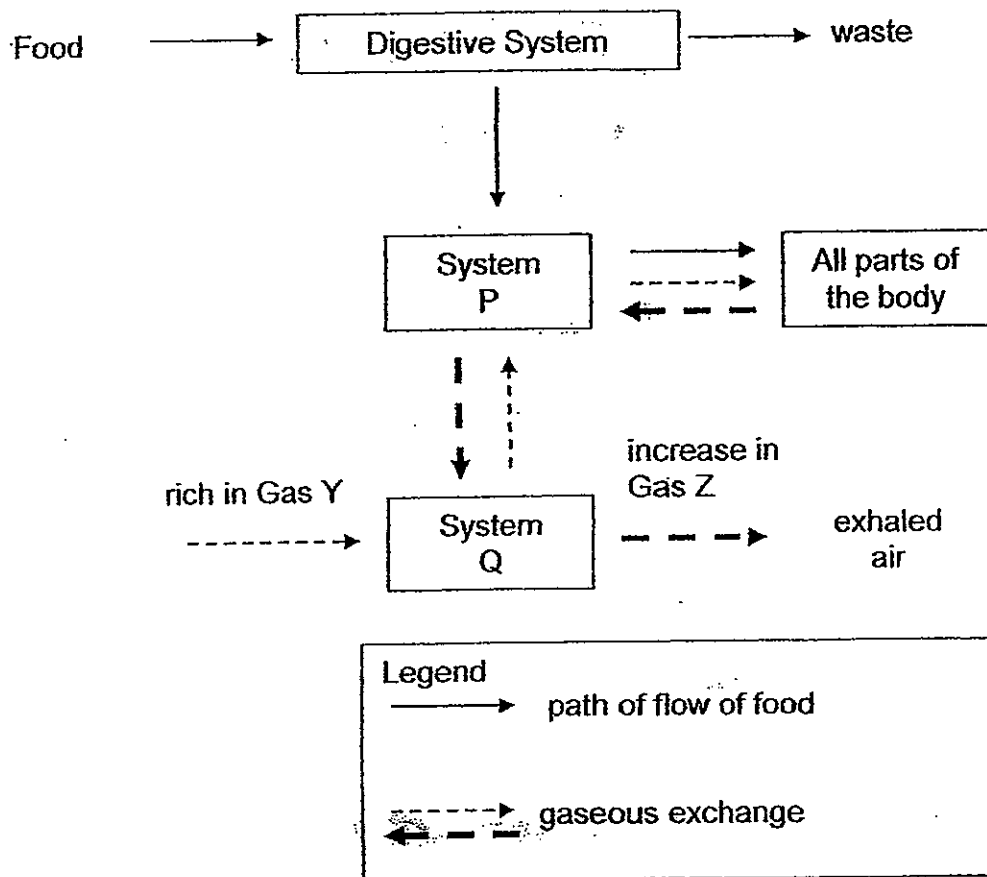

Which one of the following correctly identifies Systems P and Q, and Gases Y and Z?

	System P	System Q	Gas Y	Gas Z
(1)	circulatory system	respiratory system	oxygen	carbon dioxide
(2)	circulatory system	respiratory system	carbon dioxide	oxygen
(3)	respiratory system	circulatory system	oxygen	carbon dioxide
(4)	respiratory system	circulatory system	carbon dioxide	oxygen

15. Alisah and Billy observed the following cell under the microscope.

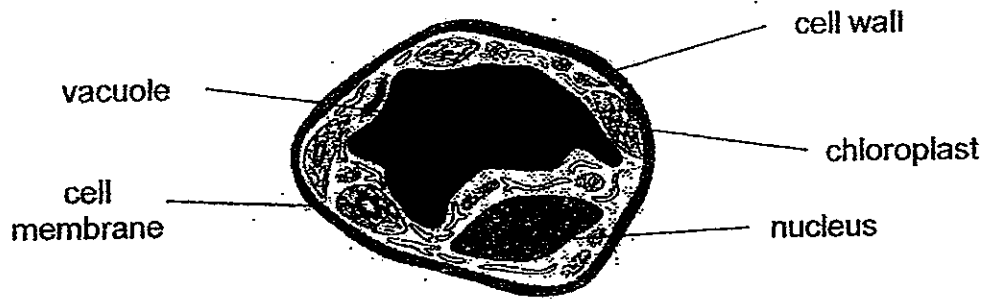

Cell A

Based on their observation, they made the following statements.

- A Cell A is a plant cell as it has a cell wall.
- B Cell A is a plant cell as it has chloroplasts.
- C Cell A is an animal cell as it has a cell membrane.
- D Cell A is an animal cell as it has a large central vacuole.

Which of the statement(s) is/are **correct**?

- (1) A and B only
- (2) A and C only
- (3) B and C only
- (4) B and D only

16. Which one of the following cells contains chloroplasts?

- (1) Cell from the stalk of celery
- (2) Cell from a ginger root
- (3) Cell from an apple fruit
- (4) Cell from a carrot root

17. Four pupils, A, B, C and D, examined the following types of cells under a microscope.

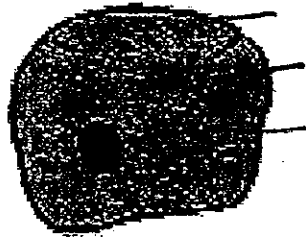

Cell X

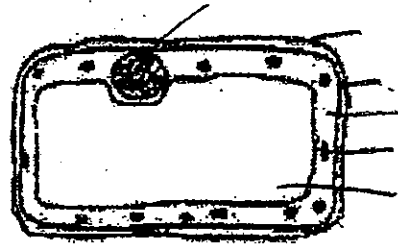

Cell Y

They recorded their observations in a table as shown below.  
A tick (✓) indicated the presence of the cell part.

Pupil	Cell	Cell Wall	Cytoplasm	Cell membrane	Chloroplast
A	X		✓		✓
B	Y	✓		✓	✓
C	X		✓	✓	
D	Y	✓	✓	✓	✓

Which pupil(s) had made the **correct** observations?

- (1) A and B only  
 (2) C and D only  
 (3) A, B and D only  
 (4) A, B, C and D

18. The head of a sperm helps it to pass through the outer layers of an ovum. Some males may produce abnormal sperms with smaller heads or absent tail-like structures as shown in the diagrams below. This can prevent fertilisation from taking place.

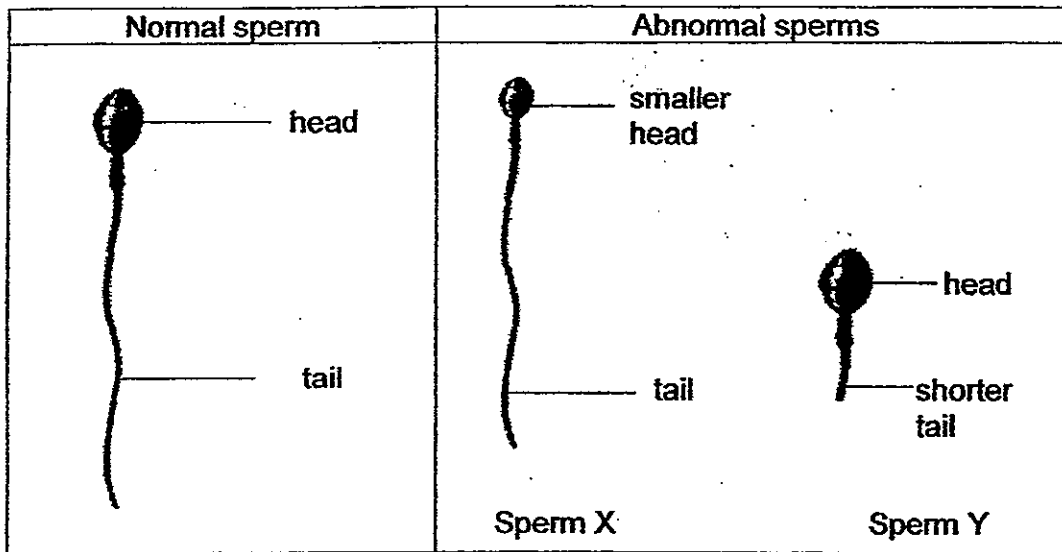

Based on the information above, which of the following clearly explains the reason for the unsuccessful fertilisation between the deformed sperm and the ovum?  
*adnormal*

- A Sperm Y is less able to pass through the ovum to fuse with the nucleus.
  - B Sperm Y is less able to swim towards the ovum.
  - C Sperm X is less able to pass through the outer layers of the ovum to fuse with the nucleus.
  - D Sperm X swims too fast as its size is smaller and hence misses the ovum.
- (1) A and B only
  - (2) B and C only
  - (3) A, C and D only
  - (4) A, B, C and D

19. Sally removed the outer part of the stem of a plant as shown below. A week later, she observed that part X of the plant had swollen up. She then cut the stem at the part as indicated by the dotted line.

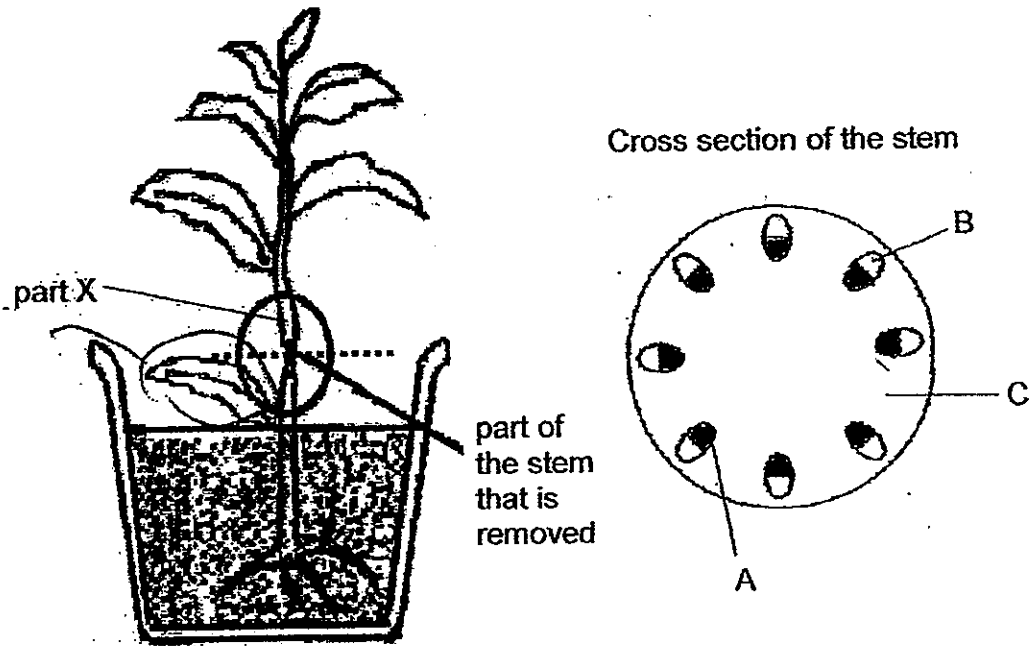

If the plant remained alive after a week, which part(s) of the plant had Sally removed?

- |                  |                |
|------------------|----------------|
| (1) A only       | (2) B only     |
| (3) A and B only | (4) A, B and C |



20. Jason set-up three identical containers, D, E and F, with the same amount of water and a layer of oil. He placed two similar plants in containers E and F only. All 3 containers were left on a table. The water levels of the containers in all the set-ups were recorded after 5 hours.

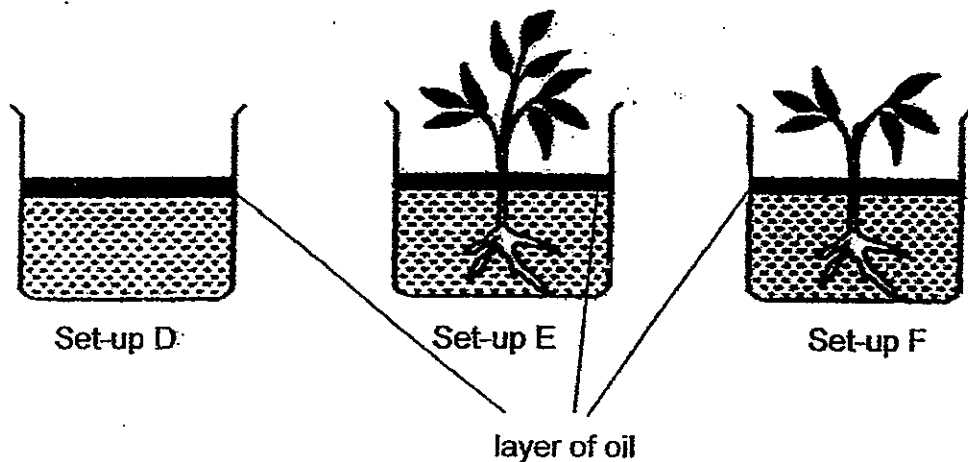

Which one of the graphs below represents the water level in the 3 set-ups after 5 hours?

(1)

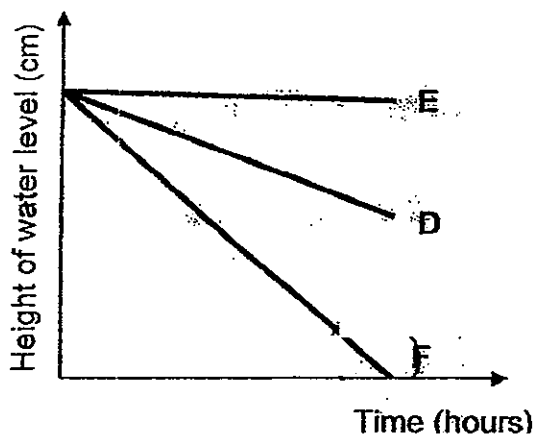

(2)

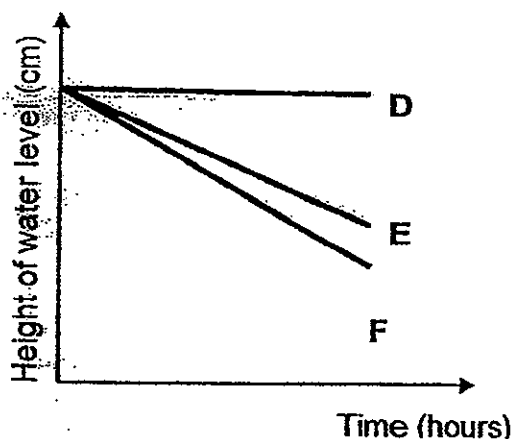

(3)

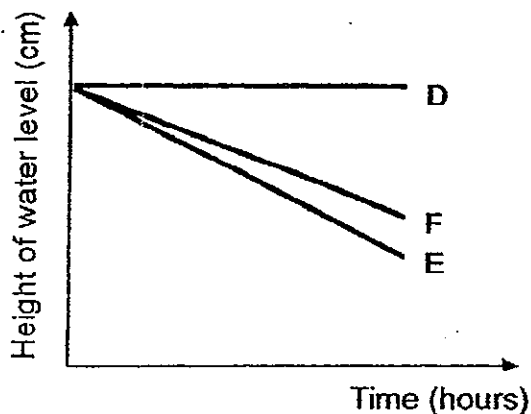

(4)

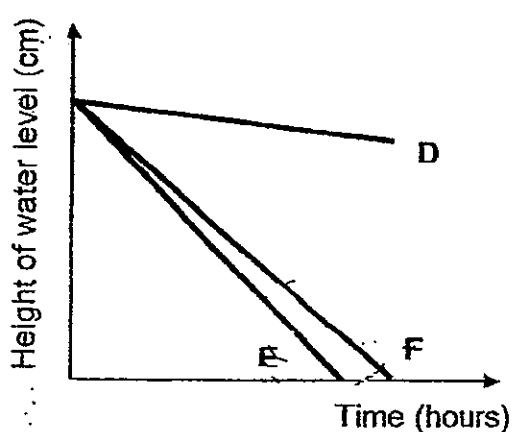

21. Some water containing red dye was poured into the soil of a potted plant. After 3 hours, some parts of the flowers and leaves turned red.

Which of the following statements **correctly explained** the above observation of the potted plant after 3 hours?

- A Water containing the red dye was taken in by the roots and then transported to the leaves and flowers of the plant.
- B Water containing the red dye was carried in the water-carrying tubes in the stem to other parts of the plant.
- C Water containing the red dye was mixed with the food carried in the food-carrying tubes in the stem to other parts of the plant.

- (1) A and B only
- (2) A and C only
- (3) B and C only
- (4) A, B and C

22. In the diagram below, arrows S and T represent the transportation of water and food from one part of a plant to another. Parts G and H represent different parts of the plant.

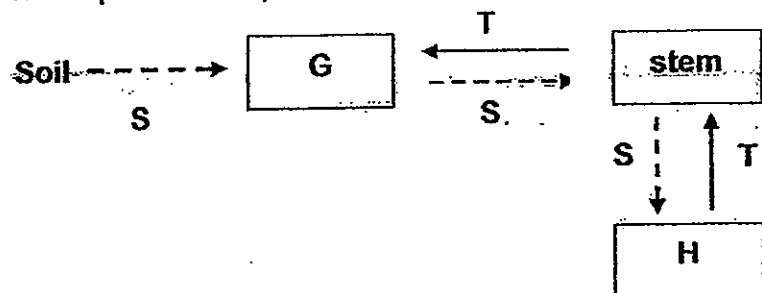

Which one of the following correctly represents G, H, S and T?

	G	H	S	T
(1)	fruits	roots	water	food
(2)	leaves	roots	food	water
(3)	roots	leaves	water	food
(4)	fruits	leaves	food	water

23. Jasmine took two angšana fruits, A and B, of the same size. She trimmed off the wing of fruit B as shown in the diagram below.



Jasmine then dropped the fruits from the same height and recorded the time taken in seconds by each fruit to reach the ground in the table as shown below.

	Time taken for the fruit to reach the ground (in seconds)		
	1 <sup>st</sup> try	2 <sup>nd</sup> try	3 <sup>rd</sup> try
Fruit A	8.9	8.4	8.6
Fruit B	4.2	3.8	3.7

Based on the results recorded in the table, what was the aim of Jasmine's experiment?

- (1) To find out how the presence of the wing-like structures of the angšana fruit affected the time taken for the fruit to reach the ground.
- (2) To find out how the height at which the fruit was dropped affected the time taken for the fruit to reach the ground.
- (3) To find out how the wing-like structures of the angšana fruit kept it afloat in the air.
- (4) To find out how the presence of the wing-like structures of the angšana fruits affected the distance it travelled.

24. The following table gives information on three plants A, B and C, and three characteristics. A tick (✓) shows that the plant had the characteristic.

Characteristic	Plant		
	A	B	C
Grows from spores		✓	
Bears fruits with wing-like structure	✓		
Seeds are <del>in</del> dispersed close to parent plant			✓

Which of the following could represent plants A, B and C?

	A	B	C
(1)	Shorea	Moss	Coconut
(2)	Shorea	Fern	African tulip
(3)	Coconut	Moss	African tulip
(4)	Lalang	Fern	Balsam

25. The following diagrams show the process of germination of a bean.

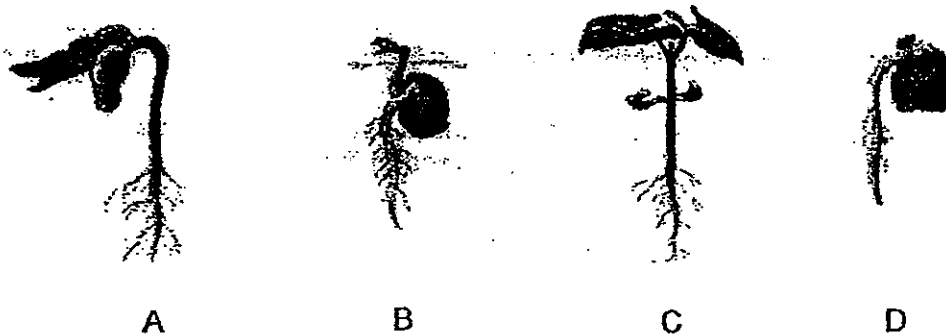

Which of the following correctly represents the order of germination for the beans above?

- (1) A, C, D and C  
 (2) B, D, C and A  
 (3) C, D, A and B  
 (4) D, B, A and C

26. Which one of the following flowers can develop into a fruit after pollination?

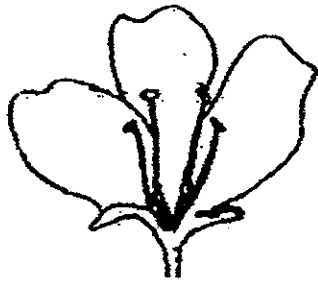

A

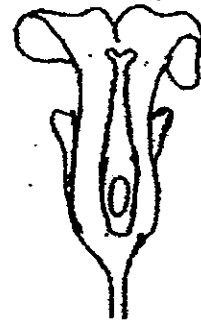

B

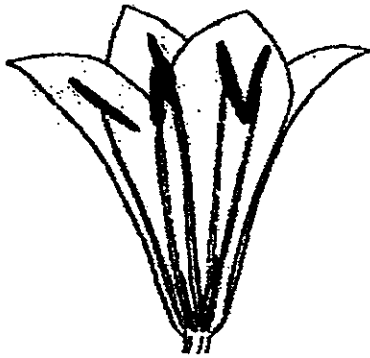

C

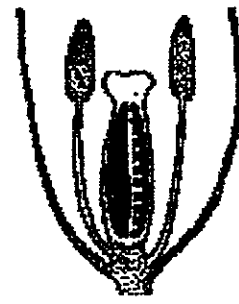

D

- (1) A and B only
- (2) A and D only
- (3) B and C only
- (4) B and D only



27. Five bar magnets with their ends marked A to J can be arranged as shown below.

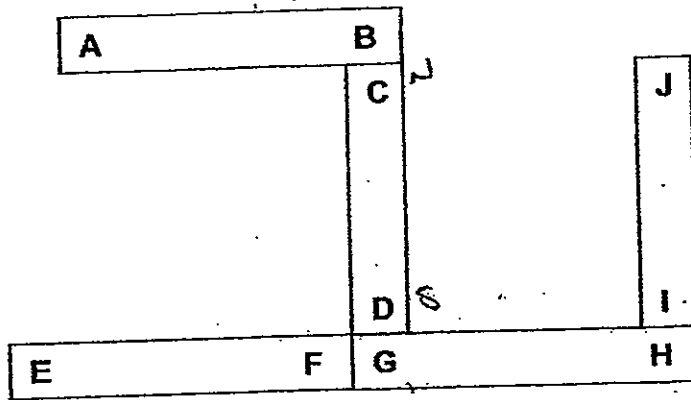

Which one of the following diagrams shows a possible arrangement of two of the magnets?

(1)

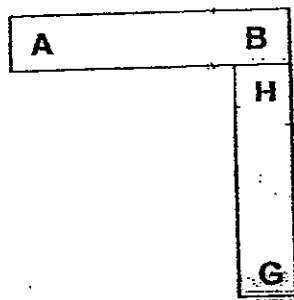

(2)

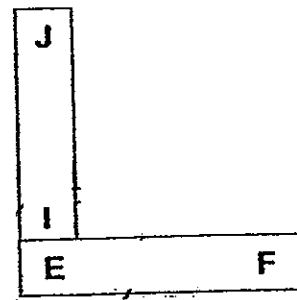

(3)

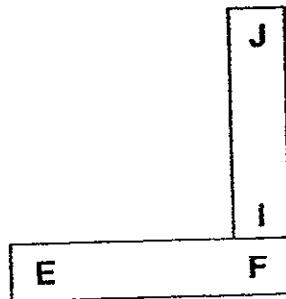

(4)

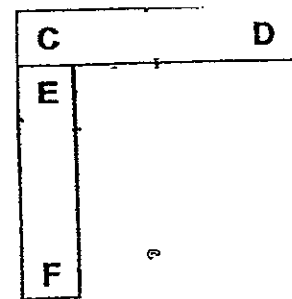





28. Ryan tested four nails made of different magnetic materials, A, B, C and D, by using the electrical set-up shown in the diagram below.

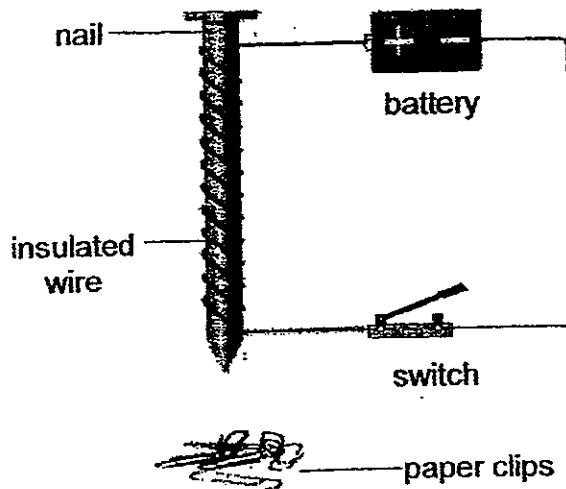

When the switch was closed, the nail picked up some steel paper clips. Ryan counted the number of paper clips that were picked up and recorded the results in the table below.

Nail	A	B	C	D
Number of steel paper clips	12	4	7	21

Based on the results obtained, what could Ryan conclude from the experiment?

- (1) Nail A was the strongest electromagnet.
- (2) Nail B could pick up 4 more steel paper clips if more coils were wound round the nail.
- (3) Nail A would attract the most number of steel paper clips if another battery was added to the set-up.
- (4) Nail C was a weaker electromagnet than Nail D but a stronger electromagnet than Nail B.

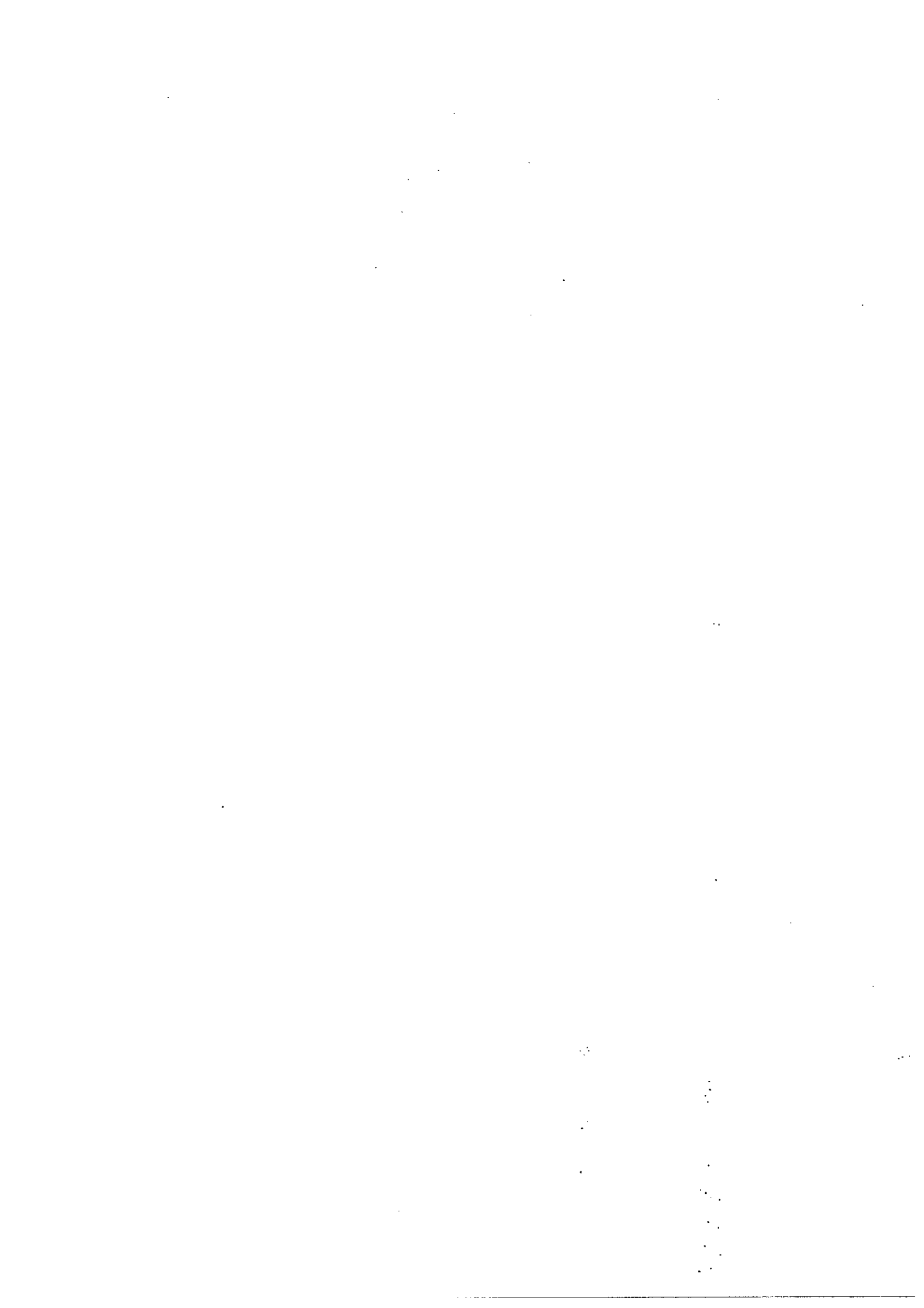

29. Yuki placed two identical ring magnets, A and B, through a wooden rod as shown in the diagram below. She observed that magnets A and B were at a distance, K, from each other.

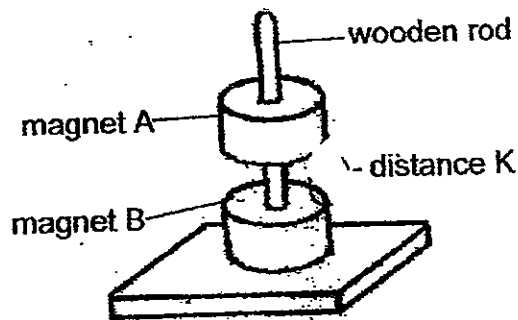

Which of the following actions could decrease distance K?

- A Change the wooden rod to a plastic rod.
- B Flip magnet A over and replace it on the wooden rod.
- C Place a magnetic object between magnet A and magnet B.

- (1) A and B only
- (2) A and C only
- (3) B and C only
- (4) A, B and C

30. Keagan turned an iron bar into a temporary magnet using the stroking method. He then brought the iron bar near three different objects, X, Y and Z. He recorded the results in the table below. A tick (✓) indicates the observations that Keagan had made.

Object	X	Y	Z
Observations			
Attracted to iron bar	✓	✓	
Repels from iron bar	✓		
Not attracted to iron bar			✓

Which of the following statements about X, Y and Z is/are definitely true?

- A Object X is a magnet.
- B Object Y is made of copper.
- C Object Z is made up of a non-magnetic material.

- (1) B only
- (2) C only
- (3) A and C only
- (4) B and C only





**NANYANG PRIMARY SCHOOL**

**PRIMARY 5 SCIENCE**

**SEMESTRAL ASSESSMENT 2  
2012**

**BOOKLET B**

**Date : 11 October 2012**

**Duration : 1 h 45 min**

**Name : \_\_\_\_\_ (     )**

**Class: Primary 5 (     )**

**Marks Scored:**

<b>Booklet A:</b>		<b>60</b>
<b>Booklet B :</b>		<b>40</b>
<b>Total :</b>		<b>100</b>

**Any query on marks awarded should be raised by 25<sup>th</sup> October 2012. We seek your understanding in this matter as any delay in the confirmation of marks will lead to delays in the generation of results.**

**Parent's signature: .....**

**DO NOT OPEN THIS BOOKLET UNTIL YOU ARE TOLD TO DO SO.  
FOLLOW ALL INSTRUCTIONS CAREFULLY.**

**Booklet B consists of 17 printed pages including this cover page.**

**Section B (40 marks)**

Write your answers to questions 31 to 44 in the spaces provided.  
Marks will be deducted for misspelt key words.

31. The table below shows how Benjamin's heart rate changes as he exercises.

Duration of exercise (in minutes)	0	2	4	6	8	10	12
Number of heart beats per minute	64	86	110	130	140	140	140

(a) State the relationship between Benjamin's heart rate and the duration of the exercise. [1]

---

---

---

(b) Give 2 reasons to explain why Benjamin's heart beat is faster when he is exercising than before he starts exercising. [2]

(i)

---

---

(ii)

---

---

(c) Explain how you expect Benjamin's breathing rate to change with respect to his heart rate during exercise. [1]

---

---

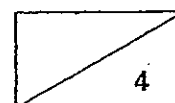

32. Nicholas conducted an experiment where he set up a tank of water containing 1 fish. He fed the fish but did not change the water for a week. He recorded his observation of the fish in the table as shown below.

Number of days	1	2	3	4	5	6	7
Average number of times the gill covers open and close in 30 seconds	6	9	13	17	20	23	28

- (ai) Based on the table above, state the aim of Nicholas' experiment. [1]

---

---

- (a(ii)) Based on your answer in (a), state a possible conclusion of Nicholas' experiment. [1]

---

---

- (b) State a reason why the number of times the gill covers opened and closed changed over time. [1]

---

---

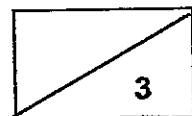

The diagram below shows the circulatory system of the fish in his experiment. Arrow X represents the blood vessel that carries blood which flows directly from the gills of the fish to the other parts of its body. Arrow Y represents the blood vessel that carries blood which flow from the other parts of the body to the heart then back to the gills.

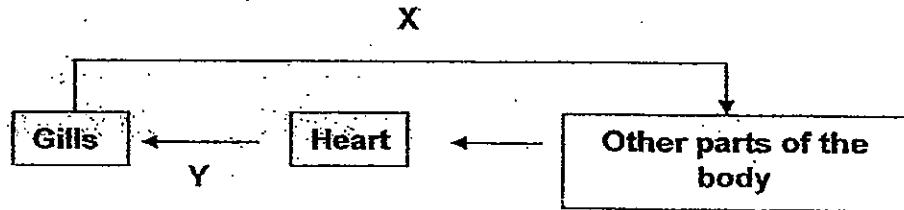

- (c) State one difference between the blood found in blood vessel X and blood vessel Y. [1]

---

---

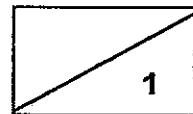



33. The diagrams below show the lungs in the human and the gills in the crab. Both organs help the 2 organisms to breathe.

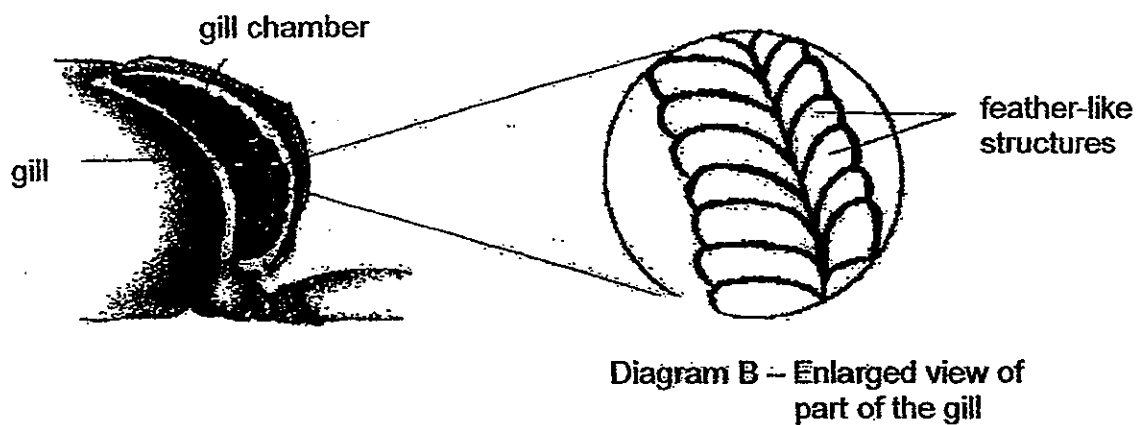
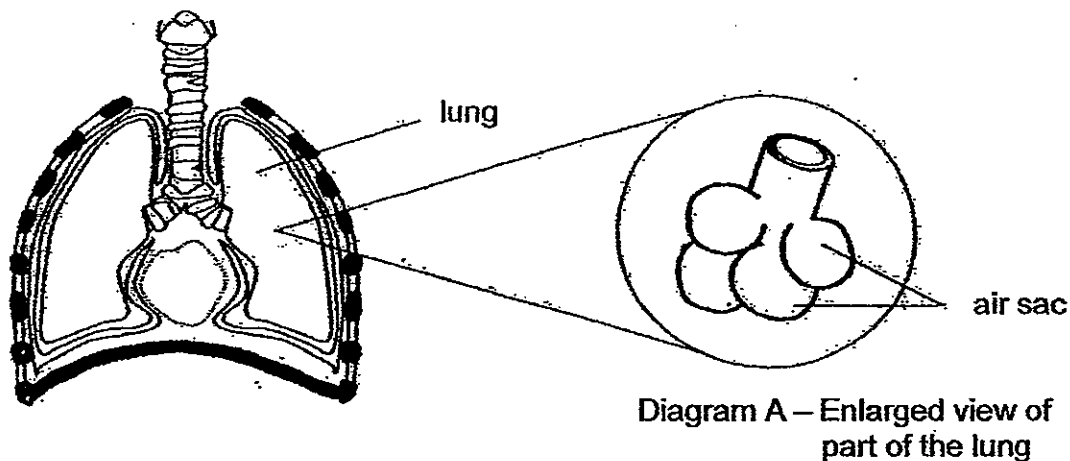

(a) State a difference in the way the lungs and the gills obtain air from the surroundings. [1]

---



---

(b) Describe one similarity in the way the structures in diagrams A and B help to allow gaseous exchange to take place quickly. [1]

---



---

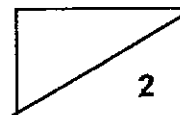

34. The diagram below represents the parts of a plant.

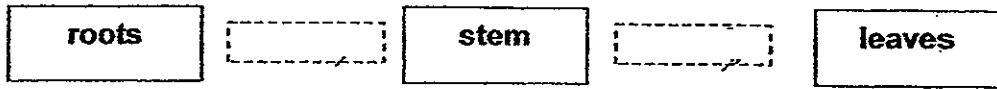

(ai) Draw arrows in the 2 dotted boxes above to represent the movement of water in a plant. [1]

(aii) What happens to the water after it reaches the leaves? [1]

---

---

The arrows below represent the flow of blood in a human body.

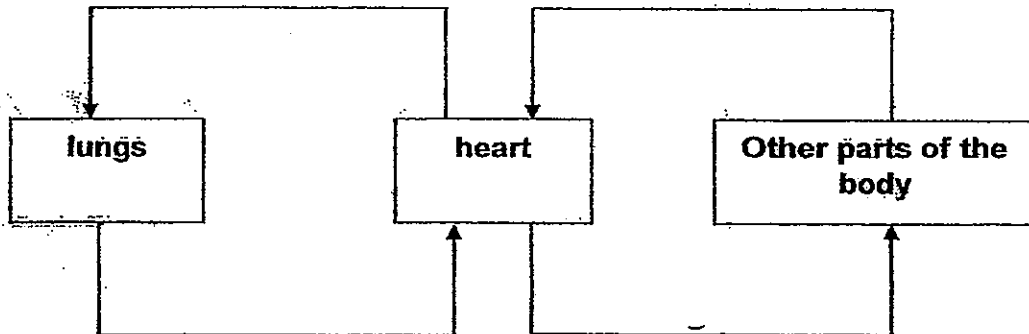

(b) State one difference between the direction of movement of water in plants and the direction of movement of blood in the human body. [1]

---

---

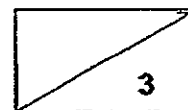

35. Ruth planted some plants. These plants produced insect-pollinated flowers in her garden. Each time these flowers bloomed, she would cut away the petals.



Petals are intact



Petals are removed

(ai) Draw a line on the graph below to show the change in the number of fruits that she would observe over several years if she continued to remove the petals. [1]

Number of fruits

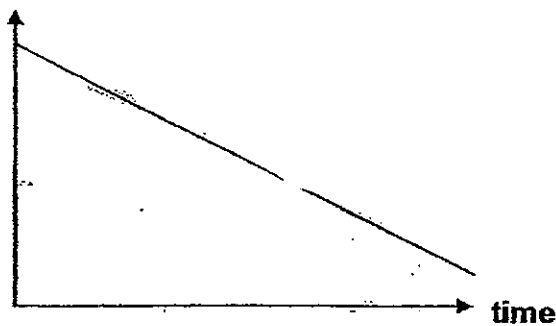

(aii) Explain the graph that you have drawn in (i). [1]

---



---

(b) State 2 changes that will take place in a flower after fertilisation has taken place. [1]

(i) \_\_\_\_\_  
 \_\_\_\_\_

(ii) \_\_\_\_\_  
 \_\_\_\_\_

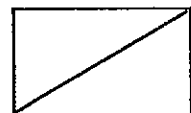

36. The flow chart below shows the characteristic of different plants as listed by J, K, L, M, and N

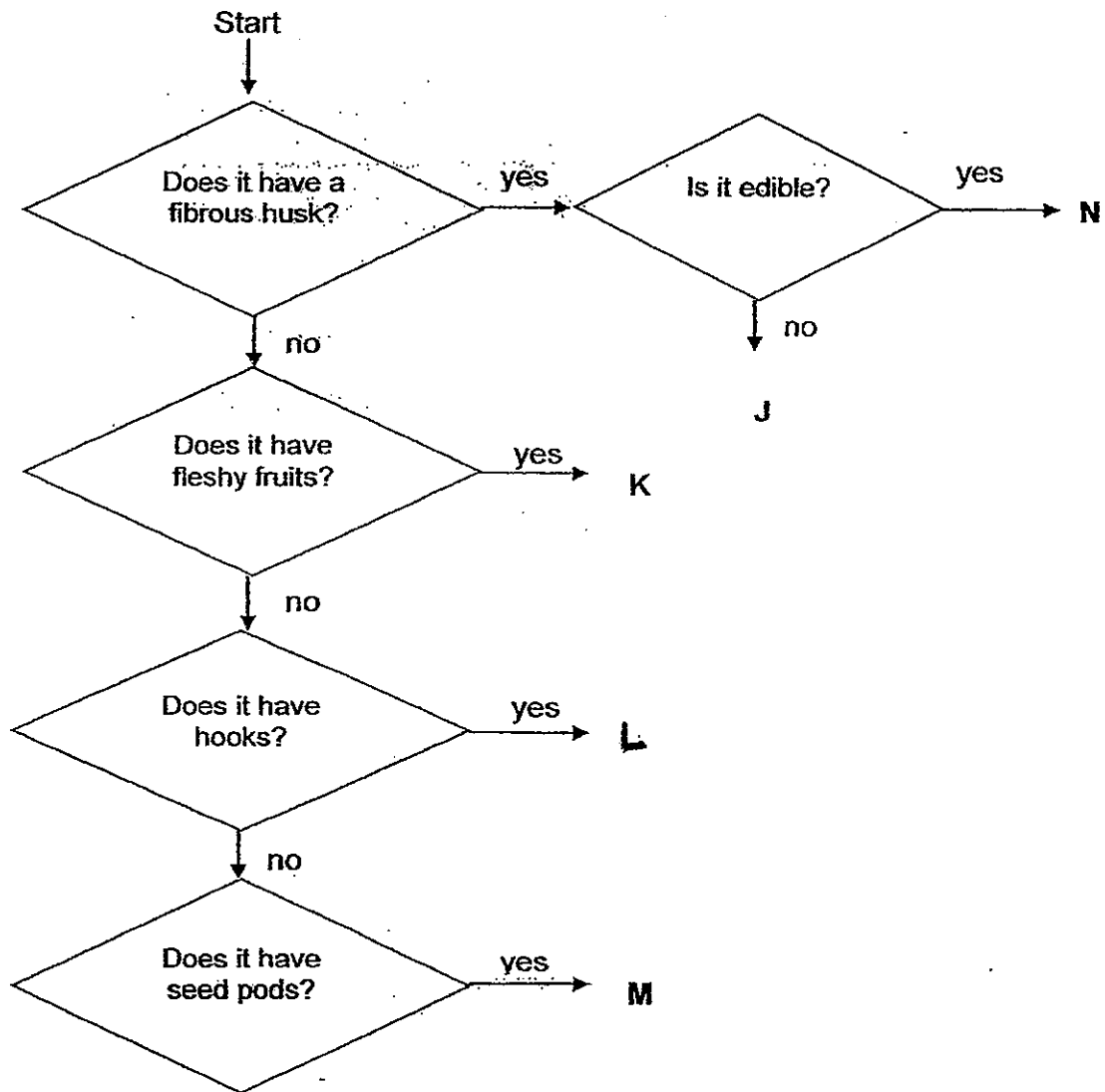

Match the plants below with the letters that best represent them. [2]

Plants	Letter
Mangosteen	
Pong pong	
African tulip	
Love grass	

37. Susan wanted to find out how the length of the wing-like structures of fruit Y below helps in the dispersal of its seeds.

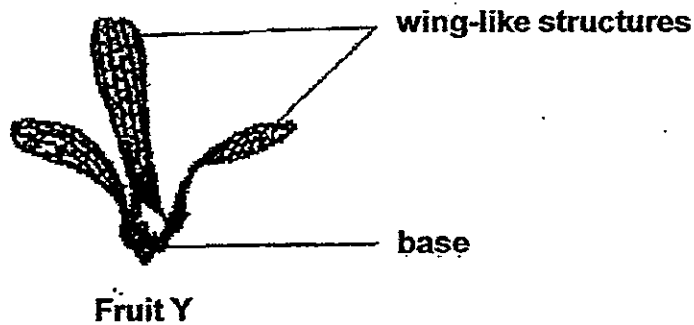

- (a) Using only the items provided below, list the steps for her to carry out an experiment to determine if the wing-like structures helped in the dispersal of Fruit Y. [2]

Items provided:

- fruit Y
- measuring tape
- scissors

Steps	Procedure
1	Hold the fruit at the base at a height of 1m from the ground and stand 30cm in front of a table fan.
2	
3	
4	Cut the wings of the fruit with a pair of scissors.
5	Repeat steps 1 - 3 for the modified fruit obtained from step 4.

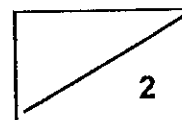

- (b) Based on the experiment that she had carried out in (a), write down a possible conclusion for the experiment. [1]

---

---

---

- (c) State one benefit for the fruit when it stays in the air for a longer time. [1]

---

---

---

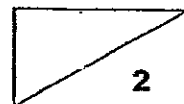

38. During his Science lessons, Roy learnt that when cells take in water, they swell. He then conducted an experiment and observed that when some cells from Organism T were placed in pure water, the cells swelled. However, when similar cells were placed in salt solution, they shrank.

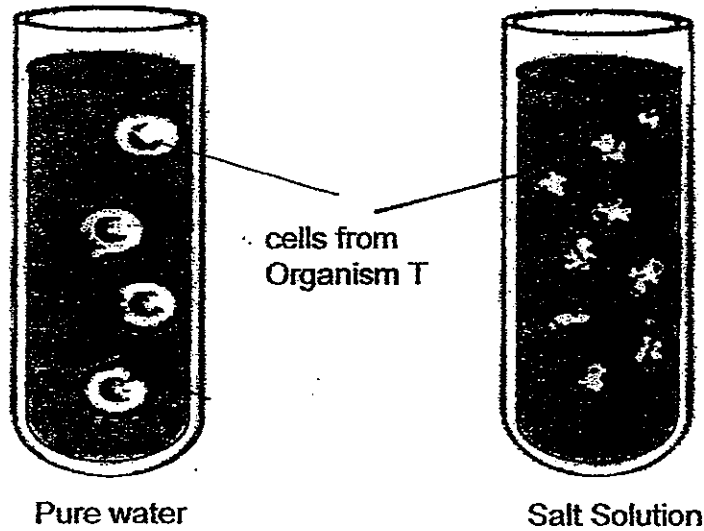

- (a) What conclusion can Roy make about the cell membrane of Organism T from the above experiment? [1]

---

---

---

Roy carried out another experiment with a plant cell and an animal cell. He placed both cells in pure water and examined them. One of the cells burst. The other cell became firm but did not burst.

- (b) Which cell did not burst? Explain your answer. [2]

---

---

---

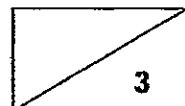

three

39. The diagram below shows how ~~four~~ different types of cells, A; B and C, look like under a microscope.

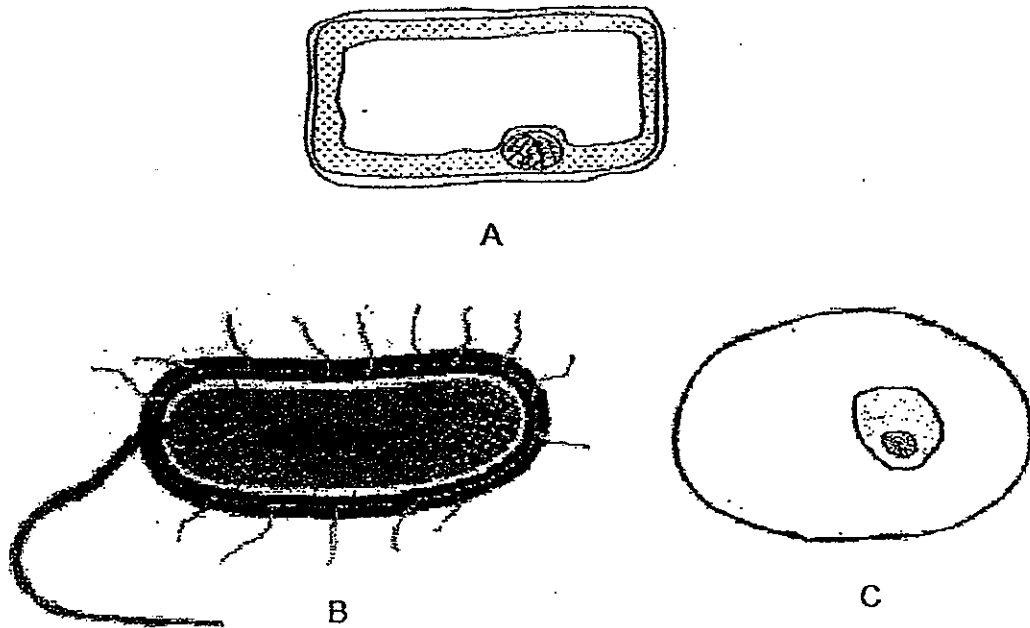

Based on the diagrams above, write letters A, B and C correctly in the flow chart below.

[1]

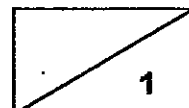
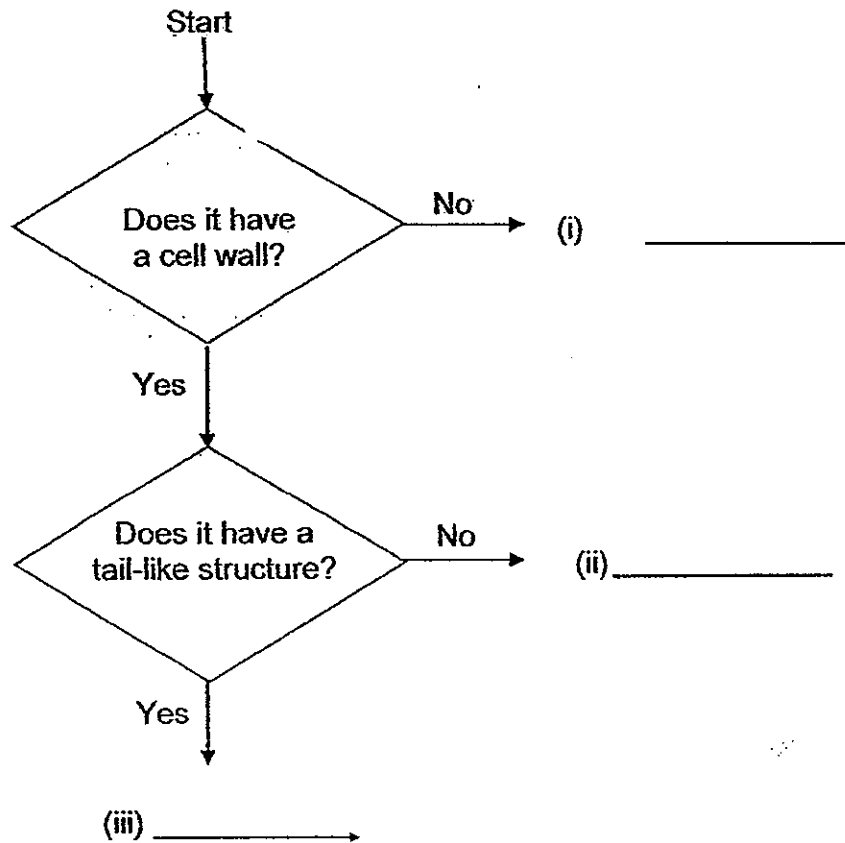



40. During a Science lesson, Keith was required to prepare two cell specimens from a potato plant. The diagram below showed the parts of the potato plant which specimens A and B were obtained from.

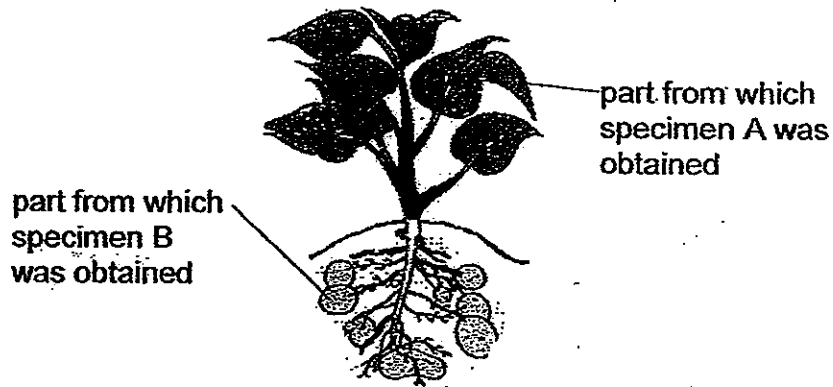

Keith prepared both specimens A and B on two separate slides.

- (a) Fill in the table below with a tick (✓) to show what Keith would be able to observe under the microscope. [1]

Parts of a cell	Specimen A	Specimen B
Nucleus		
Cell wall		
Cell membrane		
Cytoplasm		
Chloroplasts		

- (b) What is the function of chloroplasts in the potato plant? [1]

---



---

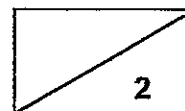

41. The diagram below shows a cell from a multicellular organism that Thomas was given. His teacher had removed one part from the cell. He was asked to identify if the cell was from an animal or a plant.

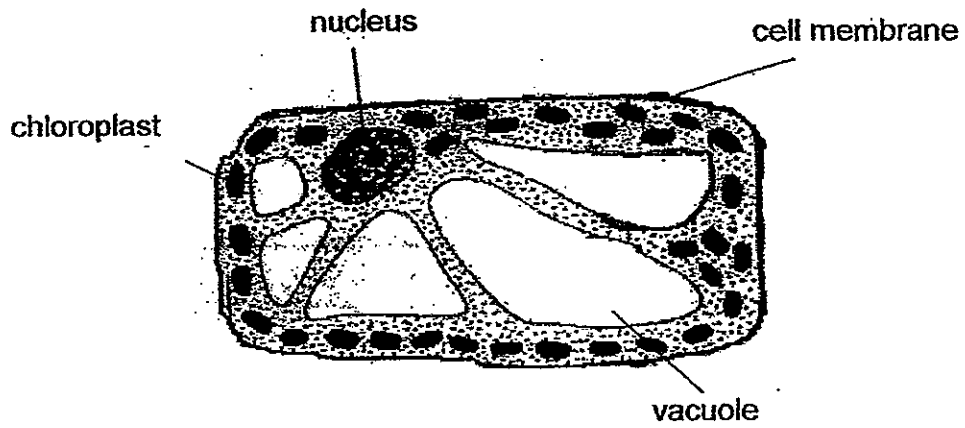

- (a) Which part of the cell had his teacher removed? Explain your answer. [1]

---

---

- (b) Besides the part which was removed, state another part of the cell above that would enable Thomas to confirm if the cell was from an animal or a plant? Give a reason for your answer. [1]

---

---

---

42. The diagram below shows a process that takes place in multicellular organisms.

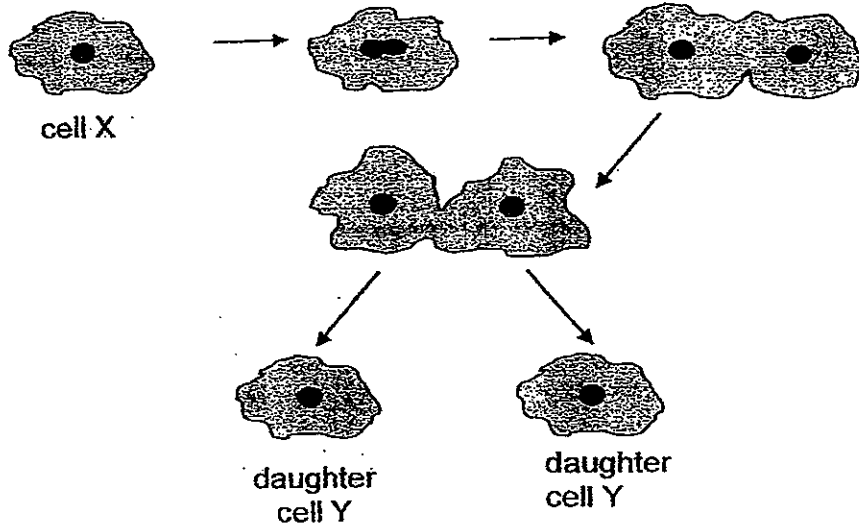

- (a) Name the process shown above. [1]

\_\_\_\_\_

- (b) State 2 purposes for cells to undergo the process above. [2]

(i) \_\_\_\_\_  
\_\_\_\_\_

(ii) \_\_\_\_\_  
\_\_\_\_\_

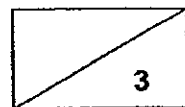

43. Halim carried out an experiment on a plant as shown below. He had made 2 different cuts on the stem and observed leaf A and leaf B for a week. In cut 1, only the food-carrying tube was removed. In cut 2, both the food and water carrying tubes were removed.

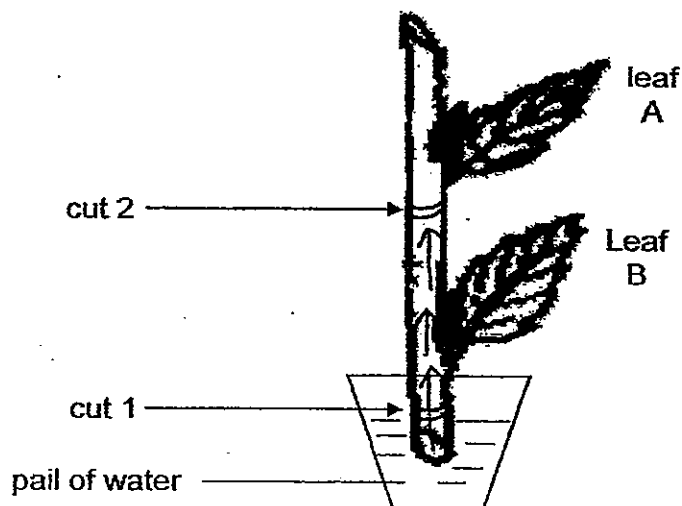

- (ai) What observation would be made of Leaf A and Leaf B after a week? [1]

---

---

- (aii) Explain your answer for part (i). [2]

---

---

---

---

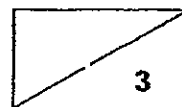

44. Ahmad set up an electrical circuit with an iron nail hanging at equal distance between two identical iron rods, A and B. The wire in each circuit was coiled 20 times around rod A but only 10 times around rod B.

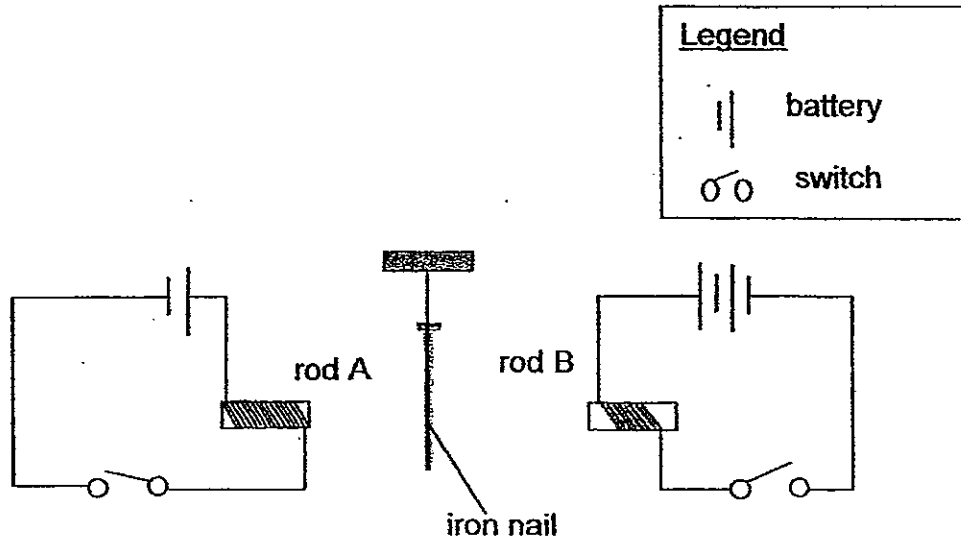

The aim of Ahmad's experiment was to find out how the number of coils would affect the strength of the electromagnet.

- (a) State the hypothesis of the experiment. [1]

---



---

- (b) Has Ahmad conducted a fair test? Explain your answer. [1]

---



---

- (c) Ahmad decided to replace the iron rod B with an aluminium rod.

State and explain the observation that Ahmad would make after the change. [2]

---



---



---

~ End of paper ~

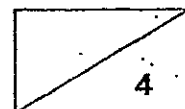

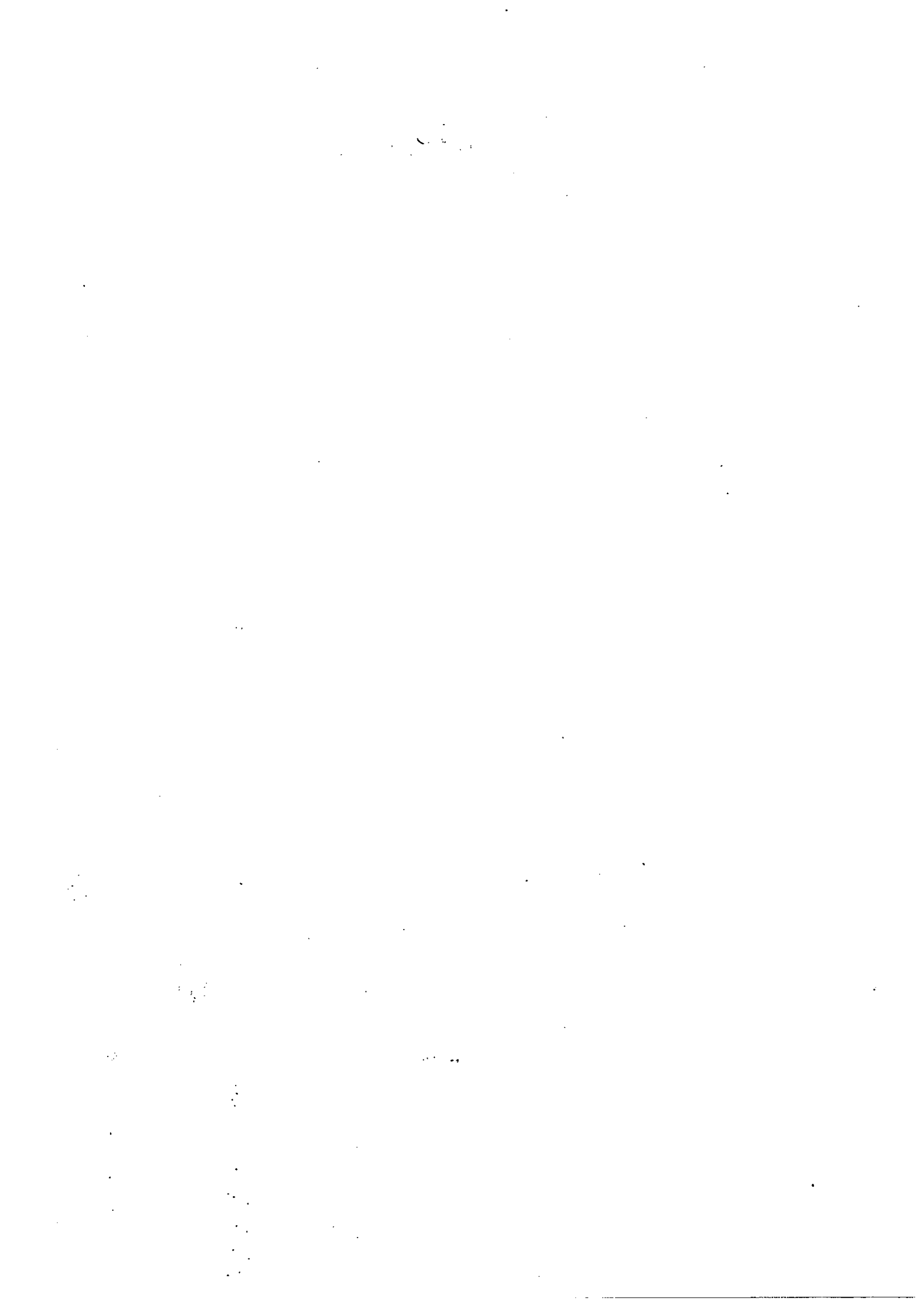

# ANSWER SHEET

EXAM PAPER 2012

SCHOOL : NANYANG  
SUBJECT : PRIMARY 5 SCIENCE

TERM : SA2

Q1	Q2	Q3	Q4	Q5	Q6	Q7	Q8	Q9	Q10	Q11	Q12	Q13	Q14	Q15	Q16	Q17
4	3	4	2	4	3	3	2	2	1	1	2	3	1	1	1	2

Q18	Q19	Q20	Q21	Q22	Q23	Q24	Q25	Q26	Q27	Q28	Q29	Q30
2	2	3	1	3	1	2	4	4	3	4	3	3

- 31)a)The duration of exercise is, the number of heart beats increases.  
However, at eight minutes the number of heart beats stat to remain constant.
- b)i)When he exercises the body needs more oxygen to be transported to all parts of the body to break down food and produce the extra energy needed.  
ii)Get rid the extra  
c)If heart beat increases breathing rat<sub>λ</sub> also increase.
- 32)ai)The aim of Nicholas' experiment is to find out how the average number of times the fish opened and closed its gill covers changes with the decreasing level of dissolved oxygen.  
ii)As time passes by, dissolved oxygen is reduced, the average number of times.  
b)The amount of oxygen in the water in the tank is reduced and the gold fish had to open and gill cover more times to get more oxygen.  
c)Blood vessel X is rich in oxygen while blood vessel Y is poor in oxygen.
- 33)a)The lungs take in air from the atmosphere while the gills take in air that is dissolved in water.  
b)They both have a large surface area of blood vessels to allow gaseous exchange more efficiently.

34)a)i) → →

ii)The stoma would release water vapour into the surrounding air.

b)Water moves in one way in plants while the blood circulate through out the body.

35)a)i)

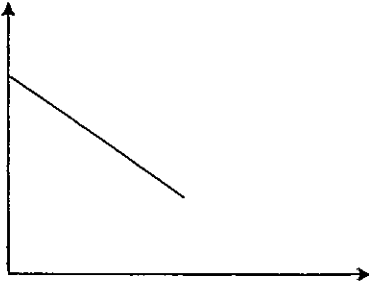

ii)Without the petals to pollinators, the rate of fertilised of the flowers to decrease, Hence, there will be lesser fruits.

b)i)The petals would drop.

ii)The ova would become into a fruit.

36)K J M L

37)a)2)Drop the fruit

3)Record the results

b)The fruit with wings will travel a longer distance than the one without wings.

c)It allows the fruit to go further away from the parent plan to prevent over crowding and competition.

38)a)The cell membrane allows water to enter the cell but does not allows salt solution to enter.

b)The plant cell did not burst. The plant cell has a cell wall which helps to protect the cell from bursting.

39)i)C ii)A iii)B

40)a) ✓ ✓  
✓ ✓  
✓ ✓  
✓ ✓  
✓

b)It is to trap light to make food.

41)a)She had removed the cell wall, some plant cells has chloroplast and therefore it is an plant cell. All plant cells has cells however the cell he was given had no cell wall.



41)b)It has chloroplast. Only plant cells have chloroplasts.

42)a)Cell division.

b)i)To replace old and damaged ones.

ii)To enable the body to grow.

43)a)i)Leaf B would still be alive while Leaf A would wither.

ii)All Living things need food, water and air, Leaf A has no water while Leaf B has water.

44)a)The more the number coils, the stronger the electromagnet.

b)No, He change two variables therefore he was not conducting a fair test.

c)The iron nail will move towards the iron rod A Iron is a magnetic material but not aluminium Rod A will be a magnet but not a rod B, so only rod A will be come an electromagnet an d attract the iron nail.

