

H1ANDERSON JUNIOR COLLEGE
HIGHER 1

BIOLOGY**8875/01**

Paper 1 Multiple Choice

19 September 2017
Tuesday

Additional Materials: Multiple Choice Answer Paper

1 hour
30 marks

READ THESE INSTRUCTIONS FIRST

Write in soft pencil.

Do not use staples, paper clips, highlighters, glue or correction fluid.

Write your name, PDG and identification number on the Answer Sheet.

There are **thirty** questions on this paper. Answer **all** questions. For each question there are four possible answers **A, B, C** and **D**.Choose the **one** you consider correct and record your choice in **soft pencil** on the separate Answer Sheet.Each correct answer will score one mark. A mark will not be deducted for a wrong answer.
Any rough working should be done in this booklet.

Calculators may be used.

1 An electron micrograph of a cell is shown below.

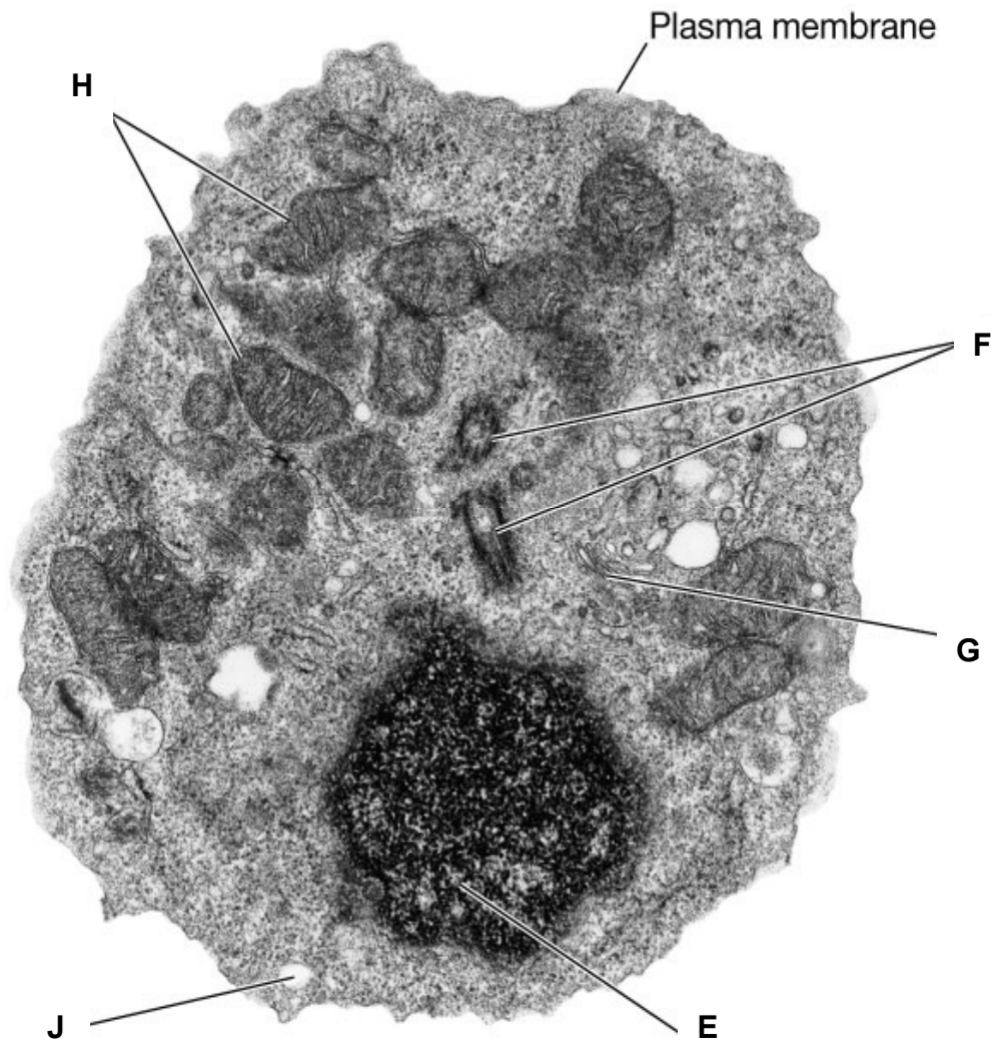

Match the organelles **E**, **F**, **G**, **H** and **J** associated with the cellular processes listed.

	E	F	G	H	J
A	DNA replication	Digestion of materials	Organises the spindle fibre	Oxidative phosphorylation	Packaging of secretory products
B	Oxidative phosphorylation	Organises the spindle fibre	Digestion of materials	DNA replication	Packaging of secretory products
C	Organises the spindle fibre	Digestion of materials	Oxidative phosphorylation	Packaging of secretory products	DNA replication
D	DNA replication	Organises the spindle fibre	Packaging of secretory products	Oxidative phosphorylation	Digestion of materials

- 2 Which of the following are the most likely consequences for a cell lacking functional Golgi bodies?
1. The cell dies because it is unable to make glycoproteins to detect stimuli from its environment.
 2. The cell dies from a lack of enzymes to digest food taken in by endocytosis.
 3. The cell dies from the accumulation of worn-out organelles within itself.
 4. The cell is unable to reproduce itself.
 5. The cell is unable to export its enzymes or peptide hormones.

- A** 1 and 5
B 2 and 3
C 1, 2, 3 and 4
D 1, 2, 3 and 5

- 3 Three pure substances are analyzed. The table shows the elements that each contains.

	C	H	O	N	P	S
X	+	+	+	+	-	-
Y	+	+	+	-	-	-
Z	+	+	+	+	-	+

Which of the following combination best describes **X**, **Y** and **Z**?

	X	Y	Z
A	adenine	carbohydrate	fat
B	adenine	fat	an amino acid
C	an amino acid	fat	carbohydrate
D	fat	carbohydrate	an amino acid

- 4 A student uses centrifugation to separate the various subcellular structures of human epithelial cells by size and density. Which of the following molecule(s) would you expect to find in the pellet containing the cell membrane?

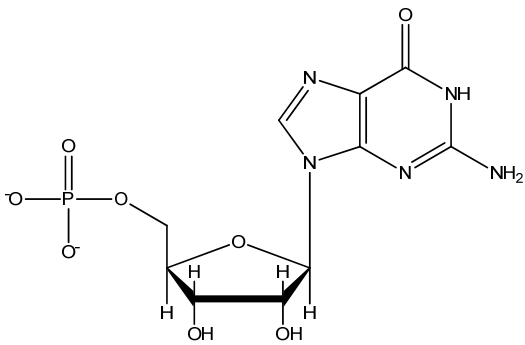

I

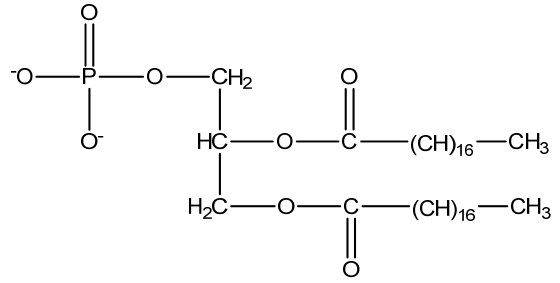

II

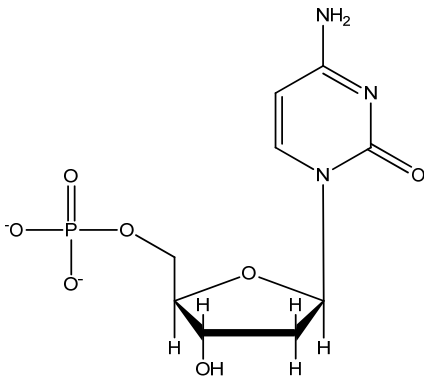

III

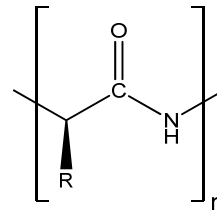

IV

- A II only
 B III only
 C II and IV only
 D I, III and IV only

5 Curve P represents the course of an enzyme-catalyzed reaction under optimum conditions. Curves Q and R show the action of the same enzyme on the same substrate but with the addition of a competitive and a non-competitive inhibitor respectively. Assume that the starting amount of enzyme and substrate is the same for all three curves.

Which of the following pairs of graphs correctly shows the effects of competitive and non-competitive inhibitors on the reaction?

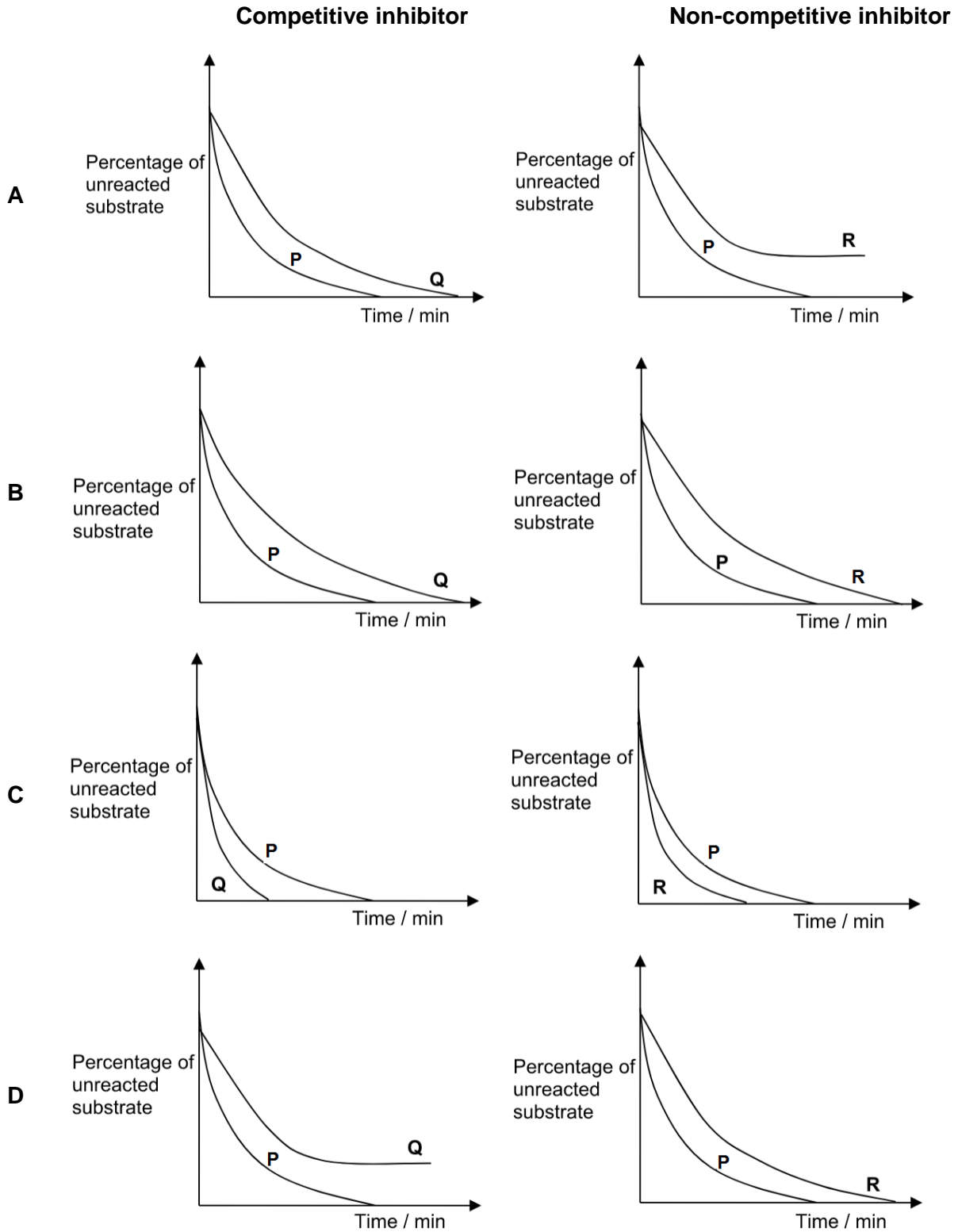

- 6 The graph below shows the quantity of the product formed when samples containing the same concentration of enzyme and substrate were kept at different temperature for four different durations.

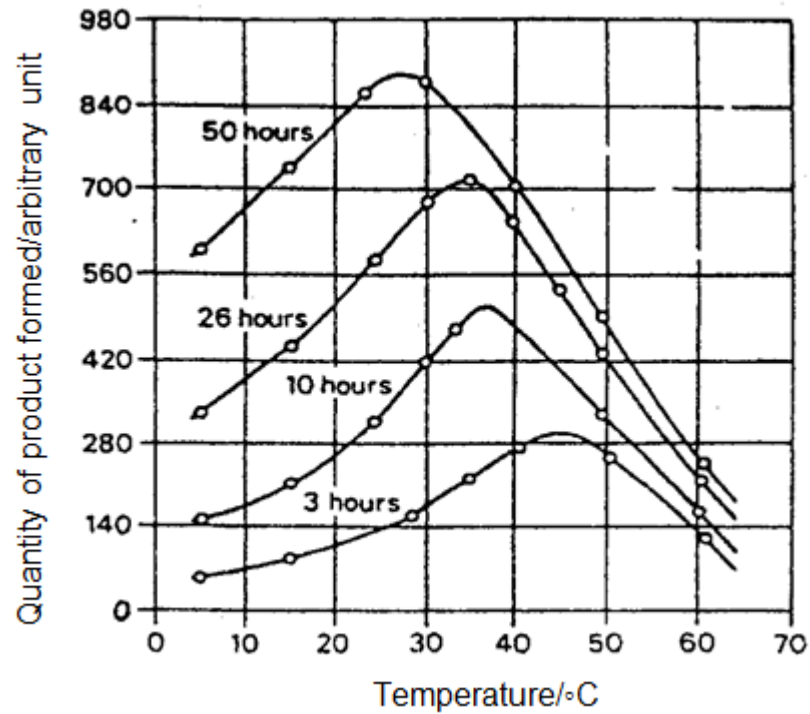

Which statement best explains why the optimum temperature is lowered if the duration of incubation is increased?

- A There is an increase in the denaturation of enzymes at high temperature.
- B The activation energy of the reaction is lowered at high temperature.
- C The product formed as an allosteric activator to enhance enzyme activity.
- D More substrates are converted into products for longer durations of incubation.

7 Which diagrams show the correct relationships?

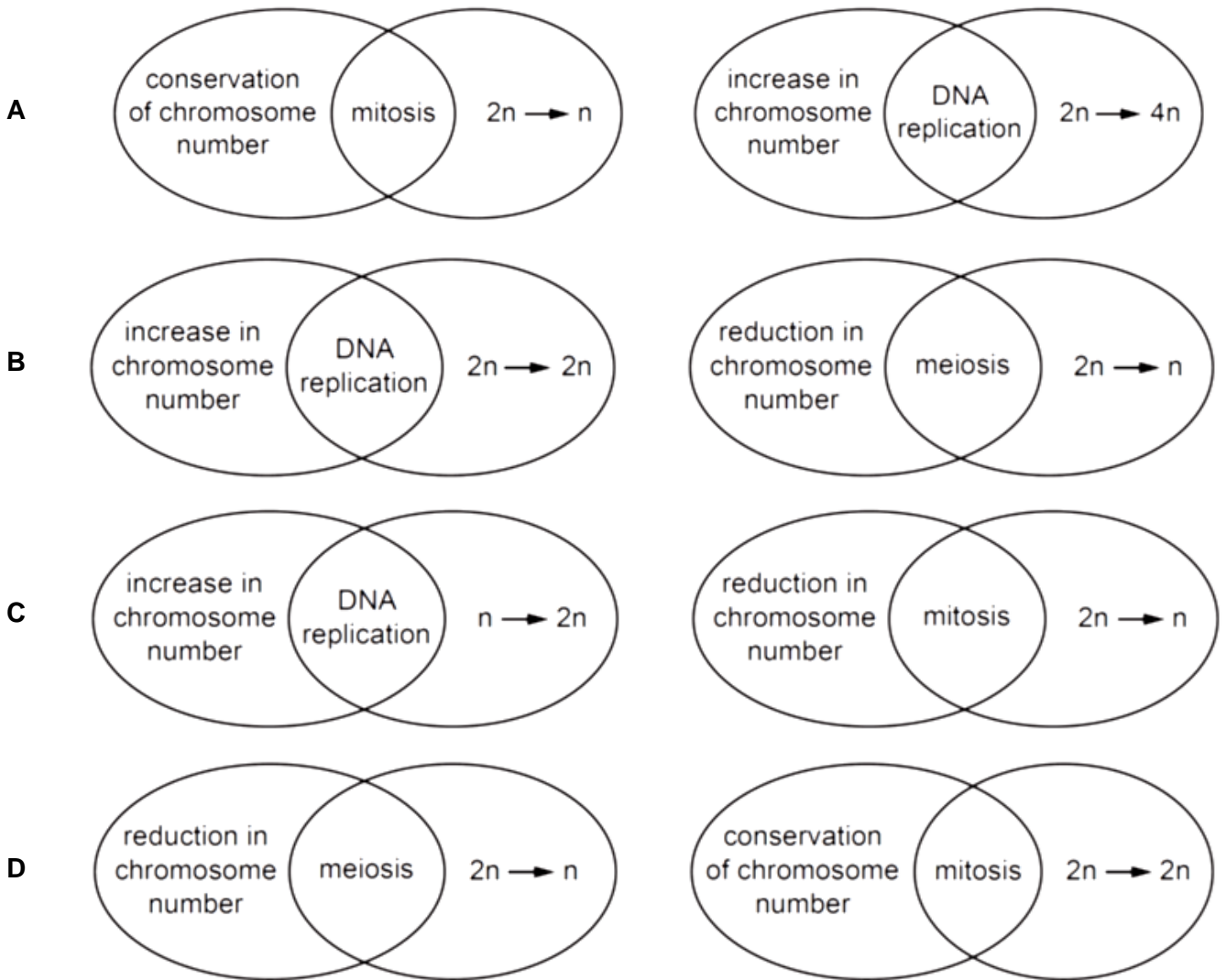

- 8 The amount of DNA in a mammalian cell in early prophase I of meiosis is X . What is the amount of DNA in the same cell at G1 of interphase ?
- A 0.25X
 B 0.5X
 C X
 D 2X
- 9 DNA replication is illustrated in the following figure.

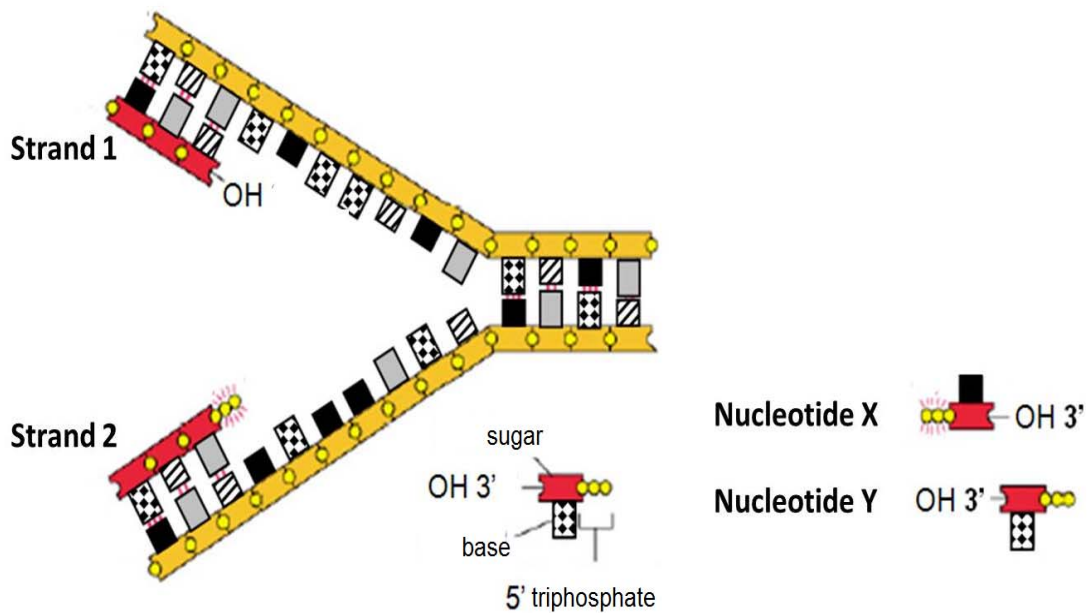

Which of the following correctly describes the addition of the next nucleotide in the DNA strands undergoing replication?

- A Nucleotide **X** will be added to the leading strand, which is strand 1.
 B Nucleotide **Y** will be added to the leading strand, which is strand 1.
 C Nucleotide **X** will be added to the lagging strand, which is strand 1.
 D Nucleotide **Y** will be added to the leading strand, which is strand 2.

10 The diagrams show an investigation into semi-conservative replication of DNA.

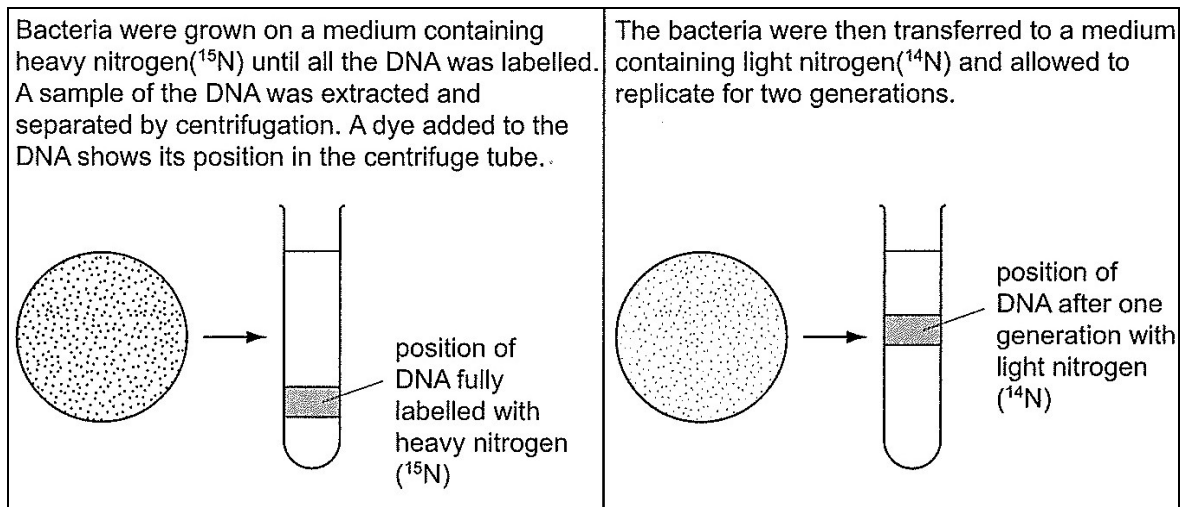

Which tube shows the position of the DNA after two generations of semi-conservative replication in light nitrogen (^{14}N)?

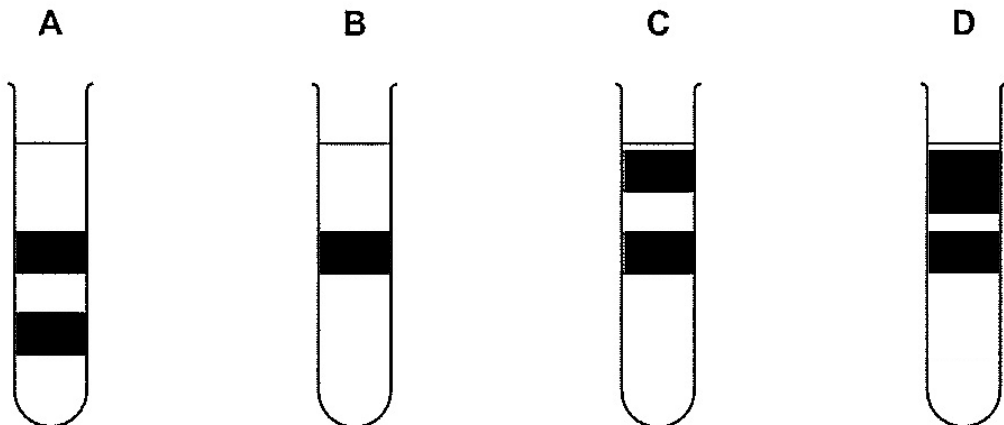

- 11 CFTR is a transmembrane regulator protein. It is made up of 1480 amino acids. People with cystic fibrosis produce a defective CFTR protein which is missing one amino acid from its structure. The diagram shows the synthesis of a normal and a defective CFTR in a cell. A normal CFTR protein molecule has sugar molecules attached to it which make it functional.

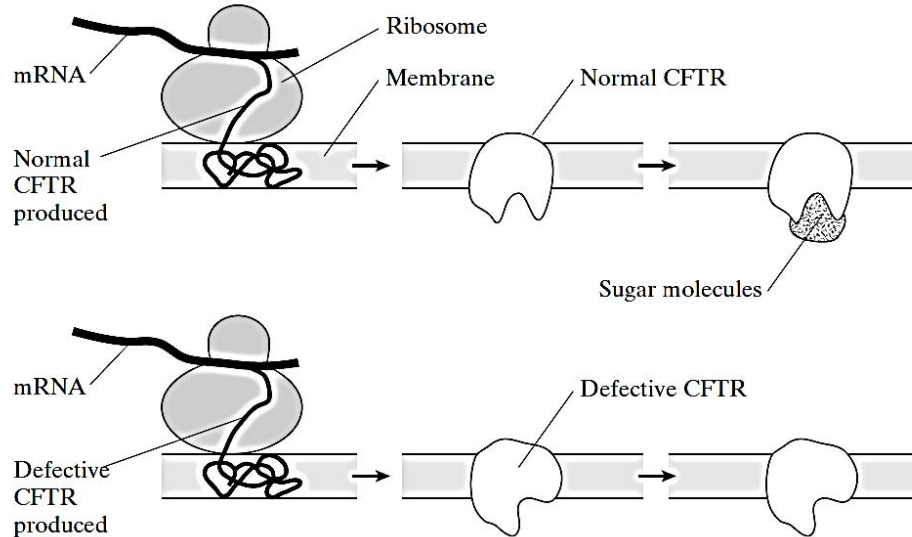

Which of the following statements are true?

1. 4440 is the number of bases on the template DNA which code for the amino acid sequence of a normal CFTR protein.
2. Cystic fibrosis is due to a chromosomal mutation known as a deletion.
3. The functional CFTR is a protein that undergoes glycosylation.
4. The defective CFTR is not functional as the mutation in the DNA resulted in changes in its tertiary structure.

- A** 1 and 4 only
- B** 1 and 3 only
- C** 1, 3 and 4 only
- D** 2, 3 and 4 only

- 12** An antibiotic, edeine, was isolated. It inhibits protein synthesis but has no effect on either DNA synthesis or RNA synthesis. When added to a translation mixture containing fully intact organelles, edeine stops protein translation after 10 seconds.

Analysis of the edeine-inhibited mixture by centrifugation showed that no polyribosomes remained by the time protein synthesis had stopped. Instead, all the mRNA accumulated, together with small ribosomal subunit and initiator tRNA.

What step in protein synthesis does edeine inhibit?

- A** It blocks translocation of the ribosome along the mRNA.
 - B** It interferes with chain termination and release of peptide.
 - C** It prevents formation of the translation initiation complex.
 - D** It inhibits binding of amino-acyl-tRNAs to the A site of the ribosome.
- 13** Seeds from a pure breeding plant were planted in identical pots of compost and watered regularly. Sets of ten pots were placed in different light conditions and left until the first leaves had developed.

The table shows the mean height for the young stems, mean length of first leaf and the colour of the leaves.

	no light	dim light	bright light
mean height / cm	8	6	4
mean leaf length / cm	1.5	1.4	1.4
colour of leaves	pale yellow	pale green	dark green

Which explains the effect of light on the phenotype of the young plants?

- A** The activity of genes involved in chlorophyll synthesis and stem growth varies with light intensity.
- B** The activity of genes involved in stem and leaf growth is decreased by light
- C** The genes involved in chlorophyll synthesis and stem growth are activated by light.
- D** The genes involved in chlorophyll synthesis and stem growth are inactivated by light.

- 14 Fruit flies (*Drosophila*), homozygous for long wings, were crossed with fruit flies homozygous for vestigial wings. The F₁ and F₂ generations were raised at three different temperatures.

At each temperature, the F₁ generation all had long wings.

The table shows the results in the F₂ generation.

temperature / °C	result
21	$\frac{3}{4}$ long wings, $\frac{1}{4}$ vestigial wings
26	$\frac{3}{4}$ long wings, $\frac{1}{4}$ intermediate wing length
31	all long wings

Which statement explains these results?

- A Heterozygous flies have vestigial wings only at 21°C or below but have long wings at 31°C or above.
- B Long wing and vestigial wing illustrate codominance at 26°C.
- C Long wing is dominant at higher temperatures but vestigial wing is dominant at lower temperatures.
- D Vestigial wing is recessive but causes a vestigial wing phenotype only at lower temperatures.
- 15 In rabbit, there are two alleles for fur colour, grey and white, and two alleles for fur length, short and long. Two pure-breeding rabbits were mated, and the F₁ offspring all had grey and long hair. When the F₁ offspring were selfed, they produced the following numbers of F₂ offspring:

grey and long haired:	92
grey and short haired:	32
white and long haired:	28
white and short haired:	13

Which of the following are true?

- The genes for fur colour and fur length assort independently.
 - The probability of producing pure-bred offspring is 1 in 16.
 - The original pure-breeding parents must be only grey and long haired, and white and short haired.
 - The two traits show sex-linked inheritance.
- A 1 only.
- B 2 and 3
- C 1 and 3
- D 2, 3 and 4

- 16 Three of the graphs below show the absorption spectra of photosynthetic pigments. One graph shows the action spectrum of photosynthesis for a plant containing the pigments.

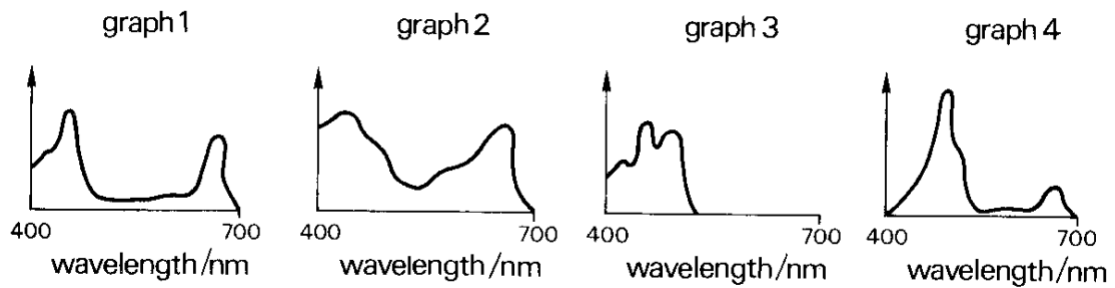

All the x axes show wavelength. Three of the y axes show light absorption. One y axis shows the rate of photosynthesis.

Which of the following identifies the four graphs?

Absorption spectra				
	Chlorophyll a	Chlorophyll b	Carotenoids	Action spectrum
A	1	4	3	2
B	2	1	3	4
C	3	2	4	1
D	4	2	1	3

17 The blue dye DCPIP can be converted to colourless DCPIP as shown below:



A suspension of chloroplasts was made by grinding fresh leaves in buffer solution and centrifuging the mixture. Tubes were then prepared and treated in the following ways.

Tube	Contents	Treatment	Colour	
			At start	After 20 minutes
1	1 cm ³ chloroplast suspension + 5 cm ³ DCPIP	Illuminated strongly	Blue green	Green
2	1 cm ³ buffer solution + 5 cm ³ DCPIP	Illuminated strongly	Blue	Blue
3	1 cm ³ chloroplast suspension + 5 cm ³ DCPIP	Left in the dark	Blue green	Blue green

Which one of the following statements is a possible conclusion for the observation above?

- A Photolysis of water produces oxygen which oxidizes DCPIP.
- B Respiration consumes oxygen from the suspension, hence DCPIP is partially reduced.
- C Light reaction which occurs in the chloroplasts yield free electrons which reduce DCPIP.
- D Either strong illumination or the buffer solution used in the extraction of chloroplasts could oxidize DCPIP.

18 Below are some statements about anaerobic respiration in yeasts and animal cells.

1. Pyruvate acts as the alternative hydrogen acceptor.
2. Carbon dioxide is produced.
3. Oxidation of reduced coenzyme occurs
4. ATP is synthesized.

Which statements apply to animal cells and yeast cells?

	Animal cells	Yeast
A	1, 2 and 3	3 and 4
B	1, 3 and 4	2, 3 and 4
C	2, 3 and 4	1, 2, 3 and 4
D	1, 2 and 3	2 and 3

19 Two test tubes containing the following contents are shown below:

Tube 1:

Radioactive glucose solution + yeast cells suspension + oxygen + antimycin

Tube 2:

Radioactive glucose solution + yeast cells suspension + oxygen

Radioactive glucose has all its six carbons made of radioactive ^{14}C . The initial radioactivity measured for the glucose in each test tube is 60 arbitrary units.

Antimycin is an electron transport chain inhibitor.

If the gaseous product and the aqueous products are tested using a radioactive meter after all the glucose has been metabolized, what would be the final observed readings?

	Tube 1 (radioactivity measured/ arbitrary units)		Tube 2 (radioactivity measured/ arbitrary units)	
	aqueous products	gaseous products	aqueous products	gaseous products
A	0	60	40	20
B	20	40	0	60
C	40	20	0	60
D	40	20	60	0

- 20** The diagram below shows the bone structures of the human arm, mouse forelimb and bat wings as well as the morphology of the wings of bat, butterfly and birds.

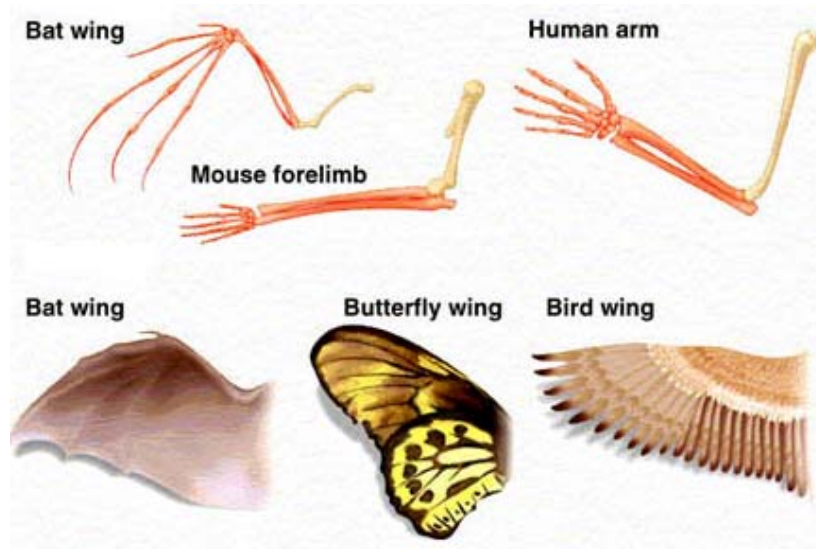

Which of the following are correct conclusions made from the diagram provided?

1. Bat, mouse and human share a common ancestor as their bone structure exhibit anatomical homology.
 2. Variations in the bone morphology of bats, mouse and human are due to natural selection.
 3. Bat, butterfly and bird share a recent common ancestor as shown by their common wing morphology.
 4. Bat, butterfly and bird exhibit analogous structures.
- A** 1 and 2
B 2 and 3
C 1 and 4
D 1, 2 and 4

- 21** A large population of a certain species of freshwater fish lives in a South America lake. If there are no mutations and all immigration into the population is prevented, which one of the following statements best expresses the probable future of the population?
- A** All evolution will promptly cease because without mutation, there will be no raw material for evolution.
 - B** The population will begin to decrease in size after three to four generations because of excessive inbreeding that will result from the absence of immigration.
 - C** The population will continue to evolve as selection acts on the different allelic combinations formed during meiosis.
 - D** The population will cease to evolve and it may survive for a long time as there is no selection.
- 22** What explains why genetic variation is important in selection?
- A** An increase in genetic variation in a population improves the chance of successful breeding
 - B** It allows those organisms with the best genotype to survive.
 - C** It gives alternative alleles that increase the gene pool of a species.
 - D** It results in different phenotypes that allow adaptation to occur.

- 23 The diagram shows the plasmid pUC18. Bacteria containing this plasmid produce blue colonies when grown in the presence of *X-gal*. Bacteria containing a genetically engineered recombinant pUC18 plasmid produce white colonies.

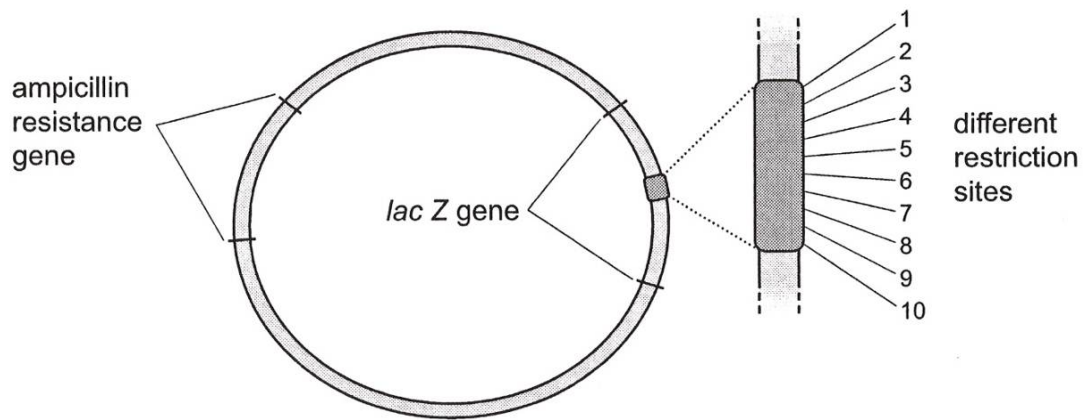

Some of the features of this plasmid are:

1. It is small and replicates to form about 500 copies per host cell.
2. It contains restriction sites for 10 different restriction enzymes.
3. It contains a gene giving resistance to the antibiotic ampicillin.
4. It contains the *lac Z* gene which allows the metabolism of *X-gal* to produce a blue colour.

A gene of interest was inserted into one of the restriction sites to form a recombinant plasmid. Bacteria were transformed with this recombinant plasmid and identified using a selective agar medium.

Which selective growth medium would identify the bacteria containing the recombinant plasmids?

- A A medium containing agar.
- B A medium containing ampicillin.
- C A medium containing ampicillin and *X-gal*.
- D A medium containing *X-gal*.

- 24** The *F8* gene is over 185 000 base pairs long and codes for Factor VIII, which is used during blood clotting.

People with a mutation of the *F8* gene have the condition haemophilia and are treated using a recombinant Factor VIII, synthesised by mammalian cells.

Escherichia coli cells cannot be used to synthesise the recombinant Factor VIII as they cannot add carbohydrate to protein.

What can be deduced using only this information?

- A** Different mutations of the *F8* gene will lead to different severities of haemophilia.
 - B** Human factor VIII is a glycoprotein.
 - C** Human factor VIII is composed of 61 667 amino acids.
 - D** The *F8* gene is located on the X chromosome.
- 25** If a researcher began with a PCR on a sample that contained three copies of double stranded DNA, and each step in PCR takes 1 minute, how many copies would be present after 1 hour 21 minutes?

- A** 2^{27}
- B** 4^{27}
- C** $2^{3 \times 27}$
- D** 3×2^{27}

- 26** Some of the steps involved in DNA analysis are listed below:

- 1 transfer segments of DNA to nitrocellulose membrane
- 2 extraction of DNA
- 3 gel electrophoresis
- 4 treating DNA with restriction enzymes
- 5 autoradiography
- 6 hybridise with probe

The correct sequence is

- A** $2 \rightarrow 4 \rightarrow 3 \rightarrow 1 \rightarrow 6 \rightarrow 5$
- B** $4 \rightarrow 2 \rightarrow 3 \rightarrow 1 \rightarrow 6 \rightarrow 5$
- C** $4 \rightarrow 2 \rightarrow 1 \rightarrow 3 \rightarrow 6 \rightarrow 5$
- D** $2 \rightarrow 4 \rightarrow 3 \rightarrow 1 \rightarrow 5 \rightarrow 6$

- 27 Which of the following features of the embryonic stem cells and specialized cells shown in the diagram are true?

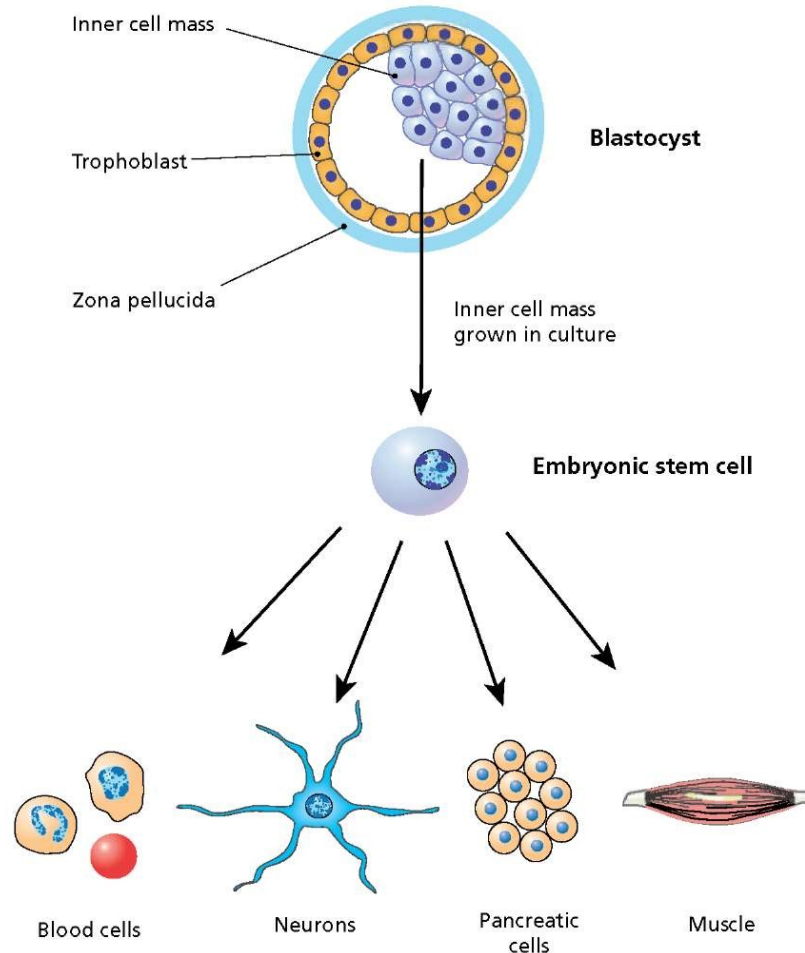

	Embryonic stem cells	Specialized cells
A	Embryonic stem cells display greater plasticity when grown in culture than when in blastocyst.	The blood cells are genetically different from the embryonic stem cells but have shorter telomeres.
B	Embryonic stem cells are pluripotent and are capable of transdifferentiating (convert one cell type to another) into many different cell types.	The pancreatic cells are genetically identical to the embryonic stem cells but with a different set of genes expressed.
C	Embryonic stem cells are multipotent and are capable of differentiating into limited range of cell types.	The blood cells are genetically different from the embryonic stem cells because different genes are expressed.
D	Embryonic stem cells are pluripotent and are capable of differentiating into many different cell types.	The pancreatic cells are genetically identical to the embryonic stem cells but have shorter telomeres.

- 28** In bone marrow, multipotent stem cells can be distinguished from precursors of blood cells which are synthesising proteins by the chromatin and organelles that they contain.
What are the features seen in cells that are synthesizing large quantities of protein?

	Chromatin	Ribosomes	Golgi size
A	clumped	few	large
B	clumped	many	small
C	dispersed	few	small
D	dispersed	many	large

- 29** Which uses of information from the human genome project are generally considered to be unethical?

- 1 an insurance company only giving cheap rates to people with genetic predispositions to fewer diseases
- 2 genetic archaeologists identifying the earliest forms of genes to show evolutionary relationships
- 3 cytologists developing tests for only some defective genes
- 4 doctors only giving specific drugs to block the actions of faulty genes to carriers of those genes
- 5 genetic counsellors giving specific lifestyle information only to people genetically predisposed to risks
- 6 parents choosing embryos for implantation only after prenatal tests for acceptable genes

- A** 1 and 3
B 1 and 6
C 2 and 5
D 3 and 4

30 *Bt* gene from *Bacillus thuringiensis* may be inserted into cotton plant cells to produce *Bt* cotton plants. Insecticide use and yield in India were compared for *Bt* cotton hybrid (*XBt*), the same hybrid X but without the *Bt* gene (*X_*), and another hybrid widely grown in that particular locality (Y). This process was repeated at more than 150 locations. The table below shows the results:

hybrid	<i>XBt</i>	<i>X_</i>	Y
mean number of sprays against insects that eat the cotton	0.6	3.7	3.6
mean number of sprays against sap sucking insects	3.6	3.5	3.5
yield / kg ha ⁻¹	1500.0	830.0	800.0

The following are the conclusions that are drawn from the data:

1. All insect pests are killed when they consume the *Bt* crop.
2. *Bt* cotton reduces the amount of pesticide used.
3. Both yield and quality of cotton from *XBt* crop improved.
4. *Bt* cotton increases cost effectiveness.
5. Both *X_* and Y hybrids contain susceptible genes to the pest.
6. *Bt* toxin is not found in the plant sap.

Which of the conclusions stated are **correct**?

- A 1, 2 and 3
- B 2, 3 and 5
- C 4, 5 and 6
- D 2, 4 and 6

H1 Bio P1 2017 Answers

1	D	16	B
2	D	17	C
3	B	18	B
4	C	19	C
5	A	20	D
6	A	21	C
7	D	22	D
8	B	23	C
9	A	24	B
10	C	25	D
11	C	26	A
12	C	27	D
13	A	28	D
14	D	29	B
15	A	30	D

H1ANDERSON JUNIOR COLLEGE
HIGHER 1

NAME

PDG

--	--	--	--

INDEX NUMBER

--	--

BIOLOGY**8875/02**

Paper 2 Core Paper

12 September 2017

Tuesday

2 hours

Additional Materials: Answer Paper

READ THESE INSTRUCTIONS FIRST

Write your name and PD group on all the work you hand in.
Write in dark blue or black pen.
You may use a soft pencil for any diagrams, graph or rough working.
Do not use paper clips, highlighters, glue or correction fluid.

Section AAnswer **all** questions.**Section B**Answer **either Question 4 or Question 5**.

All working for numerical answers must be shown.

At the end of the examination, fasten all your work securely together.

The number of marks is given in brackets [] at the end of each question or part question.

Calculators may be used

For Examiner's Use	
PAPER 1	
1-30	30 marks
PAPER 2	
<i>Section A</i>	<i>40 marks</i>
1	
2	
3	
<i>Section B</i>	<i>20 marks</i>
4 or 5	
PAPER 2	60 marks
<u>TOTAL</u>	<u>90 marks</u>

Section A

Answer **all** the questions in this section.

- 1 Fig 1.1 shows an outline of the first three stages of aerobic respiration.

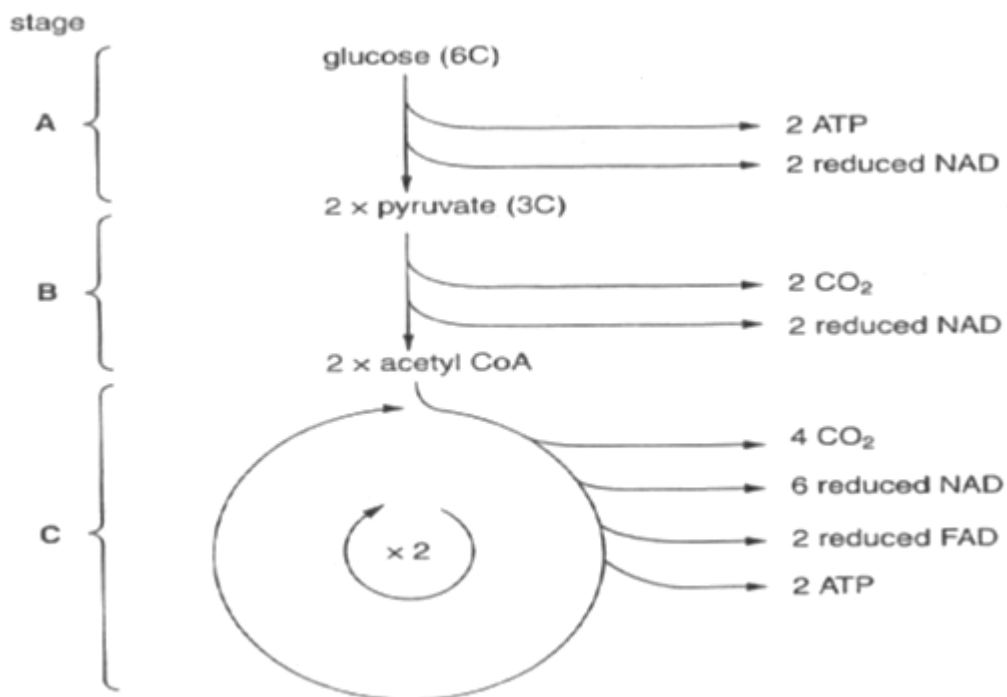

Fig. 1.1

- (a) For each glucose molecule, state the total number of molecules of ATP formed as a result of stages A to B, including any ATP produced through oxidative phosphorylation of the products. Assume that 1 reduced NAD synthesizes 2.5 ATP and 1 reduced FAD synthesizes 1.5 ATP. **Show your working.**

A:

B:

C:

- (b) Many enzymes are involved in Krebs cycle. An experiment was carried out to investigate the effect of temperature on respiration. Isolated liver mitochondria were placed in five reaction tubes, with contents and temperature of reaction tube as shown in Table 1 below. The corresponding rates of oxygen uptake were measured. Results are shown in Table 1.

Table 1

Tubes	Temperature/ °C	Volume of solution added/ cm ³		Rate of oxygen uptake / a.u
		Buffered isolated liver mitochondria	2% pyruvate solution	
1	35	Boiled and cooled	0.01	1.1
2	25	2.00	0.01	7.2
3	35	2.00	0.01	15.1
4	45	2.00	0.01	13.2
5	55	2.00	0.01	1.1

- (i) Enzymes are essential in helping to speed up the rate of metabolic reactions such as those in the Krebs cycle. Explain how enzymes help to speed up rate of reaction.

[4]

- (ii) Pyruvate has to be used as a substrate for this experiment instead of glucose. Explain why.

[2]

- 2 Fig. 2.1 shows a part of a pancreatic cell. The pancreas is important in regulating the level of blood glucose in the body by secreting insulin at high blood glucose level.

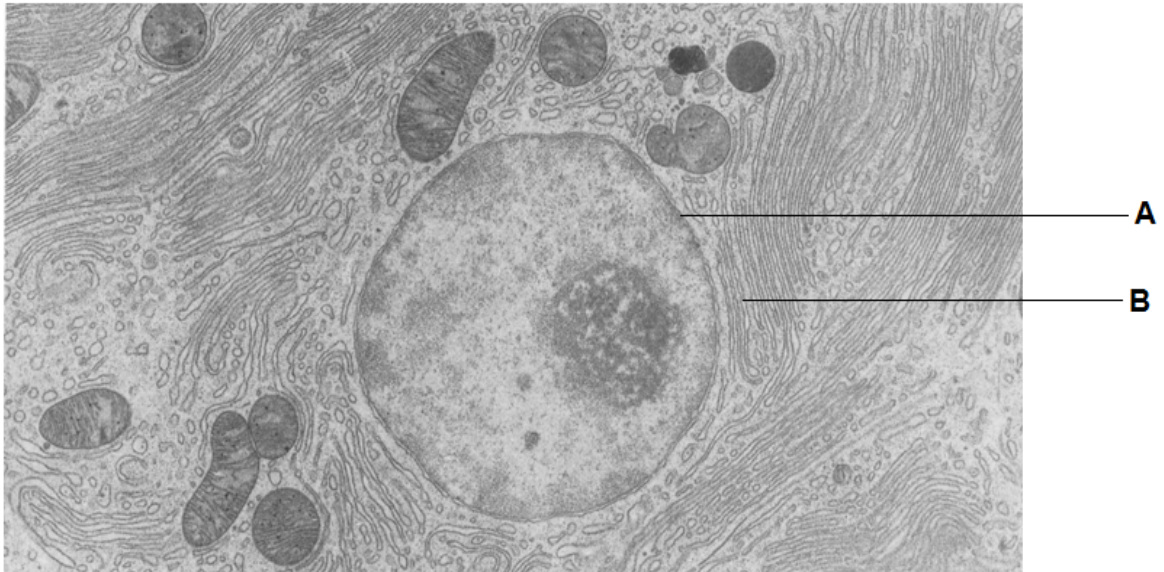

Fig 2.1

- (a) (i) State organelle A and B and describe the relationship between the two organelles in a pancreatic cell.

[3]

- (ii) State one other organelle you can observe in Fig. 2.1 and how it is important to the function of a pancreatic cell.

[1]

(b) Fig. 2.2 shows a diagrammatic depiction of the process that occurs at organelle B.

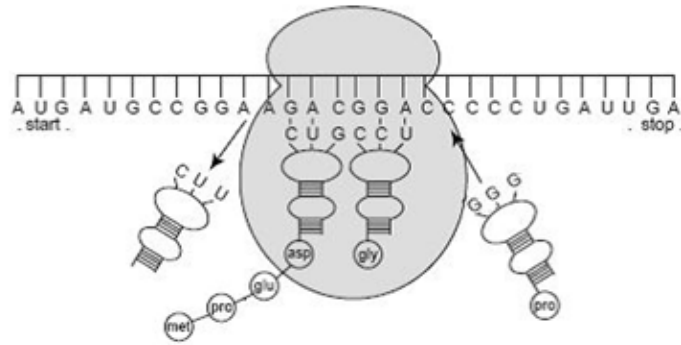

Fig. 2.2

Starting from the position of the ribosome as shown in Fig. 2.2, outline the steps that occur to produce the complete polypeptide.

- (c) Fig. 2.3A shows a DNA base sequence. It also shows the effect of two mutations on this base sequence. Fig. 2.3B shows DNA triplets that code for different amino acids.

Original DNA base sequence	A	T	T	G	G	C	G	T	G	T	C	T
Mutation 1 DNA base sequence	A	T	T	G	G	A	G	T	G	T	C	T
Mutation 2 DNA base sequence	A	T	T	G	G	C	C	T	G	T	C	T

Fig. 2.3A

DNA triplets	Amino acid
GGT, GGC, GGA, GGG	Gly
GGT, GTA, GTG, GTC	Val
ATC, ATT, ATA	Ile
TCC, TCT, TCA, TCG	Ser
CTC, CTT, CTA, CTG	Leu

Fig. 2.3B

Some mutations affect the amino acid sequences while others do not. Using the information in Fig. 2.2A and Fig. 2.2B and a **feature of the genetic code**, explain

- (ii) why mutation 1 has no effect on the protein structure

[3]

- (ii) why mutation 2 could lead to the formation of a non-functional enzyme.

[3]

[Total: 14 m]

3 (a) State the structural features of DNA that make it a stable molecule.

[2]

DNA polymerase is an enzyme involved in the replication of DNA.

One of the substrates required by DNA polymerase is ATP.

ara-ATP is a chemical that affects DNA polymerase activity.

In an investigation, the effect of different concentrations of ATP on the rate of DNA synthesis was determined:

- with no ara-ATP
- with a low concentration of ara-ATP
- with a high concentration of ara-ATP.

The results of the investigation are shown in Fig. 3.1.

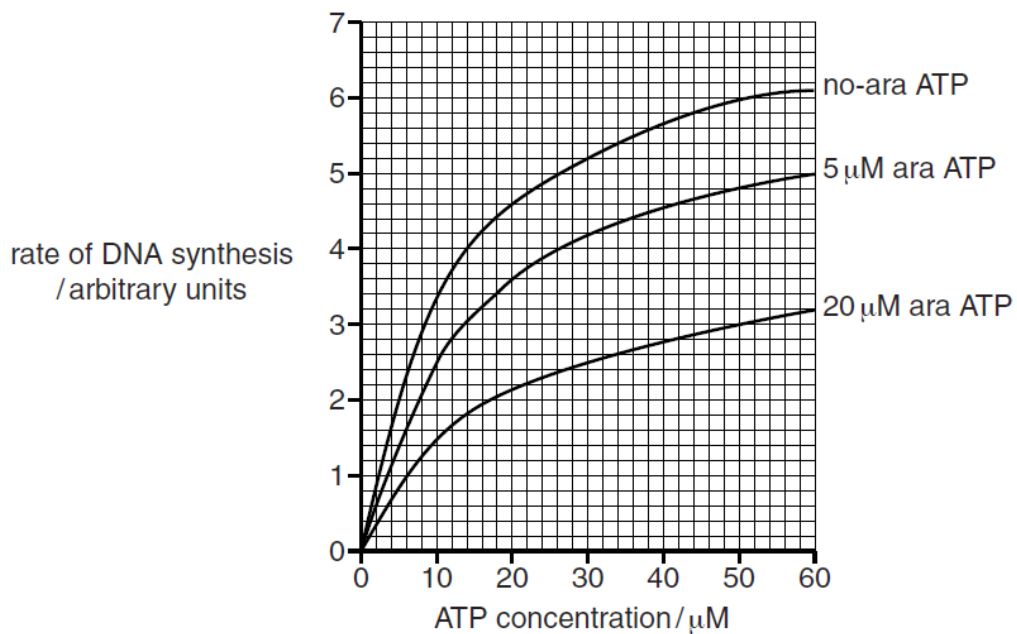

Fig. 3.1

(b) Explain the results of the investigation shown in Fig. 3.1 in terms of mode of action of enzymes.

[4]

Colour blindness is a genetic condition characterised by the inability of the brain to perceive certain colours accurately.

- The most common form is termed red-green colour blindness (RGC).
- RGC results from a recessive allele.
- 0.6% of females worldwide have RGC.
- 8.0% of males worldwide have RGC.

The results of the investigation are shown in Fig. 3.2.

□ = male ○ = female ■ = male with RGC

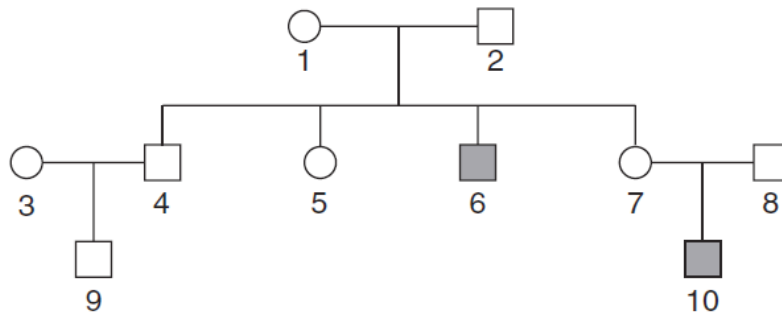

Fig. 3.2

(c) Define the term *recessive*.

[1]

(d) Explain why females are less likely than males to have RGC.

[2]

(e) With reference to Fig. 3.2, and using the symbols **R** for the dominant allele and **r** for the recessive allele, state the genotypes of the individuals **1** and **6**.

1 _____

6 _____

[2]

[Total: 11 m]

Section B
Answer EITHER 4 OR 5.

Write your answers on the separate answer paper provided.

Your answer should be illustrated by large, clearly labelled diagrams, where appropriate.

Your answers must be in continuous prose, where appropriate.

Your answers must be set out in section (a), (b) etc., as indicated in the question.

- 4 (a) Describe how gel electrophoresis separates DNA, and explain why it is useful in genetic fingerprinting analysis. [10]
- (b) Describe the features of zygotic stem cells and embryonic stem cells that distinguish them from each other. [3]
- (c) Discuss the social and ethical implications of genetically modifying plants. [7]

OR

- 5 (a) In Lake Tanganyika in Africa, there are six species of fish of the genus *Tropheus* and a much larger number of distinctly coloured subspecies of each of the six species. *Tropheus* species are small fish that are confined to isolated rocky habitats around the shores of Lake Tanganyika.

The six species evolved during the primary radiation phase when the lake was first filled, about 1.25 million years ago. They arose from river dwelling ancestors and then filled all available niches in the lake.

Secondary radiations into the many subspecies occurred during the last 200 000 years. Sometime during this period, the water level in the lake fell, resulting in the formation of three separate lake basins. These basins persisted for many thousands of years before the water level rose again.

Figure below shows an outline map of the lake and the location of the three temporary basins caused by lowering of lake levels.

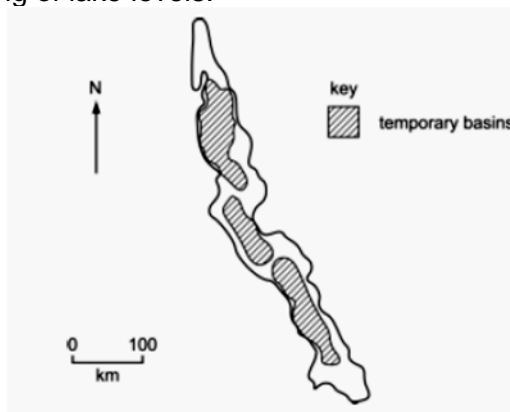

Using Darwin's theory of natural selection, explain how did the six species and subspecies of each species arise on Lake Tanganyika. [10]

- (b) Discuss advantages of using molecular data in determining evolutionary relationships. [3]
- (c) Describe how mitosis ensures genetic stability. [7]

[Total: 20 m]

H1ANDERSON JUNIOR COLLEGE
HIGHER 1

NAME

--

PDG

--	--	--	--

INDEX NUMBER

--	--

BIOLOGY**8875/02**

Paper 2 Core Paper

13 September 2017**Tuesday****2 hours**

Additional Materials: Answer Paper

READ THESE INSTRUCTIONS FIRST

Write your name and PD group on all the work you hand in.

Write in dark blue or black pen.

You may use a soft pencil for any diagrams, graph or rough working.

Do not use paper clips, highlighters, glue or correction fluid.

Section AAnswer **all** questions.**Section B**Answer **all** questions

All working for numerical answers must be shown.

At the end of the examination, fasten all your work securely together.

The number of marks is given in brackets [] at the end of each question or part question.

Calculators may be used

For Examiner's Use	
PAPER 1	
1-30	30 marks
PAPER 2	
<i>Section A</i>	<i>40 marks</i>
1	
2	
3	
<i>Section B</i>	<i>20 marks</i>
5 or 6	
PAPER 2	60 marks
<u>TOTAL</u>	<u>90 marks</u>

Section A

Answer **all** the questions in this section.

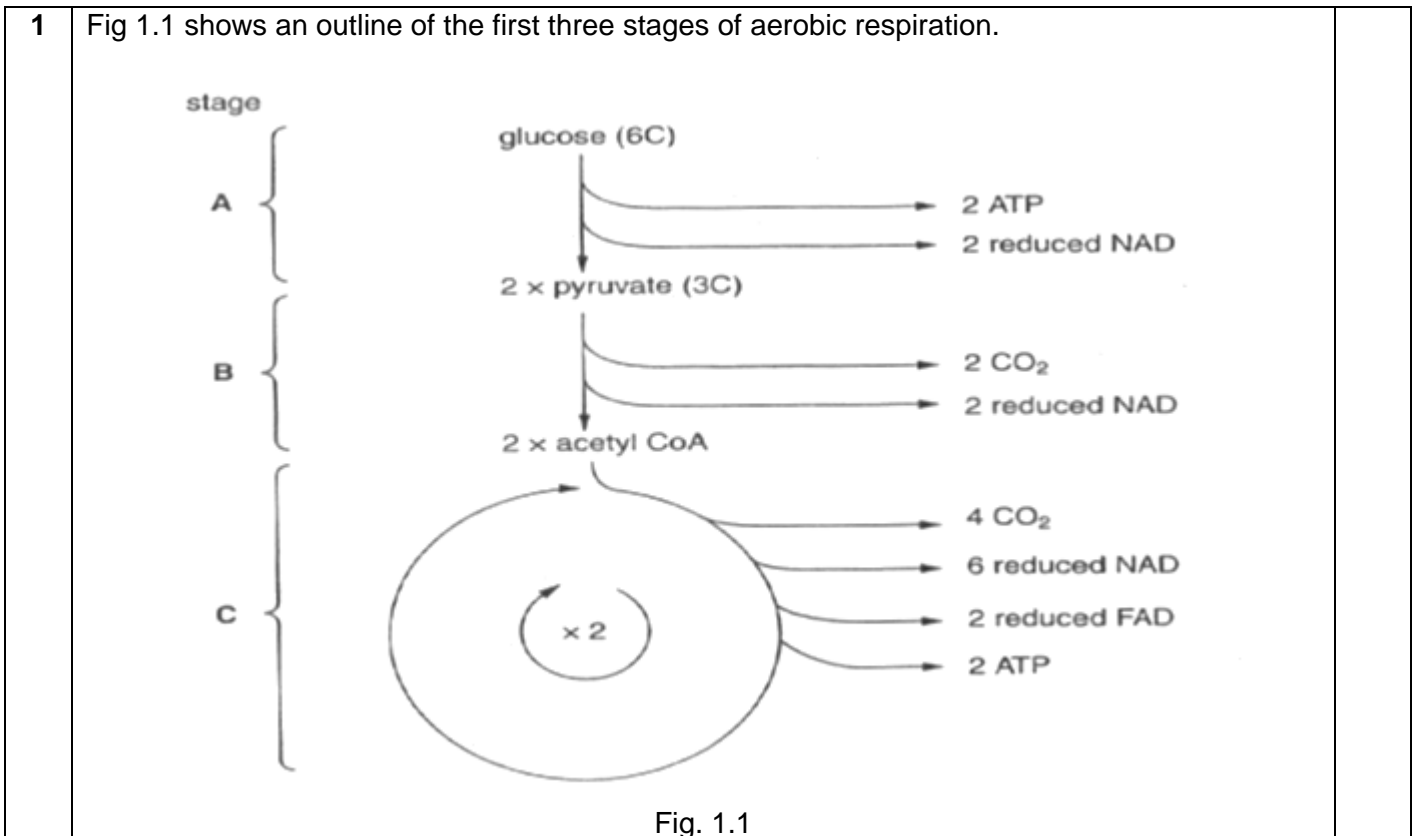

- (a) For each glucose molecule, state the total number of molecules of ATP formed as a result of stages A to B, including any ATP produced through oxidative phosphorylation of the products. Assume that 1 NADP synthesizes 2.5 ATP and 1 FADH₂ synthesizes 1.5 ATP. **Show your working.**

A:

B:

C:

[3]

A: $2 + 2(2.5) = 7$ ATP;
 B: $2(2.5) = 5$ ATP;
 C: $2 + 6(2.5) + 2(1.5) = 20$ ATP;
 Must show working to get 1 m for each stage

- (b) Many enzymes are involved in Krebs cycle. An experiment was carried out to investigate the effect of temperature on respiration. Isolated liver mitochondria were placed in five reaction tubes, with contents and temperature of reaction tube as shown in Table 1 below. The corresponding rates of oxygen uptake were measured. Results are shown in Table 1.

Table 1				
Tubes	Temperature/ °C	Volume of solution added/ cm ³		Rate of oxygen uptake / a.u
		Buffered isolated liver mitochondria	2% pyruvate solution	
1	35	Boiled and cooled	0.01	1.1
2	25	2.00	0.01	7.2
3	35	2.00	0.01	15.1
4	45	2.00	0.01	13.2
5	55	2.00	0.01	1.1

(i)	Enzymes are essential in helping to speed up the rate of metabolic reactions such as those in the Krebs cycle. Explain how enzymes help to speed up rate of reaction.
	<ul style="list-style-type: none"> • Lowers activation energy; • Shape of active site is complementary to substrate; • Ref. to catalytic and contact residues; • Holding substrates in precise orientation; • Causing physical stress in the bonds, making easier for bond breakage/formation; • Provides favourable microenvironment for reaction to take place;
(ii)	Pyruvate has to be used as a substrate for this experiment instead of glucose. Explain why.
	<ul style="list-style-type: none"> • Pyruvate can enter mitochondrion while glucose cannot; • Ref. to pyruvate carrier proteins embedded in mitochondrial membrane but not glucose carrier proteins • Enzymes for glycolysis is not present in mitochondrial only tubes; • glucose cannot be converted to pyruvate for aerobic respiration to occur. <p>Any 2, 2 m</p>
(iii)	With reference to Tubes 2 – 4 from Table 1, account for the effect of temperature on rate of oxygen uptake.
	<ul style="list-style-type: none"> • Ref. to increasing rate of oxygen uptake with temperature + quotation of data with appropriate units; • As temperature increases, increase in kinetic energy of enzyme and substrate; • More effective collision between enzyme and substrate molecules, more enzyme-substrate complexes formed per unit time; • More NADH (and FADH₂) molecules formed per unit time; • More oxygen used as final electron acceptor per unit time;
(iv)	With reference to Table 1, briefly explain the results to Tube 5.
	<ul style="list-style-type: none"> • Ref. to rate of oxygen uptake similar to tube 1 + quotation of data; • Enzymes are denatured, active site configuration is lost and no longer complementary to substrates;

2 Fig. 2.1 shows a part of a pancreatic cell. The pancreas is important in regulating the level of blood glucose in the body by secreting insulin at high blood glucose level.

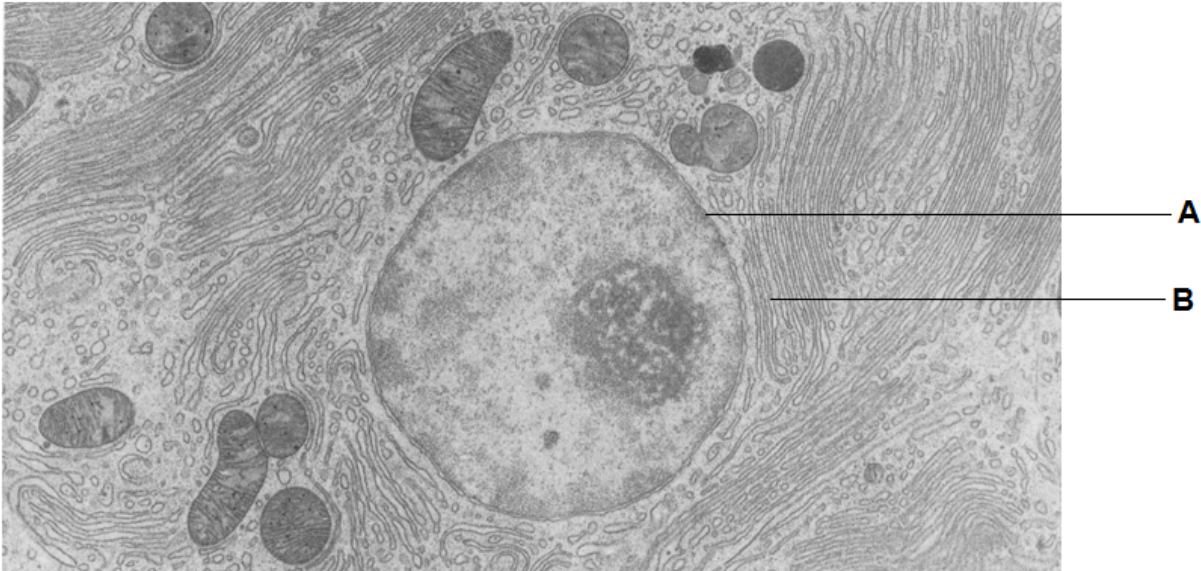

Fig 2.1

(a) (i) State organelle A and B and describe the relationship between the two organelles in a pancreatic cell.

- A: nucleus; B: rough ER;
- Ref. to nucleus containing insulin gene that will be transcribed to insulin mRNA;
- Ref. to nucleus containing nucleolus that transcribes rRNA genes to form ribosomal subunits;
- Ref. to ribosomes embedded on rER;
- Ref. to mRNA from nucleus exported via nuclear pore to cytoplasm;
- Ref. to insulin mRNA being transcribed at ribosomes embedded on rER;

(ii) State one other organelle you can observe in Fig. 2.1 and how it is important to the function of a pancreatic cell.

- Mitochondria;
 - Synthesizes ATP from aerobic respiration for protein synthesis/ AVP;
- Or
- sER;
 - synthesize lipids to replace endomembranal systems such as rER/ GA;

(b) Fig. 2.2 shows a diagrammatic depiction of the process that occurs at organelle B.

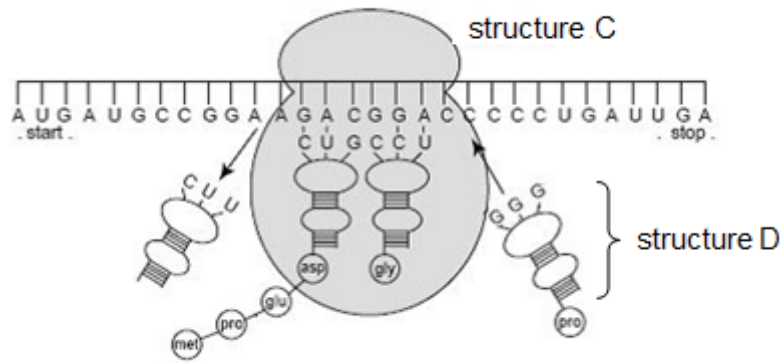

Fig. 2.2

Starting from the position of the ribosome as shown in Fig. 2.2, outline the steps that occur to produce the complete polypeptide.

- Peptidyl transferase catalyses formation of peptide bond between amino acids;
- Ribosome moves along mRNA in 5' to 3' direction / downstream;
- Ref. to amino acids are carried by specific tRNAs to ribosomes / aminoacyl tRNA recruited to ribosome and anticodons complementary base pairs to codon of mRNA;
- Until stop codon reached, release factor binds at A site;
- Covalent ester bond between amino acid and terminal acyl-tRNA hydrolysed, polypeptide released;

(c) **Fig. 2.3A** shows a DNA base sequence. It also shows the effect of two mutations on this base sequence. **Fig. 2.3B** shows DNA triplets that code for different amino acids.

Original DNA base sequence	A	T	T	G	G	C	G	T	G	T	C	T
Mutation 1 DNA base sequence	A	T	T	G	G	A	G	T	G	T	C	T
Mutation 2 DNA base sequence	A	T	T	G	G	C	C	T	G	T	C	T

Fig. 2.3A

DNA triplets	Amino acid
GGT, GGC, GGA, GGG	Gly
GGT, GTA, GTG, GTC	Val
ATC, ATT, ATA	Ile
TCC, TCT, TCA, TCG	Ser
CTC, CTT, CTA, CTG	Leu

Fig. 2.3B

Some mutations affect the amino acid sequences while others do not. Using the information in **Fig. 2.2A** and **Fig. 2.2B** and a feature of the genetic code, explain

		(ii) why mutation 1 has no effect on the protein structure	
		<ul style="list-style-type: none"> genetic code is degenerate; base substitution on the last codon from GGC to GGA encodes for the same amino acid, gly; no change in amino acid sequence, no change in R group interactions, no change in protein folding; 	
		(ii) why mutation 2 could lead to the formation of a non-functional enzyme.	
		<ul style="list-style-type: none"> genetic code is unambiguous; mutation from GTC to CTC changes the amino acid encoded for from val to leu; change in R group interactions, change in protein folding, change in active site configuration; 	
			[Total: 14 m]
3	(a)	State the structural features of DNA that make it a stable molecule.	[2]
		<p>[Any 2]</p> <ol style="list-style-type: none"> complementary bases / base pairing, hold(s) strands together (because of) many hydrogen bonds sugar-phosphate backbone / AW, with covalent / phosphodiester, bonds 	

DNA polymerase is an enzyme involved in the replication of DNA.

One of the substrates required by DNA polymerase is ATP.

ara-ATP is a chemical that affects DNA polymerase activity.

In an investigation, the effect of different concentrations of ATP on the rate of DNA synthesis was determined:

- with no ara-ATP
- with a low concentration of ara-ATP
- with a high concentration of ara-ATP.

The results of the investigation are shown in Fig. 3.1.

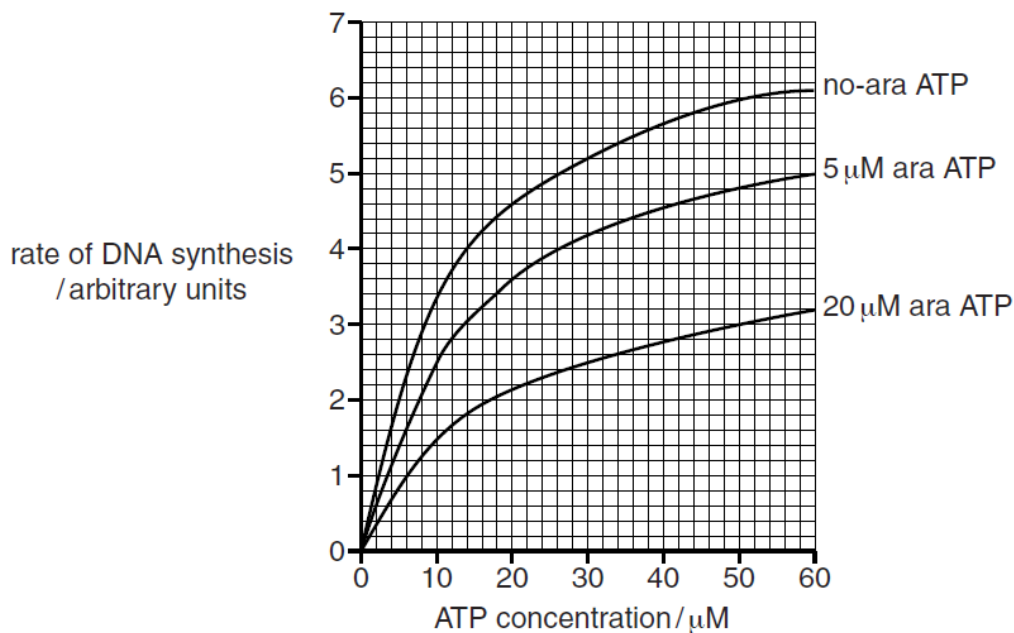

Fig. 3.1

(b) Explain, in terms of mode of action of enzymes, the results of the investigation shown in Fig. 3.1. [4]

1. increasing concentration of ara-ATP (can be comparison between 0 and 5 / 20 or between 5 and 20) decreases enzyme activity, ref. to rate of DNA synthesis for enzyme activity
2. ara-ATP acting as an inhibitor
3. substrate unable to bind with active site / fewer enzyme-substrate complexes (formed)
4. further detail
 - for either *competitive* inhibition e.g. competes with substrate for (binding to) the active site / similar, structure / shape, as substrate or complementary shape to active site
 - OR
 - for *non-competitive inhibition* e.g. binds to site other than active site / changes shape of active site

Colour blindness is a genetic condition characterised by the inability of the brain to perceive certain colours accurately.

- The most common form is termed red-green colour blindness (RGC).
- RGC results from a recessive allele.
- 0.6% of females worldwide have RGC.
- 8.0% of males worldwide have RGC.

The results of the investigation are shown in Fig. 3.2.

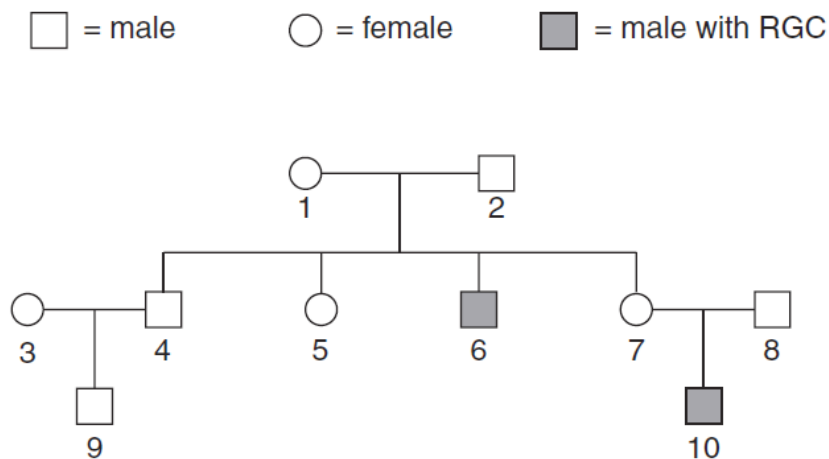

Fig. 3.2

- | | | |
|-----|--|-----|
| (c) | Define the term <i>recessive</i> . | [1] |
| | allele which does not have its effect in heterozygote | |
| (d) | Explain why females are less likely than males to have RGC. | [2] |
| | <ol style="list-style-type: none"> 1. gene / allele, on X chromosome / sex linkage 2. female, needs 2 RGC alleles / homozygous recessive / can be heterozygous 3. male needs only 1 RGC allele to be affected | |
| (e) | With reference to Fig. 3.2, and using the symbols R for the dominant allele and r for the recessive allele, state the genotypes of the individuals 1 and 6 . | [2] |
| | 1 $X^R X^r$ 6 $X^r Y$ | |

[Total: 11 m]

Section B
Answer EITHER 4 OR 5.

Write your answers on the separate answer paper provided.
Your answer should be illustrated by large, clearly labelled diagrams, where appropriate.

Your answers must be in continuous prose, where appropriate.
Your answers must be set out in section (a), (b) etc., as indicated in the question.

4 (a) Describe how gel electrophoresis separates DNA, and explain why it is useful in genetic fingerprint. [10]

Principles

- DNA and loading dye are added into the wells at the cathode/ negative electrode end.
 - A direct current is switched on.
 - DNA is negatively charged due to the phosphate group.
 - Hence it migrates towards the anode/ positive electrode
 - Separation is by size as agarose gel acts as molecular sieve;
 - The larger the mass, the slower it would travel/ found closer to cathode (or vice versa);
 - Buffer solution in which the gel is placed in conducts electricity;
- (Compulsory 5 marks from above) Any 5 below:

Usefulness

- Allows comparison of genetic fingerprints in a **named** case;
- E.g. criminal case, detection of genetic disease, paternity testing
- Each individual has a unique genetic fingerprint;
- As each individual has alleles that give rise to the bands/ reference to bands obtained after DNA is cut with restriction enzyme;
- Similarity between genetic fingerprint implies inheritance of genes/ genetic similarity/ genetically related;
- Reference to DNA ladder to allow estimation of band size.
- Award 1 mark for an annotated diagram to illustrate;

(b) Describe the features of zygotic stem cells and embryonic stem cells that distinguish them from each other. [3]

Feature	Zygotic Stem Cell	Embryonic Stem Cell
Potential to give rise to cell types	Totipotent -have the capacity to give rise to all cell type of the body and to form an entire organism	Pluripotent - capable of generating all cell types of the body except extra-embryonic tissues e.g. the amnion, chorion, and other components of the placenta.
Normal Function	divide by mitosis to form a compact ball of cells known as morula, which further divides to form a blastocyst. The blastocyst eventually develops into a growing foetus.	differentiate into cells of different cell types, tissues and organs in a developing foetus . Specifically, it first gives rise to cells that form the three embryonic germ layers – endoderm, mesoderm and ectoderm.
Formation process	Formed by union of sperm and egg	Formed from differentiation of zygotic stem cell
Location	Found within zygote	Found within embryo/ blastocyst
Therapeutic use	None (Ethical concerns)	Embryonic stem cells induced to differentiate to specialised cells such as nerve cells for Parkinsons or heart muscle

		cells for heart disease.	
		Also ethical concerns. Possible solution – iPSC and cybrids.	

(c) Discuss the ethical implications of genetically modifying plants.

[7]

- Bt corn, Golden Rice and GM Salmon have the capability of producing more yield with a given number of resources, as compared to traditional methods. Allow for more people to be fed with a given amount of resources.
- Bt corn, Golden Rice and GM Salmon have the capability of producing more yield with a given number of resources, as compared to traditional methods. Helps to cut down cost of production.
- Bt corn has the capability of producing better quality crops as the crystallized protein has an insecticidal effect.
- Mixing genes among species may be argued to be creating a new 'species' through artificial means.
- There is a risk of the genetically modified organism escaping and its effect on the environment and biodiversity is unknown.
- The effects of GM products on human health are still not fully known The effects may only be known after a long period of exposure.
- There is no law making it mandatory for GM food to be labelled.
Allergic reactions may occur if people unknowingly consume products containing introduced genes.

OR

- 5 (a) In Lake Tanganyika in Africa, there are six species of fish of the genus *Tropheus* and a much larger number of distinctly coloured subspecies of each of the six species. *Tropheus* species are small fish that are confined to isolated rocky habitats around the shores of Lake Tanganyika.
- The six species evolved during the primary radiation phase when the lake was first filled, about 1.25 million years ago. They arose from river dwelling ancestors and then filled all available niches in the lake.
- Secondary radiations into the many subspecies occurred during the last 200 000 years. Sometime during this period, the water level in the lake fell, resulting in the formation of three separate lake basins. These basins persisted for many thousands of years before the water level rose again.
- Fig. 5.1** shows an outline map of the lake and the location of the three temporary basins caused by lowering of lake levels.

[10]

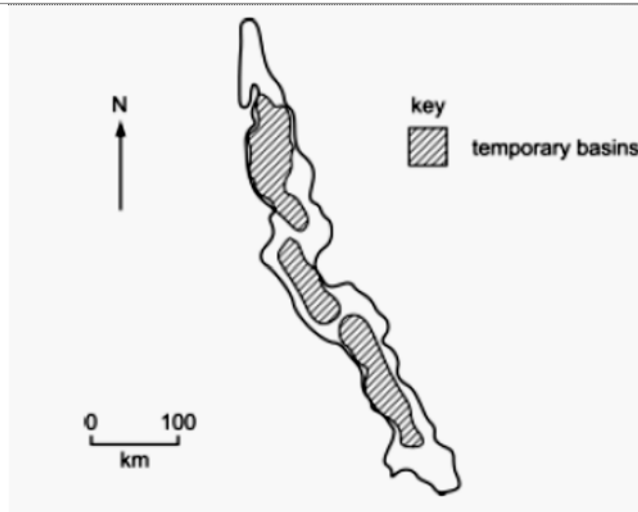

Using Darwin's theory of natural selection, explain how did the six species and subspecies of each species arise on Lake Tanganyika.

- Mutations/ different alleles in the genetic sequence of population of fish;
- Genetic variation leads to phenotypic variation in the population of fish;
- Different parts of the shore/rocky habitat exerts different selection pressure;
- Phenotypes that have selective advantage are selected for, go on to survive, reproduce and pass down favourable alleles/ converse argument;;
- Overtime, allele frequency of population changes;
- Fish with advantageous traits increase in population;
- Genetic drift event occurs independently in different parts of the shores;
- Gene pool between population of fish diverges;
- Population of fish becomes reproductively isolated;
- Because of habitat differentiation/ behavioural isolation/ avp;
- No gene flow;
- Do not interbreed to produce viable and fertile offsprings, forming six species of fish;
- Formation of 3 temporary basins resulted in geographical isolation;
- Ref. to different environment and selection pressure in the 3 basins;
- No gene flow between species of fish in the 3 basins, many subspecies arise;

(b) Discuss advantages of using molecular data in determining evolutionary relationships.

[3]

- Analysis of molecular data is objective since differences in DNA/RNA/ proteins can be objectively compared by analyzing nucleotide and amino acid sequences.
- Data obtained from sequence comparisons are quantitative and can be used to measure degree of relatedness between different organisms based on calibrated molecular clocks, the number of nucleotide/amino acid
- differences can be used to estimate the time of divergence between two closely related species
- Molecular methods are able to differentiate two organisms with similar morphologies/ convergent evolution based on molecular differences.
- Molecular methods are also useful for studying evolutionary relationships between groups of organisms that have very little common ground for morphological comparison e.g. mammals and bacteria
- All known life forms can be compared since all organisms possess nucleic acids as the genetic material.

- Scientists are able to use both living and dead specimen material in classification of organisms.
- Molecular methods also reveal that some major phenotypic differences may actually be due to small genetic differences

Any 3

(c) Describe how mitosis ensures genetic stability.

[7]

- Definition of genetic stability: Genetical stability means daughter cells have the same number of chromosomes and same genes as the parent cells.
- (Compulsory one mark for first point) Any 6 below:
- At prophase, each chromosome comprises of genetically identical sister chromatids joined at centromere.
 - No crossing-over at prophase ensures that the chromatids are genetically identical.
 - Due to semi-conservative replication of DNA during S phase of interphase earlier before mitosis.
 - At metaphase, chromosomes align singly along equator.
 - Correct attachment of spindle fibres during metaphase ensure no non-disjunction later.
 - At anaphase, centromere of each chromosome divides.
- To consider following marking points?
- Genetically identical sister chromatids separate to form genetically identical chromosomes.
 - Spindle fibres pull equal number of chromosomes to each pole.
 - Cytokinesis (separation of cytoplasm) during telophase ensures two genetically identical daughter cells.
 - Mitosis forms 2 nuclei/ cells with **same number of chromosomes** as the parent cells/ has **complete set of genome**;
 - During prophase, chromatin fibres (fully) condense into discrete chromosomes to ensure that **even distribution** of the genetic material is **manageable**;
 - Chromosomes appear as double arm structures with **genetically identical** sister chromatids join at the centromeres;
 - The sister chromatids are genetically identical with **same base sequences, same alleles of genes**;
 - The sister chromatids are products of **semi-conservative** DNA replication that took place in **S phase of interphase** before mitosis begin;
 - During prophase, the nuclear envelope disintegrates/ break down to allow for the attachment of kinetochore microtubules to the centromeres of the chromosomes;
 - During prophase, **homologous chromosomes do not pair up** and thus **no crossing over** occurs, that allow sister chromatids to remain genetically identical throughout mitosis;
 - All the chromosomes lined up singly at the metaphase plate during metaphase; they do not pair up and orientation of each chromosome does not affect the gene sequence each daughter cell receives because the sister chromatids are genetically identical/ each pole will receive one DNA molecule of each chromosome;
 - Microtubules attached to a particular chromatid all comes from one pole of spindle and those attached to its other sister chromatids come from the opposite pole ensures each pole will receive one DNA molecule of each chromosome/ Centrioles migrate to opposite poles of the cells and organises spindle fibers that attach to each chromosomes at the centromere via kinetochores to ensure one complete set of genetic material is pulled to opposite poles;
 - During telophase, chromosomes decondense to form chromatin and nuclear envelope reforms around each set of chromosomes at opposite poles of the cell, forming 2 nucleus containing identical genetic information;
 - During cytokinesis, cell membrane undergoes cleavage to form 2 genetically identical daughter cells

