

SINGAPORE CHINESE GIRLS' SCHOOL

FIRST SEMESTRAL ASSESSMENT 2015

SCIENCE

PRIMARY FIVE

NAME: _____ ()

DATE: _____

CLASS: PRIMARY 5 SY /

BOOKLET A

30 questions

60 marks

Total time for Booklets A & B: 1 h 45 min

DO NOT OPEN THIS BOOKLET UNTIL YOU ARE TOLD TO DO SO.

FOLLOW ALL INSTRUCTIONS CAREFULLY.

Part I (60 marks)

For each question from 1 to 30, 4 options are given.

One of them is the correct answer. Make your choice, (1, 2, 3 or 4).

Shade the correct oval (1, 2, 3 or 4) on the Optical Answer Sheet.

1. Josephine carried out the following experiment on a plant. She placed a lighted lamp near the opening of an opaque box for a week and recorded the following observations.

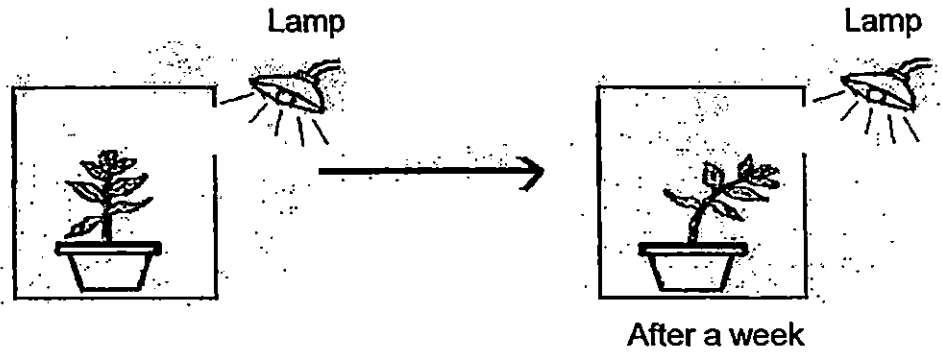

She then placed the lighted lamp on the left side of the plant for another week and recorded the following observation.

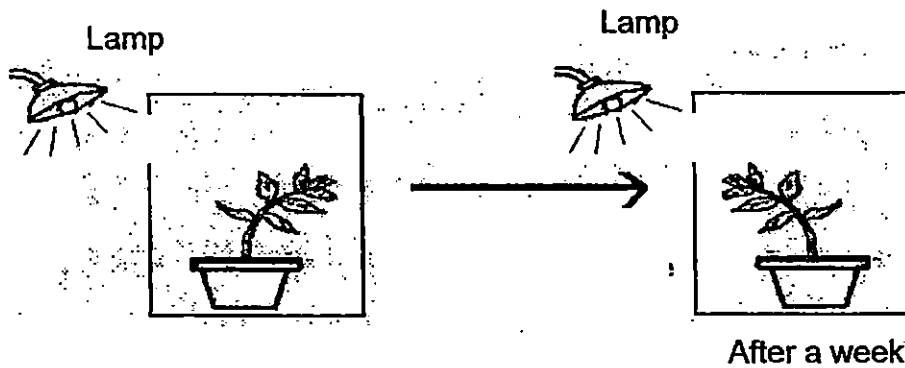

Which characteristics of plants were Josephine trying to show in this experiment?

Plants _____.

A: need water

B: respond to changes around them

C: grow towards the direction of light

D: make food in the presence of light

(1) A and B only

(2) A and D only

(3) B and C only

(4) B, C and D only

2. Johnny and his friends conducted an experiment using bread to test how mould would grow in different conditions.

	Temperature	Moisture on bread
Amy's bread	5 °C	High
Delvi's bread	30°C	Low
Muthu's bread	5°C	Low
Johnny's bread	30°C	High

Whose bread would contain the least amount of mould after 1 week?

- (1) Amy's
(2) Delvi's
(3) Muthu's
(4) Johnny's

3. Xiao Hui wanted to make a grocery bag for her mother. She collected 4 unknown materials, A, B, C and D from her friends. She noted their properties in the table below.

Properties	A	B	C	D
Is it strong?	No	Yes	No	Yes
Is it waterproof?	No	Yes	Yes	No
Is it transparent?	Yes	No	No	Yes
Is it light in weight?	Yes	Yes	Yes	No

Which is the most suitable material for Xiao Hui to make the bag?

- (1) A
(2) B ✓
(3) C
(4) D

4. Look at the flow chart below:

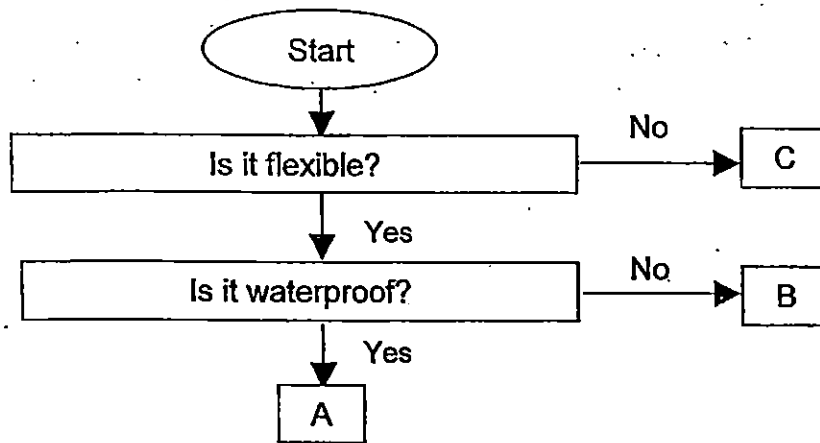

Which one of the following groups of materials fit the descriptions of the Materials A, B and C above?

	A	B	C
(1)	Plastic	Paper	Rubber
(2)	Ceramic	Glass	Plastic
(3)	Paper	Plastic	Ceramic
(4)	Rubber	Paper	Glass

5.



Seal



Rabbit



Tiger

Based on what you know about the animals above, in what ways are they similar?

They _____.

- (1) have feathers
- (2) can only live on land
- (3) breathe using their lungs
- (4) reproduce by laying eggs

6. The arrows below show how blood flows in our human body.

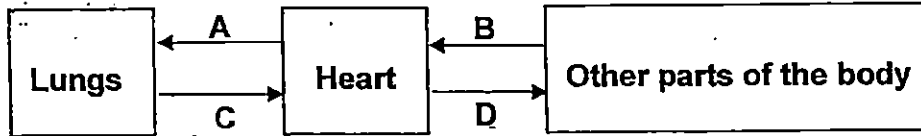

Based on the diagram above, which of the following statements are correct?

- P: The blood at A contains less oxygen than the blood at C.
- Q: The blood at A contains more oxygen than the blood at D.
- R: The blood at B contains less carbon dioxide than the blood at C.
- S: The blood at B contains more carbon dioxide than the blood at D.

- (1) P and R only
- (2) P and S only
- (3) Q and R only
- (4) Q and S only

7. Like a cell, a shopping mall is made up of different parts performing different functions. The text below describes Mall Y.

Mall Y specialises in selling electronic goods. The head office controls the sales of the goods sold. The security post at the entrance controls the flow of customers. A cafe at the basement provides food to customers.

Based on the description above, which one of the following matches the functions of the parts of Mall Y to the cell parts correctly?

	Head office	Security post	Cafe
(1)	Nucleus	Cell wall	Cytoplasm
(2)	Nucleus	Cell membrane	Chloroplast
(3)	Cell membrane	Cell wall	Chloroplast
(4)	Cell wall	Nucleus	Cytoplasm

8. Justin made a few statements about inhaled and exhaled air as shown below.

- A: Exhaled air is warmer than inhaled air.
- B: Exhaled air contains more dust than inhaled air.
- C: Inhaled air contains more oxygen than exhaled air.
- D: Inhaled air contains more water vapour than exhaled air.

Which of the statement(s) is/are correct?

- (1) A only
- (2) A and C only
- (3) B and D only
- (4) A, B and D only

9. Which 2 systems work together to ensure that carbon dioxide is removed from body cells efficiently?

- A: Digestive
- B: Circulatory
- C: Reproductive
- D: Respiratory

- (1) A and B
- (2) A and D
- (3) C and D
- (4) B and D

10. Zoe made a comparison between the Human Circulatory System and the Plant Transport System in the table below. Which of the comparisons was correct?

	Human Circulatory System	Plant Transport System
(1)	Oxygen is taken in only through the nose.	Oxygen is taken in through the stomata.
(2)	Different tubes transport all the different substances round the body.	One main tube transports all the different substances.
(3)	Water enters the body through the nose and mouth.	Water enters the plant through the leaves.
(4)	A heart is required to pump substances round the body.	No organ is needed to pump materials through the tubes.

11. Donovan has a fish tank at home. He wants to compare how different organisms take in the air needed for survival. Which of the following shows how the organisms in the tank take in the air needed for survival?

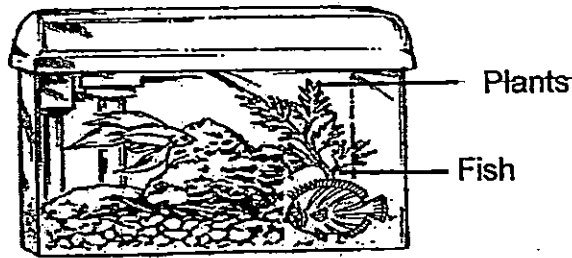

	Plants	Fish
(1)	Roots	Gills
(2)	Roots	Lungs
(3)	Stomata	Gills
(4)	Stomata	Lungs

12. Which of the following diagrams shows the correct path taken by the food made by the plant?

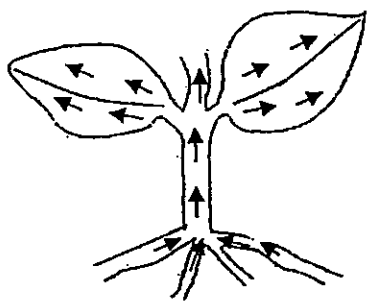

(1)

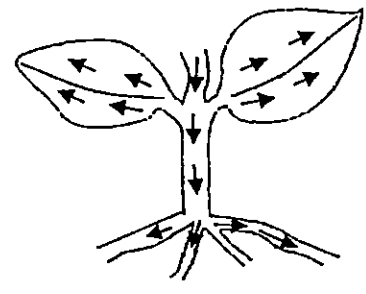

(2)

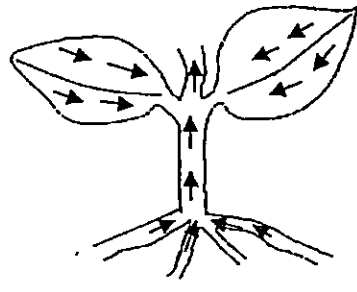

(3)

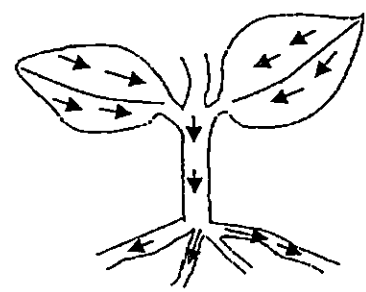

(4)

13. The shaded part below shows the location of the water-carrying tubes in the plant.

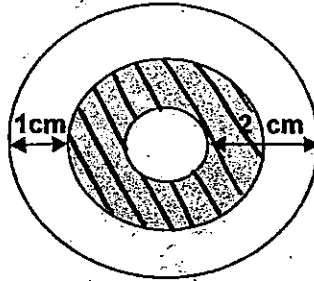

Aunty Julie made 2 different cuts at A and B on the stem of her plant, as shown in the diagram below. She observed that leaves P died while leaves Q were still healthy.

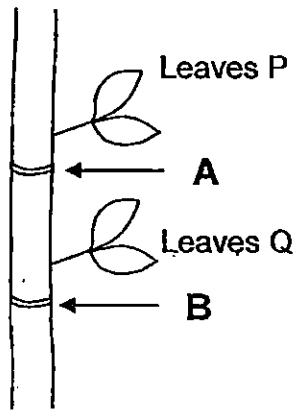

Which one of the following shows the correct depth of cut at A and B?

	Depth of cut at A (cm)	Depth of cut at B (cm)
(1)	1	1
(2)	1	2
(3)	2	1
(4)	2	2

14. Feng Hui wants to find out the poles of 3 ring magnets. She placed them through a wooden rod and recorded her observation as shown below.

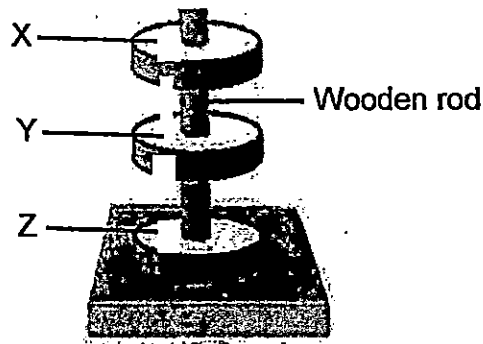

Which of the following shows the possible identity of poles X, Y and Z?

	X	Y	Z
(1)	North pole	North pole	North pole
(2)	North pole	South pole	North pole
(3)	South pole	North pole	North pole
(4)	South pole	South pole	North pole

15. Kimmie wanted to make an electromagnet. She coiled an electrical wire 5 times around an iron nail. She connected the ends of the wires to a battery.

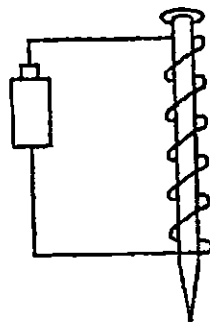

She found out that only a few paper clips can be attracted by the magnetised iron nail. What should she do to make a stronger electromagnet?

- A: Use longer wires.
- B: Use two batteries.
- C: Use aluminium foil instead of the iron nail.
- D: Increase the number of coils around the nail.

- (1) A and B only
- (2) A and C only
- (3) B and D only
- (4) B, C and D only

16. Rosie hung 4 bars A, B, C and D, from a piece of rod. They moved in different directions as shown in the diagram below.

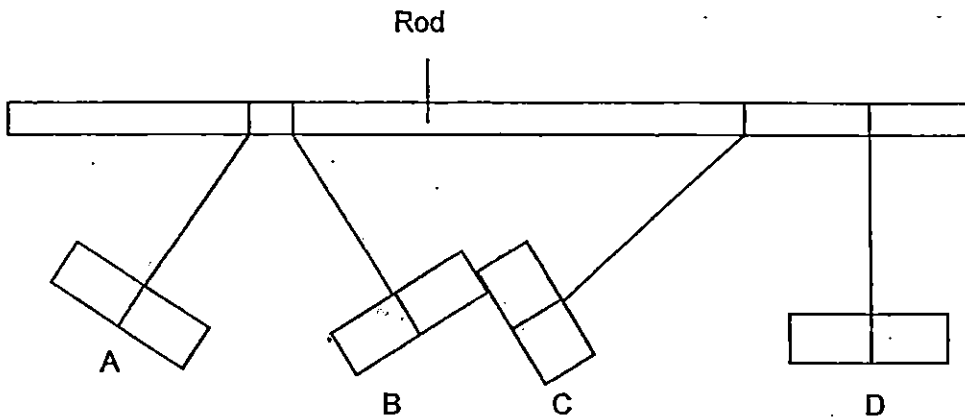

Which of the following shows the possible identity of the 4 bars?

	A	B	C	D
(1)	Plastic	Steel	Aluminium	Magnet
(2)	Magnet	Magnet	Steel	Plastic
(3)	Steel	Magnet	Magnet	Aluminium
(4)	Magnet	Steel	Steel	Plastic

17. The diagram below shows the different stages in a life cycle.

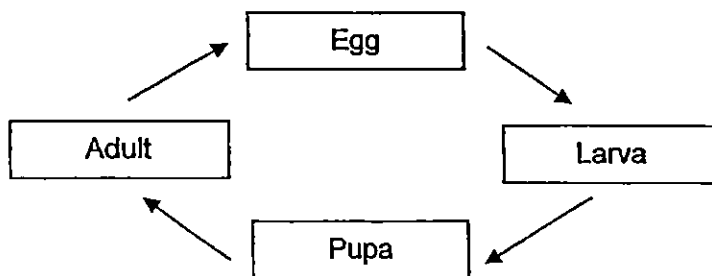

Which 2 animals go through the life cycle as shown above?

- (1) Cockroach, Housefly
- (2) Housefly, Dragonfly
- (3) Butterfly, Grasshopper
- (4) Mealworm beetle, Mosquito

18. The diagram below shows the members of Benny's family who carry the genetic trait for Disease X.

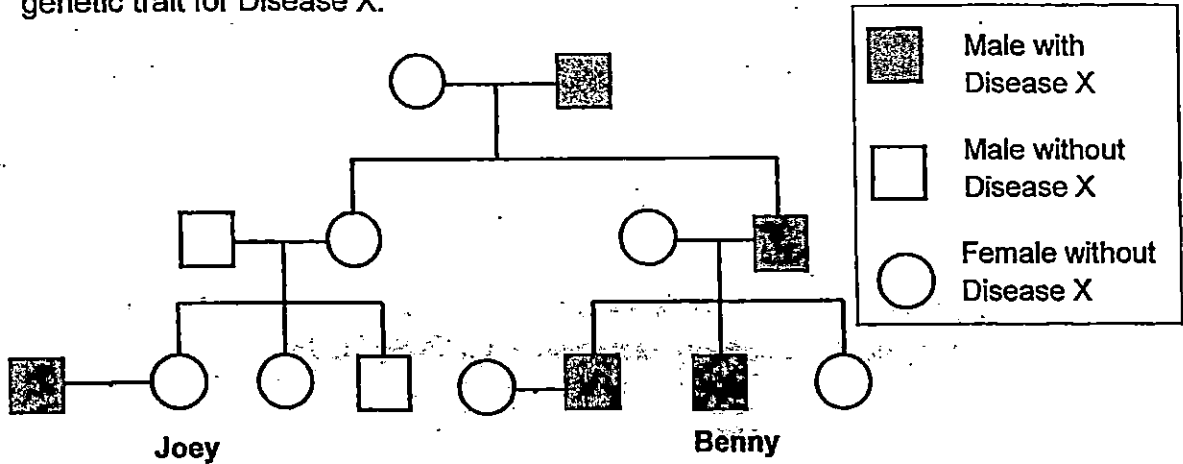

Based on the information above, which of the following statements can be concluded?

- A: Only males will have Disease X.
- B: Benny inherited the genes of Disease X from his father.
- C: Parents without Disease X will not produce a young with Disease X.

- (1) A only
- (2) B only
- (3) B and C only
- (4) A, B and C

19. Which of the following students are correct?

Seth	Flowers appear before the fruits.
Janice	All plants reproduce from seeds.
Kumar	Seeds can germinate in the dark.
Beatrice	Plants must be fertilised before pollination can take place.

- (1) Seth and Kumar
- (2) Janice and Kumar
- (3) Seth and Beatrice
- (4) Janice and Beatrice

20. The following diagram shows parts of a flower.

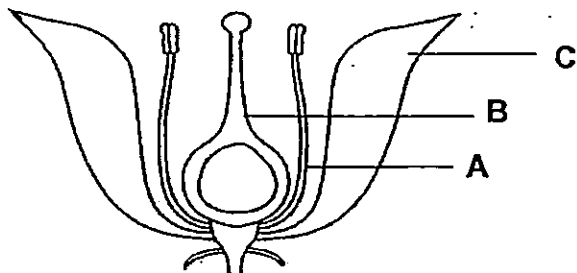

Mrs Fang has 4 identical flowers of the above (F, G, H and K). She removed some parts of the flowers as shown in the table below.

Flower	Parts removed
F	A
G	C
H	A and B
K	B and C

Which of the flowers are still able to undergo fertilisation?

- (1) Flower G
- (2) Flowers F and G
- (3) Flowers H and K
- (4) Flowers F, G and K

21. Look at the diagram below.

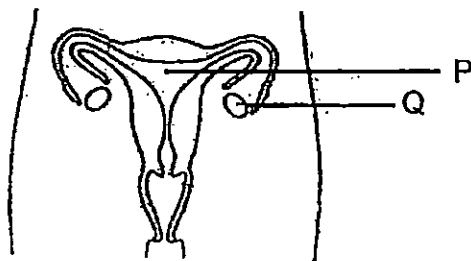

Which one of the following statements about the human reproductive system is true?

- (1) Foetus develops at P.
- (2) Foetus develops at Q.
- (3) Sperm is produced at P.
- (4) Sperm is produced at Q.

22. Mr Ganesan wanted to refill his empty shampoo bottle with a refill pack, using a funnel. After some time, he observed that the shampoo stopped flowing into the bottle, as shown in the diagram below.

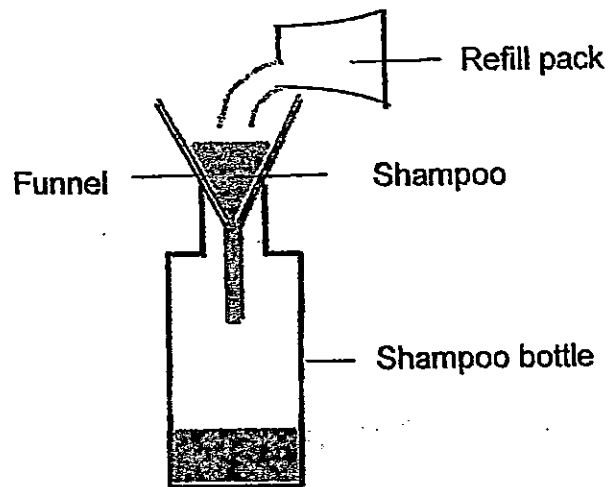

Which one of the following statements explains Mr Ganesan's observation?

- (1) Air has mass.
- (2) Air occupies space.
- (3) The shampoo has mass.
- (4) The shampoo bottle has a definite volume

23. How are carbon dioxide and ice similar?

- A: They have mass.
- B: They take up space.
- C: They can be compressed.
- D: They have definite shape.
- E: They have a definite volume.

- (1) A and B only
- (2) B and C only

- (3) C and D only
- (4) B, C and E only

24. Jenny poured some water and oil into Beaker P and placed some marbles into Beaker Q. She then poured the contents in Beaker P into Beaker Q.

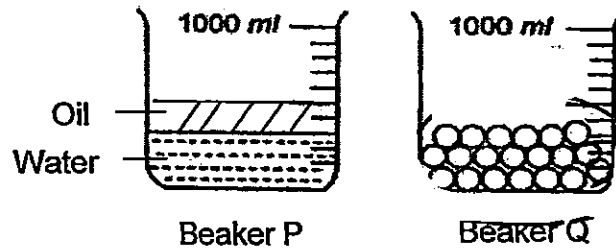

Which of the following diagrams best shows the water level in Beaker Q?

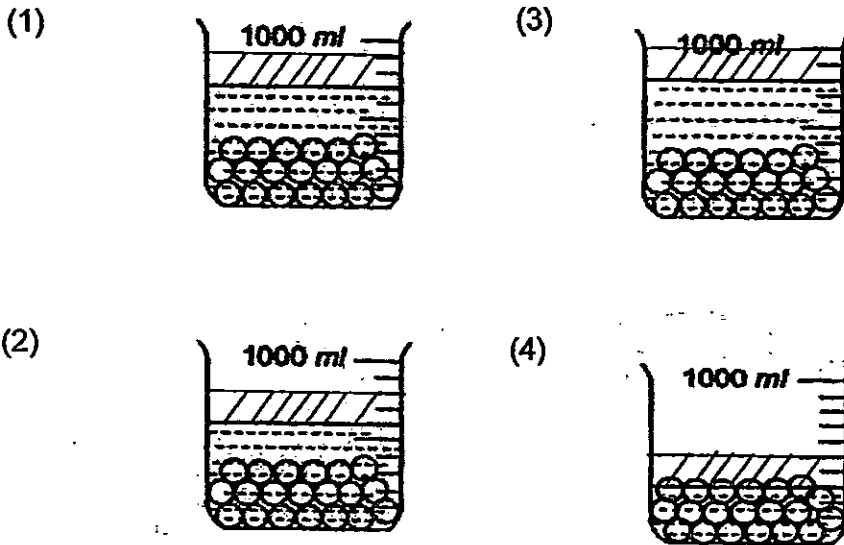

25. The table below shows the melting points and boiling points of 3 substances, A, B and C.

Substances	Melting Point ($^{\circ}\text{C}$)	Boiling Point ($^{\circ}\text{C}$)
A	35	200
B	15	30
C	60	120

Which one of the following observations is definitely correct when the temperature of the substances is 45°C ?

- (1) Substance A is a gas.
- (2) Substance B is a liquid.
- (3) Substance C is a solid.
- (4) Substance A and C are liquids

26. The diagram below shows a change in the state of water.



Which one of the following processes best represents the above change in water?

- (1) Melting
 - (2) Freezing
 - (3) Evaporation
 - (4) Condensation
27. Hannah filled 2 beakers, F and G, with different amount of water and heated them up to 100°C .

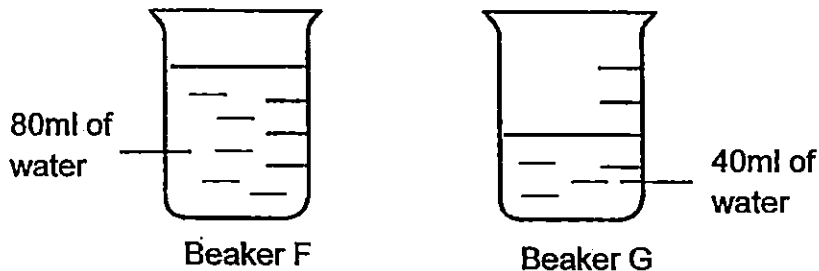

Which of the following statements is true about the 2 beakers of water?

- (1) The water in Beaker F is hotter than that in Beaker G.
- (2) The water in Beaker F has more heat energy than Beaker G.
- (3) The water in Beaker G has more heat energy than Beaker F.
- (4) The water in both beakers has the same amount of heat energy.

28. Serena wears the helmet below whenever she cycles at night. The reflector strips help motorists to see Serena.

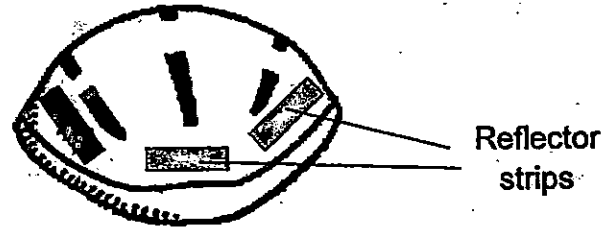

Which material works best as the reflector strips?

Amount of light detected

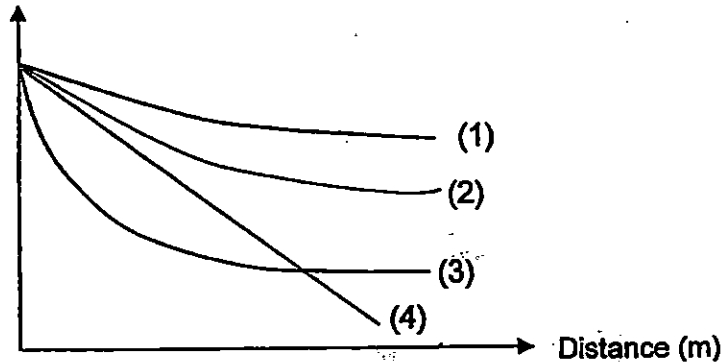

29. Jasmine shone the torch at different angles on object G.

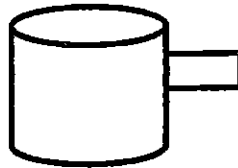

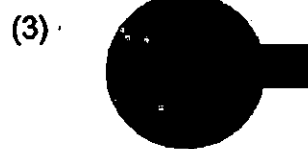
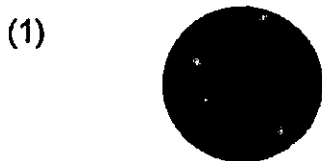

Object G

Which of the following shadows would not be a possible shadow formed by Object G?



30. The table below shows the expansion of certain metals when heated to 100°C.

Key	Metal	Length of metal at room temperature	Length of metal at 100°C
	W	100 mm	102 mm
	X	100 mm	108 mm
	Y	100 mm	105 mm

Metals W, X and Y were used to make rings as shown below. The rings were immersed into water at 100°C for 10 minutes. Which of the inner rings could be easily removed after 10 minutes?

A:

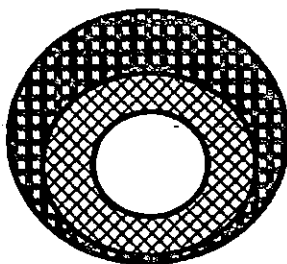

C:

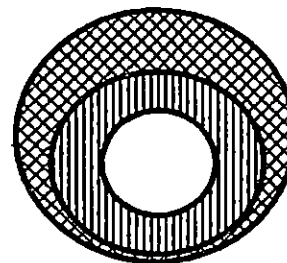

B:

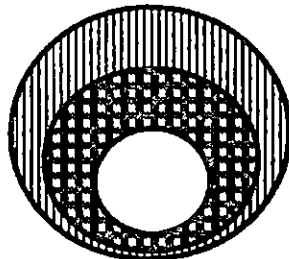

D:

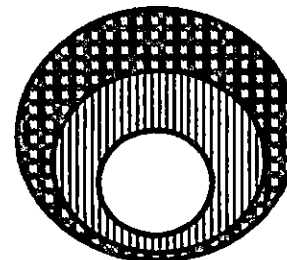

(1) A and B only

(3) B and D only

(2) A and C only

(4) C and D only

SINGAPORE CHINESE GIRLS' SCHOOL
FIRST SEMESTRAL ASSESSMENT 2015

SCIENCE
PRIMARY FIVE

NAME: _____ ()

DATE: _____

CLASS: PRIMARY 5 SY

Booklet A		60
Booklet B		40
Total		100

Parent's Signature _____

BOOKLET B

14 questions

40 marks

Total time for Booklets A & B: 1 h 45 min

DO NOT OPEN THIS BOOKLET UNTIL YOU ARE TOLD TO DO SO.

FOLLOW ALL INSTRUCTIONS CAREFULLY.

Part II (40 marks)

Answer all the following questions.

31. Observe the following flowchart carefully.

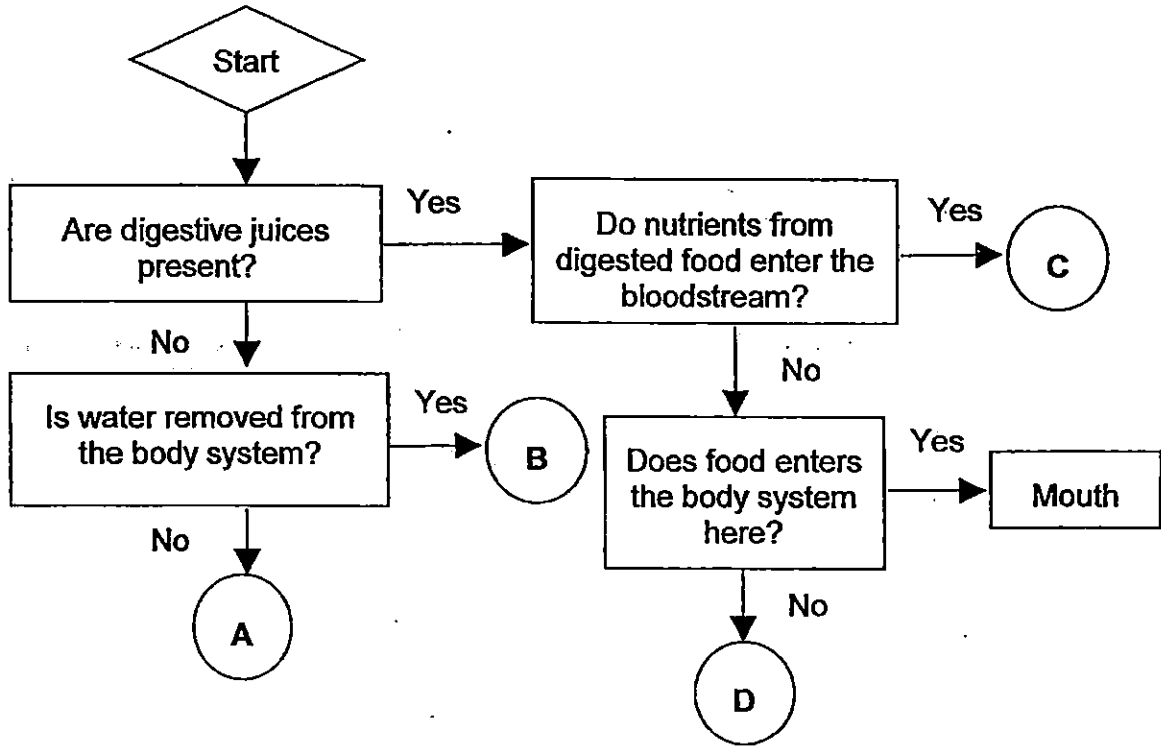

In the flowchart above, the parts 'A', 'B', 'C' and 'D' represent parts of the human digestive system. Identify the 4 parts of the digestive system. (2m)

(a) A: _____

(b) B: _____

(c) C: _____

(d) D: _____

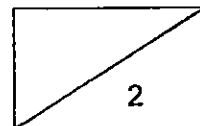

32. Jane observed 2 types of cells under the microscope and recorded her results in the table below.

	Cell A	Cell B
Nucleus	Yes	Yes
Cell Wall	No	Yes
Chloroplast	No	No
Cell Membrane	Yes	No
Cytoplasm	Yes	Yes

(a) Jane's teacher told her that she might have made a mistake in her observation. Which cell, A or B, is likely to have the wrong observation? Explain your answer. (1m)

(b) Jane also observed another type of cells under the microscope.



Are the cells above animal or plant cells? Explain your answer. (1m)

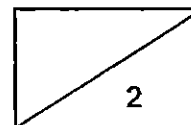

33. Dorothy drew and labelled the different parts of the human respiratory system as shown in the diagram below.

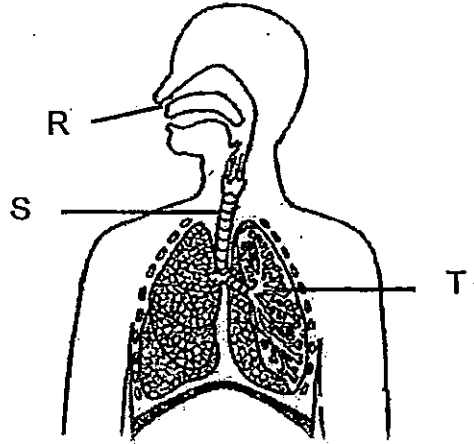

She made the following statements. Put a tick (✓) in the correct boxes. (4m)

	Statement	True	False
(a)	Part R is the only part that allows air in and out of the body.		
(b)	Oxygen is absorbed by the blood at Part S.		
(c)	Only oxygen can pass through Part S.		
(d)	Carbon dioxide is removed from the blood at Part T.		

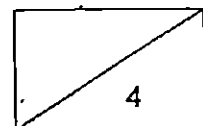

34. Ahmad wanted to find out if the amount of oxygen in a tank affects the number of guppies swimming near the surface of the water. He placed an equal number of similar guppies into tanks A, B, C and D, followed by the adding of different amounts of oxygen in each tank.

After one day, he recorded his observations in the table shown below.

	A	B	C	D
Amount of oxygen in the water (cm^3)	2	13	7	5
Number of guppies near the water surface	10	2	6	8

- (a) State the relationship between the amount of oxygen in the water and the number of guppies near the water surface? (1m)

- (b) Explain why all the guppies in tank A died after a few days. (1m)

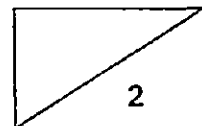

35. Mrs Daisy set up the experiment below to find out more about the function of stomata. Using 3 leaves from the same plant, she painted the top and bottom of leaf P and only the top surface of leaf Q with black paint. She left leaf R unpainted. She then wrapped each leaf with a clear plastic bag and placed the pot under the sun.

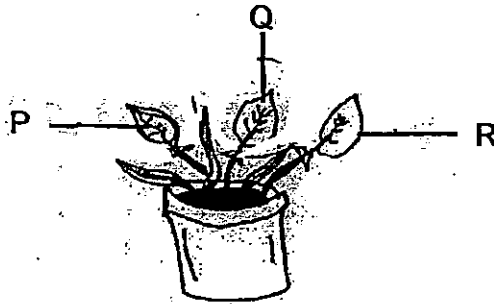

- (a) Mrs Daisy observed water droplets inside the plastic bags after 2 hours. In which of the bag(s)/leaf(s) did she observe the water droplets? Explain your answer. (2m)

- (b)

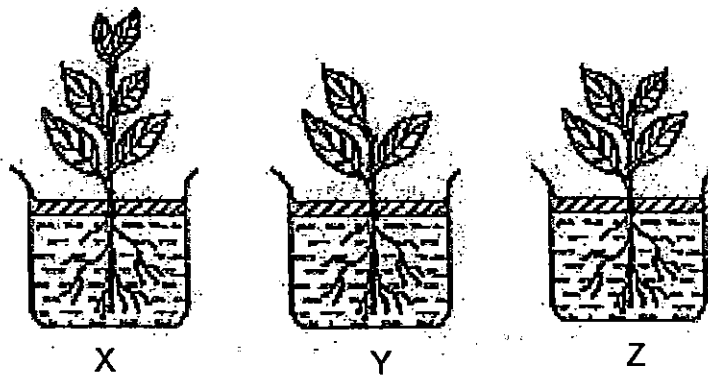

Mrs Daisy conducted another experiment as shown above. At the end of 5 days, all the beakers have less water. Order the beakers starting from the one with the most water left to the one with the least water left. (1m)

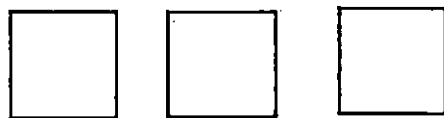

Most
→
 Least

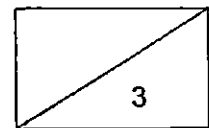

36. Darryl wanted his toy train to move on its own. He tied Object E at the back of the train, as shown in the diagram below. When Object F was placed near the toy train, the train moved away from Object F.

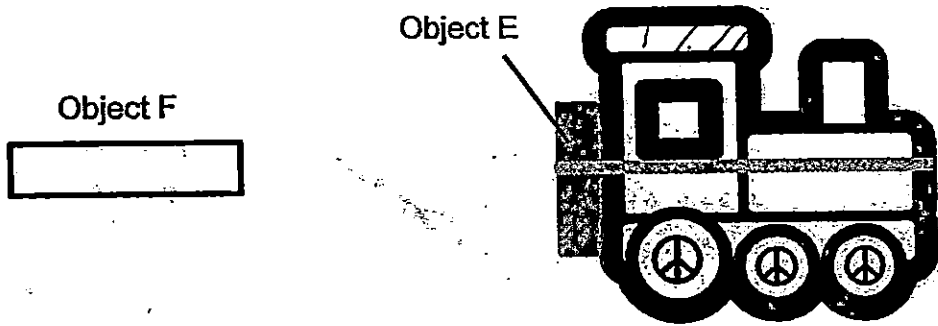

- (a) What is Object E? (1m)

- (b) Explain why the toy train move away from Object F when Object F was placed near it. (1m)

- (c) Darryl then made the following structure using 1 horseshoe magnet and 3 bar-magnets. Fill in the blanks with 'N' for N-pole and 'S' for S-pole. (1m)

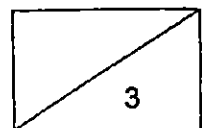
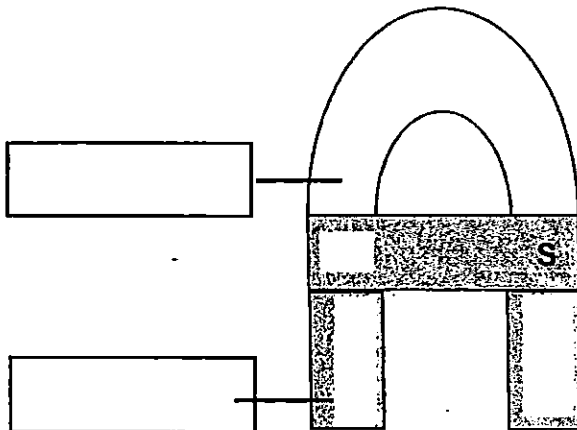

37. The graph below shows the mass of a seedling and its seed leaves measured over a period of time.

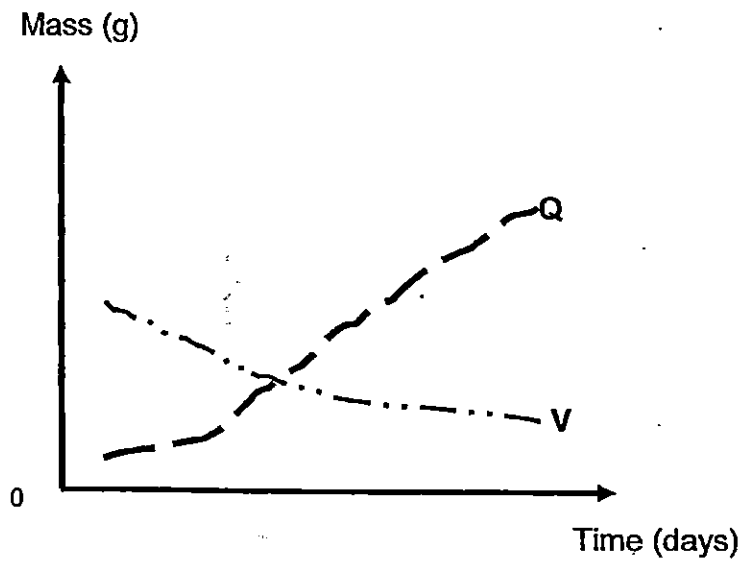

(a) Which graph, Q or V, represents the seedling? (1m)

(b) Which graph, Q or V, represents the seed leaves? (1m)

(c) Explain why the mass of V decreases over a period of time. (1m)

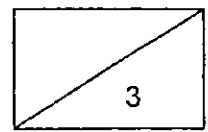

38. Gurma found 2 types of plants in a field and recorded her observations in the table below.

	Leaves	Stems	Flower	Fruits/ seeds
Plant 1	Small	Long	Small and coloured	Pod-like. Turns brown and dry when ripe.
Plant 2	Long and thin	Thick and long	Has white, feather-like stigmas	Has a fibrous husk

(a) Based on her observations above, state the method of seed dispersal of Plant 1 and Plant 2. (2m)

Plant 1 : _____

Plant 2 : _____

(b) The diagram below shows the locations of Plant 3 in an area. X shows the parent plant and W shows the young plants.

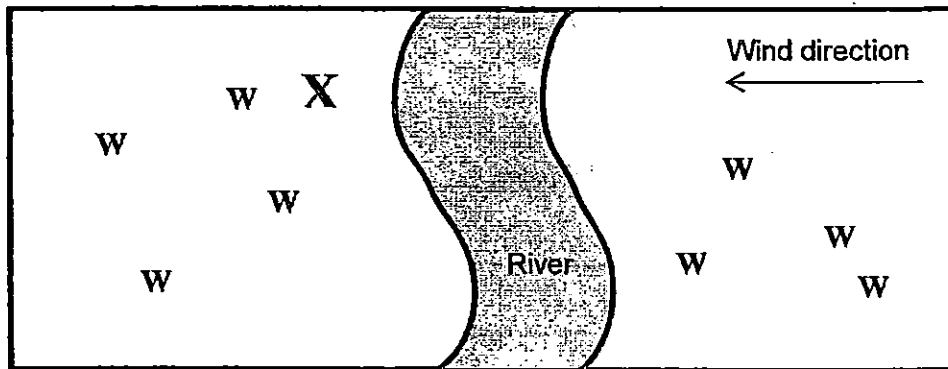

Give 2 possible characteristics of the fruits/seeds of Plant 3. (1m)

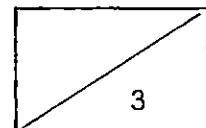

39. A beaker containing Substance W was heated continuously from Point E to Point K. The temperature of substance W was recorded and plotted on the graph below.

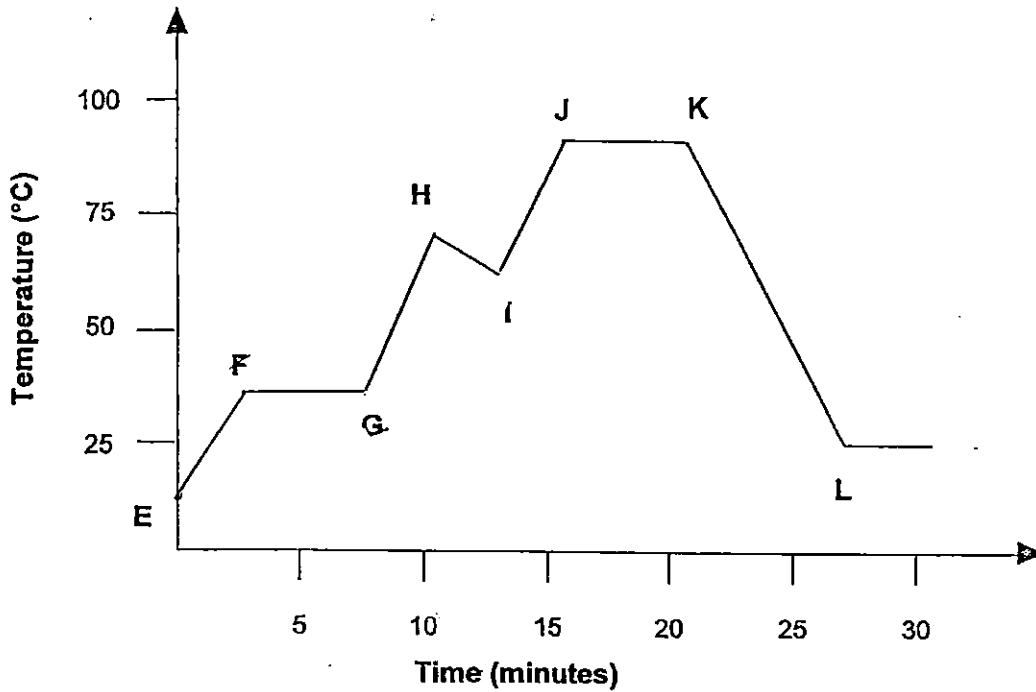

- (a) Why did the temperature of Substance W remain the same between points F and G? (1m)
-
- (b) There is a drop in temperature of Substance W between points H and I on the graph. Give a possible reason. (1m)
-
-
- (c) Based on the graph, what is the temperature of the room? (1m)
-

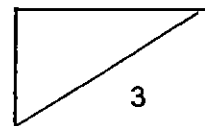

40. 4 identical towels, A, B, C and D, were soaked in the same amount of water and hung at different locations to dry for 30 minutes.

The graph below shows the change in the mass of the towels over 30 minutes.

Mass of towels (g)

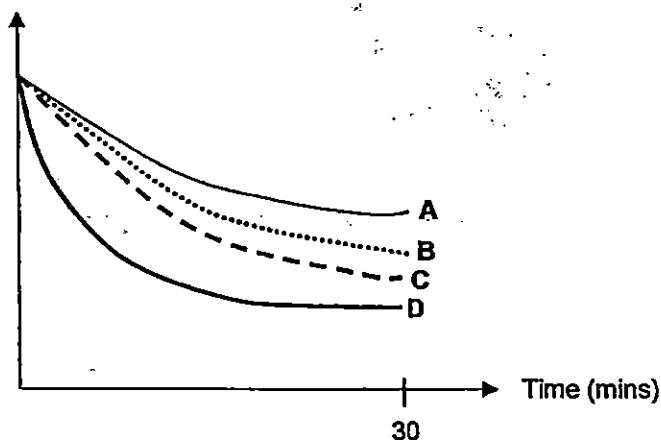

- (a) Based on the graph, which towel was exposed to the least amount of wind?
(1m)

- (b) Based on the experiment above, tick (✓) the variables that had been kept the same to ensure a fair test. (2m)

Variables that had been kept the same	Tick (✓)
Mass of the towels (at the end of experiment)	
Temperature of surrounding air	
The exposed surface area of the towels	
Duration of the experiment	

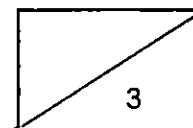

41. Mrs Cheng boiled some soup for her daughter. She left it to cool on the dining table for about 10 minutes.

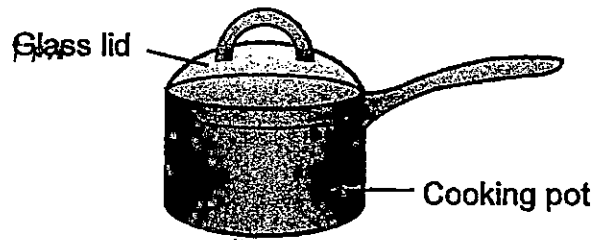

- (a) Explain why water droplets could be seen on the inner side of the glass lid after 10 minutes. (2m)

- (b) Explain why water droplets did not form on the outer side of the glass lid. (1m)

- (c) Mr Cheng took out another pot from the refrigerator. He also noticed some water droplets after 10 minutes. Draw the water droplets he was likely to see on the diagram below. (1m)

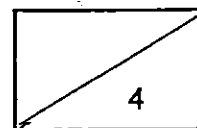
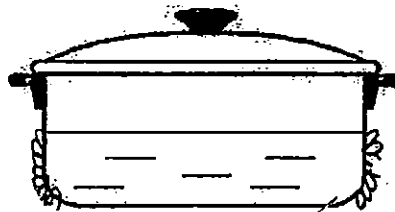

42. Sam placed a U-shaped copper rod into 2 beakers, A and B, each containing water of a different temperature. The arrow in the diagram below indicates how heat travelled through the rod immediately after it was immersed into the 2 beakers.

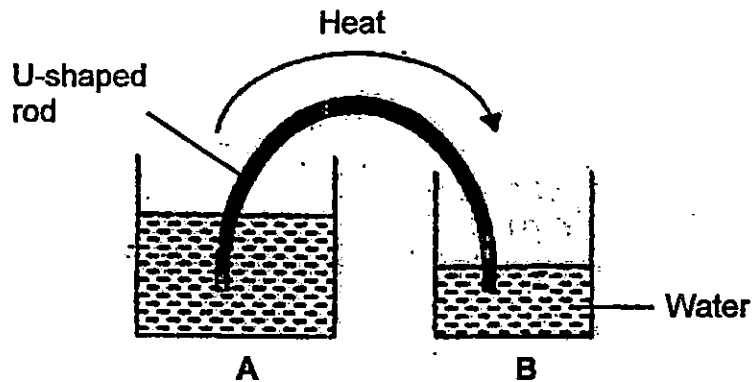

- (a) Which beaker contains hot water and water at 27°C ? (1m)

Hot water: Beaker _____

Water at 27°C : Beaker _____

- (b) Sam repeated the experiment but this time, he used a plastic rod instead of a copper rod. He observed that it took a longer time for heat to be transferred from water in Beaker A to the water in Beaker B. Explain why this happened. (2m)

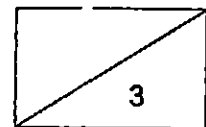

43. Benaiah sets up the following experiment. He places a rectangular opaque object, Object Q, at different positions, 1, 2, 3 and 4. He measures and records the height of the shadow of Object Q when it is placed at the different positions.

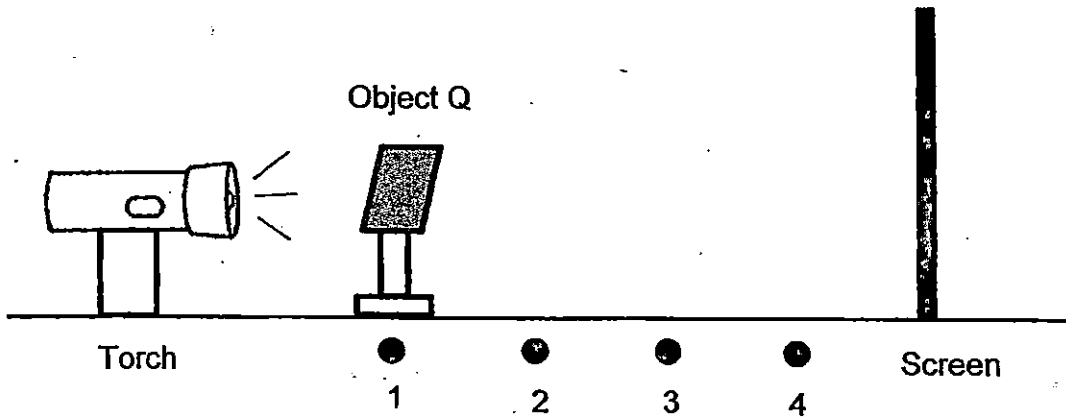

Predict and draw a line graph below, to show how the size of the shadow of Object Q will change with positions 1, 2, 3 and 4. (2m)

Size of shadow

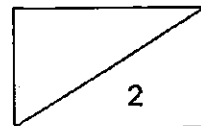
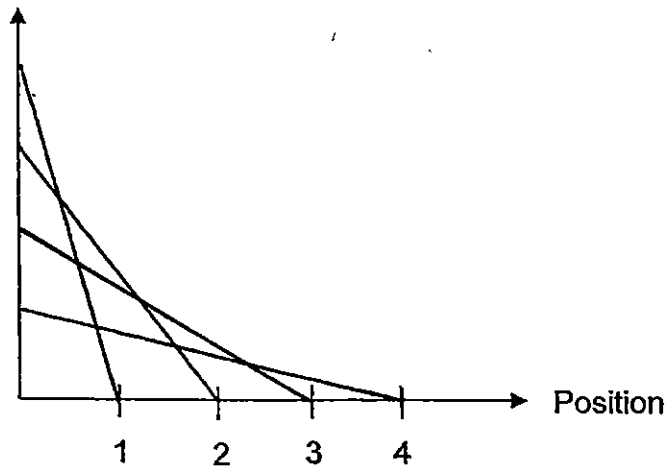

44. Xiao Rong was given 3 objects, A, B and C, each of a different unknown material, for her light experiment. They are as shown below.

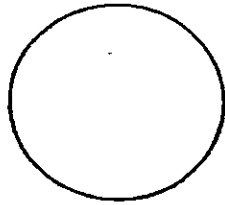

A

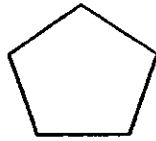

B



C

She managed to use the 3 objects, one in front of another as shown below, to form an image on the screen.

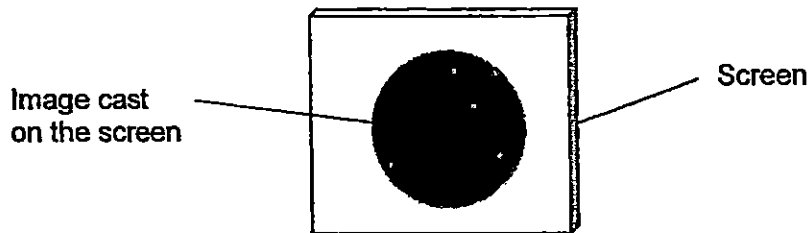
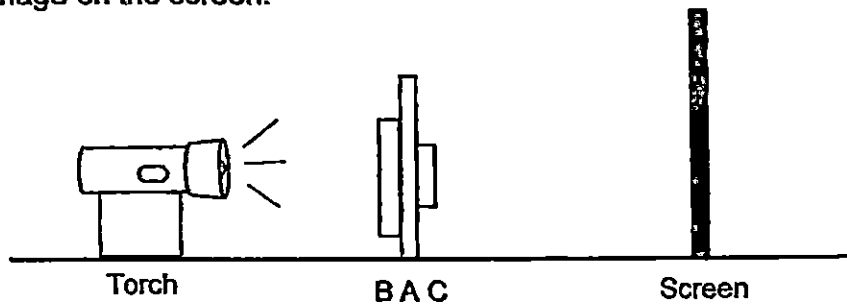

Xiao Rong's teacher gave her a table to identify some of the materials' characteristics. Based on the observation above, put a tick (✓) in the correct boxes. (3m)

Statement	True	False	Not possible to tell
A is opaque.			
B is transparent.			
C is translucent.			

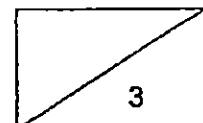



2015 P5 SA1 – Model Answers

1)	3	6)	2	11)	3	16)	2	21)	1	26)	4
2)	3	7)	2	12)	4	17)	4	22)	2	27)	2
3)	2	8)	2	13)	3	18)	4	23)	1	28)	1
4)	4	9)	4	14)	2	19)	1	24)	2	29)	1
5)	3	10)	4	15)	3	20)	2	25)	3	30)	1

Qn	Accepted Answer												
31 (a)	A: Gullet / Anus												
(b)	B: Large Intestine												
(c)	C: Small Intestine												
(d)	D: Stomach												
32(a)	Cell B. Cell B should have a cell membrane.												
32(b)	Animal cells. They do not have cell wall.												
33	<table border="1"> <thead> <tr> <th>Statement</th> <th>True</th> <th>False</th> </tr> </thead> <tbody> <tr> <td>Part R is the only part that allows air in and out of the body.</td> <td></td> <td>✓</td> </tr> <tr> <td>Oxygen is absorbed by the blood at Part S.</td> <td></td> <td>✓</td> </tr> <tr> <td>Only oxygen can pass through Part S.</td> <td></td> <td>✓</td> </tr> </tbody> </table>	Statement	True	False	Part R is the only part that allows air in and out of the body.		✓	Oxygen is absorbed by the blood at Part S.		✓	Only oxygen can pass through Part S.		✓
Statement	True	False											
Part R is the only part that allows air in and out of the body.		✓											
Oxygen is absorbed by the blood at Part S.		✓											
Only oxygen can pass through Part S.		✓											
34(a)	The greater the amount of oxygen in the water, the fewer/smaller the number of guppies near the water surface. Or The lesser the amount of oxygen in the water, the greater the number of guppies near the water surface.												
34(b)	The guppies did not have enough oxygen to survive.												
35(a)	Leaves Q and R. The stomata in Q and R are not blocked so they can still lose water vapour and the water vapour condensed onto the inner side of the plastic bag to form water droplets.												
35(b)	Y, Z, X												
36(a)	Object E is a magnet.												
36(b)	The part of Object F facing the part of Object E are like poles and the like poles repel one another.												
36(c)	S ; N												

1

37(a)	Mass of seedling: Q										
37(b)	Mass of seed leaves: V										
37(c)	The seedling used up the food in the seed leaves.										
38(a)	Plant 1: Dispersed by splitting / Dispersed by splitting with explosive action. Plant 2: Dispersed by Water										
38(b)	Brightly-coloured fruits, fleshy fruit, edible										
39 (a)	Substance W is melting.										
39 (b)	Ice cubes were added into the beaker.										
39 (c)	25°C										
40(a)	Towel A. (1m)										
40(b)	<table border="1"> <thead> <tr> <th>Variables that had been kept the same</th> <th>Tick (✓)</th> </tr> </thead> <tbody> <tr> <td>Mass of the towels (at the end of experiment)</td> <td></td> </tr> <tr> <td>Temperature of surrounding air</td> <td>✓</td> </tr> <tr> <td>The exposed surface area of the towels</td> <td>✓</td> </tr> <tr> <td>Duration of the experiment</td> <td>✓</td> </tr> </tbody> </table>	Variables that had been kept the same	Tick (✓)	Mass of the towels (at the end of experiment)		Temperature of surrounding air	✓	The exposed surface area of the towels	✓	Duration of the experiment	✓
Variables that had been kept the same	Tick (✓)										
Mass of the towels (at the end of experiment)											
Temperature of surrounding air	✓										
The exposed surface area of the towels	✓										
Duration of the experiment	✓										
41(a)	The soup evaporated and turned into water vapour. Warmer water vapour from the soup condensed on the cooler inner side of the glass lid to form water droplets.										
41(b)	Water vapour in the surrounding air was not warm enough to condense on the glass lid, which is warmer than the water vapour. Or The temperature of the glass lid was higher than the temperature of the water vapour in the surrounding, so condensation cannot take place.										
41(c)	Water droplets → drawn on the outer surface of the pot										
42(a)	Hot water: Beaker A Water at 27°C: Beaker B										
42(b)	Plastic is a poorer conductor of heat than copper, so it will conduct heat from the water in Beaker A to the water in Beaker B at a slower rate.										

2

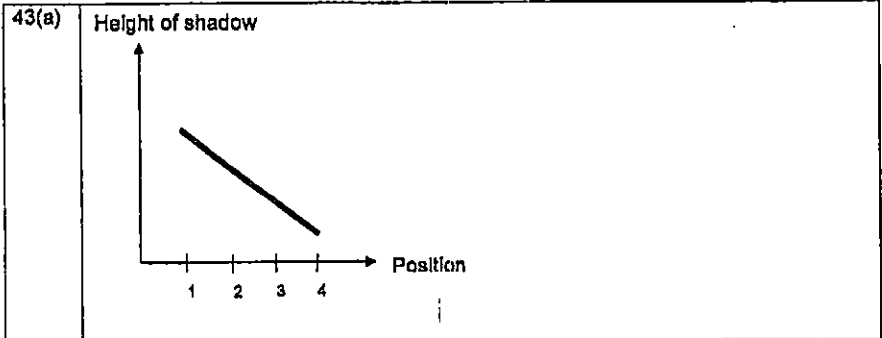

44

Statement	True	False	Not possible to tell
A is opaque.	✓		
B is transparent.			✓
C is translucent.			✓

2
END