



SEMESTRAL ASSESSMENT (2)  
2015

Section B	40
Your score out of 90	90
Parent's signature	

Name : \_\_\_\_\_ Index No: \_\_\_\_\_ Class: P 5 \_\_\_\_\_

27 October 2015 **SCIENCE** Attn: 1 h 30 min

**SECTION A (25 X 2 marks)**

For each question from 1 to 25, four options are given. One of them is the correct answer. Make your choice (1, 2, 3 or 4). Shade the correct oval on the Optical Answer Sheet.

1. The diagram below shows David's family tree

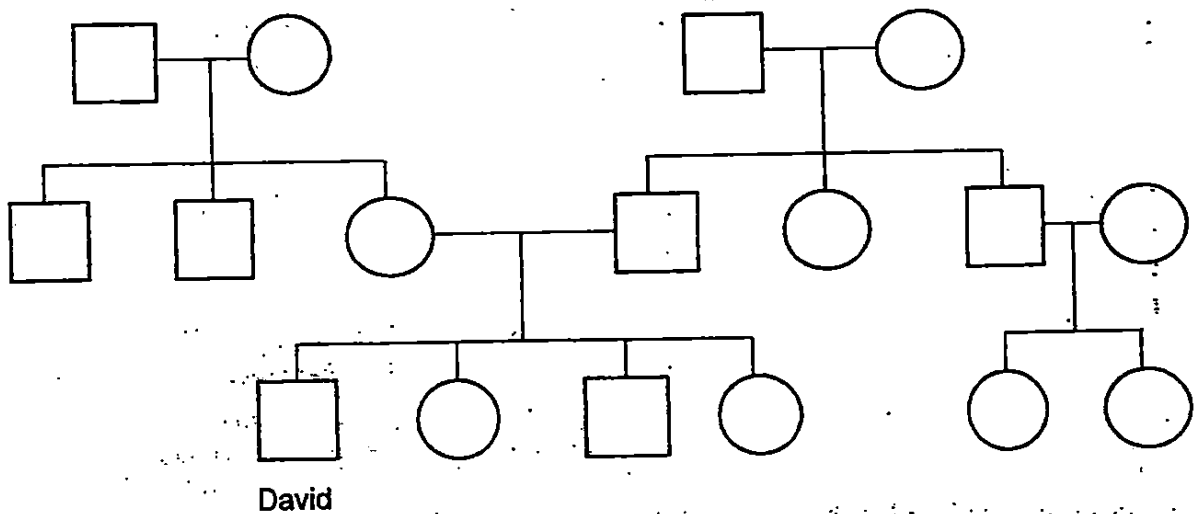
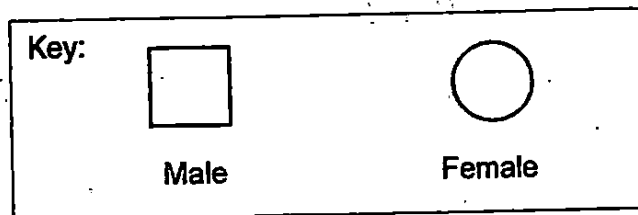

Which of the following about David's family tree is true?

- (1) David has four uncles
- (2) David has three aunts
- (3) David has two male cousins.
- (4) David has two sisters and one brother.

Draw and label the parts of the reproductive system of a plant and the human reproductive system:

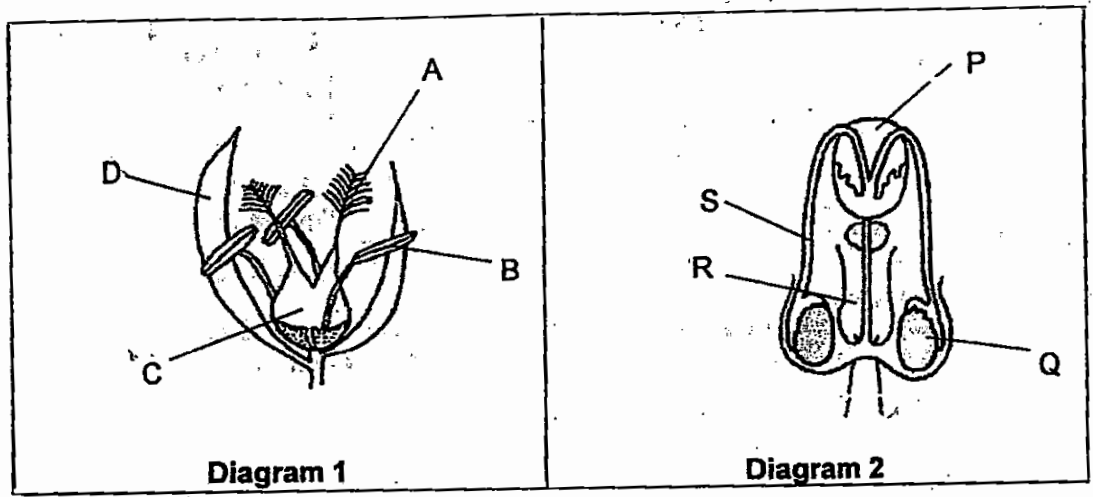

Which one of the following is correct?

	Diagram 1	Diagram 2
	Part that produces female sex cells	Part that produces male sex cells
(1)	A	R
(2)	B	P
(3)	C	Q
(4)	D	S

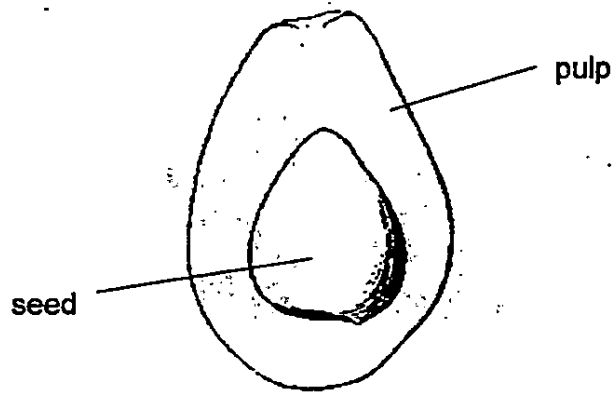

**Fruit Z**

Which of the following statements are most likely to be true about the flower which fruit Z has developed from?

- A The flower has only one ovary.
- B The flower does not have a stigma.
- C The fruit was developed from a flower with only female parts.
- D The flower went through fertilisation before the fruit was developed.

- (1) A and B only
- (2) A and D only
- (3) B and C only
- (4) B and D only

4. An experiment was set up using 4 pots of identical insect-pollinated flowers in a garden. Different parts of the flowers were removed. Insects were observed to be visiting the flowers. A tick (✓) shows the presence of the parts of the flowers in the table below.

Group of flowers	Anthers	Stigma	Petals
P		✓	
Q	✓		
R		✓	✓
S	✓		✓

Which group of flowers, P, Q, R or S, are most likely to develop into fruits after three weeks?

- (1) P and S
- (2) P and R
- (3) Q and R
- (4) Q and S

... an experiment as shown below. She wrapped three leaves from a plant in 3 different types of plastic bags. The plastic bags were of the same size. She left the plant under bright light for some time.

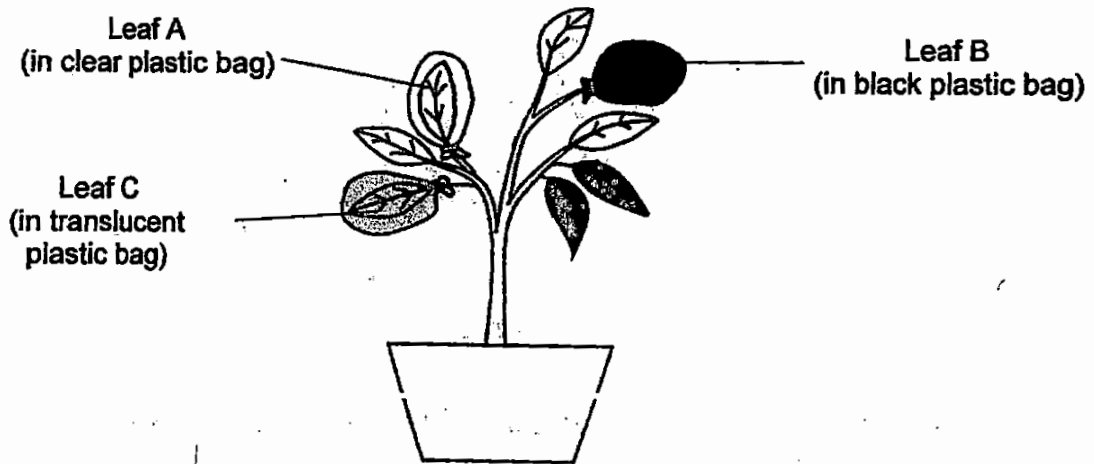

Which one of the following graphs correctly represents the amount of oxygen in the plastic bags after several hours?

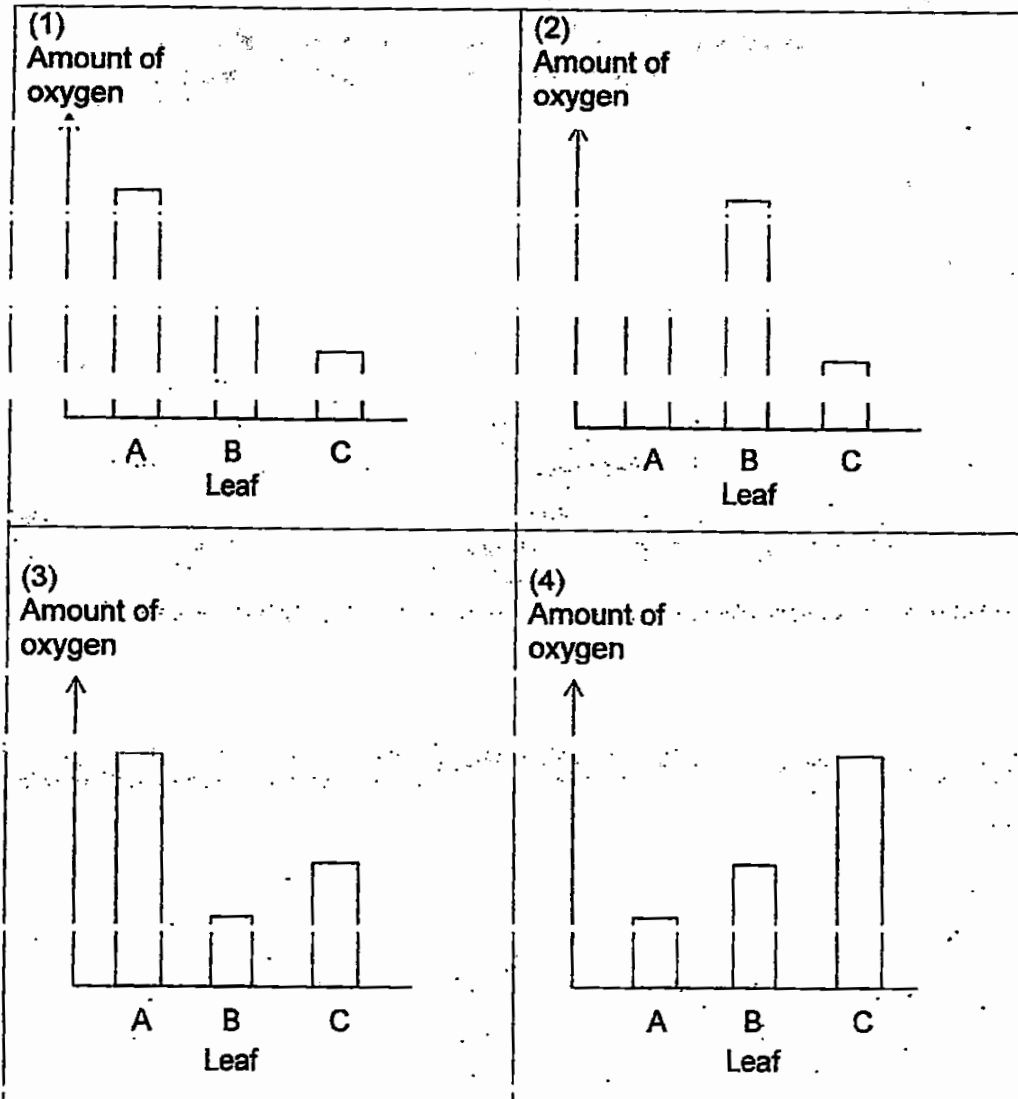

6. The diagram below shows parts of the human digestive system.

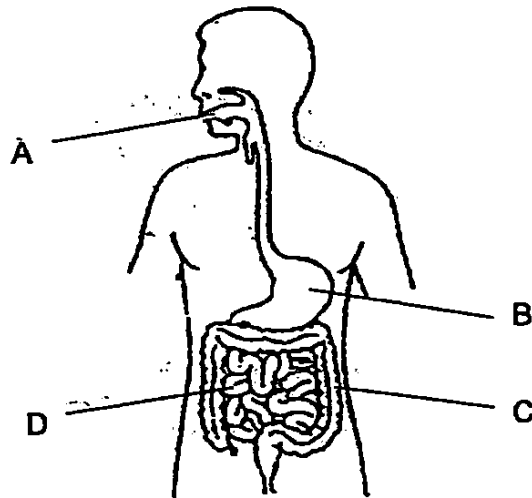

Based on the diagram, which one of the following is correct?

	<b>Organs involved in digestion of food</b>	<b>Organs involved in the absorption of digested food</b>
(1)	A and B only	C and D only
(2)	A, B and C only	C only
(3)	A, B and D only	D only
(4)	A, B, C and D	C and D only

Table 1 and 2 below show the PSI Readings (Pollutant Standards Index) on a particular day, the air quality descriptor and health advisory. PSI is an index to show the level of air quality. In order to reduce the ill effects from being exposed to haze, people should reduce outdoor activities and outdoor physical exertion.

**Table 1: PSI Readings**

Time	8am	9am	10am	11am	12pm	1pm	2pm	3pm	4pm
PSI	310	286	255	189	165	138	115	91	79

**Table 2: Air Quality Descriptors and Health Advisory**

PSI Value	Air Quality Descriptor	Health Advisory for healthy persons
0 – 50	Good	Normal activities
51 – 100	Moderate	Normal activities
101 – 200	Unhealthy	Reduce outdoor physical exertion
201 - 300	Very unhealthy	Avoid outdoor physical exertion
Above 300	Hazardous	Minimise outdoor activity

Based on the information above, which is the best time of the day for Peter (a healthy person) to go for a run at the park?

- (1) 8 am
- (2) 10 am
- (3) 12 pm
- (4) 3 pm

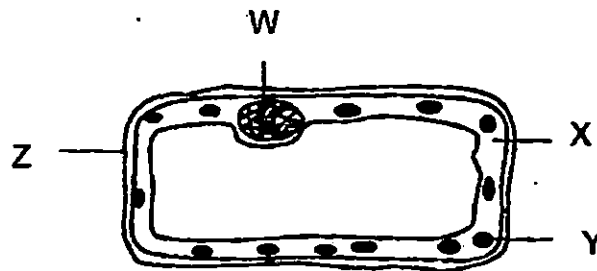

After looking at the cell, four children made the following statements:

Alice : It is likely to be an animal cell.

Bernice : W controls all the activities of the cell.

Charlie : X is a substance that contains different parts of the cell.

Dan : Y controls the movement of substances in and out of the cell.

Whose statement(s) is/are correct?

- (1) Alice only
- (2) Charlie and Dan
- (3) Bernice and Charlie
- (4) Alice, Bernice and Charlie

9. Which of the following statements about the circulatory system is true?

- (1) It does not carry waste materials.
- (2) It transports air from the nose to the heart only.
- (3) It transports blood to the heart and lungs only.
- (4) It transports digested food to various parts of the body.

The following graph shows Gina's heart rate over a few hours:

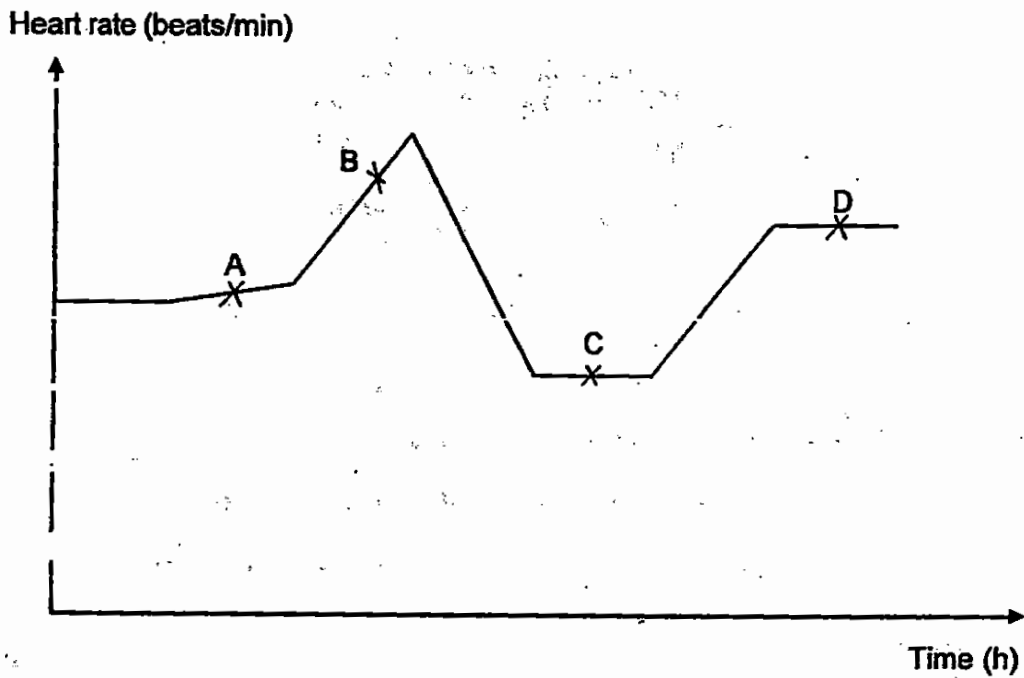

Which one of the following **best** represents Gina's activities as shown by the graph above?

	A	B	C	D
(1)	sleeping	skipping	walking	reading
(2)	reading	skipping	sleeping	walking
(3)	sleeping	walking	running	reading
(4)	walking	reading	running	sleeping



11. An experiment was carried out by placing two hamsters in a sealed container for one hour.

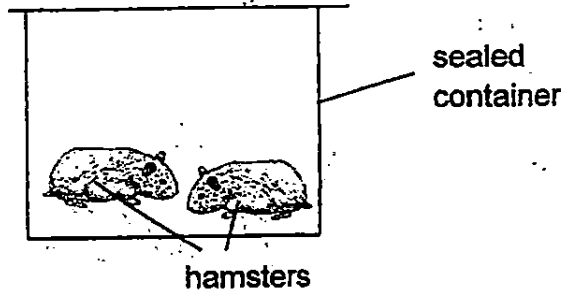

Which one of the following shows the change in amount of gases in the container after one hour?

	Carbon Dioxide	Oxygen	Water Vapour
(1)	increased	decreased	increased
(2)	increased	decreased	decreased
(3)	decreased	increased	remained the same
(4)	decreased	increased	increased

12. Devi wants to carry out an experiment to investigate the effect of the length of the wingspan on the time taken for a paper spinner to reach the ground.

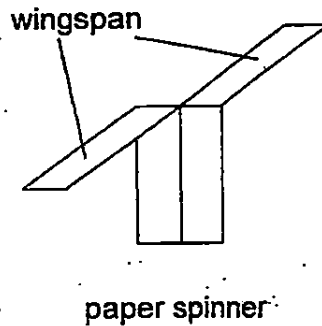

Which are the variables she should keep constant to ensure a fair test?

- A Colour of the paper spinner.
- B Length of wingspan of paper spinner.
- C Type of paper the paper spinner is made of.
- D Height from which the paper spinner is released.

- (1) A and B only
- (2) C and D only
- (3) B, C and D only
- (4) A, B, C and D

Tom removed the outer covering on a part of the stem of a plant as shown in the diagram below. After one week, Tom observed that a fruit, which was growing below the cut, became smaller and shrivelled up.

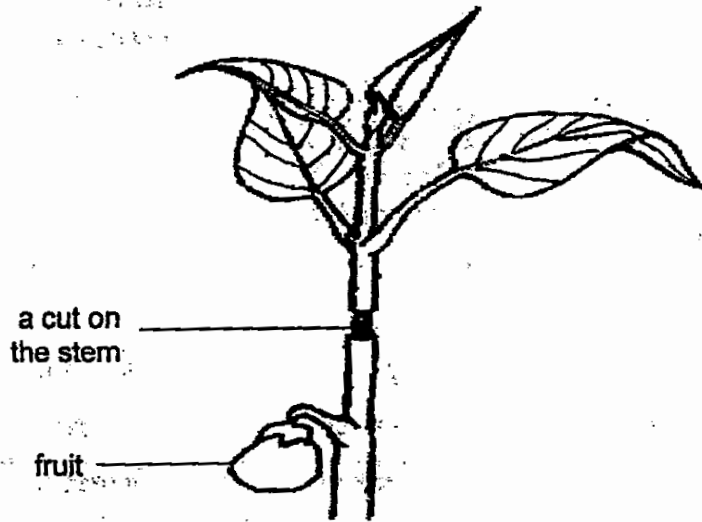

Based on the information above, which one of the following diagrams will represent the appearance of the stem where the cut was made after one week?

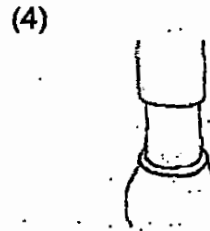
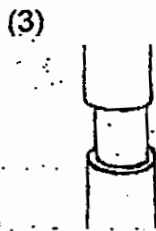
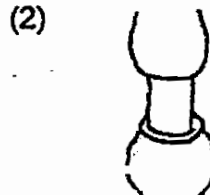

of water taken in by a plant. She placed a plant in a container as shown in the diagram below.

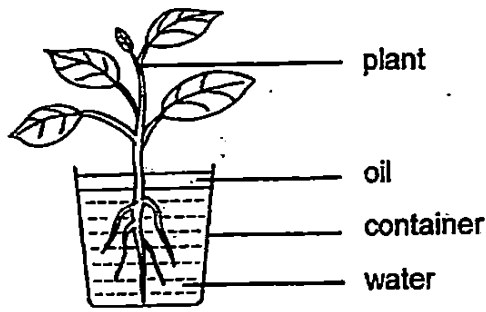

Which one of the following set-ups should she compare with in order to ensure a fair test?

<p>(1)</p> <p>A diagram showing a plant in a container. The container is filled with water. The plant's roots are submerged in the water. Labels 'plant' and 'container' are present.</p>	<p>(2)</p> <p>A diagram showing a plant in a container. The container is filled with two distinct liquid layers: oil on top and water on the bottom. The plant's roots are submerged in the water layer. Labels 'plant', 'container', and 'water' are present.</p>
<p>(3)</p> <p>A diagram showing a plant in a container. The container is filled with water. The plant's roots are submerged in the water. Labels 'plant', 'container', and 'water' are present.</p>	<p>(4)</p> <p>A diagram showing a plant in a container. The container is filled with two distinct liquid layers: oil on top and water on the bottom. The plant's roots are submerged in the water layer. Labels 'plant', 'oil', 'container', and 'water' are present.</p>

shown in the diagram below.

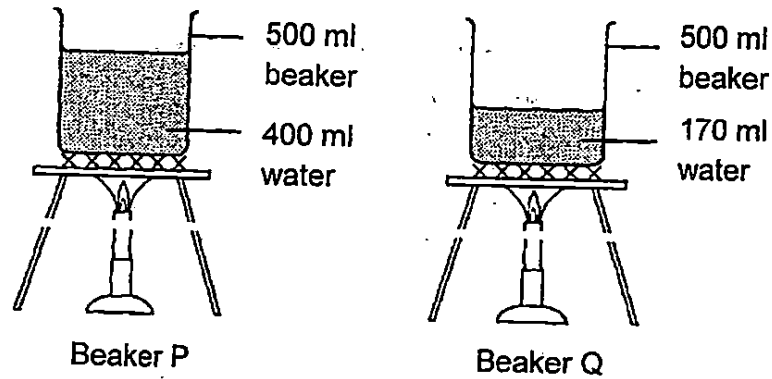

Which of the statement(s) about the two beakers of water is/are true?

- A Both beakers of water would boil at the same time.
  - B The boiling water in Beaker P would have more amount of heat than the boiling water in Beaker Q.
  - C Both beakers of water would have the same temperature when they were boiling.
- (1) C only  
(2) A and B only  
(3) B and C only  
(4) A and C only

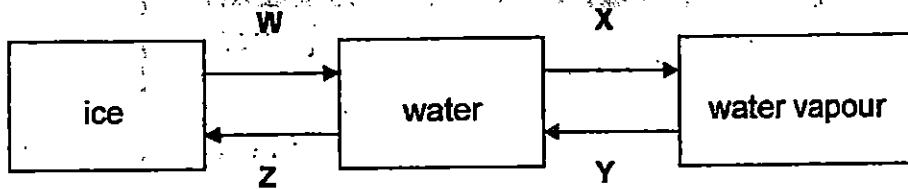

Based on the diagram above, which one of the following correctly represents the processes W, X, Y and Z?

	W	X	Y	Z
(1)	Melting	Condensation	Freezing	Evaporation
(2)	Evaporation	Freezing	Melting	Condensation
(3)	Melting	Evaporation	Condensation	Freezing
(4)	Freezing	Condensation	Evaporation	Melting

17. Susan is sitting at a corner of a room reading a book as shown in the diagram below.

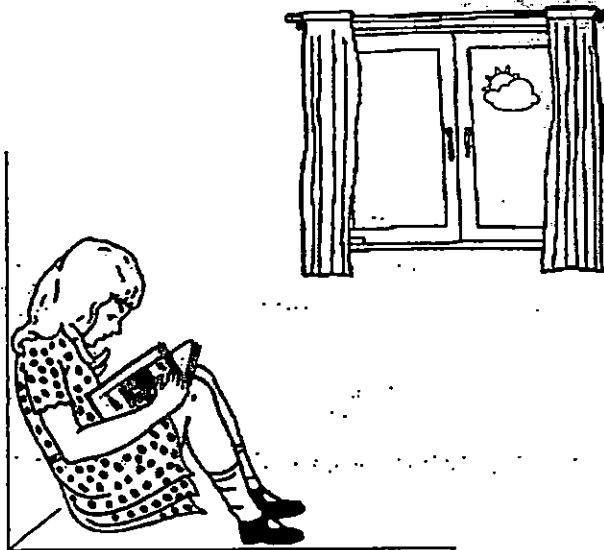

Which one of the following statements correctly explains why she could see the words on her book clearly?

- (1) Light from the sun enters Susan's eyes.
- (2) Light produced by the book enters Susan's eyes.
- (3) Susan's eyes reflect light from the sun into the book.
- (4) The book reflects light from the sun into Susan's eyes.

Diagram below show a torch shining on three objects X, Y and Z. Objects X AND Z are shapes made of cardboard. They are placed at different distances from the torch.

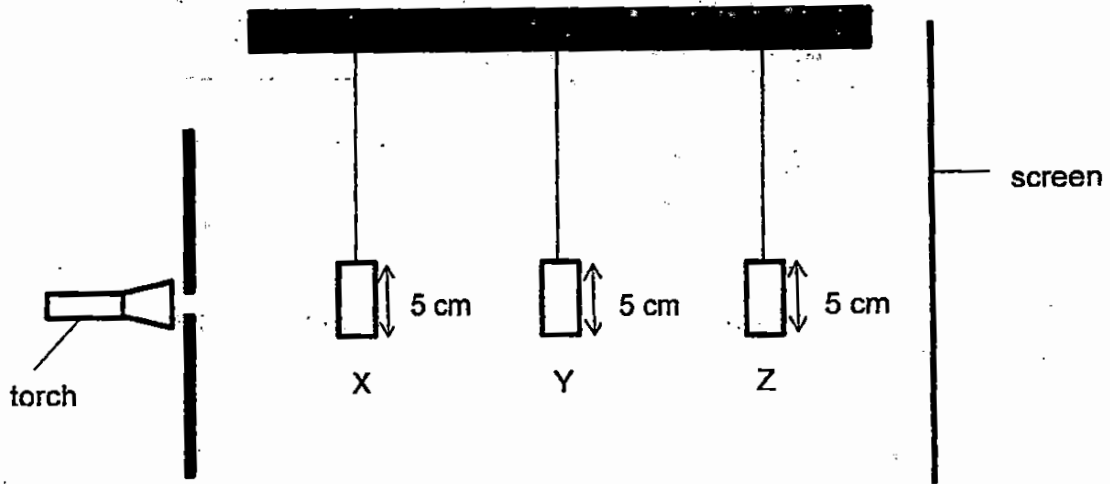

The shapes of the objects are as follows:

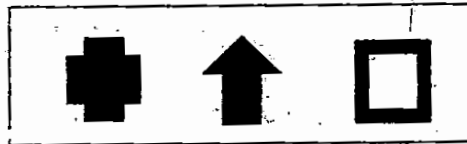

The diagram below shows the shadow that was cast on the screen.



Which one of the following represents correctly objects X, Y and Z respectively?

	X	Y	Z
(1)	↑	□	+
(2)	↑	+	□
(3)	□	+	↑
(4)	+	□	↑

19. Ahmad set up an experiment as shown below. He poured equal amounts of two different liquids, A and B, into identical beakers. The liquids were heated using identical heaters with the same amount of heat that were immersed in the liquids.

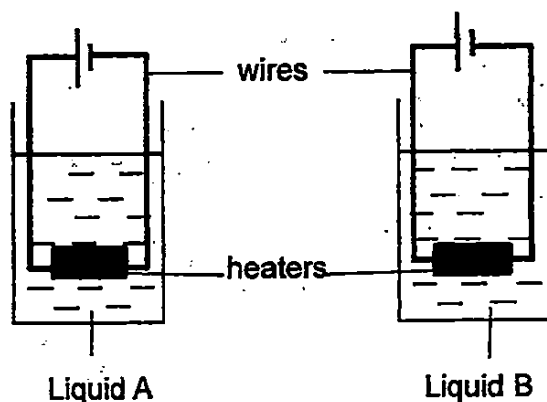

The table below shows the results recorded by Ahmad after 20 minutes.

Liquid	Temperature (°C)	
	At the start of the experiment	At the end of the experiment
A	20	30
B	20	35

Based on the results above, which one of the following statements correctly explains the results?

- (1) Liquids A and B take up space.
- (2) Liquid B gains heat faster than Liquid A.
- (3) Liquids A and B have no definite volume.
- (4) Liquid A is a better conductor of electricity than Liquid B.

The diagram below shows rods P, Q, R and S of the same length inserted into a container of hot water. Equal amount of wax was used to attach the thumbtacks to the respective rods.

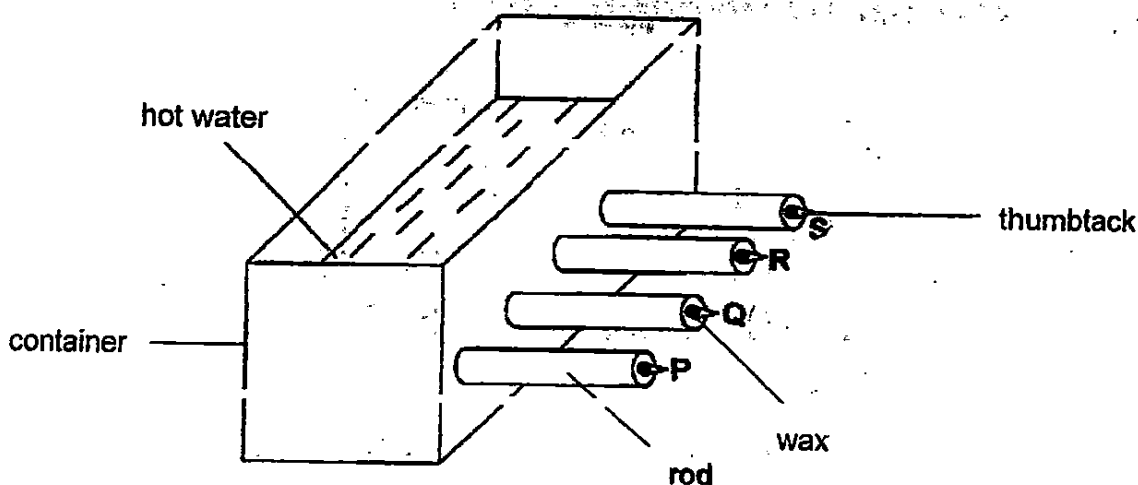

It was observed that thumbtack on rod P dropped off first, followed by the thumbtack on Q, then R and lastly S.

Which one of the following statements correctly explains the above observations?

- (1) Rods P and Q lose heat quickly.
- (2) Rods S is the poorest conductor of heat.
- (3) Rod S is a better conductor of heat than Rod R
- (4) Rod Q is a poorer conductor of heat than Rod R

21. Which one of the following shows the safe way to use electricity?

- (1) Switching on the fan with wet fingers.
- (2) Replacing an exposed wire with a new insulated wire.
- (3) Overloading an electrical outlet with many electrical appliances.
- (4) Inserting a metal rod into an electrical outlet to help insert a plug.



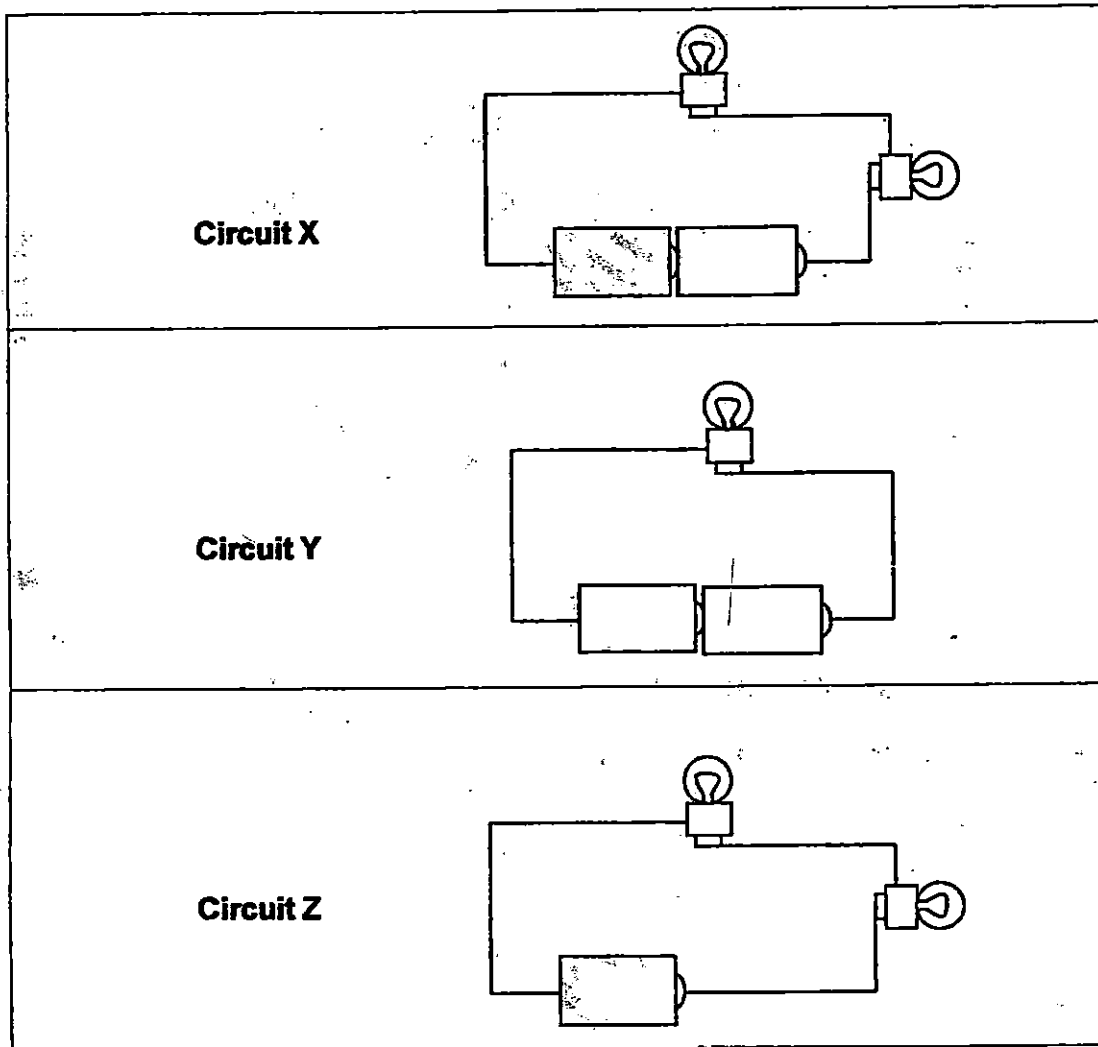

Which one of the following shows the correct order of the electric circuits when arranged according to the brightness of the bulbs, from the brightest to the dimmest?

- (1) X, Y, Z
- (2) X, Z, Y
- (3) Y, X, Z
- (4) Z, Y, X

20. The diagram below shows four bars, A, B, C and D, connected to a circuit:

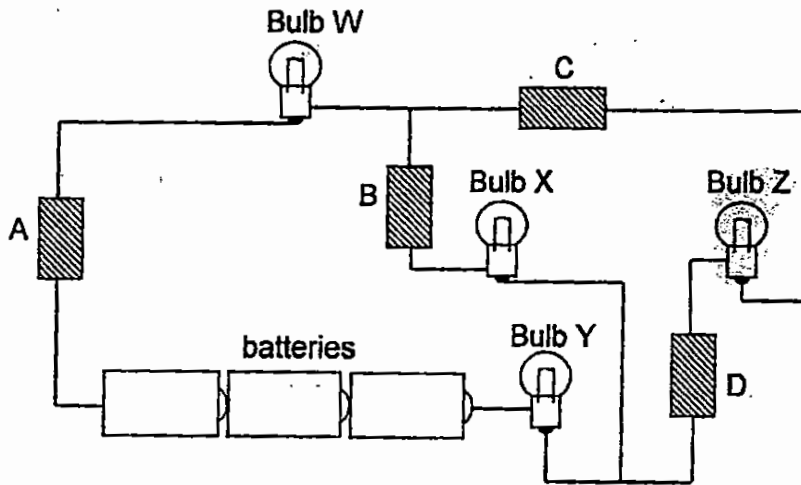

It was observed that only bulb Z did not light up.

Which one of the following materials could bars A, B, C and D be possibly made of?

	A	B	C	D
(1)	glass	plastic	aluminium	copper
(2)	copper	glass	iron	aluminium
(3)	iron	aluminium	copper	glass
(4)	plastic	copper	glass	iron

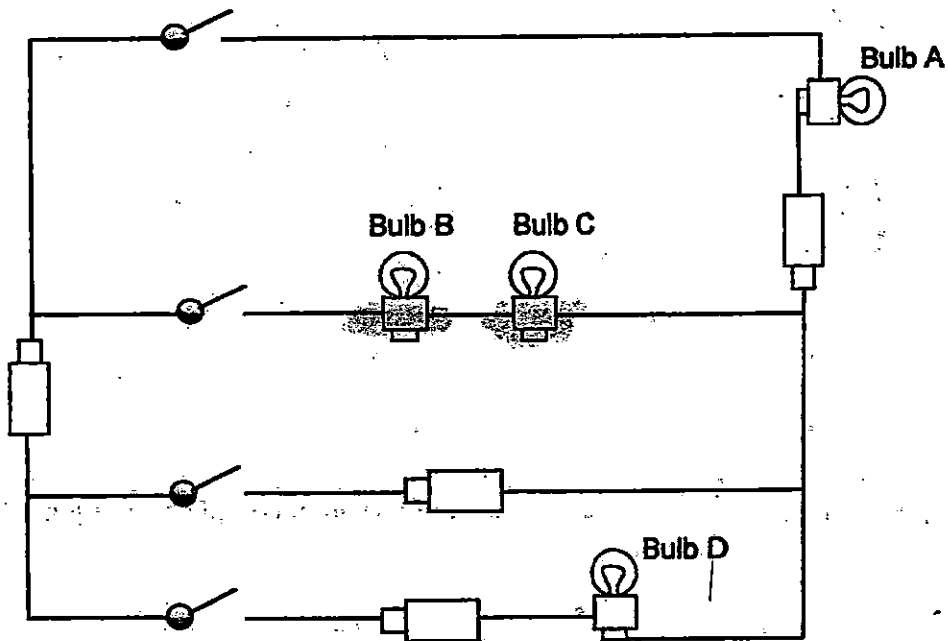

Which bulb(s) will light up when all the switches are closed?

- (1) Bulb A only
- (2) Bulbs A and D only
- (3) Bulbs A, B and C only
- (4) Bulbs A, B, C and D

20. The diagram below shows the arrangement of five magnets when they are attracted to each other.

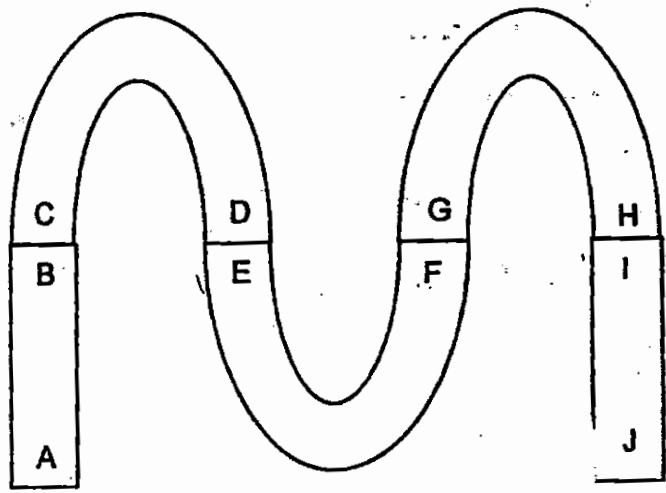

Which of the following shows the correct interaction between two of the magnets?

<p>(1)</p>	<p>(2)</p>
<p>(3)</p>	<p>(4)</p>

**SECTION B (40 marks)**

For questions 26 to 39, write your answers clearly in the spaces provided.  
The number of marks is shown in brackets [ ] at the end of each question or part question.

26. The diagram below shows the human fertilisation process. A and B are necessary for fertilisation to take place.

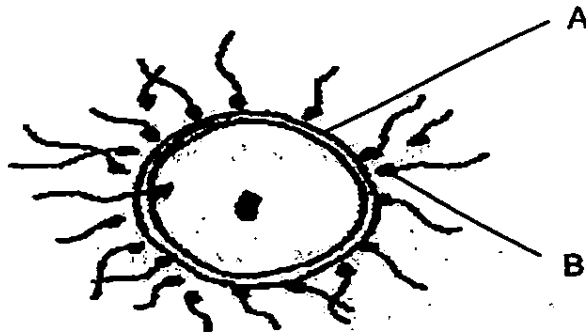

(a) Identify A and B.

[1]

A: \_\_\_\_\_

B: \_\_\_\_\_

(b) The diagram below shows the parts of the reproductive system of a plant and human.

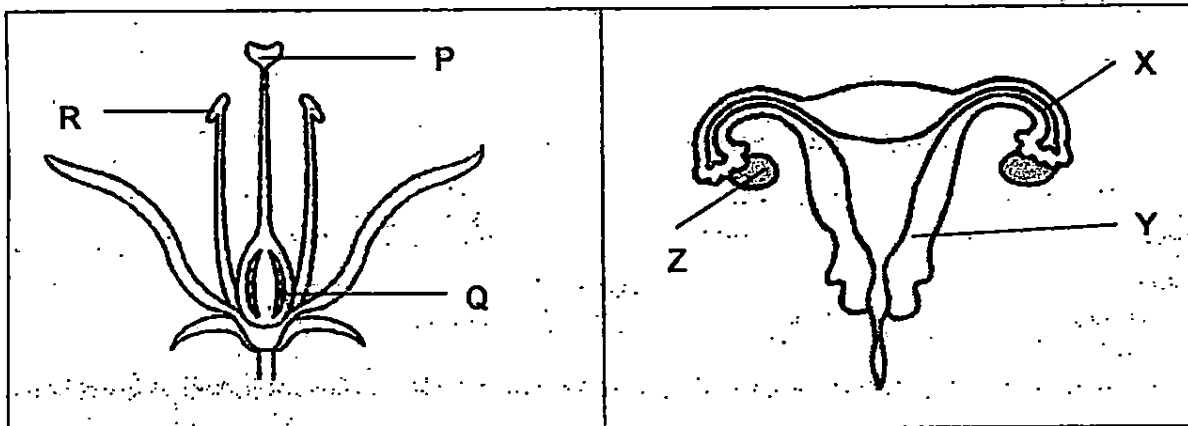

Identify the parts where fertilisation will take place in the plant and female reproductive system respectively. Write the letters that represent the parts in the boxes below. [2]

		Letter that represents the part
(i)	Reproductive system of a plant	
(ii)	Reproductive system of a human	

SCORE	3
-------	---

... out an experiment to find out if the presence of a wing-like structure would affect the time taken for a seed to reach the ground. He dropped Seed X, from a height of 6 metres and recorded the time taken for it to reach the ground. Then he cut off the wing-like structure, as shown in Diagram A, and repeated the above experiment.

He repeated the experiment two more times to get a second and third reading.

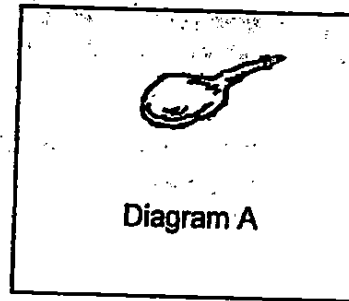
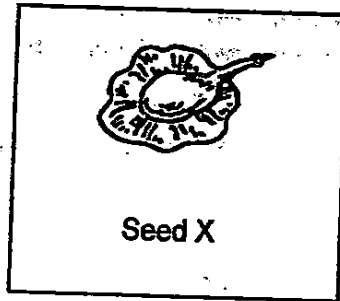

He recorded his results in a table as shown below.

	Time taken by seed to reach the ground (seconds)	
	Seed with wing-like structure	Seed without wing-like structure
1 <sup>st</sup> reading	7.9	4.5
2 <sup>nd</sup> reading	8.2	5.0
3 <sup>rd</sup> reading	7.3	4.8
Average	7.8	4.8

Answer the following questions based on the results in the table above.

- (a) State the method of dispersal of Seed X. [1]
- 
- (b) Why did Jun take more than one reading for his experiment? [1]
- 
- (c) Explain clearly why the seed with wing-like structure took a longer time to reach the ground. [1]
- 

SCORE	3
-------	---

28. Siti conducted an experiment to find out the effects of different coloured light on the stomata of tomato seedlings. She recorded her results in the table below.

Types of light	Average width of stomata (units)	Average length of stomata (units)
Sunlight (Control)	19.6	32.1
Green	23.4	33.4
Orange	18.5	29.7
Purple	18.8	28.9
Yellow	23.2	35.1

Answer the following questions based on the results in the table above.

- (a) Comparing with the control set-up, name the type(s) of light that will cause the stomata to be larger. [1]

---



---

- (b) Stomata allow the exchange of gases between the plant and the surrounding air. Under certain light conditions, the stomata become larger. State one advantage and disadvantage for the enlarged stomata. [2]

<b>Advantage</b>	
<b>Disadvantage</b>	

SCORE	3
-------	---

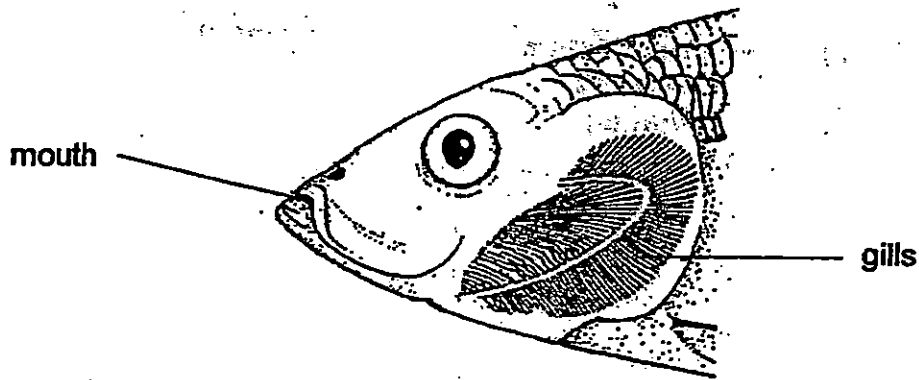

(a) Explain clearly how the increased surface area of the gills will benefit the fish. [2]

---



---

(b) The diagram below shows a woman blowing air into a test-tube of limewater.

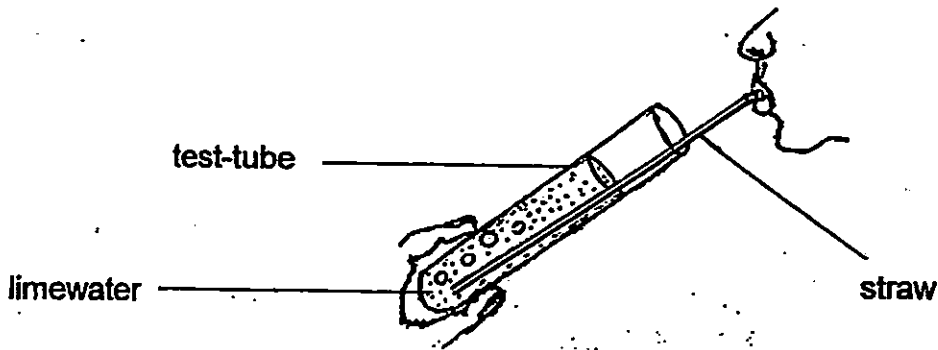

After a while, Mary noticed that the limewater turned chalky. Give a reason why the limewater turned chalky. [1]

---



---

SCORE	3
-------	---



30. Ming Ming obtained cells X and Y from two parts of the plant shown. Cell X was taken from P and cell Y was taken from Q.

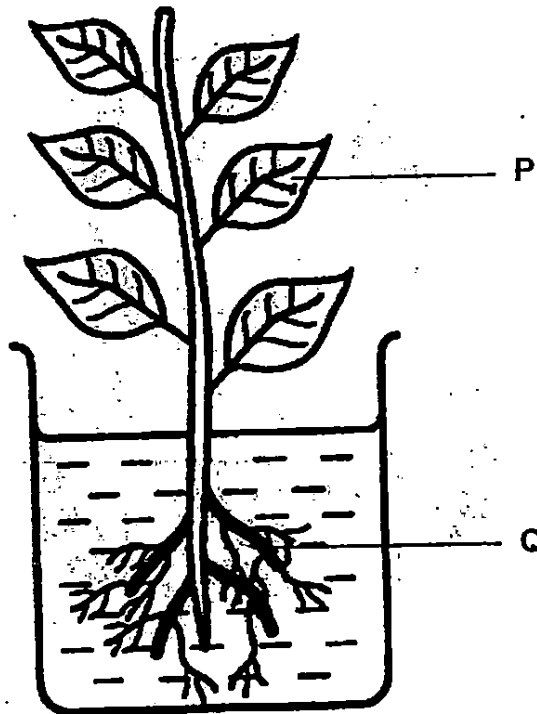

Ming Ming prepared the specimens of cells X and Y on two separate slides and observed the cells under a microscope.

- (a) State one difference between cells X and Y that Ming Ming would observe. [1]

---

---

- (b) Explain your answer in (a). [1]

---

---

- (c) State 2 similarities between cells X and Y and an animal cell. [1]

---

---

SCORE	3
-------	---

Diagram shows the flow of blood in blood vessels X and Y in a human system.

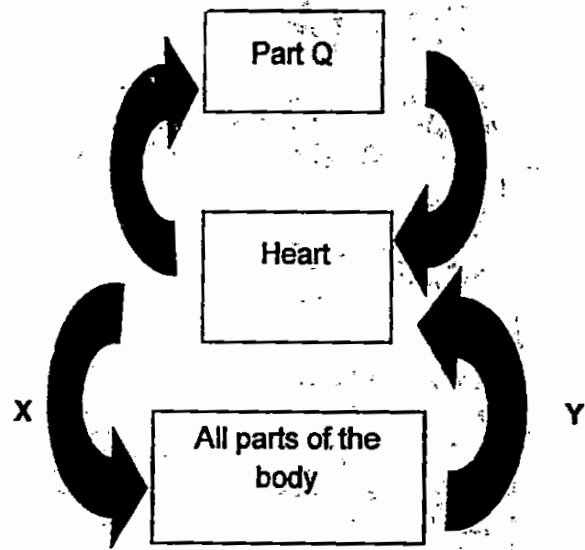

(a) Identify Part Q. [1]

---

(b) What is the difference between the amount of carbon dioxide in the blood flowing through blood vessels X and Y? [1]

---

---

SCORE	2
-------	---

32. Harold wanted to find out if the mass of an animal affects the amount of carbon dioxide it produces. He placed an ant, a lizard and a mouse in bell jars, A, B and C respectively, as shown in the diagram below. No animal was placed in bell jar D. He placed all the bell jars in a room with a constant temperature.

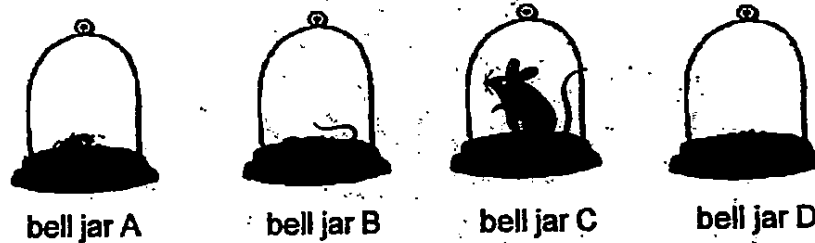

- (a) Put a tick (✓) beside the variable(s) that Harold should keep constant for a fair test. [2]

	Variable	Constant (✓)
(i)	Mass of animal	
(ii)	Type of bell jar	✓
(iii)	Amount of air in bell jar	
(iv)	Composition of air in bell jar	
(v)	Duration of each animal kept in bell jar	

The table below shows the percentage of carbon dioxide in the bell jar at the end of the experiment.

Bell Jar	Animal kept in bell jar	Mass of animal kept in bell jar (milligrams)	Percentage of carbon dioxide in bell jar after the experiment (%)
A	Ant	3	0.05
B	Lizard	9000	0.09
C	Mouse	35000	0.15
D	-	-	0.03

- (b) Based on the results above, what is the relationship between the mass of an animal and the amount of carbon dioxide it produces? [1]

---



---

SCORE	3
-------	---

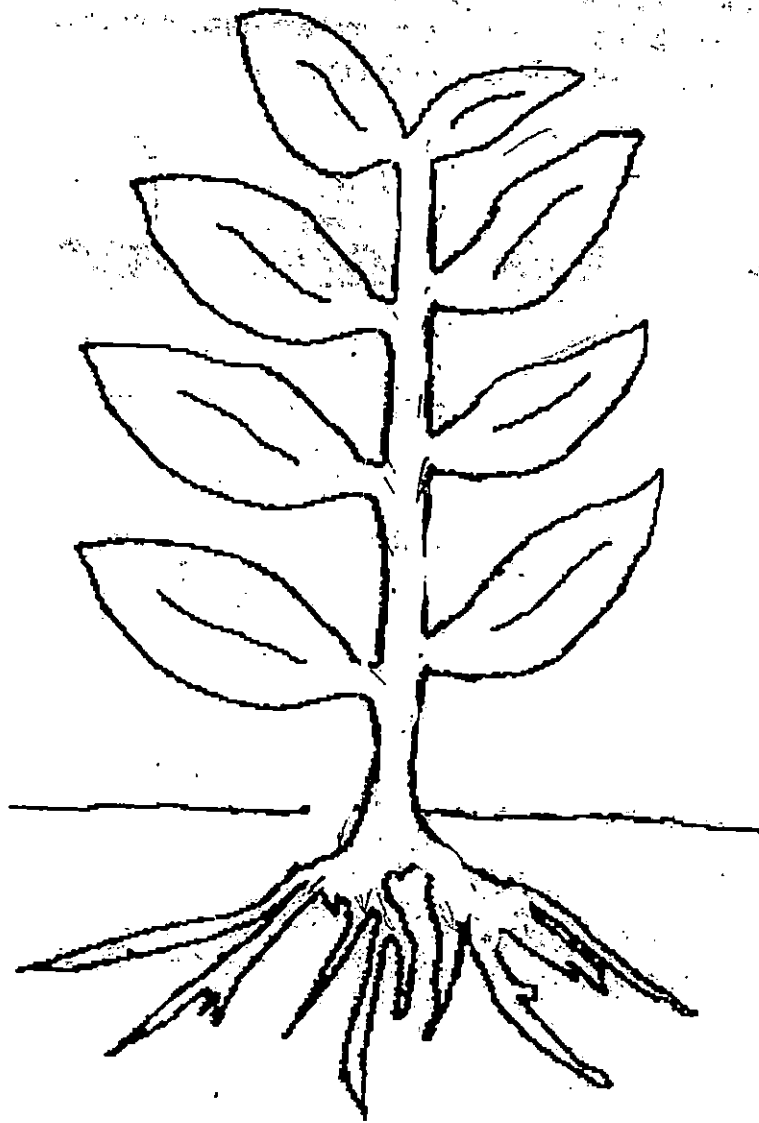

- (a) In the diagram above, label and name the part of the plant which makes food. [1]
- (b) Draw arrows (→) in the diagram above to show how the food produced is being transported to all parts of the plant. [1]

SCORE	2
-------	---

34. Gopal wanted to find out if the roots of a plant take in water. He prepared the experimental set-ups as shown below:

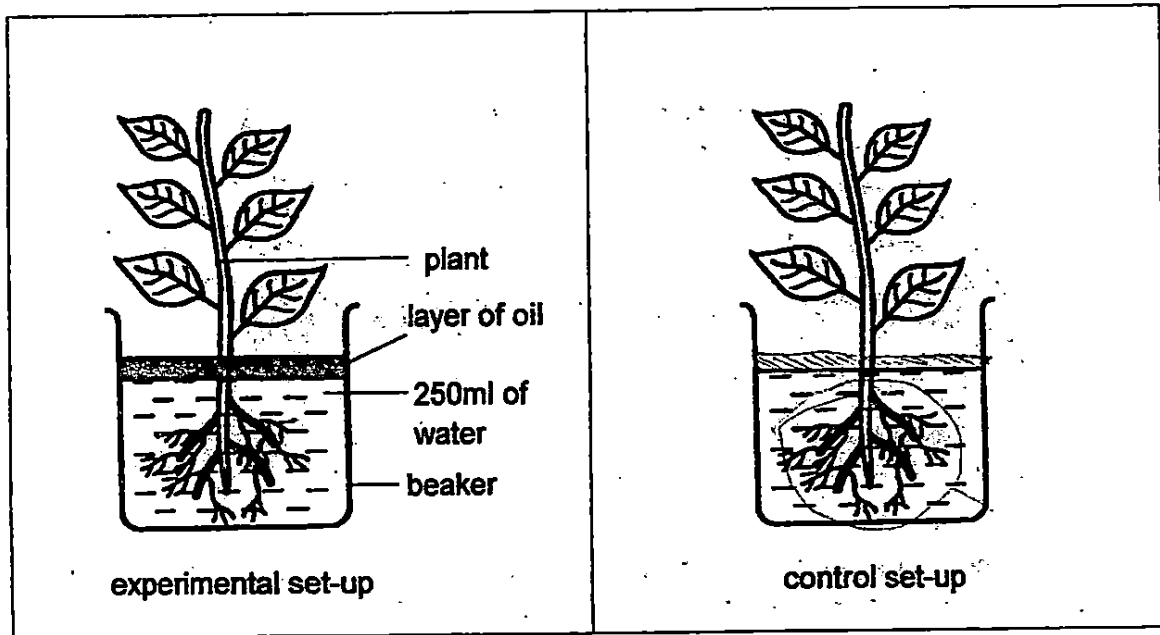

- (a) His teacher told him that his control set-up was incorrect. Without removing any part(s) of the plant in the control set-up, draw and label in the diagram above two changes that need to be made to the control set-up. [1]

- (b) What is the purpose of the control set-up in this experiment? [1]

---



---

- (c) Why did Gopal add a layer of oil to the beaker of water in the experimental set-up? [1]

---



---

SCORE	3
-------	---

Set-ups X and Y, each containing the same amount of sea water, as shown below to demonstrate the water cycle. She then left the set-ups at the same location under the sun.

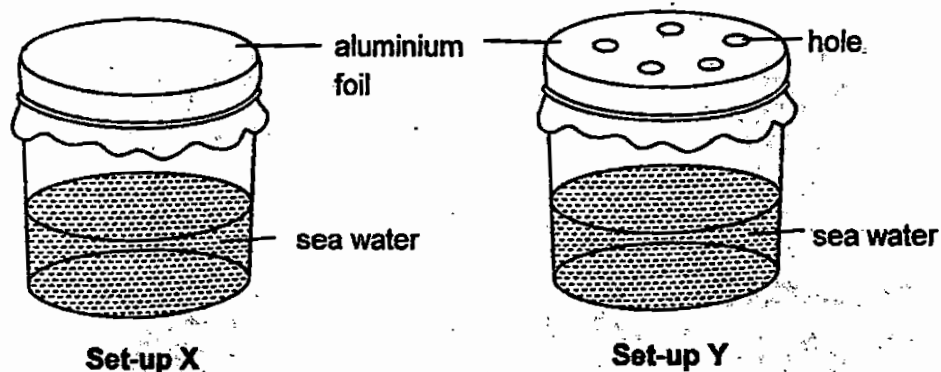

She checked the set-ups an hour later and found that different amount of water droplets were formed on the underside of the aluminium foil of set-ups X and Y.

- (a) Which set-up would have less water droplets formed on the underside of the aluminium foil? Explain your answer clearly. [2]

---

---

- (b) Suggest what Helen could do to further increase the rate of condensation in set-up X without replacing any parts of the set-up. [1]

---

---

SCORE	3
-------	---

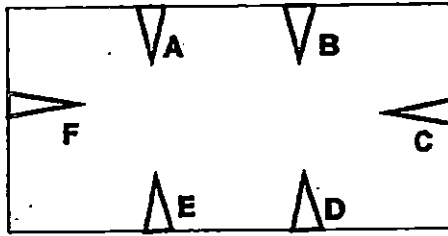

circuit card

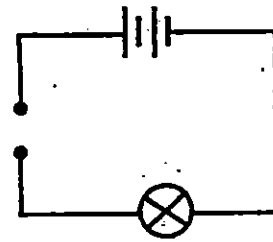

circuit tester

She tabulated the results in a table as shown below. A tick (✓) shows that the bulb lit up when the pair of paper clips was tested.

	A	B	C	D	E	F
A		✓		✓		
B	✓					
C						
D	✓					
E						✓
F					✓	

- (a) Based on the information given, using the least possible number of lines, draw how the wires are connected in the circuit card shown below: [1]

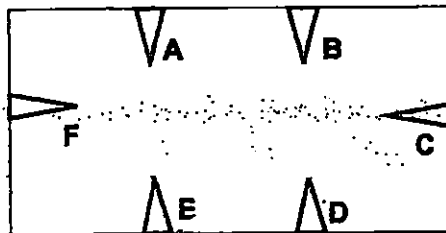

- (b) Name **ANOTHER** pair of paper clips, **NOT** shown in the table above, which would result in the bulb lighting up when connected. [1]

SCORE	2
-------	---

The diagram below shows the electrical circuit arrangement for two bulbs in the rooms, A and B.

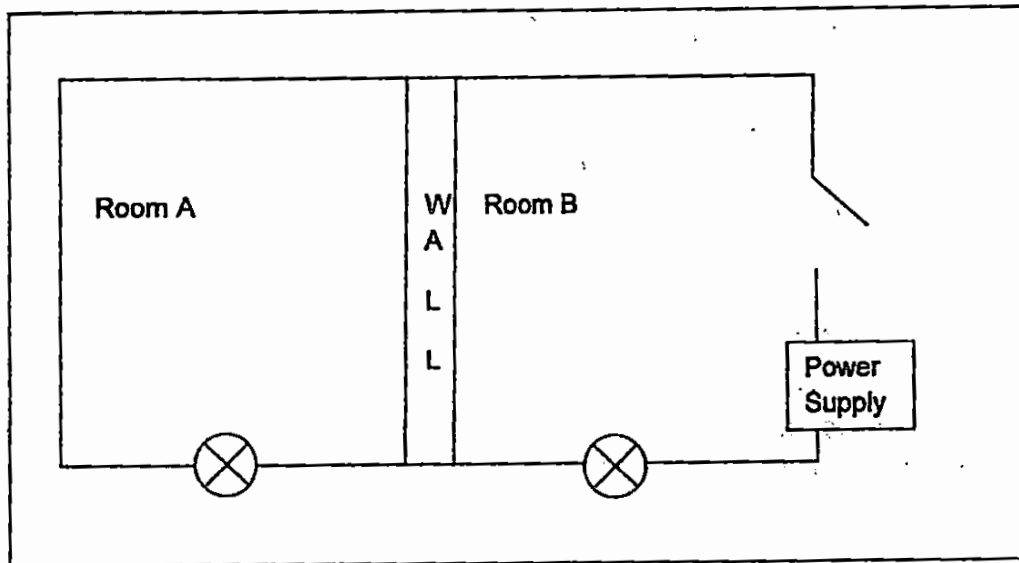

(a) Write down two disadvantages on the above circuit arrangement. [2]

<b>Disadvantage 1</b>	
<b>Disadvantage 2</b>	

Continue on the next page

<b>SCORE</b>	2
--------------	---



Continued from previous page

- (b) In the diagram below, draw a circuit diagram to address the disadvantages you wrote down in (a) using 2 bulbs, 2 switches and some wires. [2]

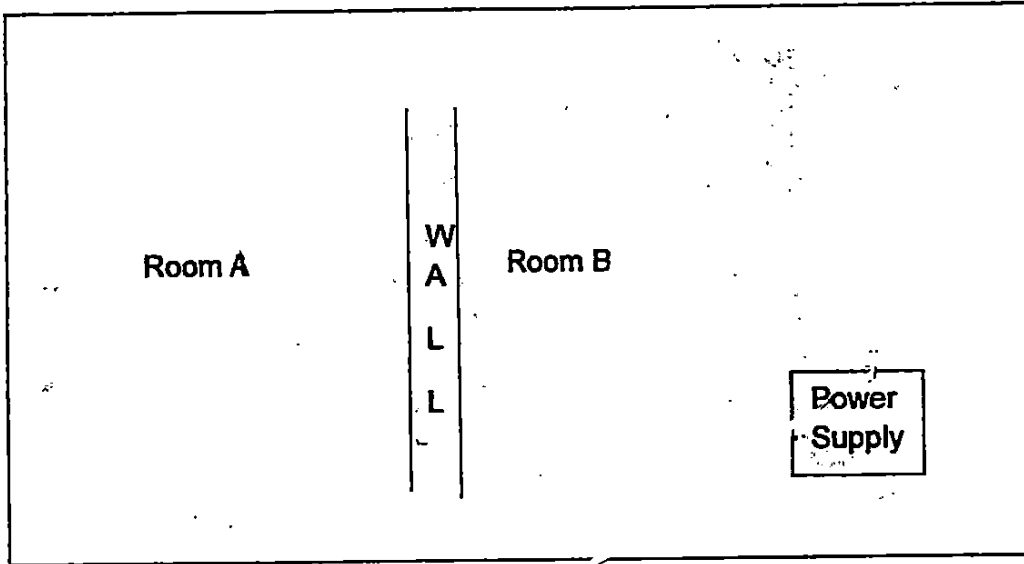

SCORE	2
-------	---

... and then put metal X into the beaker of boiling water for 20 minutes. After that, metal X was taken out of the boiling water and was transferred to a styrofoam cup which contained some water at 25°C.

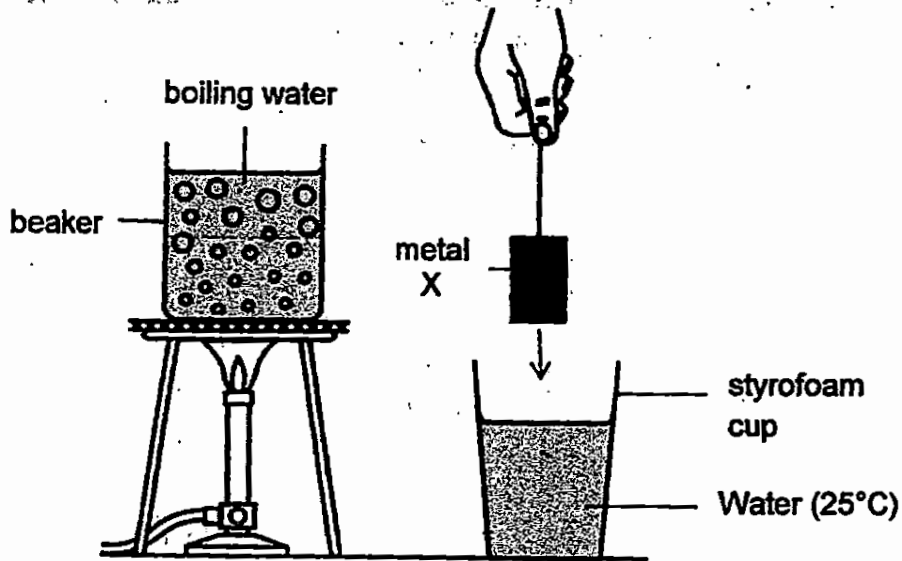

When metal X was immersed into the water in the styrofoam cup, the temperature of water in the styrofoam cup was recorded as shown below.

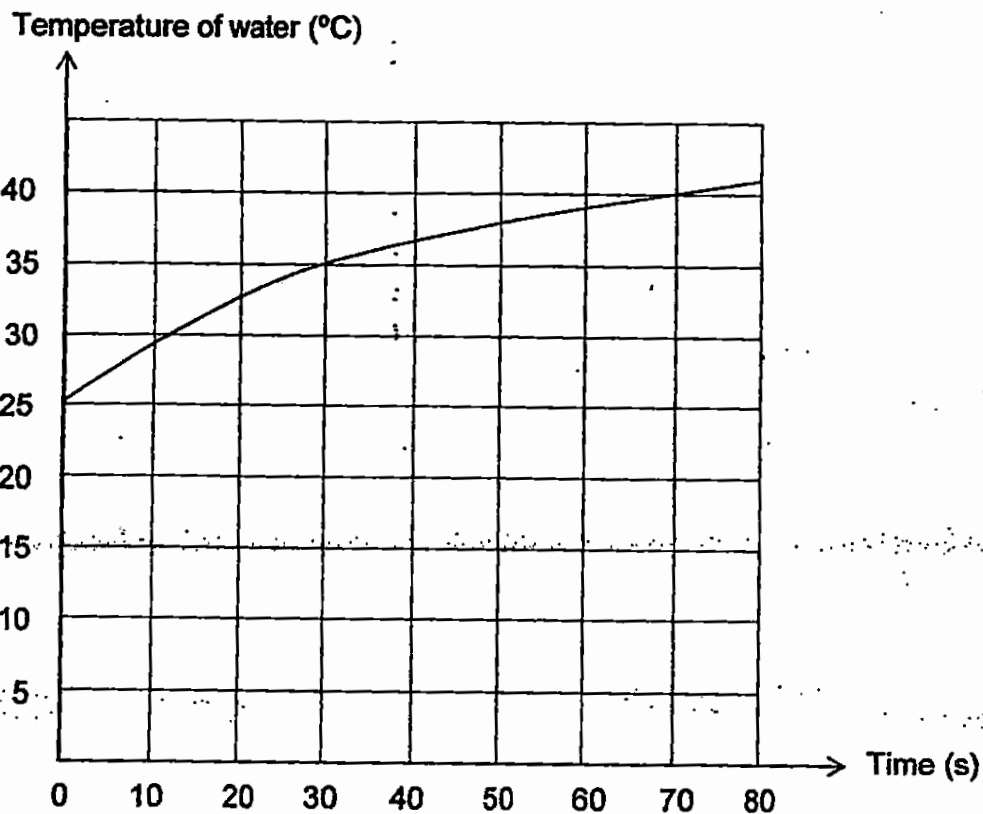

Continue on the next page

- (a) Based on the graph, what is the temperature of water in the styrofoam cup at the 30th second? [1]

\_\_\_\_\_

- (b) Explain the change in temperature of metal X when it was immersed in the boiling water and when it was immersed into the styrofoam cup respectively. [2]

In the boiling water: \_\_\_\_\_

\_\_\_\_\_

\_\_\_\_\_

In the styrofoam cup: \_\_\_\_\_

\_\_\_\_\_

\_\_\_\_\_

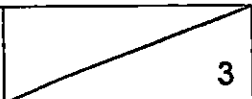
SCORE	
-------	---

The following experiment as shown in the diagram. A metal clip was tied to the table by a string of length 15 cm. When he clamped magnet R to the retort stand, the metal clip was suspended in the air.

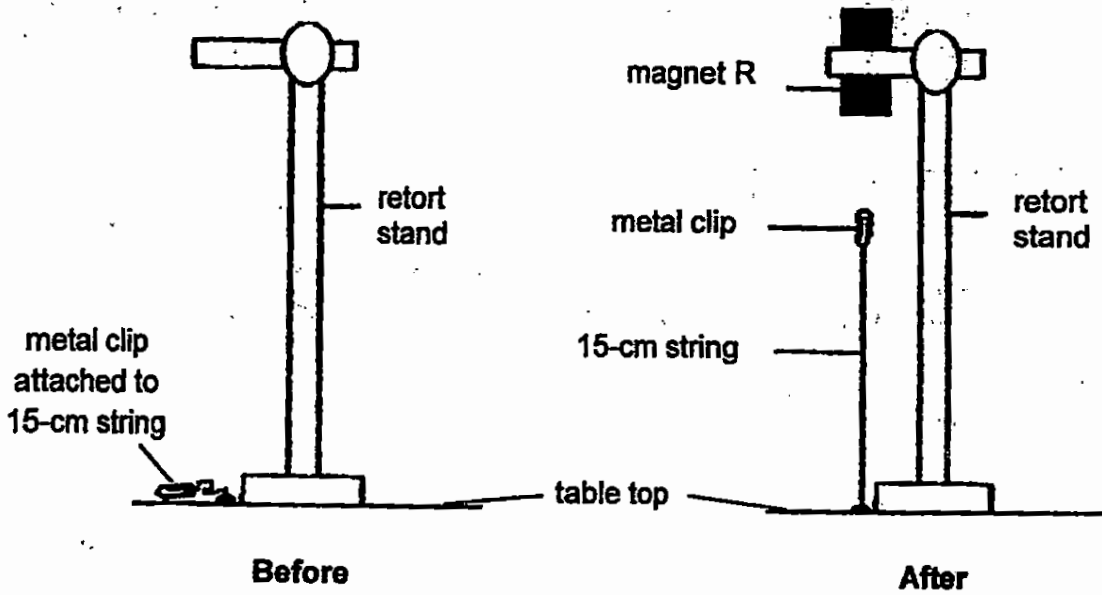

(a) Explain why the metal clip remained suspended in the air.

[1]

---

---

SCORE	1
-------	---

dropped unless he used a longer string of length 20 cm.

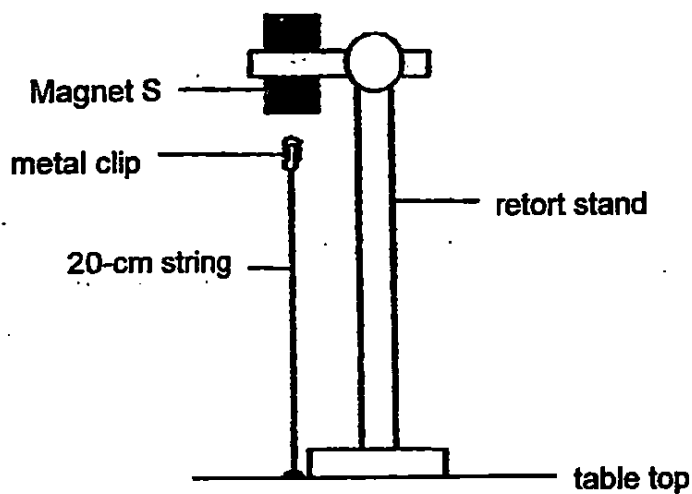

- (b) Give a reason why he had to use a longer string for the set-up with magnet S in order for the metal clip to be suspended in the air. [1]

Justin then placed a thin sheet of aluminium foil between magnet S and the suspended metal clip.

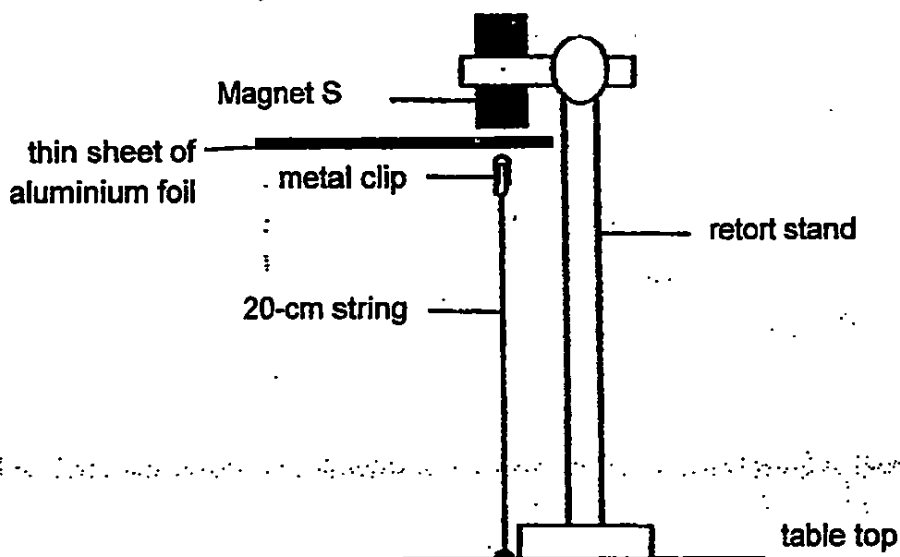

- (c) What would happen to the metal clip when Justin placed the thin sheet of aluminium foil between Magnet S and the paper clip? Explain your answer. [1]

- END OF PAPER -

SCORE	2
-------	---





**SCHOOL : RAFFLES GIRLS' PRIMARY SCHOOL**  
**SUBJECT : SCIENCE**  
**TERM : SA2**

Q 1	Q 2	Q 3	Q 4	Q 5	Q 6	Q 7	Q 8	Q 9	Q 10
4	3	2	2	3	3	4	3	4	2
Q 11	Q 12	Q 13	Q 14	Q 15	Q 16	Q 17	Q 18	Q 19	Q 20
1	2	1	4	3	3	4	1	2	2
Q 21	Q 22	Q 23	Q 24	Q 25					
2	3	3	2	4					

Q26a. A: egg

Q26a. B: sperm

Q26bi) Q

Q26bii) X

Q27a. Wind

Q27b. To ensure that his experiment to be reliable.

Q27c. The seed with wing – like structure took a longer time to reach the ground as the wing like structure allowed the seed to floating the air for a longer period of time than the seed without the wing – like structure.

Q28a. Green and Y

Q28b. Advantage - The stomata would be able to take in more air for a faster rate of gaseous exchange.

Q28b. Disadvantage – The stomata would have more water – loss.

Q29a. The gills will be able to take in more dissolved oxygen and remove more carbon dioxide during gaseous exchange in the gills.

Q29b. When the lady blew into the test tube, she blew in carbon dioxide, when carbon dioxide and limewater are in contact, the lime water will turn chalky, hence, the limewater turned chalky when the lady blew into the limewater.

Q30a. Cell X would have chloroplasts while Cell Y would not.

Q30b. Cell X came from leaves, leaves need to have chloroplast to trap sunlight to make food during photosynthesis. Y came from roots and roots do not need to make food, hence, cell Y would not.

Q30c. Cells X, Y and animal cells all have cytoplasm and cell membrane.

Q 31a. Lungs Q31b. There would be a higher amount of carbon dioxide in the blood flowing through blood vessels Y than X.

Q32aii) ✓ Q32aiii) ✓ Q32aiv) ✓ Q32av) ✓

it produces.

Q33a and Q33b. SEE PICTURE

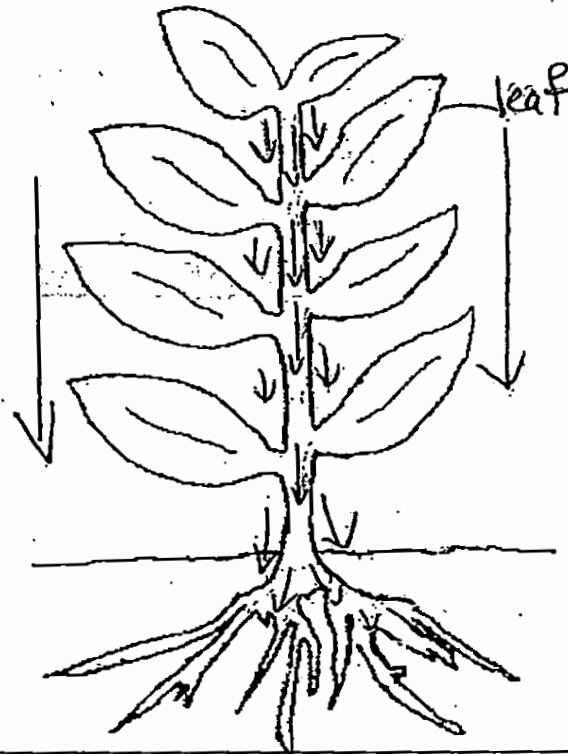

Q34a. SEE PICTURE

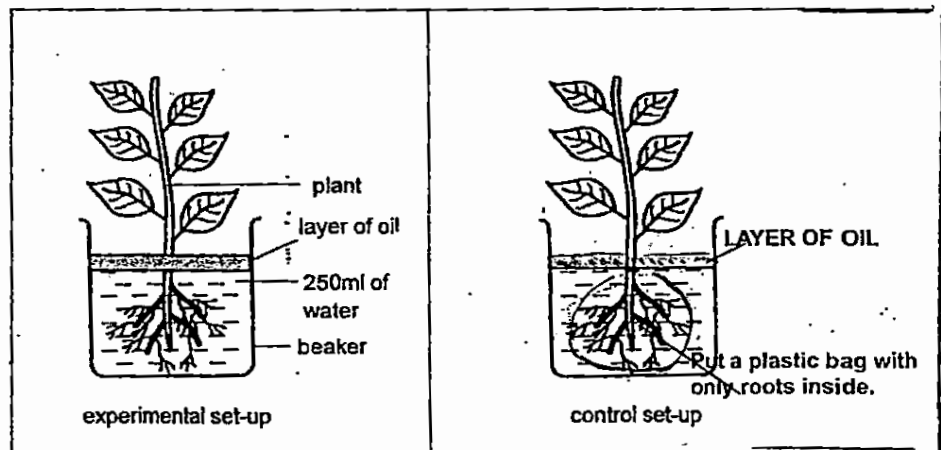

Q34b. It is to ensure that the only reason for water loss is by the roots;

Q34c. To prevent water in the beaker from evaporating.

Q35a. Some of the water in the container gained heat and evaporated into water vapor which escaped through the holes on the aluminum foil. Hence there would be lesser water vapour condensed on the underside of the aluminum foil in Y compared to X.



Q36a. SEE PICTURE

Q36b. B and D.

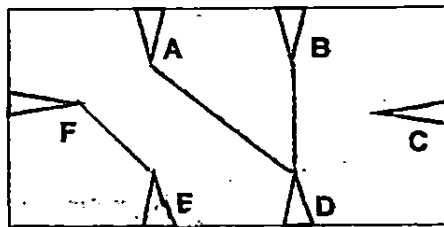

Q37a. (1) When one bulb fuses, the other bulb would not light up.

Q37a. (2) The bulbs would be dimmer.

Q37b. SEE PICTURE

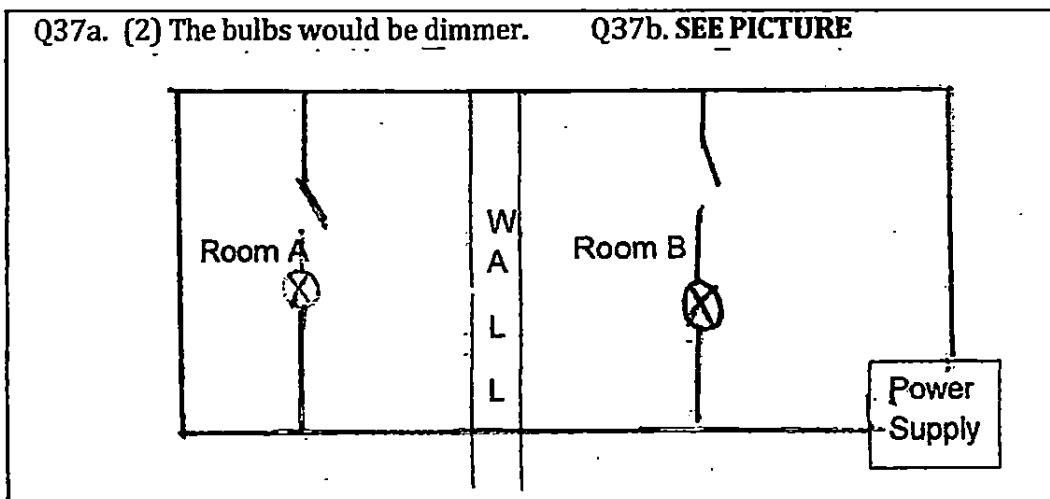

Q38a. 35°C

Q38b. In the boiling water : Metal X gained heat from the boiling water and increase in temperature.

Q38b. In the Styrofoam cup : Metal X lost heat to the water in the Styrofoam cup and decreased in temperature.

Q39a. The metal clip is magnetic and thus it is attracted to the magnet.

Q39b. Magnet R is a stronger magnet than S.

Q39c. The metal clip would remain the same. Aluminum is a non - magnetic material, hence, magnetism can pass it, hence, the metal clip will remain the same.

**THE END**

