



MAHA BODHI SCHOOL
2018 SEMESTRAL ASSESSMENT 2
PRIMARY THREE SCIENCE
(BOOKLET A)

Name : _____ ()

Class : Primary 3 _____

Date : 26 October 2018

Total Duration for Booklets A and B: 1 h 30 min

INSTRUCTIONS TO CANDIDATES:

1. Do not turn over this page until you are told to do so.
2. Follow all instructions carefully.
3. Answer all questions.
4. Shade your answers in the Optical Mark Sheet (OMS) provided.

This booklet consists of 14 printed pages.

BLANK PAGE

BOOKLET A : [22 x 2 marks = 44 marks]

For each question from 1 to 22, four options are given. One of them is the correct answer. Make your choice (1, 2, 3 or 4). **Shade your answer on the Optical Answer Sheet.**

1. A dog starts to bark when a stranger approaches.

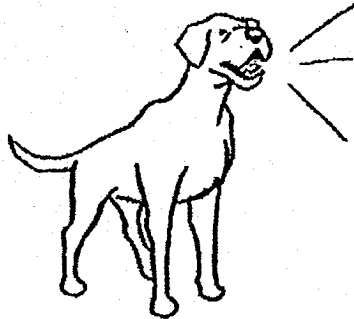

Which of the following characteristics of living things does the dog show?

- (1) Living things reproduce.
 - (2) Living things can make sounds.
 - (3) Living things respond to changes.
 - (4) Living things need air, food and water.
2. Plants which produce flowers are called flowering plants.
Which common characteristics of flowering plants listed below are correct?
- A. Some flowering plants bear fruits.
 - B. All flowering plants reproduce by spores.
 - C. Some flowering plants have stem, roots and leaves.
 - D. All flowering plants produce flowers when they become adult plants.
- (1) A and B
 - (2) A and D
 - (3) B and C
 - (4) C and D

3. Study the diagrams below.

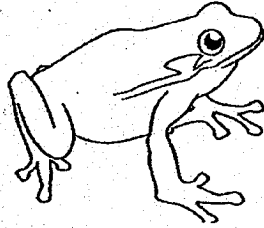

frog

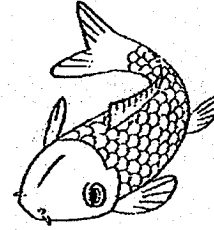

fish

Which of the following statements about the two living things are true?

- (1) Both have scales.
- (2) Both have gills and lungs.
- (3) Both reproduce by laying eggs.
- (4) Both breathe through their moist skin.

4. Study the diagrams below.

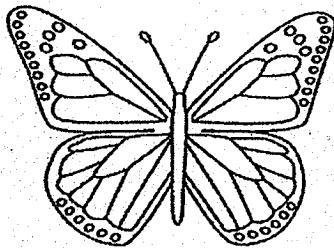

insect

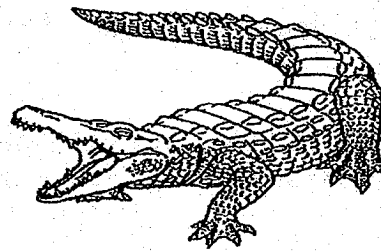

reptile

The insect and the reptile shown below are similar because both of them

- (1) lay eggs
- (2) have gills
- (3) have scales
- (4) have bodies divided in three parts

5. Which of the following best explains why the rotting log is important to the fungi growing on it?

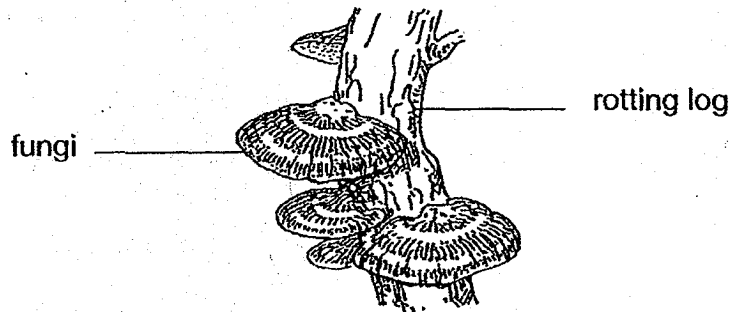

- (1) It gives shelter for the fungi.
 - (2) It provides food for the fungi.
 - (3) It helps the fungi to make food.
 - (4) It provides the fungi with more air.
6. Which of the following is a possible reason why glass is used to make the windows of a house?
- (1) It bends easily.
 - (2) It floats on water.
 - (3) It is non-magnetic.
 - (4) It allows light to pass through.
7. Siti put two materials, X and Y, into a basin of water and observed what happened. The diagram below shows her observation.

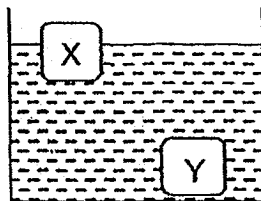

What property of material is she testing?

- (1) flexibility
- (2) strength
- (3) float or sink
- (4) waterproof or not waterproof

8. Aden labelled the poles of five identical bar magnets as A, B, C, D, E, F, G, H, J and K. He arranged the five magnets such that all five magnets were attracted as shown below.

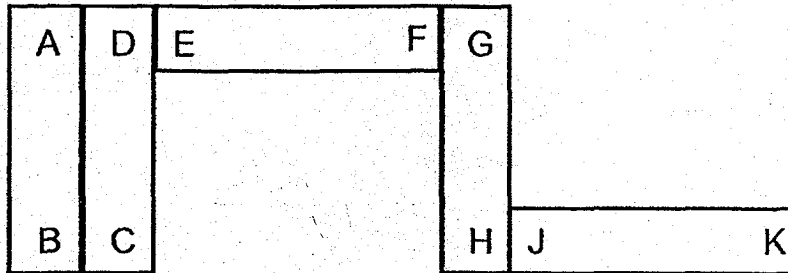

Which pair of magnets below shows the possible arrangement of two magnets being attracted to each other?

- (1)

A		B	K	J
---	--	---	---	---
- (2)

C		D	G	H
---	--	---	---	---
- (3)

B		A	E	F
---	--	---	---	---
- (4)

D		C	G	H
---	--	---	---	---

9. Which statement(s) below is/are true about magnets?

- A. All magnets are made of iron.
- B. All metals are attracted to magnets.
- C. Two magnets will always attract each other.
- D. A freely suspended magnet will come to rest in the North and South direction.

- (1) D only
- (2) B and C only
- (3) A and D only
- (4) A, B and C only

10. Which of the following is not a function of the skeletal system?

- (1) It supports the body.
- (2) It gives the body shape.
- (3) It transports food and water.
- (4) It protects organs in the body.

11. Which of the following human systems is correctly matched with its organs?

	System	Organs
(1)	respiratory	lungs, heart, nose
(2)	circulatory	blood vessels, heart
(3)	digestive	stomach, windpipe, small intestine
(4)	skeletal	skull, stomach, ribcage

12. Study the table below.

Living things	Non-living things
tiger	chair
water	table
bird's nest fern	pencil
banana tree	paper

Which of the following has been grouped incorrectly?

- (1) tiger
- (2) chair
- (3) water
- (4) banana tree

13. The table below shows the characteristics of objects A, B, C and D.

Objects	Able to move from place to place	Has eyes	Needs water	Can reproduce
A	Yes	Yes	Yes	Yes
B	Yes	No	Yes	Yes
C	Yes	Yes	No	No
D	No	No	Yes	Yes

Which of the following objects is a non-living thing?

- (1) Object A
- (2) Object B
- (3) Object C
- (4) Object D

14. The diagram below shows two living things, X and Y:

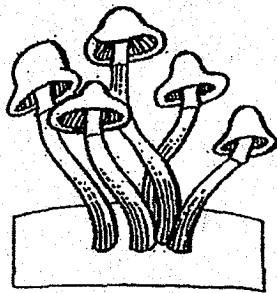

Living thing X

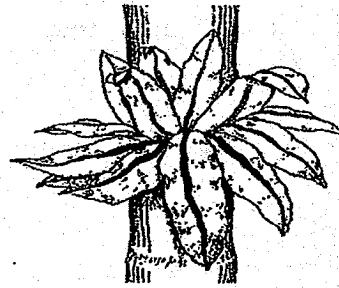

Living thing Y

Based on your observations, what are the similarities between living things X and Y?

- A. Both have gills.
 - B. Both make their own food.
 - C. Both reproduce by spores.
 - D. Both feed on other living things.
-
- (1) B only
 - (2) C only
 - (3) A and D only
 - (4) C and D only

15. Animals W, X, Y and Z below are grouped according to the way they reproduce.

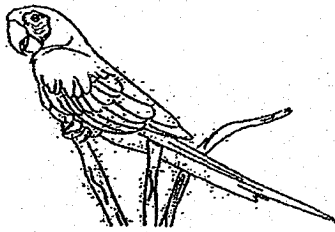

Animal W

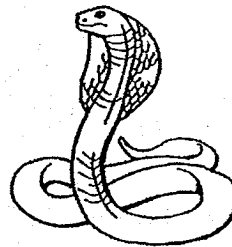

Animal X

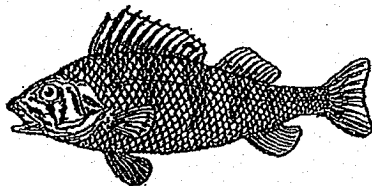

Animal Y

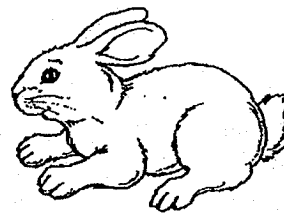

Animal Z

Based on your observations, which one of the following animals does **NOT** belong to the group?

- (1) Animal W
- (2) Animal X
- (3) Animal Y
- (4) Animal Z

16. Which of the following observations is correctly matched to the characteristics of living things?

	Observation	Characteristic
(1)	A fish swims away from danger.	Living things respond to changes.
(2)	A mammal gives birth to young alive.	Living things can grow.
(3)	An insect reproduces by laying eggs.	Living things need air, food and water.
(4)	A bird feeds on fruits on a plant.	Living things reproduce.

17. Suzie poured different amounts of water on Bread J and Bread K. She placed the two similar slices of bread J and K into two sealed bags. She then placed them in a dark cupboard. The diagrams below show what she observed after a few days.

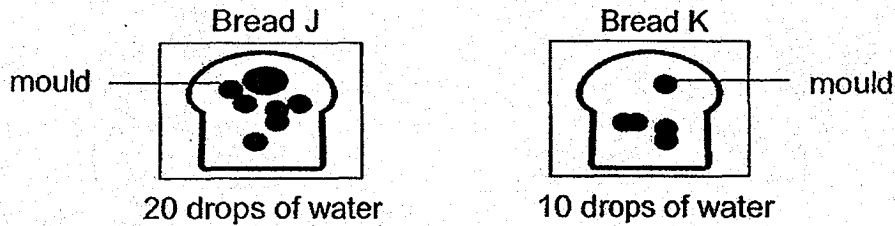

Based on the observation, which of the following statements is true of the mould?

- (1) The amount of air affects the growth of mould.
 - (2) The type of bread affects the growth of the mould.
 - (3) The amount of light affects the growth of the mould.
 - (4) The amount of water added affects the growth of the mould.
18. Study the flowchart below.

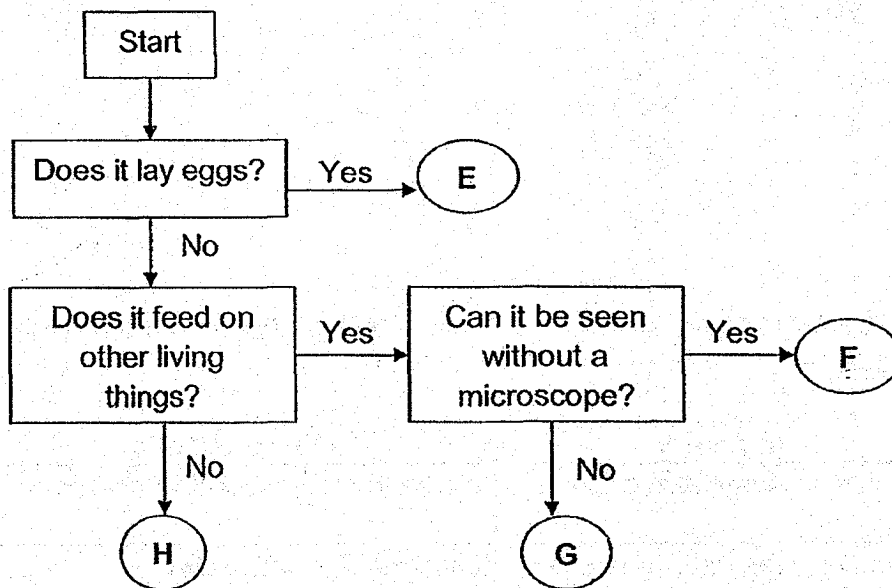

Which of these living things E, F, G or H represent fungi and bacteria?

	Fungi	Bacteria
(1)	H	F
(2)	E	H
(3)	F	G
(4)	G	H

19. The table below shows the properties of materials P, Q, R and S.

Material	Does it bend easily?	Does it break easily?	Does it absorb water?
P	Yes	Yes	No
Q	Yes	Yes	Yes
R	Yes	No	Yes
S	No	No	No

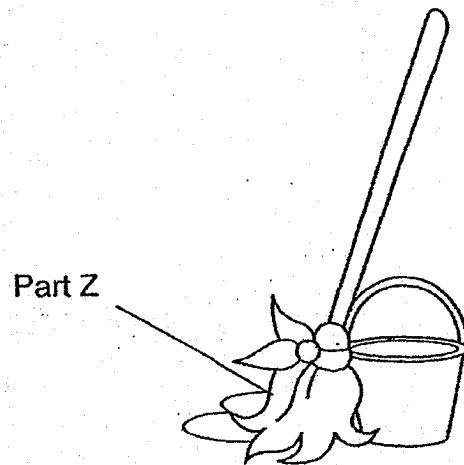

Based on the table above, which material would be most suitable to make Part Z of a mop?

- (1) P
- (2) Q
- (3) R
- (4) S

20. Study the flowchart below.

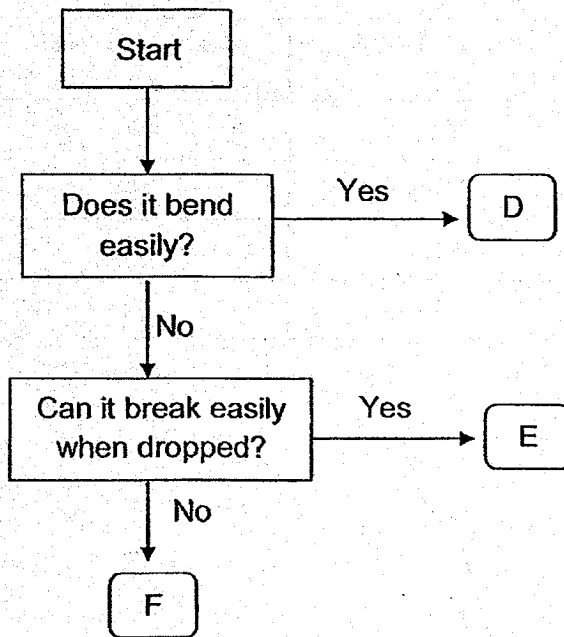

Based on the flow chart, which of the following could materials D, E and F be?

	D	E	F
(1)	fabric	metal	ceramic
(2)	fabric	ceramic	metal
(3)	metal	fabric	ceramic
(4)	metal	ceramic	fabric

21. Kenneth set up an experiment as shown below to compare the strength of four magnets J, K, L and M. He placed Magnet J, K, L or M at the 0 cm mark as shown below. He measured the furthest distance, d , that the Bar Z repelled.

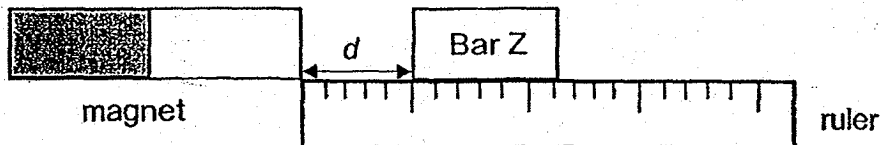

He recorded his results in the table below.

Magnet	Distance that the Bar Z was repelled (d) / cm
J	1
K	2
L	3
M	5

Based on his results, which of the following conclusions are correct?

- A. Magnet J is the strongest.
 - B. Magnet J is weaker than magnet M.
 - C. Magnet L is stronger than magnet K.
 - D. Magnet K is stronger than J but weaker than M.
- (1) A and B only
(2) B and D only
(3) B, C and D only
(4) A, B, C and D

22. The diagram below shows a boy jogging.

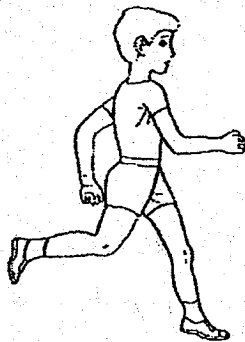

Which of the following human systems work together when the boy is jogging?

- A. Digestive system
- B. Skeletal system
- C. Muscular system
- D. Circulatory system
- E. Respiratory system

- (1) A and B only
- (2) A, C and D only
- (3) C, D and E only
- (4) A, B, C, D and E

END OF BOOKLET A

GO ON TO BOOKLET B



MAHA BODHI SCHOOL
2018 SEMESTRAL ASSESSMENT 2
PRIMARY THREE SCIENCE
(BOOKLET B)

Name : _____ ()

Class : Primary 3 _____

Date : 26 October 2018

Total Duration for Booklets A and B: 1 h 30 min

INSTRUCTIONS TO CANDIDATES:

1. Do not turn over this page until you are told to do so.
2. Follow all instructions carefully.
3. Answer all questions.
4. Write all your answer in this booklet.

Booklet	Marks Obtained	Max Marks
A		44
B		28
Practical Test		8
Total		80

Parent's signature:

This booklet consists of 10 printed pages.

BLANK PAGE

BOOKLET B : [28 marks]

For questions 23 to 30, write your answers in this booklet.

The number of marks available is shown in the brackets [] at the end of each question or part-question.

23. Ahmad placed 500g of food and 500ml of water into two similar glass tanks. He then placed a live mouse into one of the tanks and a toy mouse in the other as shown below. He then covered the glass tanks with a plastic cover. He recorded the amount of food and water left in both tanks after one day.

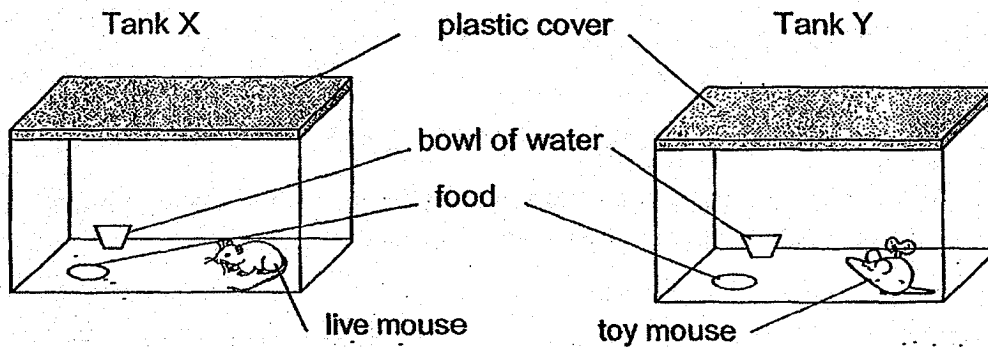

- (a) In the table below, write 'X' or 'Y' in the correct boxes to show the amount of food and water left after a few hours. [1]

Tank	Amount of food left (g)	Amount of water left (ml)
(i)	500	500
(ii)	400	320

- (b) The mouse in one of the tanks died after a day even though there was still food and water left. Explain how Ahmad could prevent the mouse from dying. [1]

Marks : / 2

24. Sam saw a potted plant X in the garden as shown below.

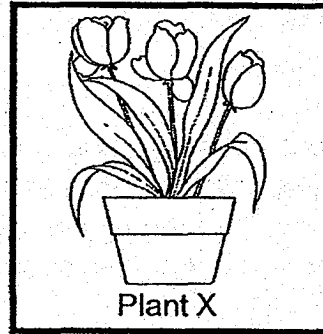
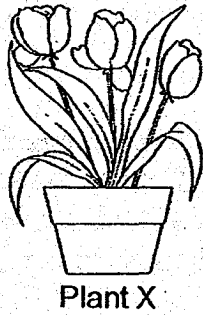

(a) Which group of plants does Plant X belong to? [1]

(b) Sam said that all plants which bear fruits are non-flowering plants. Do you agree with his statement? Explain your answer. [1]

(c) Sam placed Plant X in a sealed black box as shown above. Two weeks later, he observed that plant X had died. Give a reason and explain why. [2]

Marks :

/ 4

25. Study the flowchart below carefully.

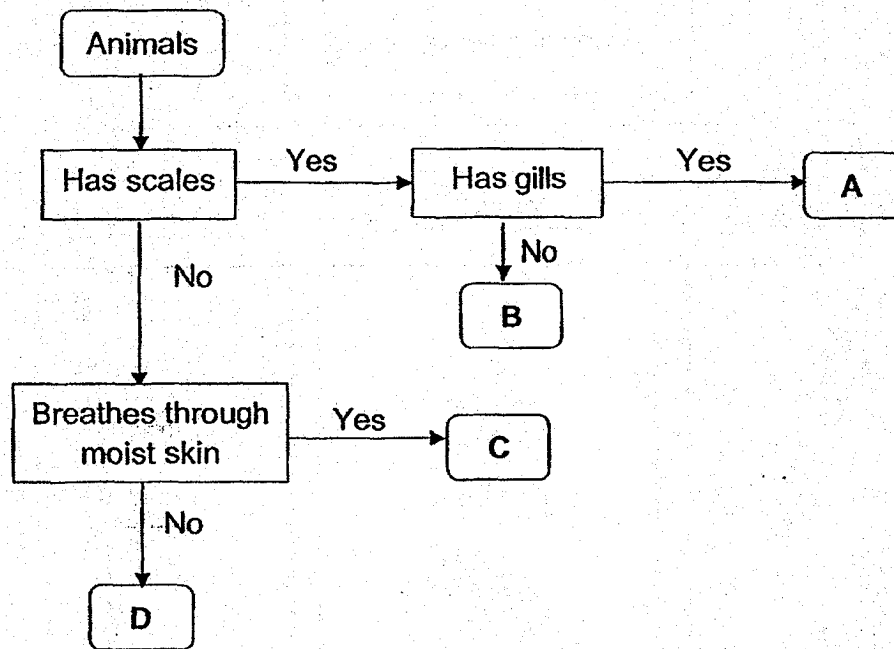

(a) Based on the above flowchart, write the letters A, B, C and D that represent the following animal groups. [2]

(i) Fish

(ii) Reptile

(iii) Mammal

(iv) Amphibian

(b) Based on the flowchart, state all the characteristics of animal A. [1]

Marks :

/ 3

26. Study the three groups of animals in the classification table below.

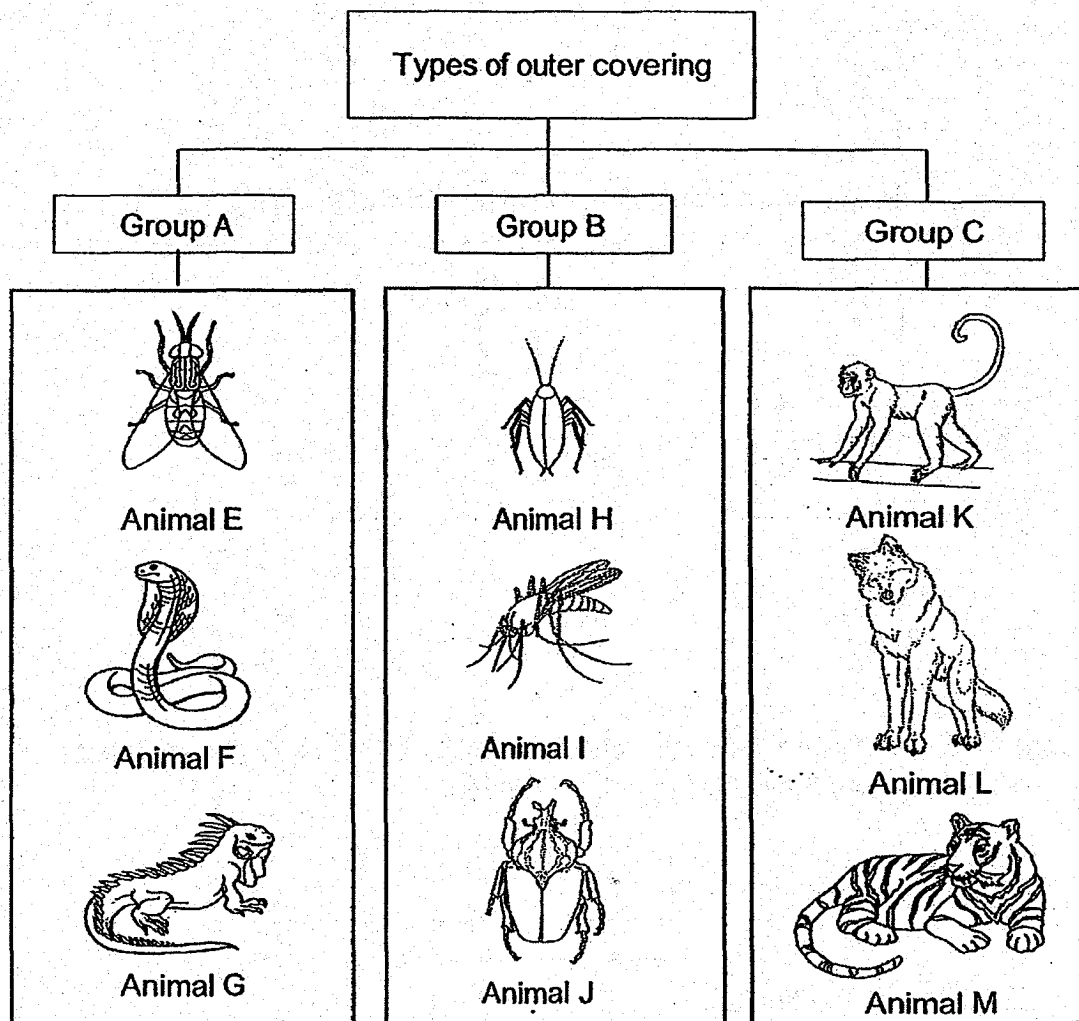

(a) Give a suitable heading for group B. [1]

(b) Animal E is grouped wrongly.
 Explain why Animal E is grouped wrongly. [2]

Marks :

/ 3

27. Peter tested 4 materials D, E, F and G, as shown below. He hung a 30g weight at the end of each material and measured the distance 'd'.

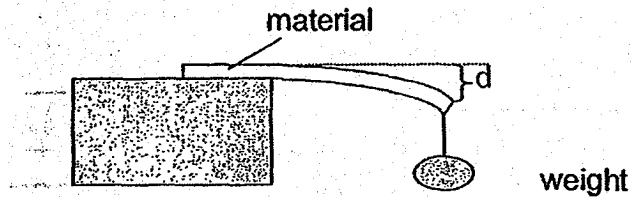

He recorded the results in the table below.

Material	d (cm)
D	25
E	10
F	2
G	8

- (a) What property of material is being tested? [1]
- _____
- (b) Which material should Peter choose to make a tray for serving drinks? Explain your answer. [2]
- _____
- _____
- (c) List two other properties of the material chosen in (b) should have to make the tray. [1]

Property 1: _____

Property 2: _____

Marks :

/ 4

28. The diagram below shows the human digestive system.

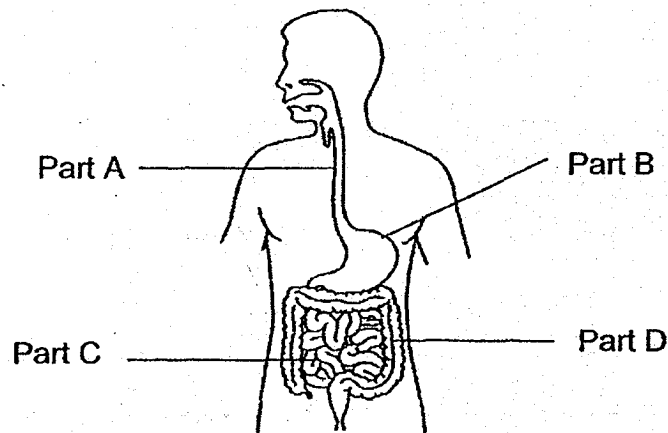

(a) Identify the parts A, B, C and D of the human digestive system. Write the letters A, B, C and D in the boxes below. [2]

- (i) large intestine
- (ii) small intestine
- (iii) stomach
- (iv) gullet

(b) Thomas choked on his food when he did not chew his food long enough. Explain how chewing and saliva help in digestion of food. [2]

Marks : / 4

29. Joan conducted an experiment using the set-up shown below with a new battery, a piece of wire and an iron nail.

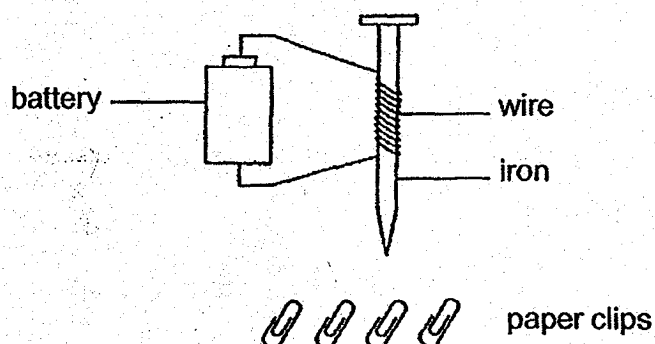

When she placed some paper clips near the iron nail, she observed that they were attracted to the iron nail.

- (a) Explain why the paper clips were attracted to the iron nail. [1]

- (b) What would happen to the paper clips if Joan removed the batteries completely from the set-up? [1]

Joan added more batteries to the set up and recorded her observation in the table below.

Number of batteries	Number of paper clips attracted
1	9
2	11
3	15

- (c) From the results shown in the table above, what is the relationship observed between the number of batteries and the strength of the magnet? [2]

Marks : / 4

30. Benson used three ring magnets, T, U and V, to set up an experiment as shown below. He observed the interactions between the three ring magnets as shown below.

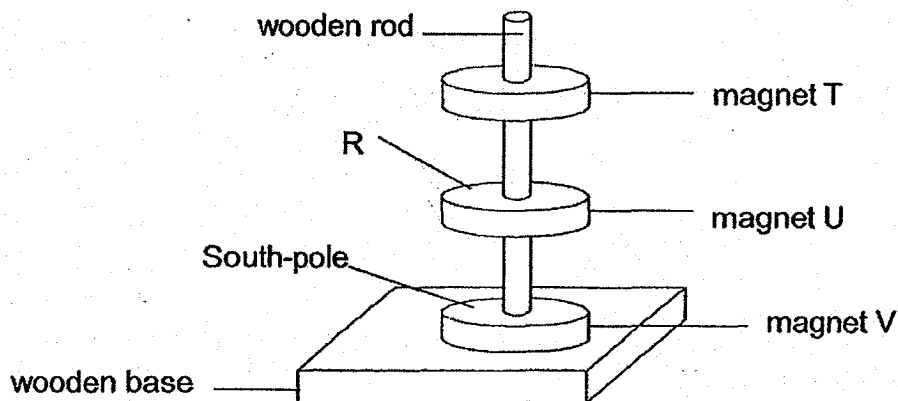

- (a) (i) Identify the pole labelled R on magnet U. [1]

- (i) Explain how ring magnets T, U and V were able to stay afloat. [1]

- (b) (i) Ring magnet T was changed to a plastic ring. What will happen to the plastic ring? [1]

- (ii) Explain your answer in (bi). [1]

Marks : / 4

~ END OF PAPER ~

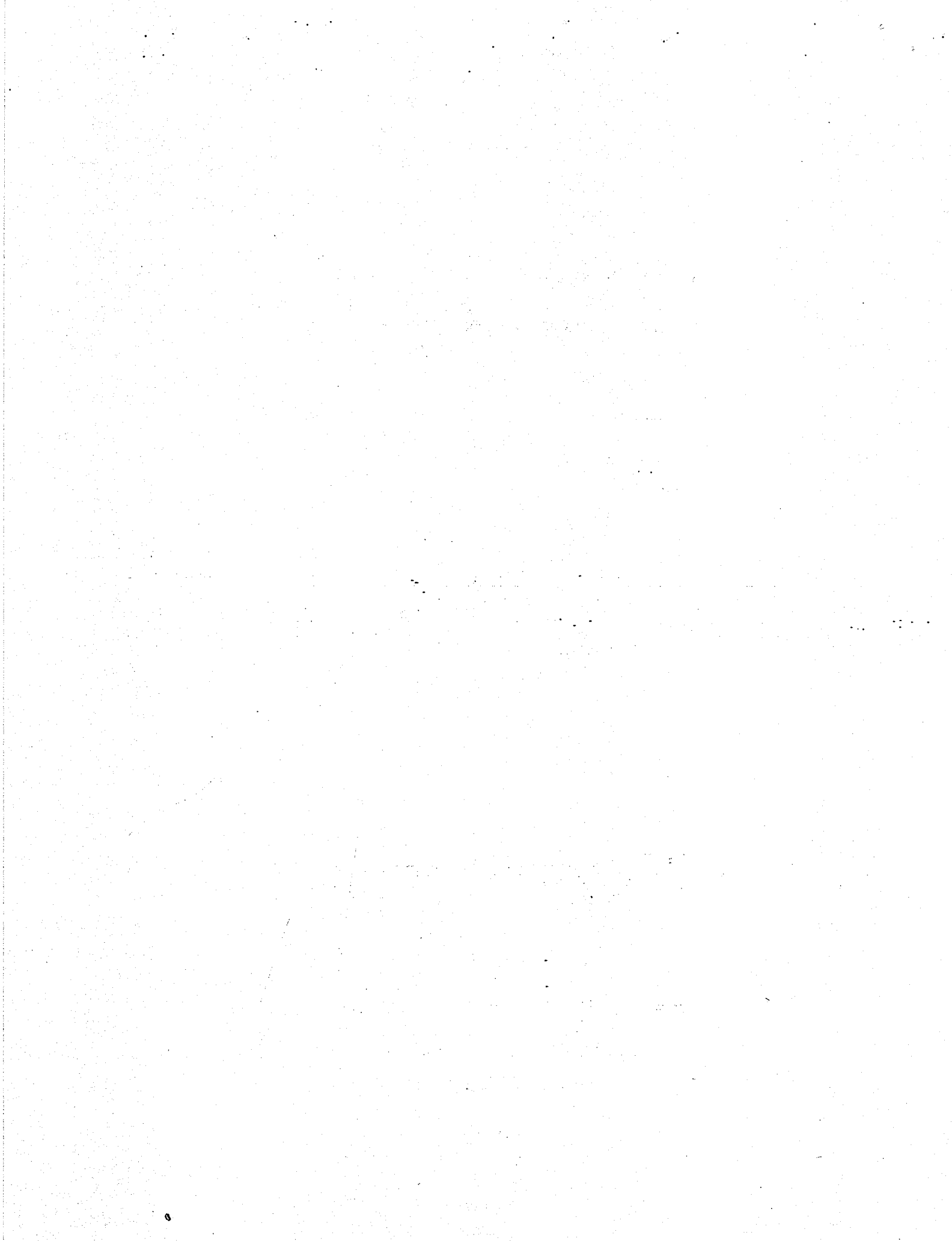

EXAM PAPER 2018 (P3)

SCHOOL : MAHA BODHI

SUBJECT : SCIENCE

TERM : SA2

Q1	Q2	Q3	Q4	Q5	Q6	Q7	Q8	Q9	Q10
3	2	3	1	2	4	3	2	1	3
Q11	Q12	Q13	Q14	Q15	Q16	Q17	Q18	Q19	Q20
2	3	3	2	4	1	4	3	3	2
Q21	Q22								
3	4								

Q23) a) (i) Y

(ii) X

b) Change the plastic cover to a cover with holes. He could poke some holes in the lid to allow air to enter the tank.

Q24) a) Flowering plants

b) No. I do not agree with his statement because non-flowering plants do not bear flowers and if there's no flowers, there's no fruit.

c) There's no sunlight but plants need sunlight to make food, so the plant cannot stay alive.

Q25) a) (i) A

(ii) B

(iii) D

(iv) C

b) Animal A have scales and gills.

Q26) a) Exoskeleton

b) Group A consists of reptiles only but Animal E is an insect.

Q27) a) Flexibility

b) Material F. It is the stiffest material and trays need to be stiff to hold drinks.

c) Property 1 : Waterproof

Property 2 : Strong

Q28) a) (i) D

(ii) C

(iii) B

(iv) A

b) Chewing helps to break down the food into smaller pieces and saliva helps to soften the food.

Q29) a) The iron nail became a temporary magnet.

b) Drop

c) The more the number of batteries, the stronger the strength of the magnet.

Q30) a) (i) North-pole

(ii) The like poles of magnet T, U, V were facing each other, so they repelled to stay afloat.

b) (i) Rest on magnet U

(ii) A plastic ring is not a magnetic material so it will not be able to repel.

