



2018 PRIMARY 3 SEMESTRAL ASSESSMENT 2

Name : _____ ()

Date: 22 October 2018

Class : Primary 3 ()

Time: 8.00 a.m. - 9.30 a.m.

Parent's Signature: _____

Duration: 1 hour 30 minutes

SCIENCE

BOOKLET A

INSTRUCTIONS TO CANDIDATES

1. Write your name, class and register number.
2. Do not turn over this page until you are told to do so.
3. Follow all instructions carefully.
4. Answer all questions.
5. Shade your answers on the Optical Answer Sheet (OAS) provided.

Booklet A (22 x 2 marks)

For each question from 1 to 22, four options are given. One of them is the correct answer. Make your choice (1, 2, 3 or 4) and shade your answer on the Optical Answer Sheet. (44 marks)

1. Which of the following shows the correct examples of living things and non-living things?

	Living things	Non-living things
(1)	Cat	Fish
(2)	Tree	Lamp
(3)	Vase	Table
(4)	Grass	Bread mould

2. Mary set up four jars, A, B, C and D, as shown below.

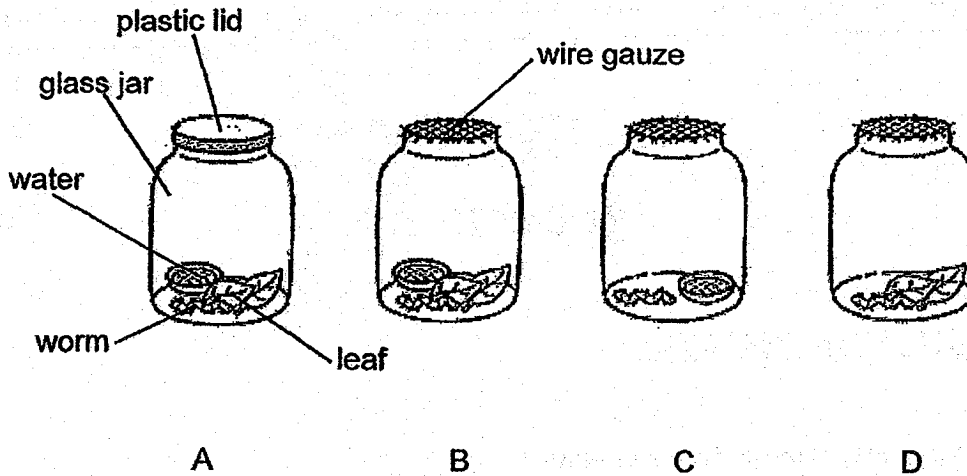

Which two set-ups should Mary use to find out whether living things need water to survive?

- (1) A and B
(2) A and C
(3) B and D
(4) C and D

3. Ravi watched a snail in his garden. He touched it gently and observed that the snail moved into its shell immediately.

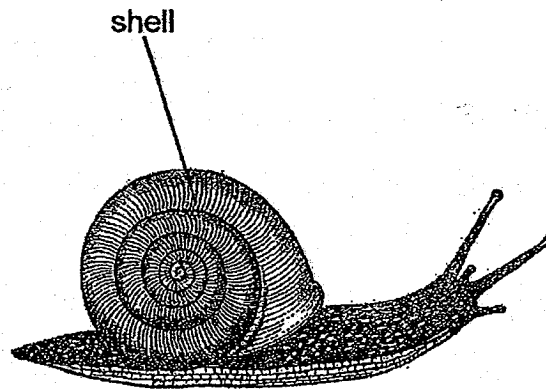







Which characteristic of living things did the snail display?

- (1) Living things can die.
- (2) Living things can grow.
- (3) Living things respond to changes around them.
- (4) Living things need air, food and water to survive.

4. Susan wanted to find out what A and B are. She placed A and B each in a brightly lit room on Day 1 with a daily supply of water. 500g of leaves was placed in each room on the first day. On Day 4, she measured the amount of leaves left. Her readings are shown in the table below.

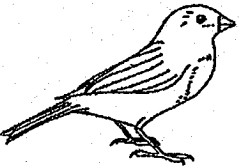
	A	B
Amount of food given on Day 1 (g)	500	500
Amount of food left on Day 4 (g)	500	100

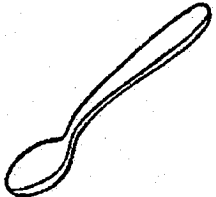
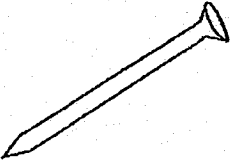
Which of the following could A and B be?

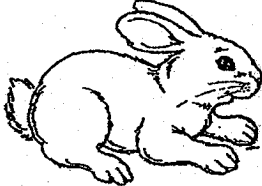
	A	B
(1)	 A towel	 A hamster
(2)	 A bird	 A laptop
(3)	 A spoon	 A nail
(4)	 A goat	 A rabbit

5. The diagram below shows the classification of living things.

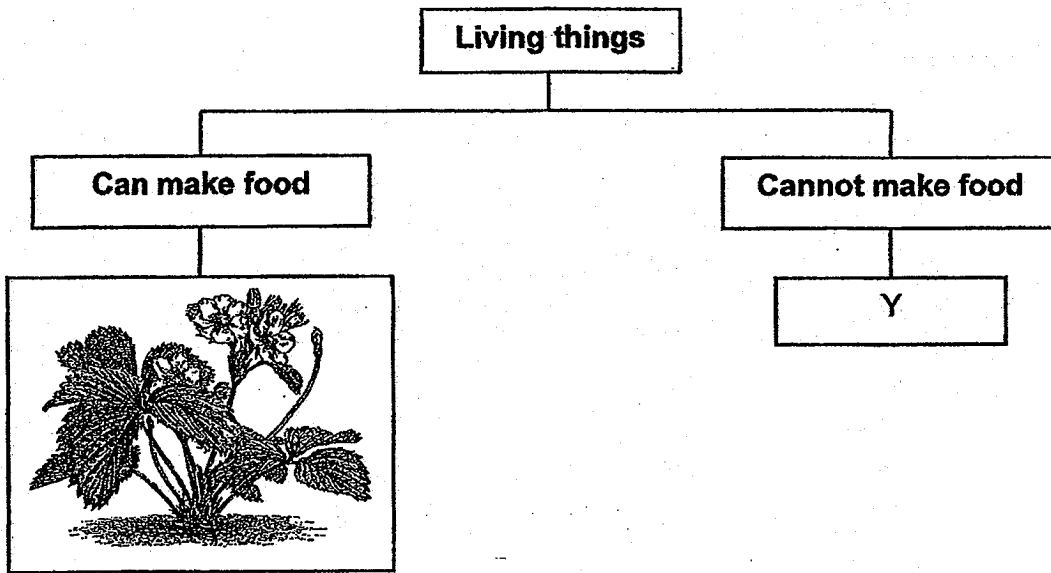

Which of the following could Y be?

(1)

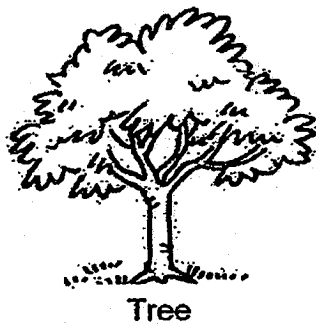

(2)

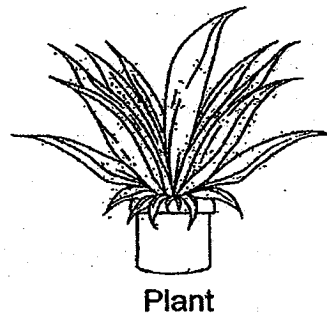

(3)



(4)



6 Study the flow chart below.

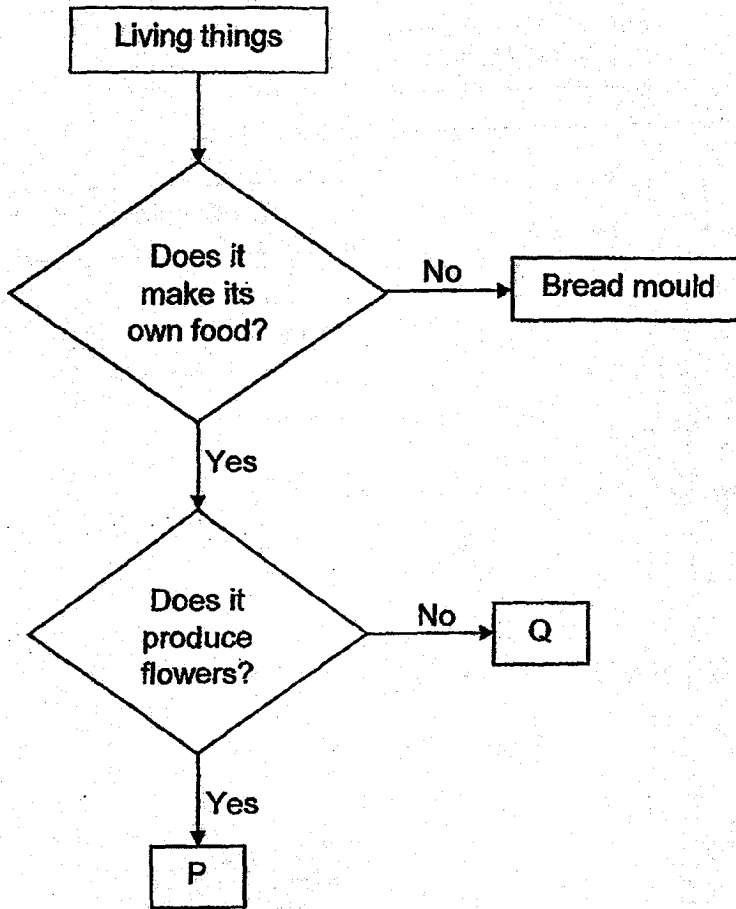

Which of the following best describe P and Q?

	P	Q
(1)	P is a plant.	Q is an animal.
(2)	P has leaves.	Q does not have leaves.
(3)	P needs sunlight to survive.	Q does not need sunlight to survive.
(4)	P bears fruits.	Q does not bear fruits.

7. Study the animals below.

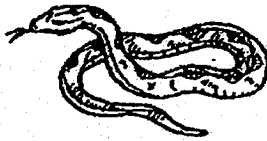

Snake



Fish



Crocodile

What do these animals have in common?

- (1) They have scales.
- (2) They have four legs.
- (3) They swim using their fins.
- (4) They give birth to their young alive.

8. Study the classification chart below.

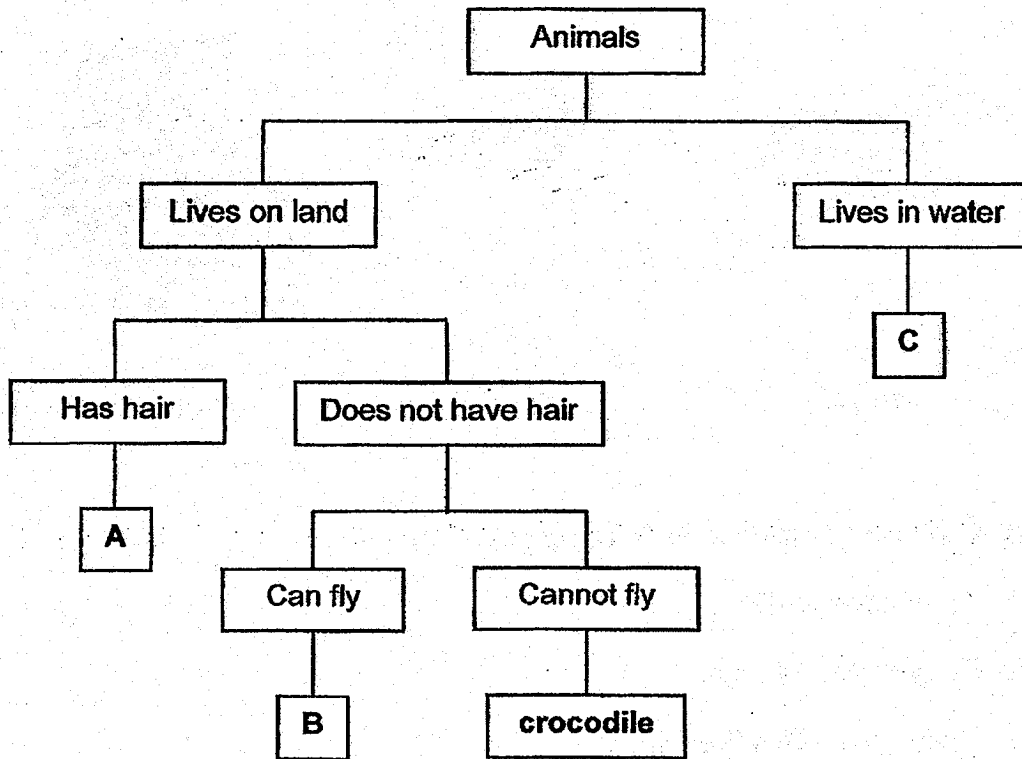

What do A, B and C represent?

	A	B	C
(1)	dog	eagle	goldfish
(2)	eagle	goldfish	butterfly
(3)	dog	butterfly	eagle
(4)	butterfly	dog	goldfish

9. The table below shows some information on four plants, A, B, C and D. A tick (✓) shows that the characteristic is present in that plant.

Plant	Characteristics		
	Has fruits	Can make its own food	Grows on land
A			
B			
C			
D			

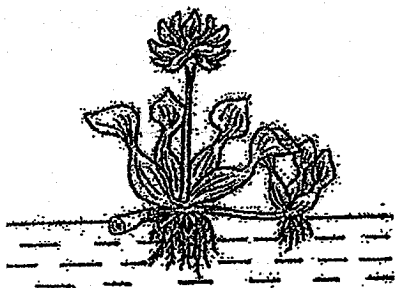

The plant shown in the diagram above has similar characteristics as _____.

- (1) A
- (2) B
- (3) C
- (4) D

10. Study the plant shown below.

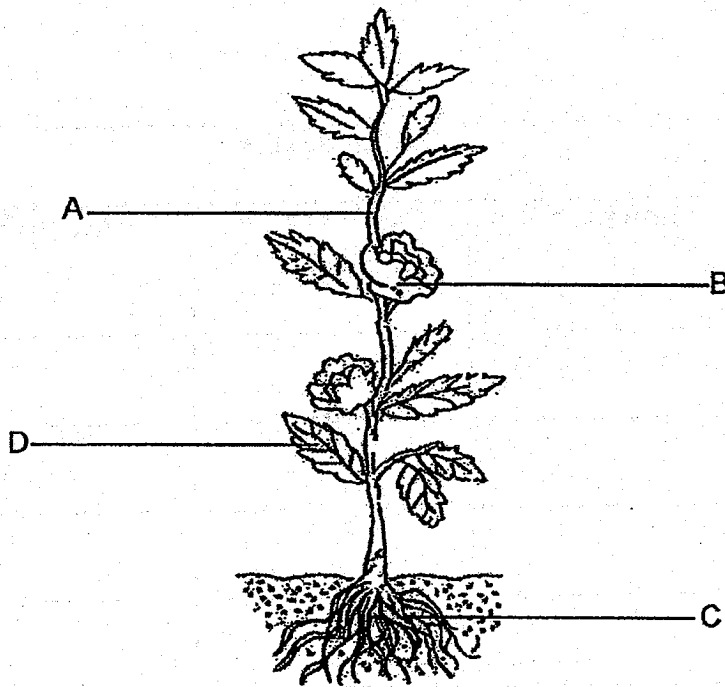

Which plant part shown above, A, B, C or D, supports the plant?

- (1) A
- (2) B
- (3) C
- (4) D

11. The diagram below shows a coconut tree.

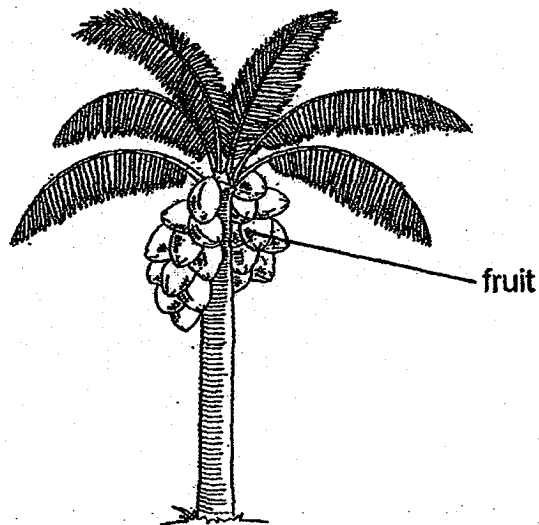

Based on the above diagram, which of the following is true about the coconut tree?

- (1) It is a flowering plant with a weak stem.
- (2) It is a flowering plant with a strong stem.
- (3) It is a non-flowering plant with a weak stem.
- (4) It is a non-flowering plant with a strong stem.

12. Wendy placed 4 similar plants in the set ups as shown below. She watered the plants daily with the same amount of water.

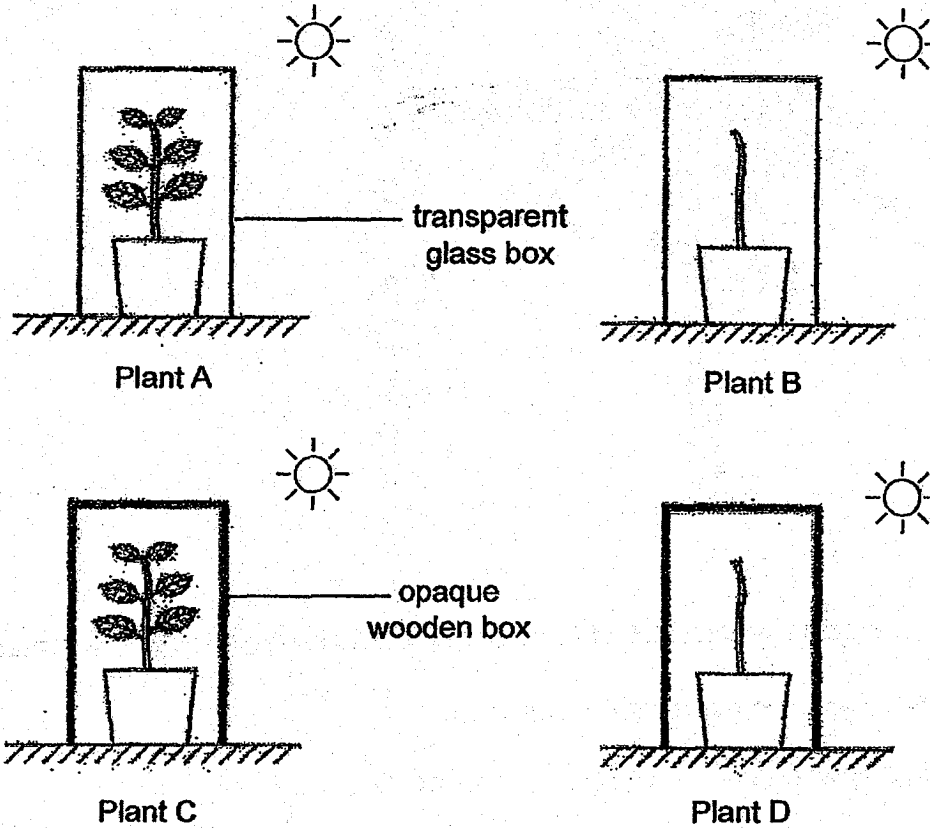

Which plant is most likely to continue growing after 1 month?

- (1) Plant A
- (2) Plant B
- (3) Plant C
- (4) Plant D

13. Sean is running with his net to catch a butterfly immediately after a meal.

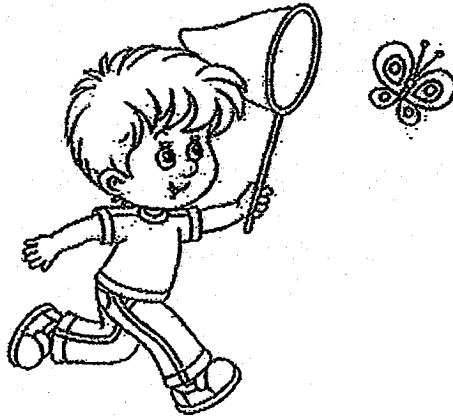

Which organ systems in Sean's body are working together when he is catching the butterfly?

- A Skeletal system
- B Digestive system
- C Circulatory system
- D Respiratory system

- (1) B and C
- (2) C and D
- (3) A, B and D
- (4) A, B, C and D

14. Sarah's grandmother has lost most of her teeth but she still needs to eat her food. What will most likely happen to the food that she has taken as compared to her having her full set of teeth?

- (1) The food cannot be digested at all.
- (2) The food cannot be absorbed at all.
- (3) The food will take a longer time to digest.
- (4) The food can be chewed into smaller pieces.

15. Study the diagram of the human digestive system below.

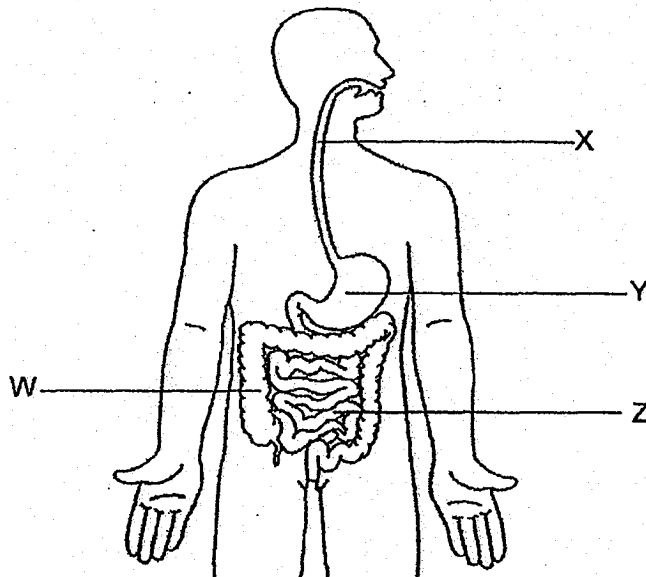

In the human digestive system, which parts do not contain digestive juices?

- (1) W and X
- (2) W and Z
- (3) X and Y
- (4) Y and Z

16. The diagram below shows a pair of reading spectacles.

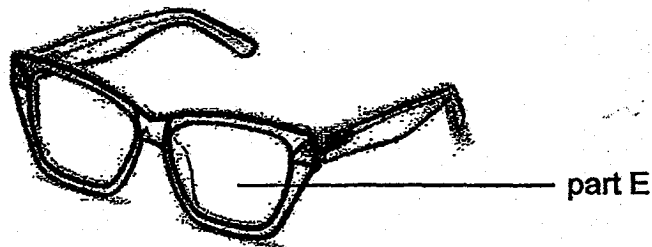

Which is the most important property to consider when selecting a suitable material to make part E?

- (1) It is light.
- (2) It can bend easily.
- (3) It does not break easily.
- (4) It allows most light to pass through it.

17. The table below shows the properties of three materials, P, Q and R. A tick (✓) shows that the property is present.

Properties	Materials		
	P	Q	R
Flexible			
Absorbent to water			
Allows light to pass through			

Based on the information given in the table above, what would P, Q and R most likely be?

	P	Q	R
(1)	rubber	steel	fabric
(2)	clear glass	fabric	steel
(3)	clear glass	steel	rubber
(4)	rubber	fabric	clear glass

18. Benjamin set up an experiment as shown below. He decided to test the strings of different materials that are of similar length and thickness. He added weights, of equal mass, onto the pan until the string broke. His results were shown in the table below.

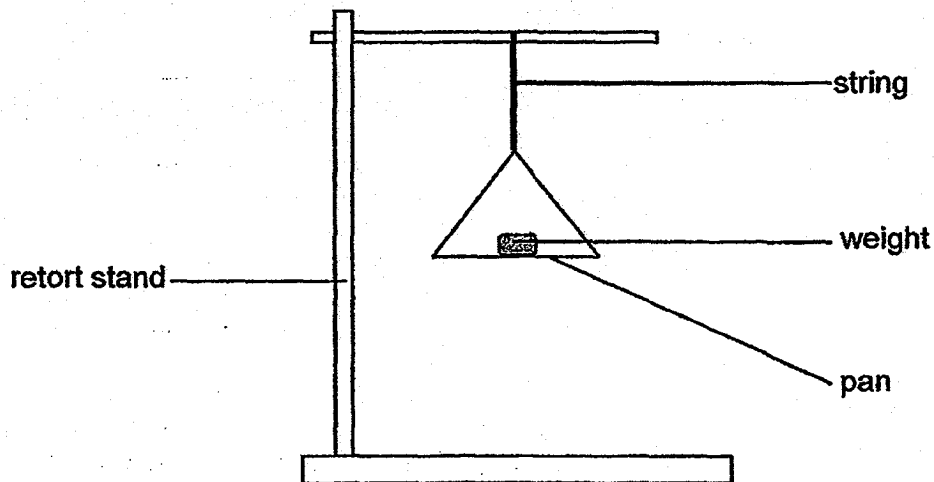

	A	B	C	D
Number of 10 g weights added before the string broke	3	8	9	10

From the table above, which string A, B, C or D, would be able to hang a 95g lantern from the ceiling without breaking?

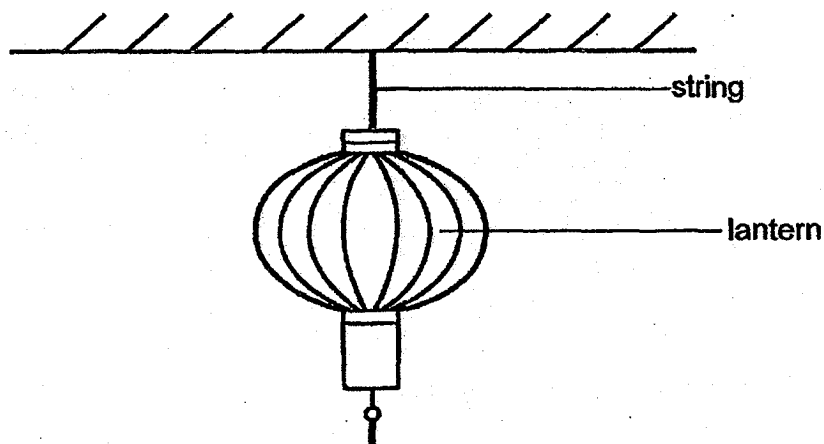

- (1) A
- (2) B
- (3) C
- (4) D

19. Alice lowered the bar magnet below into a container filled with iron pins.

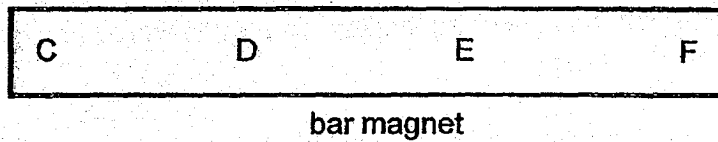

Which parts of the magnet are likely to attract the most number of iron pins?

- (1) C and D
 - (2) C and F
 - (3) D and E
 - (4) E and F
20. Ken displayed a poster on the class noticeboard using a magnet as shown below.

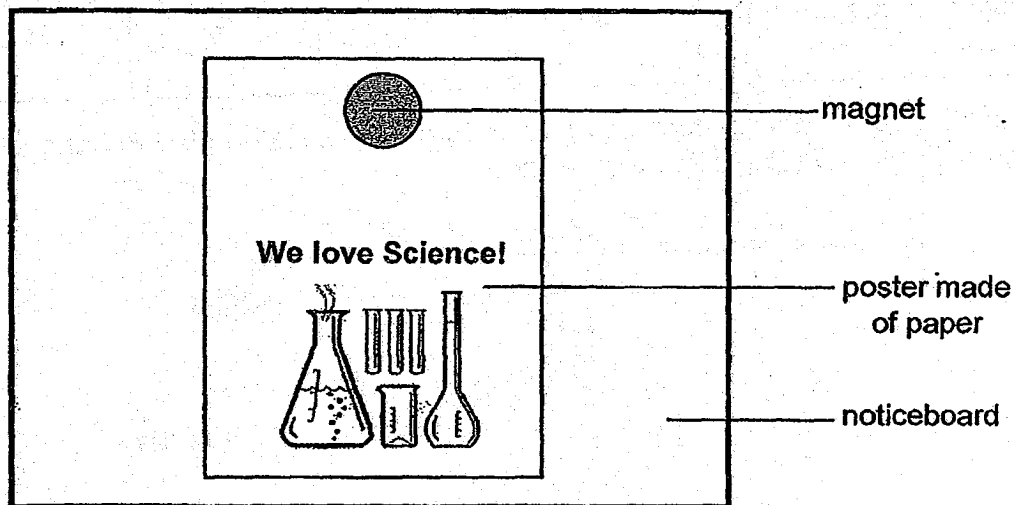

What material is the noticeboard made of?

- (1) iron
- (2) gold
- (3) wood
- (4) plastic

21. Four bar magnets can be arranged as shown below. Their poles are P, Q, T, U, V, W, X and Y.

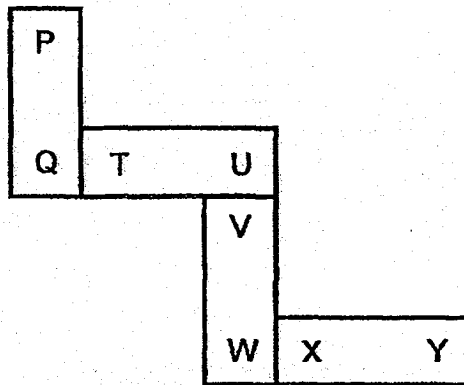

Which is another possible arrangement of the magnets?

(1)

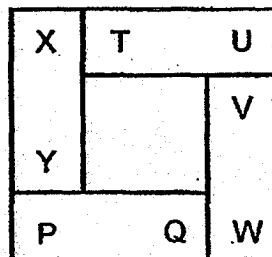

(2)

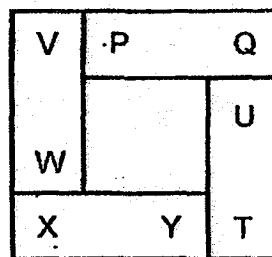

(3)

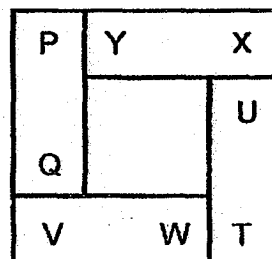

(4)

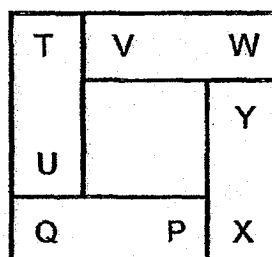

22. Juliana prepared the set-up below. When the tray of needles was brought near to the iron nail, ten needles were attracted to the iron nail.

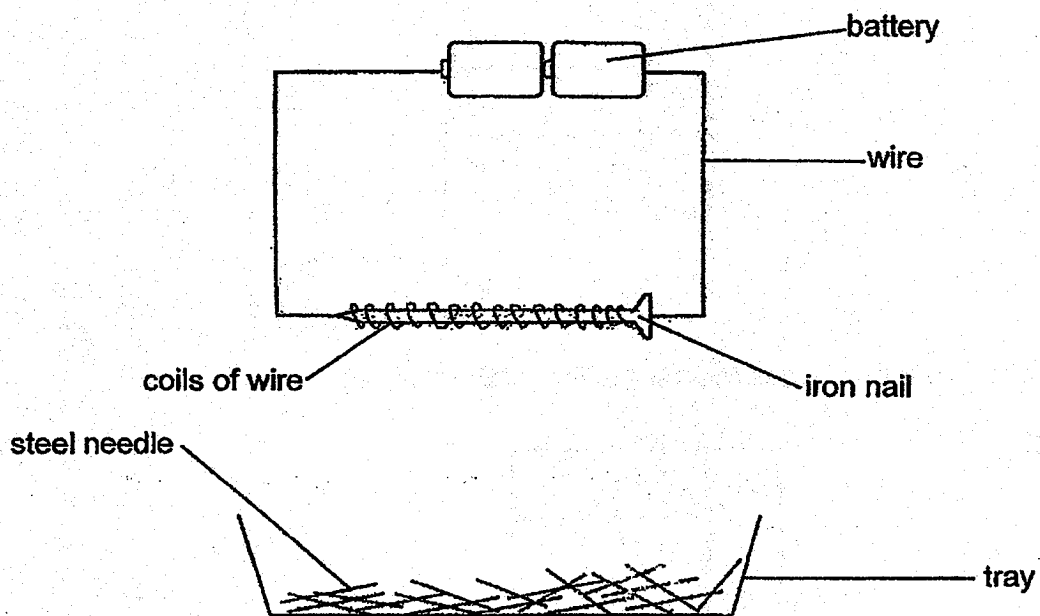

What change can she make to the set-up so that the nail can attract more needles?

- (1) Increase the number of batteries
- (2) Change the iron nail to an aluminium nail
- (3) Change the steel needles to plastic needles
- (4) Decrease the number of coils of wire around the iron nail

End of Booklet A



2018 PRIMARY 3 SEMESTRAL ASSESSMENT 2

Name : _____ ()

Date: 22 October 2018

Class : Primary 3 ()

Time: 8.00 a.m. – 9.30 a.m.

Parent's Signature : _____

Duration: 1 hour 30 minutes

SCIENCE

BOOKLET B

INSTRUCTIONS TO CANDIDATES

1. Write your name, class and register number.
2. Do not turn over this page until you are told to do so.
3. Follow all instructions carefully.
4. Answer all questions.
5. Write your answers in the booklet.

Booklet A	44
Booklet B	36
Total	80

Booklet B (36 marks)

For questions 23 to 34, write your answers clearly in this booklet.

The number of marks available is shown in brackets [] at the end of each question or part question.

(36 marks)

23. Alex put some snails, a dish of water and two different types of leaves, Leaf A and Leaf B, in a tank.

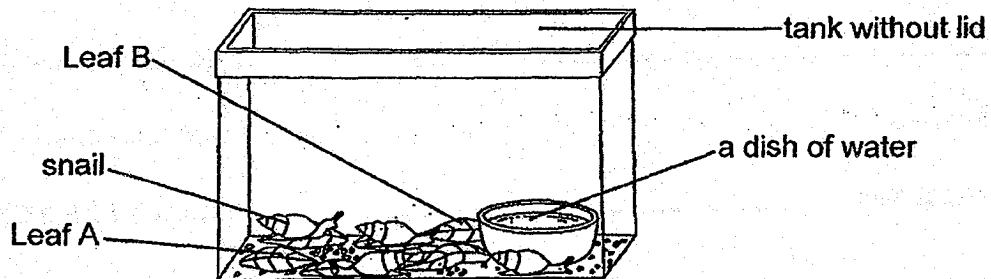

Over the next few weeks, he observed the number of snails, the amount of leaf A and the amount of Leaf B left in the tank. He recorded these in the table below.

Day	Number of snails	Amount of Leaf A (g)	Amount of Leaf B (g)
1	4	300	300
5	4	250	300
10	4	200	300
15	5	150	300
20	5	100	300

(a) Based on the table, what do the snails eat?

[1]

(b) The number of snails had increased over 20 days. Explain why.

[1]

(c) What can you conclude about the characteristics of living things from the table?

[1]

Score	3
-------	---

24. Study the diagrams below.

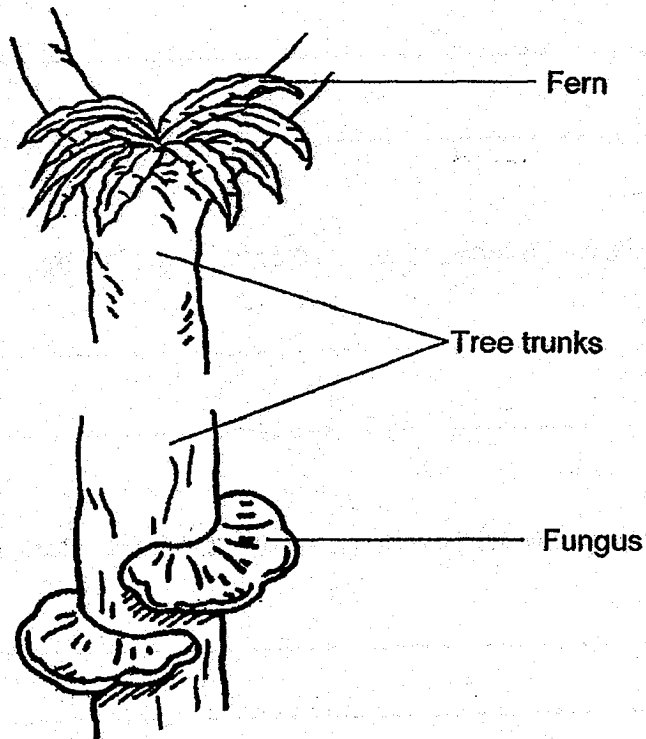



(a) Besides both living on a tree, state another similarity between the above fern and fungi. [1]

(b) State a difference between the fern and the fungi. [1]

Score	2
-------	---

(c) Two similar pieces of meat, A and B, were placed in different conditions as shown below.

		
Meat	A	B
Location of meat	On the table	In refrigerator

After 5 hours, which piece of meat, A or B, would have more bacteria?
Explain your answer. [1]

Score	1
-------	---

25. The drawing below shows a plant and its plant parts.

(a) Name the plant parts, E and F, in the boxes below.

[1]

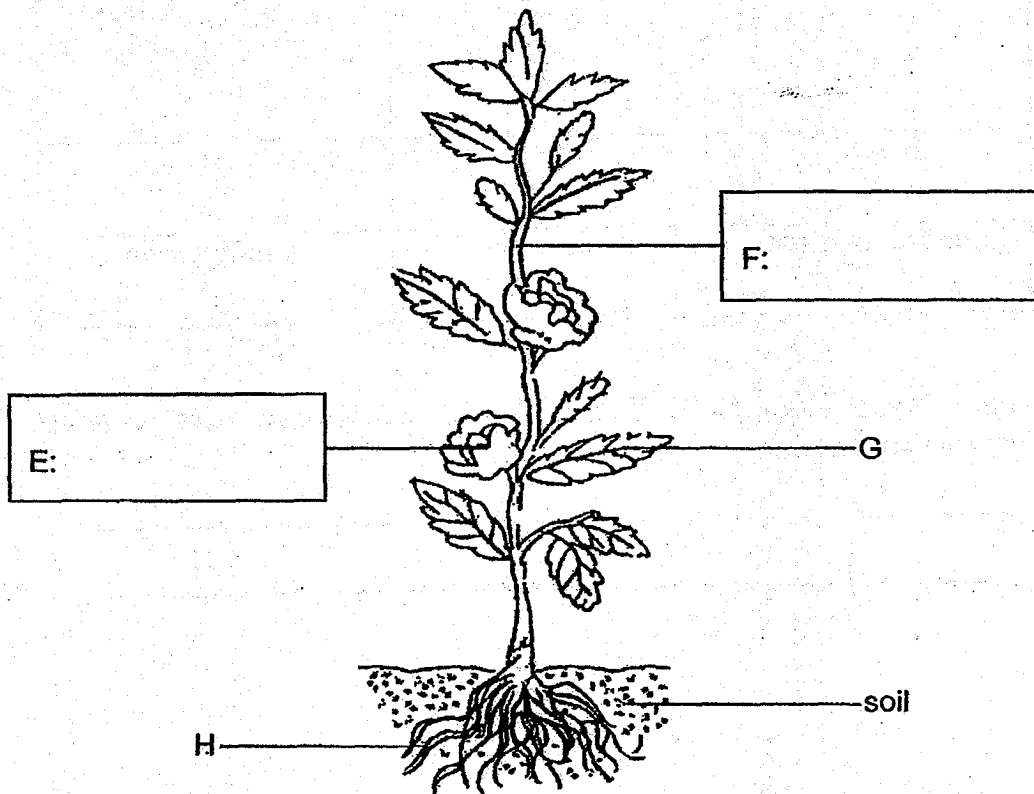

(b) State two functions of the part H.

[2]

Function 1: _____

Function 2: _____

Score	3
-------	---

26. The diagram below shows a plant with weak stem climbing up a pole.

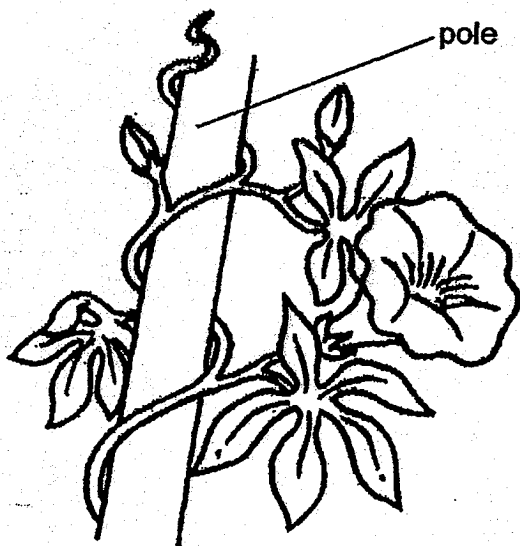

(a) What would happen to the plant if the pole is removed? [1]

(b) Explain how climbing up the pole helps the above plant to grow better. [2]

Score	3
-------	---

27. The diagrams below show two human organ systems.

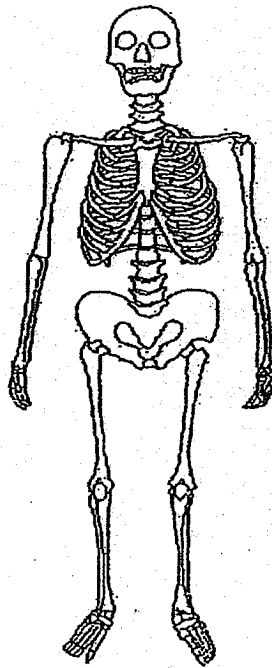

System X

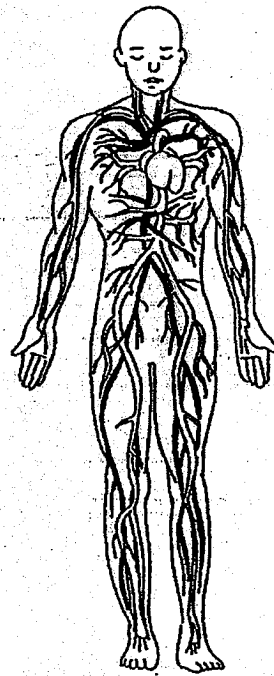

System Y

(a) Name System X and System Y, in the blanks below.

[2]

System X: _____

System Y: _____

(b) State one function of System X.

[1]

Score	3
-------	---

28. The human digestive system is shown below.

(a) Label the parts shown.

[2]

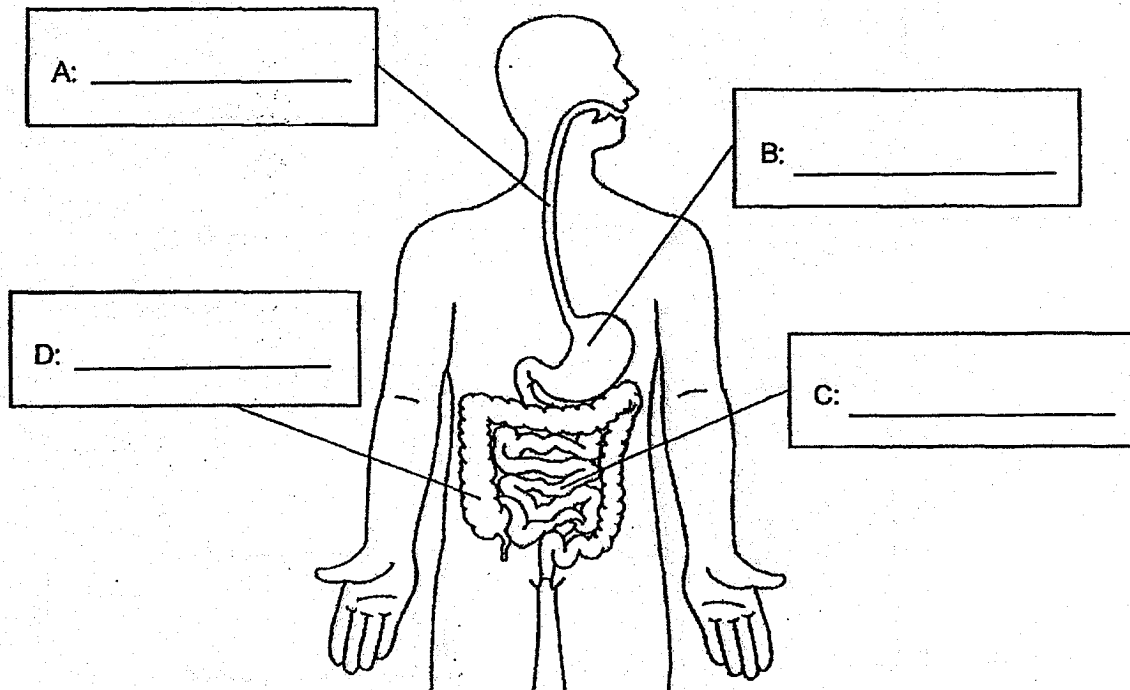

(b) Linda made a statement, "Digestion ends at D."

Linda's teacher said that her statement was incorrect. Explain why.

[1]

Score	3
-------	---

29. Mandy wanted to compare the flexibility of four materials of similar thickness, P, Q, R and S. She prepared the set-up below.

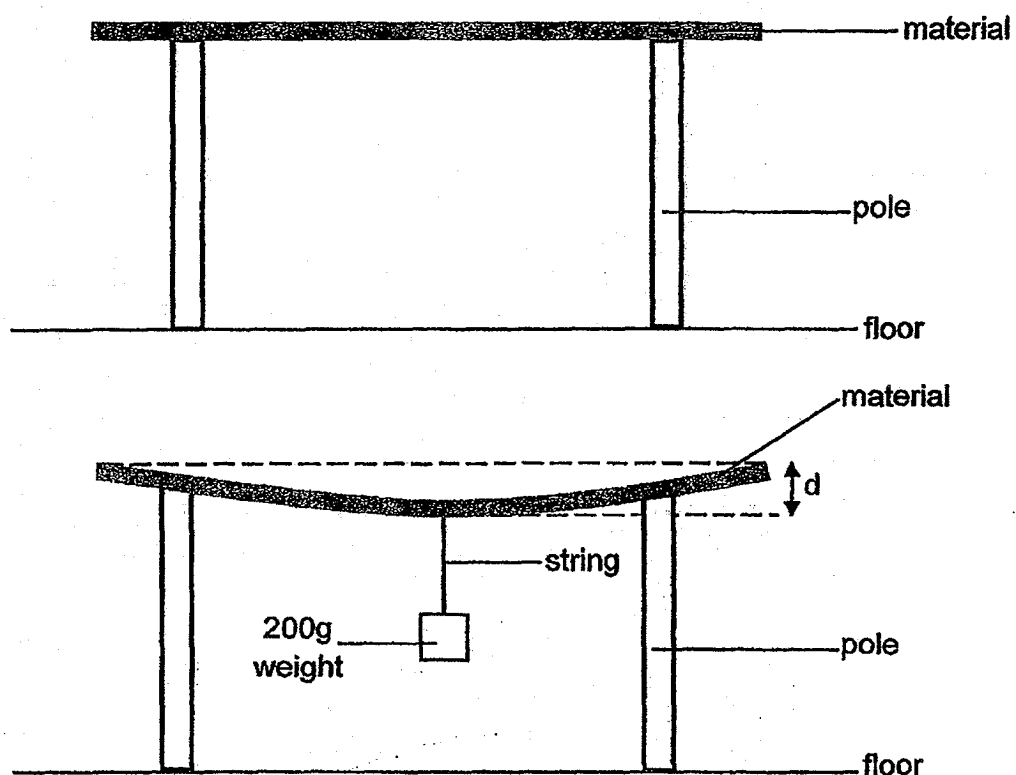

She hung a 200g weight on each sheet of material using a string of the same length and thickness and observed how much the material bent. She then measured the distance d shown above. She recorded the results in the table below.

Material	Distance d (cm)
P	0
Q	8
R	3
S	5

- (a) Arrange the materials, P, Q, R and S, from the most flexible to the least flexible. [1]

Most flexible \longrightarrow Least flexible

--	--	--	--

Score	1
-------	---

(b) The diagram below shows a ladder.

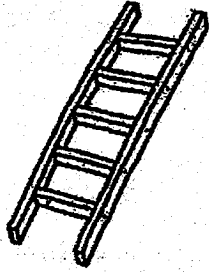

Which material, P, Q, R or S, is most suitable to make the ladder? Explain why. [1]

(c) Andy fell into the water from a boat. He cannot swim.

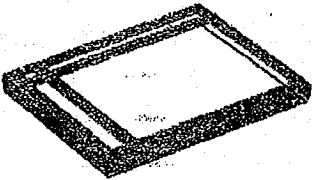
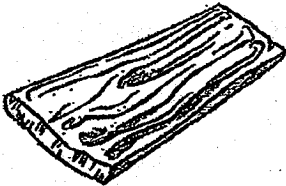

His younger brother threw him the following two objects.

ceramic tile	wooden plank
	

Assuming both objects are strong, which object should Andy hold on in the water to till help arrives? Explain your answer. [1]

Score	2
-------	---

30. Ken wants to pitch a tent for camping as shown below. The tent is to protect him from the wet weather when Ken sleeps in the night. The tent must be light enough for him to carry. It can also be folded to be kept in his bag.



- (a) Which property must material X have in order to protect Ken from wet weather? Explain your answer. [1]

- (b) Based on the above diagram, what property must material Y have? Explain your answer. [1]

- (c) What would Material X most likely be? Put a tick (✓) in the correct box below. [1]

Wood

Metal

Plastic

Ceramic

Score	3
-------	---

31. Ben carried out an experiment with a bar magnet and 3 different bars, W, X and Y. The ends of the bars are labelled as A and B. He brought the south pole of the bar magnet near the ends of the three bars.

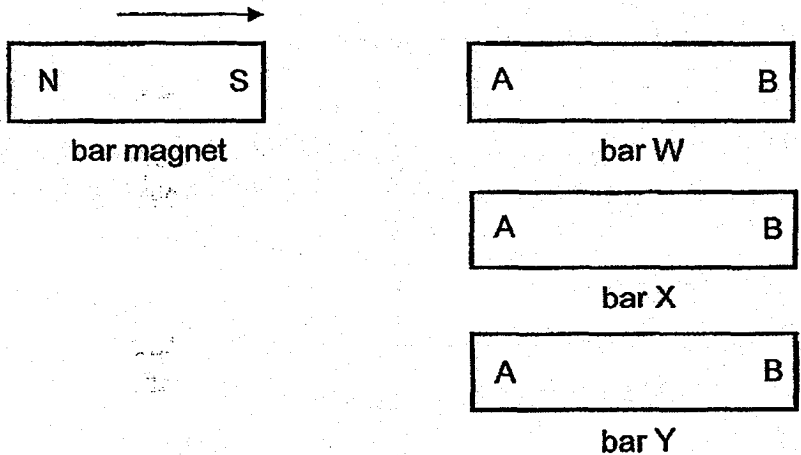

He recorded his observations in the table below.

Bar	Reaction to the south pole of the magnet	
	A	B
W	repel	attract
X	attract	attract
Y	no reaction	no reaction

(a) Based on the results above, can bar Y be made of plastic? Explain your answer. [2]

(b) Which bar, W, X or Y, is a magnet? Explain your answer. [1]

Score	3
-------	---

32. Jessica placed a piece of material A and B of the same thickness over the mouth of two similar empty containers. She then poured the same amount of water onto each material. The diagrams below show what she observed after 5 minutes.

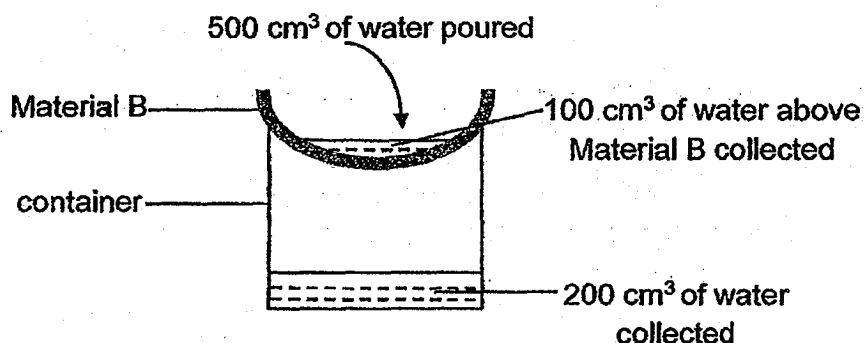
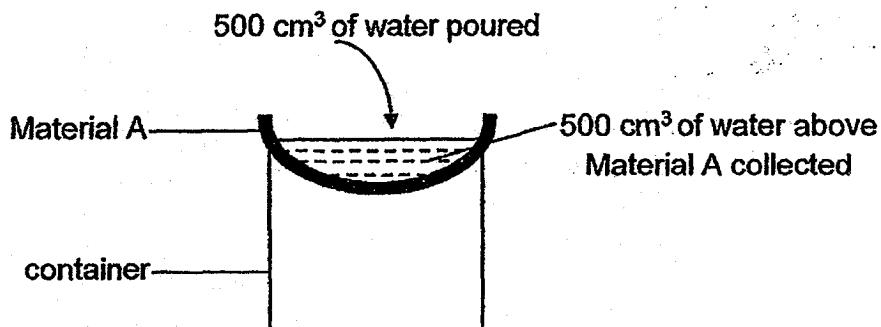

(a) What property of the material was Jessica trying to find out? [1]

(b) What can Jessica do to make the results of her experiment more reliable? [1]

Score	2
-------	---

(c) Uncle John works in a market with wet floor. He wears the following pair of boots to work.

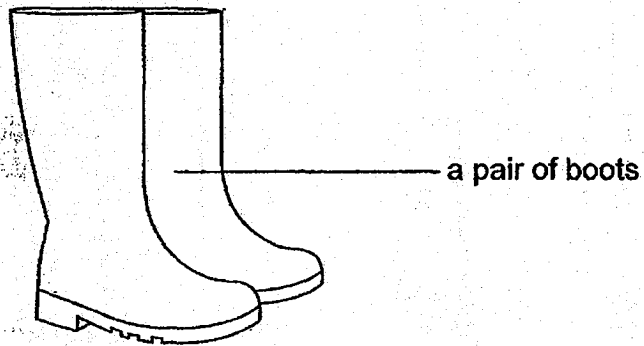

Based on the observations above, which material, A, B, C or D, is most suitable for making his boots? Explain your answer. [1]

Score	1
-------	---

33. Jasmine hung four magnets, P, Q, R, and S, above a tray of identical steel paper clips. Her observation is shown below.

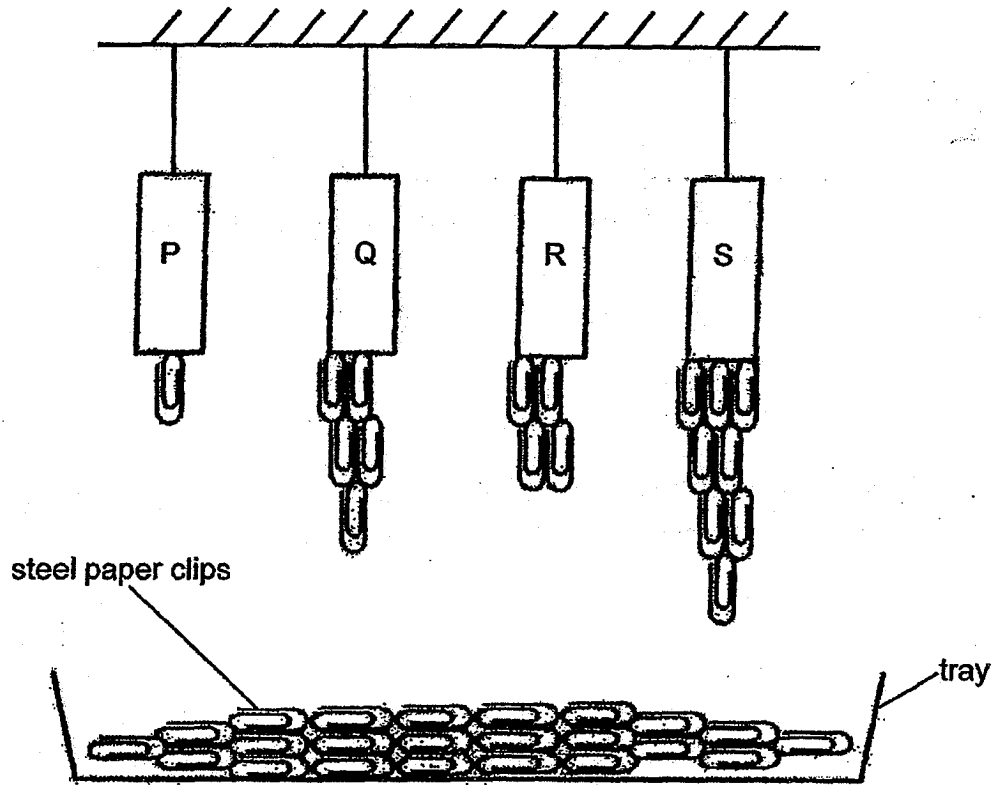

- (a) Based on her observation, which is the strongest magnet? Explain your answer. [1]

Score	1
-------	---

The diagram below shows a refrigerator with its door open.

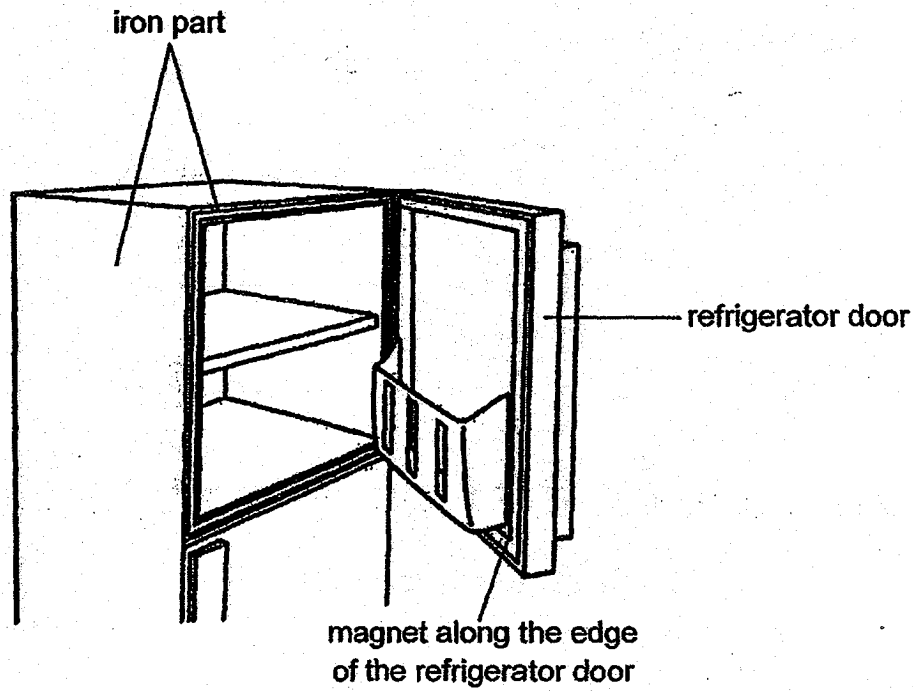

(b) Explain how the magnet along the edge of the refrigerator door keep the refrigerator door tightly shut. [2]

Score	2
-------	---

34. Joanna placed four identical ring magnets, A, B, C and D, through a wooden rod on a wooden base. She observed that these magnets were able to float at a distance away from each other as shown in the drawing below.

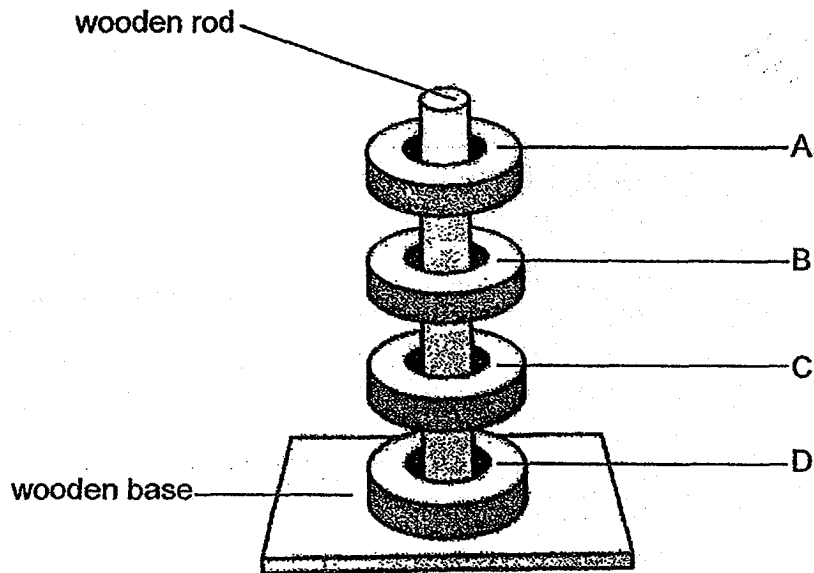

- (a) Explain why the magnets, A, B, C and D, were floating a distance away from each other. [2]

- (b) What can be done to make all the four magnets, A, B, C and D, attract each other? [1]

Score	3
-------	---

End of Paper

EXAM PAPER 2018 (P3)

SCHOOL : TAO NAN

SUBJECT : SCIENCE

TERM : SA2

Q1	Q2	Q3	Q4	Q5	Q6	Q7	Q8	Q9	Q10
2	4	3	1	3	4	1	1	3	1
Q11	Q12	Q13	Q14	Q15	Q16	Q17	Q18	Q19	Q20
2	1	4	3	1	4	4	4	2	1
Q21	Q22								
3	1								

Q23) a) snails eat leaves

- b) The mother snail is giving birth.**
- c) Living things need air, food and water to survive.**

Q24) a) Both reproduce by spores.

- b) Fern is a plant but Fungus is not a plant.**
- c) A. As A has more warmth for bacteria to grow faster.**

Q25) a) F : stem E : flowers

b) Function 1 : Part H holds the plant firmly to the ground.

Function 2 : Part H absorb water and mineral salt.

Q26) a) There will fall and die.

b) The plant can trap more sunlight to make more food.

Q27) a) System X : Skeletal system

System Y : Circulatory

b) System X gives our body shape.

Q28) a) A : Gullet B : Stomach C : small intestine D : large intestine

b) Digestion ends at C.

Q29) a) Q – S – R – P

b) P. Because P is the least flexible so the ladder will not bend when the person climbs on it.

c) Wooden plank as it can float while ceramic tile will sink.

Q30) a) Waterproof. If it is not the tent will be soaked with water.

b) Y must be strong so that it can hold the tent in place.

c) Plastic

Q31) a) Yes. Plastic is non-magnetic and cannot be attracted by the magnet just like Y.

b) W, because it can repel and attract another magnet.

Q32) a) Water proof or not

b) Repeat the experiment a few minutes.

c) Material A. As his boots must be waterproof so that water cannot enter his boots.

Q33) a) S. It can hold the most steel paper clips.

b) Iron is magnetic so the magnet attracts the iron part.

Q34) a) They are repelling each other. The like poles of the magnet are facing each other so the magnet repel.

b) Flip A and C