

Name : _____ ()

Class : Primary _____

CHIJ ST NICHOLAS GIRLS' SCHOOL

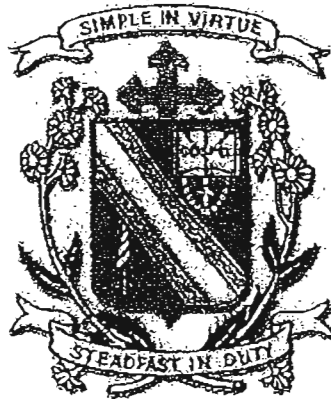

德 純 义 堅

Primary 4

First Semestral Assessment – 2007

SCIENCE

BOOKLET A

9th May 2007

Total Time for Booklets A and B: 1 hour 45 minutes

**30 questions
60 marks**

**Do not open this booklet until you are told to do so.
Follow all instructions carefully.
Answer all questions.**

Section A: (30 x 2 marks)

For each question from 1 to 30, four options are given. One of them is the correct answer. Make your choice (1, 2, 3 or 4). Shade the correct oval (1, 2, 3 or 4) on the Optical Answer Sheet.

1. Which of the following properties describe a matter?

- A: It has mass.
- B: It has volume.
- C: It can be seen.
- D: It can be touched.

- (1) A and B only
- (2) A and C only
- (3) B and D only
- (4) C and D only

2. The table below describes the properties of Substance X.

| | Has a definite shape? | Has a definite volume? | Can be compressed? |
|--------------------|-----------------------|------------------------|--------------------|
| Substance X | No | No | Yes |

What can Substance X be?

- (1) Honey
- (2) Cotton
- (3) Nitrogen
- (4) Plasticine

3. Which one of the following objects can be attracted by a magnet?

- A: Steel bar
- B: Nickel ring
- C: Gold chain
- D: Aluminium can

- (1) A and B only
- (2) A and C only
- (3) B and D only
- (4) C and D only

4. The diagram below shows a number of magnets attracted to each other.

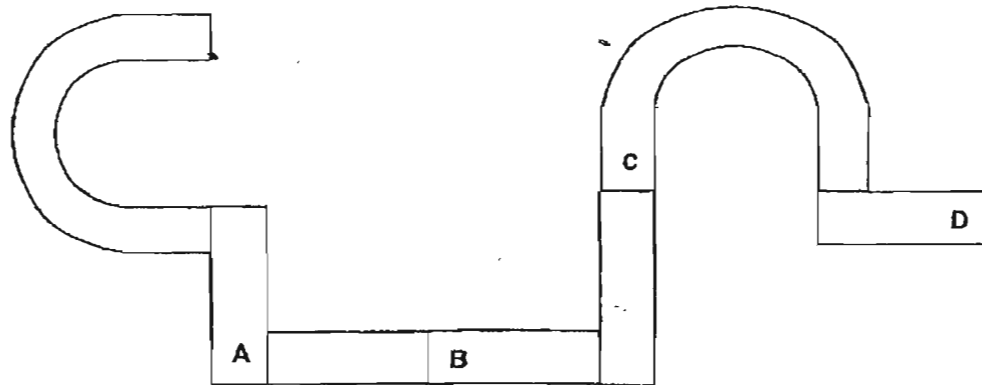

What could be the poles of A, B, C and D?

| | A | B | C | D |
|-----|----------|----------|----------|----------|
| (1) | North | South | North | South |
| (2) | North | South | South | North |
| (3) | South | North | South | North |
| (4) | South | South | North | North |

5. When Magnet A was brought near Magnet B, Magnet B moved away from Magnet A as shown in the diagram below.

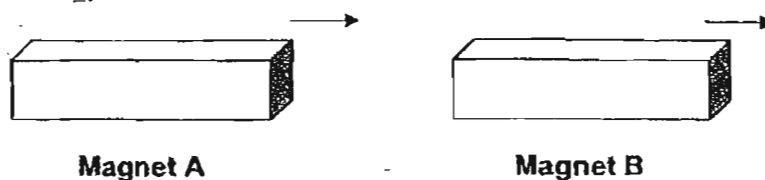

What can we conclude about Magnet A and B?

- (1) Magnet A has a stronger magnetism than Magnet B.
- (2) Magnet B has a stronger magnetism than Magnet A.
- (3) The like poles of Magnet A and Magnet B are facing each other.
- (4) The unlike poles of Magnet A and Magnet B are facing each other.

6. Study the flowchart below.

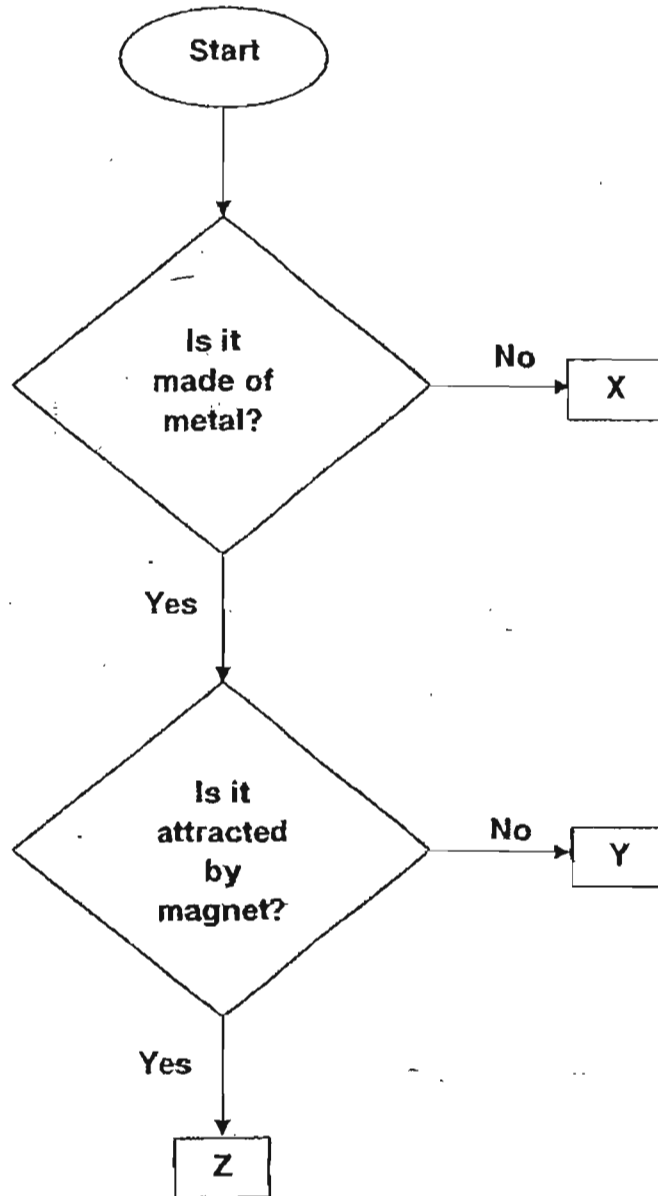

Which one of the following statements is correct?

- (1) X is a magnetic metal.
- (2) Z is a magnetic metal.
- (3) Both Y and Z are magnetic metals.
- (4) Both X and Y are non-magnetic metals.

7. An iron nail becomes a magnet when it is placed in a coil of wire joined to batteries.
Jasmine sets up two arrangements as shown below. For each arrangement, she counted the number of paper clips it can attract.

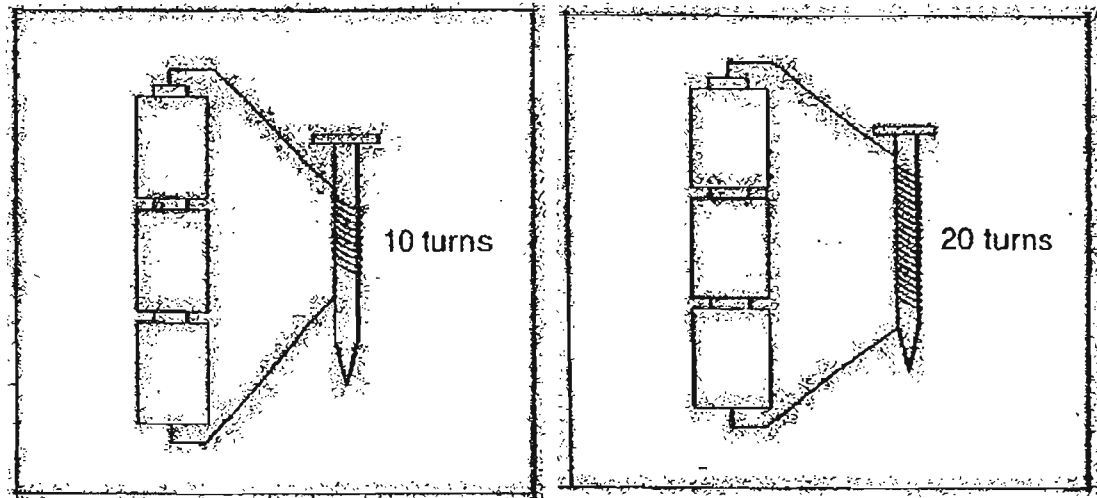

Jasmine is trying to find out whether _____.

- (1) the number of batteries affects the strength of a magnet
 - (2) the type of battery used affects the strength of a magnet
 - (3) the type of iron nail used affects the strength of a magnet
 - (4) the number of turns of coils affects the strength of a magnet
8. Three children made the following statements about water.

Ali : Dew is water in the gaseous state.
Betty : Water exists in three different states.
Corina : Steam is produced when water boils.

Whose statement(s) is/are correct?

- (1) Ali only
- (2) Betty only
- (3) Ali and Betty only
- (4) Betty and Corina only

9. Sarah filled a container with water as shown in Figure 1 below. When she put an egg into the container, some water overflowed into beaker A as shown in Figure 2.

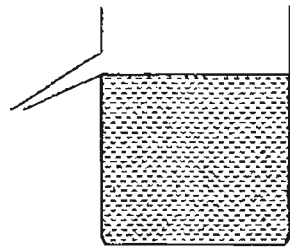

Figure 1

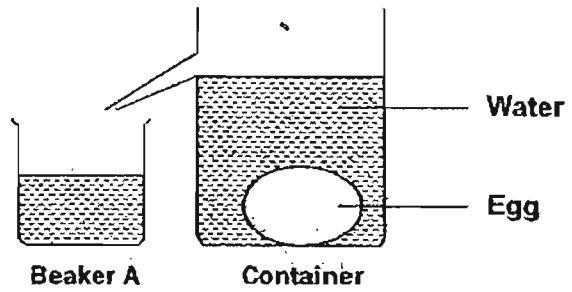

Figure 2

The experiment shows that the egg _____.

- (1) has mass
- (2) has a definite volume
- (3) has no definite shape
- (4) cannot be compressed

(2)

10. The cup in the diagram below contains 100cm^3 of air.

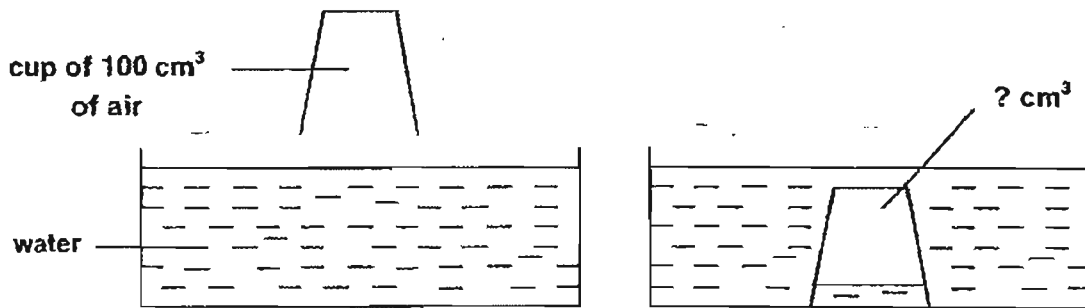

When the cup is pushed down into the water, what is the likely volume of air in the cup?

- (1) 0 cm^3
- (2) 90 cm^3
- (3) 100 cm^3
- (4) 110 cm^3

11. Study the diagram below.

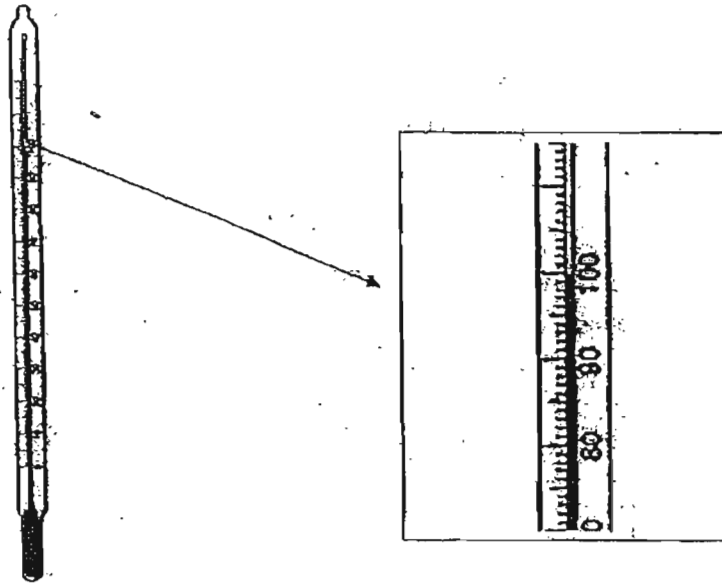

The thermometer above shows the temperature when water _____.

- (1) boils
 - (2) melts
 - (3) freezes
 - (4) condenses
12. John took out a glass of cold orange juice from the refrigerator and placed it on the table in a room. After 5 minutes, he observed that tiny water droplets were formed on the outer surface of the glass as shown in the diagram below.



Where does the water droplets come from?

- (1) Refrigerator
- (2) Orange juice
- (3) Surrounding air
- (4) Outer surface of the glass

13. Susan wanted to find out the effects of temperature on the rate of evaporation. She poured an equal amount of water into four containers as shown below. She placed each of them in four different places of varying temperatures. However, Susan's teacher said that it was not a fair test.

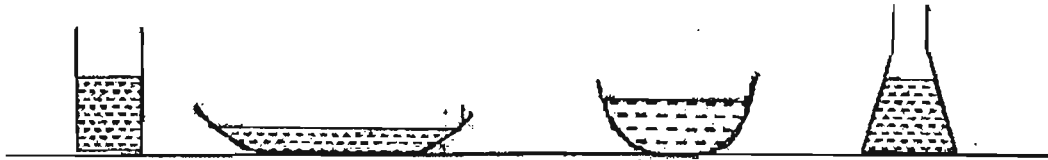

What should Susan do to her set-up to ensure a fair test?

- (1) Use identical containers.
 - (2) Place all containers in the same location.
 - (3) Use different amount of water in each container.
 - (4) Use different types of liquid for all the containers.
14. Study the diagram below carefully. The arrows A, B, C and D are processes which represent the change in the states of water.

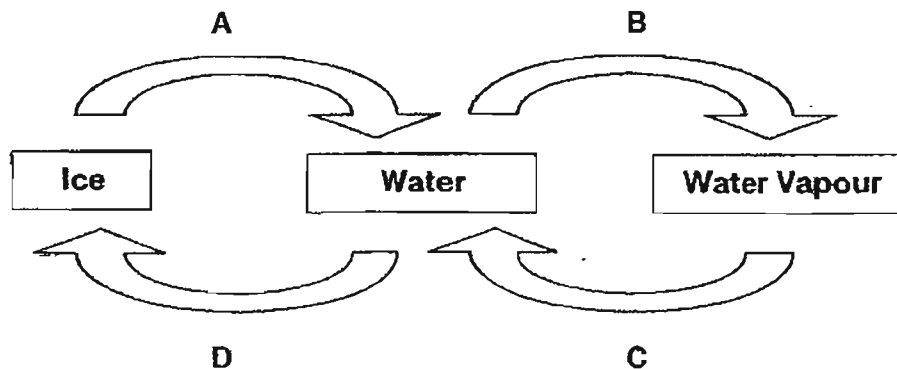

Which one of the following matches the processes in arrows A, B, C and D?

| | A | B | C | D |
|-----|--------------|--------------|--------------|--------------|
| (1) | Melting | Evaporation | Condensation | Freezing |
| (2) | Freezing | Condensation | Evaporation | Melting |
| (3) | Evaporation | Freezing | Melting | Condensation |
| (4) | Condensation | Melting | Freezing | Evaporation |

15. The table below shows the melting points and boiling points of four different substances P, Q, R and S.

| Substance | Melting point (°C) | Boiling point (°C) |
|-----------|--------------------|--------------------|
| P | 5 | 110 |
| Q | 36 | 89 |
| R | 55 | 90 |
| S | 60 | 99 |

Which one of the substances is a liquid at 25°C?

- (1) P
 - (2) Q
 - (3) R
 - (4) S
16. The table below shows statements made by 4 pupils about the factors affecting the rate of evaporation of a liquid.

| | |
|--------|--|
| Alice | The lower the temperature of the surroundings, the higher the rate of evaporation of the liquid. |
| Ben | The stronger the wind, the higher the rate of evaporation of the liquid. |
| Chloe | The greater the exposed surface area of the liquid, the higher the rate of evaporation. |
| Dennis | The lower the humidity, the lower the rate of evaporation of the liquid. |

Whose statements are correct?

- (1) Alice and Ben only
- (2) Ben and Chloe only
- (3) Alice and Dennis only
- (4) Chloe and Dennis only

17. Eunice poured some boiling water into a beaker and heated it over a flame as shown in the diagram below.

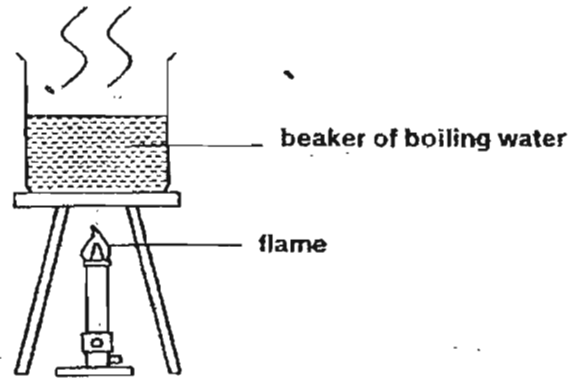

After 10 minutes, Eunice removed the beaker of boiling water and put it in the freezer for two hours.

Which one of the following graphs shows the changes in the temperature of the water throughout the experiment?

(1)

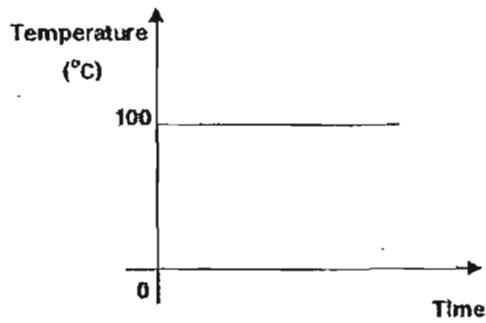

(2)

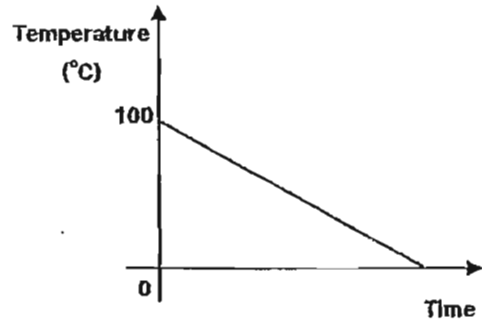

(3)

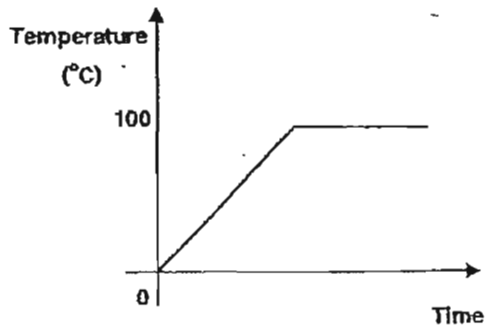

(4)

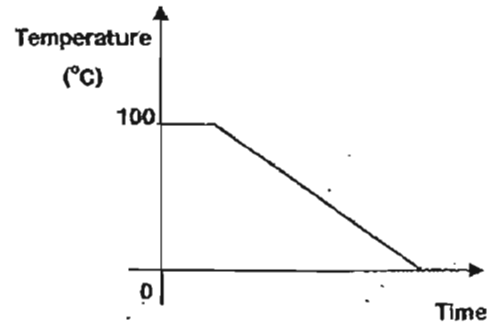

18. A test tube of red coloured water at room temperature is put into a beaker of crushed ice as seen in the diagram below.

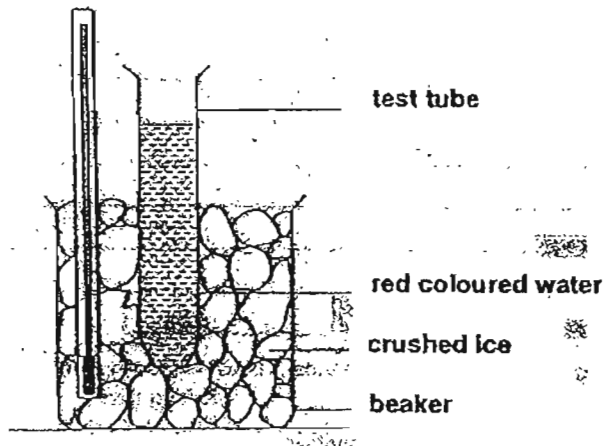

The set-up is left in a room for 5 minutes. Which one of the following observations is **incorrect**?

- (1) The ice in the beaker is melting.
 - (2) The red coloured water has turned into ice.
 - (3) Water droplets appear at the side of the beaker.
 - (4) The temperature of the ice cubes remains at 0°C .
19. Water is polluted when _____.
- (1) rain water flow into the drain
 - (2) there are fishes in the reservoir
 - (3) water from the sink flows straight into the sewer
 - (4) wastes from the chemical factories flows straight into the sea

20. The diagram below shows the water cycle.

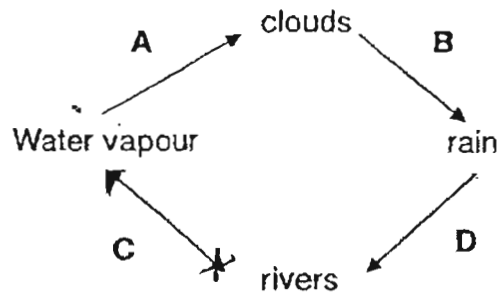

Which stage(s) of the water cycle does/do not involve a change in state?

- (1) D only
 - (2) A and C only
 - (3) B and D only
 - (4) A, B and C only
21. Which one of the following activities **does not** conserve water?
- (1) Repair any water leakage immediately.
 - (2) Rinse the mouth under running tap water.
 - (3) Replace the hose with a pail when washing cars.
 - (4) Recycle the water used for washing rice to water the plants.

22. The diagram below shows a glass container. It has a rubber stopper with glass tube and a filter funnel.

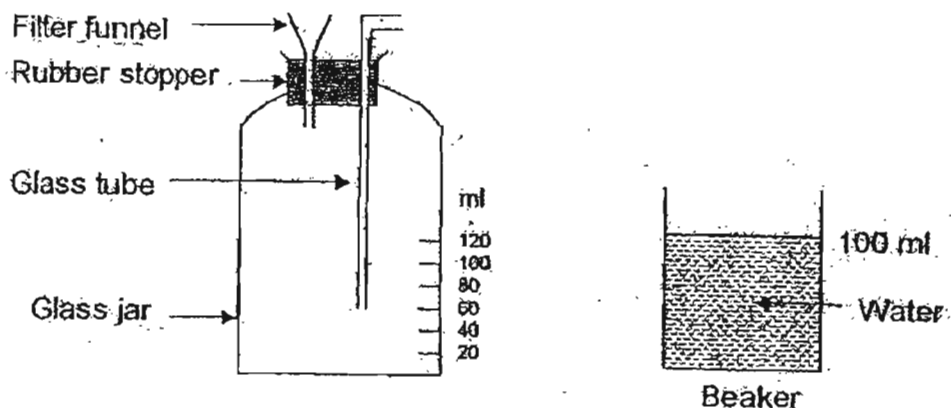

John found that he could not pour all the water in the beaker into the glass jar through the funnel with a narrow tube.

About how much water in the beaker could be poured into the glass jar?

- (1) 20 ml
 - (2) 40 ml
 - (3) 60 ml
 - (4) 70 ml
23. Three identical burning candles, A, B and C are placed in gas jars of different sizes as shown in the diagram below. It is observed that the flames of the three candles extinguished at different times.

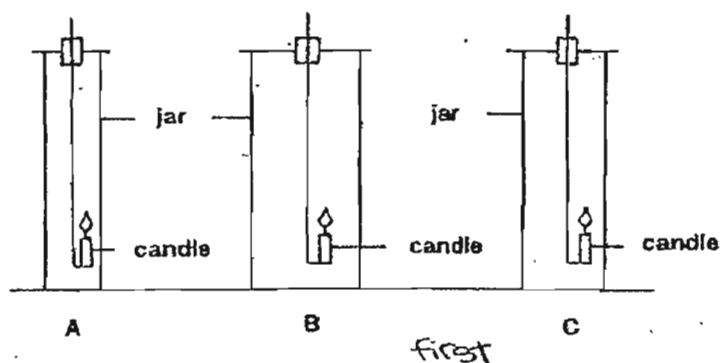

In which order do the candles extinguish?

- (1) A, B, C
- (2) A, C, B
- (3) B, A, C
- (4) B, C, A

24. Lily carried out an experiment with two balloons as shown in the diagram below.

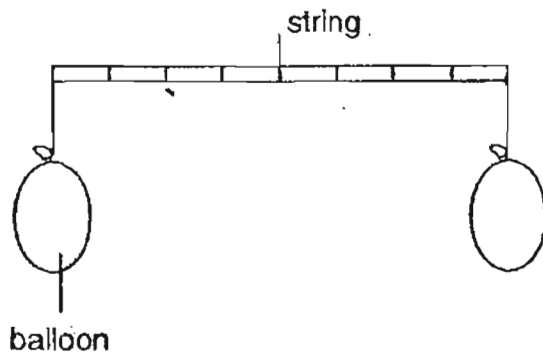

Start of experiment

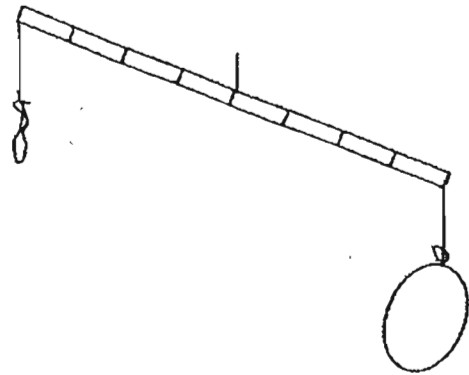

End of experiment

The aim of her experiment is to show that _____.

- (1) air has mass
 - (2) air can be compressed
 - (3) rubber has no definite shape
 - (4) rubber can be used to make balloons
25. Which of the following objects make use of magnets in order to function?

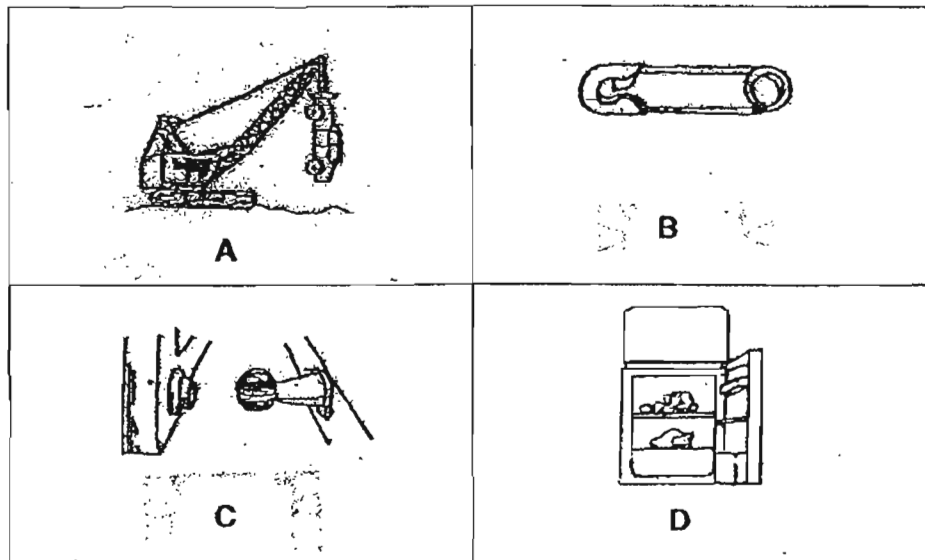

- (1) A, B and C only
- (2) A, B and D only
- (3) A, C and D only
- (4) B, C and D only

26. Ravi wanted to buy the strongest magnet from a shop. She tested 4 magnets with paper clips and recorded the furthest distance from which each of the magnets can attract the paper clip in the diagram below.

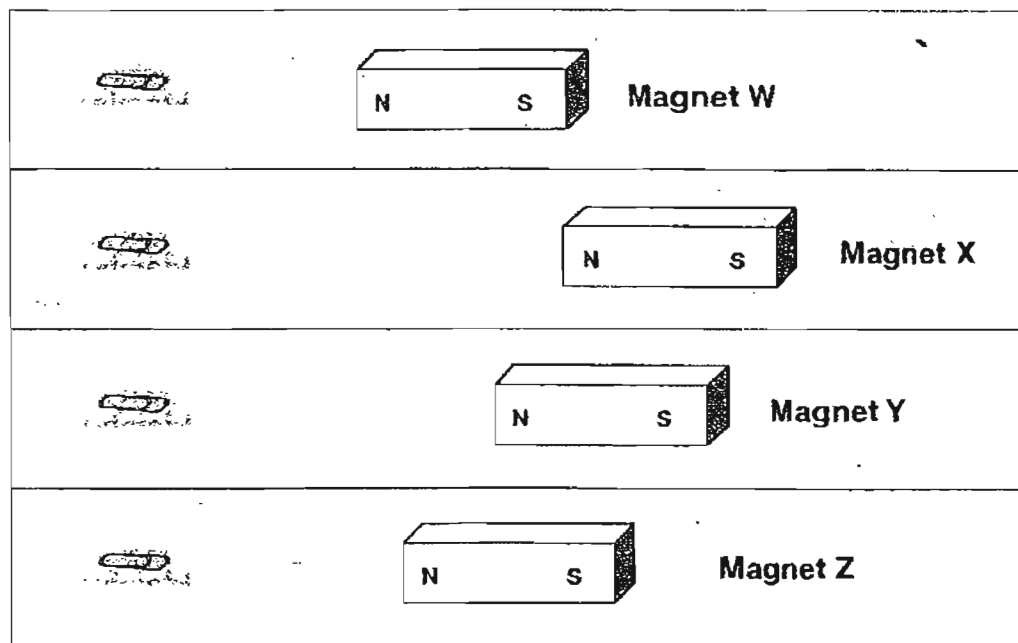

Which one of the magnets is the strongest?

- (1) Magnet W
 - (2) Magnet X
 - (3) Magnet Y
 - (4) Magnet Z
27. Which of the following statements about the uses of oxygen are **incorrect**?
- A: It is used for burning.
 - B: It is used for welding.
 - C: It is used to make fertilisers.
 - D: It is used to make fizzy drinks.
- (1) A and B only
 - (2) A and C only
 - (3) B and D only
 - (4) C and D only

28. The table below shows some animals being classified according to the way they breathe.

| A | B | C |
|---------|------------|----------|
| Whale | Frog | Seahorse |
| Dolphin | Salamander | Guppy |

Which one of the following correctly identifies the breathing methods of A, B and C?

| | A | B | C |
|-----|------------|------------|------------|
| (1) | Gills | Lungs | Moist skin |
| (2) | Lungs | Moist skin | Gills |
| (3) | Blow hole | Gills | Lungs |
| (4) | Moist skin | Lungs | Blow hole |

29. The bar charts below shows the proportion of air.



Each composition of air is represented by the different shading below.



X



Y



Z

Which one of the following best represents X, Y and Z?

| | X | Y | Z |
|-----|----------------|----------|--------------|
| (1) | Water vapour | Nitrogen | Oxygen |
| (2) | Carbon dioxide | Oxygen | Nitrogen |
| (3) | Water vapour | Oxygen | Nitrogen |
| (4) | Carbon Dioxide | Nitrogen | Water vapour |

30. Jane bought some fishes and put them in a container of water as shown below.

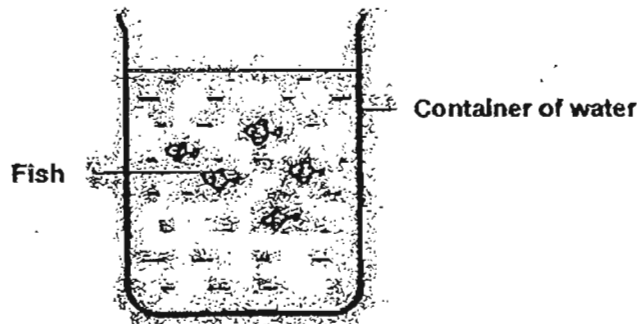

Jane was worried that the fishes might not have enough air in the water. What should she do to ensure sufficient supply of air in the water?

- (1) Add soil into the water
- (2) Add more fishes into the water
- (3) Add aquatic plants into the water
- (4) Add more food to feed the fishes

*******End of Section A*******

Name : _____ ()

Class : Primary _____

CHIJ ST NICHOLAS GIRLS' SCHOOL



德 結 义 堅

Primary 4

First Semestral Assessment – 2007

SCIENCE

BOOKLET B

9th May 2007.

Total Time for Booklets A and B: 1 hour 45 minutes

**16 questions
40 marks**

| | |
|-----------|-----|
| Booklet A | 60 |
| Booklet B | 40 |
| Total | 100 |

**Do not open this booklet until you are told to do so.
Follow all instructions carefully.
Answer all questions.**

Parent's Signature/Date

Section B: (40 marks)

Answer all the questions in the spaces provided.

31. Four objects, P, Q, R and S are put close to each other to test if they are magnets. The results are shown below.

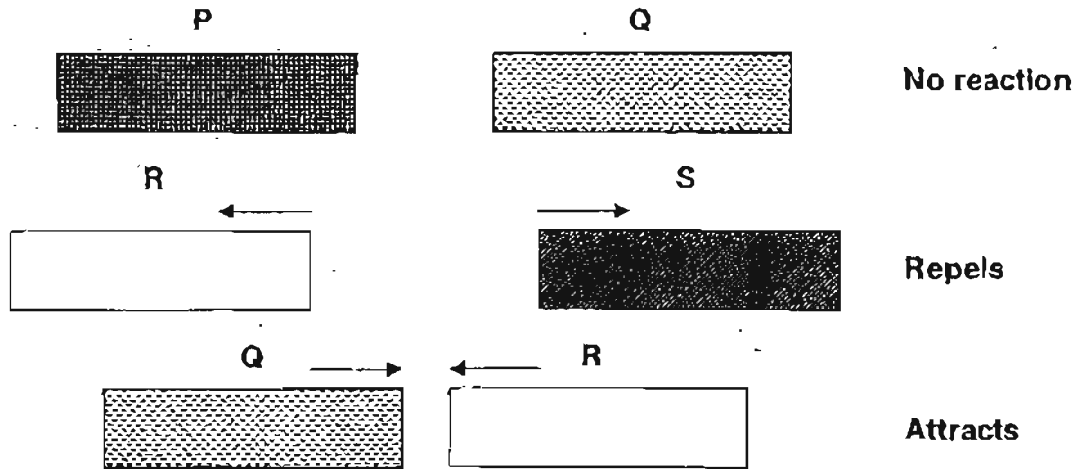

- (a) Which of the objects P, Q, R and S are definitely magnets? (1m)

- (b) Which object is a non-magnetic material? (1m)



32. Henry has a sponge cube and a cylinder as shown in the diagram below.

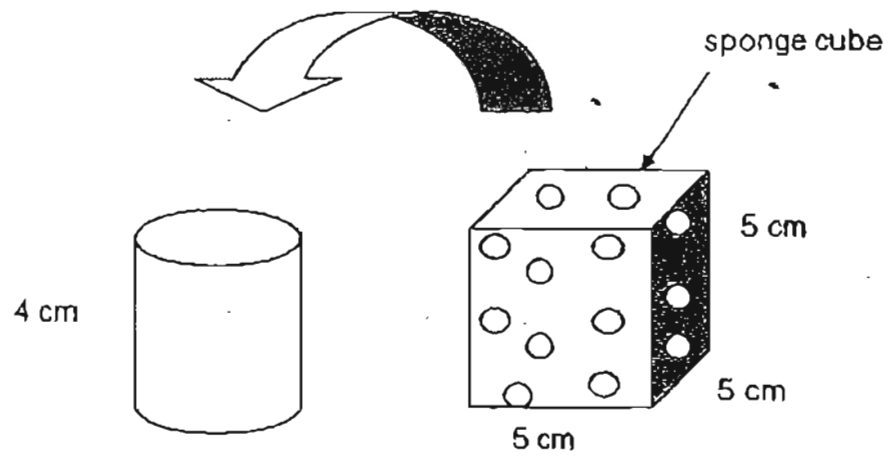

- (a) Henry finds out that he can squeeze the sponge into the cylinder. Why is this so? (1m)

- (b) What will Henry observe if he repeats the experiment with a solid cube of the same volume? Explain your answer clearly. (1m)



33. A plastic cup is filled to the brim with hot tea as shown in the diagram below.

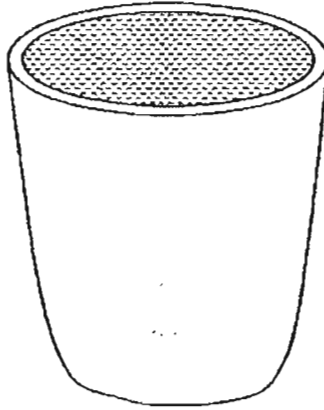

Plastic cup of hot tea

- (a) When the plastic cup is placed in a room at room temperature, the hot tea has cooled down. What does this observation show? (1m)

- (b) What will happen to the plastic cup if it is placed in the freezer overnight? (1m)

- (c) Explain your answer in (b). (1m)



34. **A** cannot be compressed. However, when it is heated, it will change its state to **B**. **B** takes up the shape of the container. Further heating will cause **B** to change its state to **C** and **C** can be compressed.

(a) What states do **A**, **B** and **C** represent? (1½m)

(i) **A** : _____

(ii) **B** : _____

(iii) **C** : _____

(b) What could be done in order to change the state of **B** back to **A**? Explain your answer.

(1m)

35. Study the diagram below.

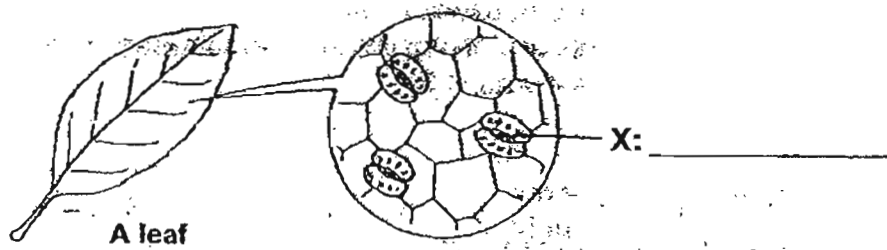

(a) Name the part on the leaf as indicated on the diagram. (1m)

(b) What will happen to the leaf if "X" is missing? (1m)



36. The diagram below shows the water cycle.

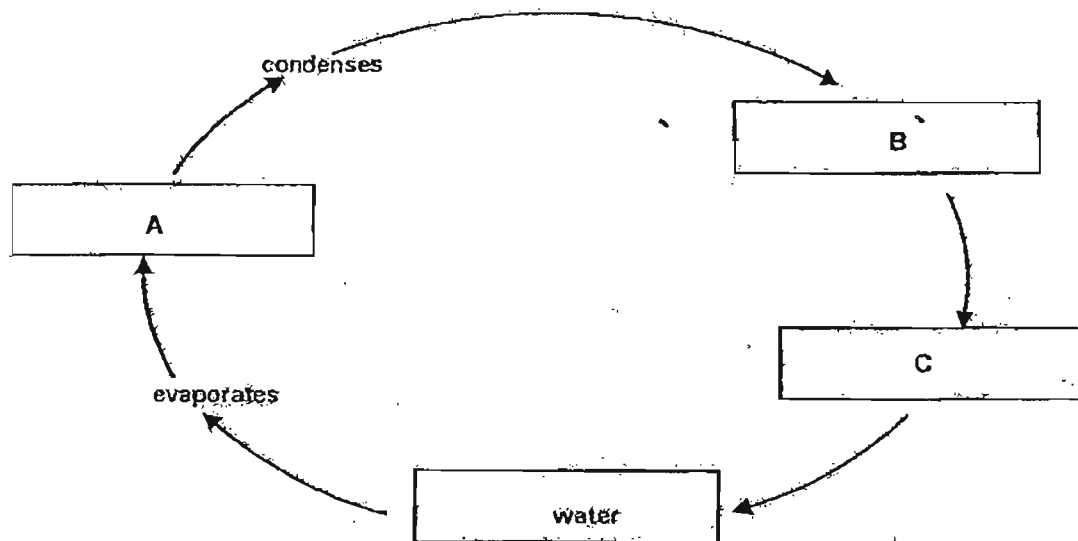

(a) What does each of the letters A, B and C represent? (1½ m)

(i) A : _____

(ii) B : _____

(iii) C : _____

(b) List one difference between the properties of A and C. (1m)

(c) Why is water cycle ⁺importance to all living things? (1m)

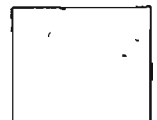

37. Kelly conducted an experiment as shown in the diagram below.

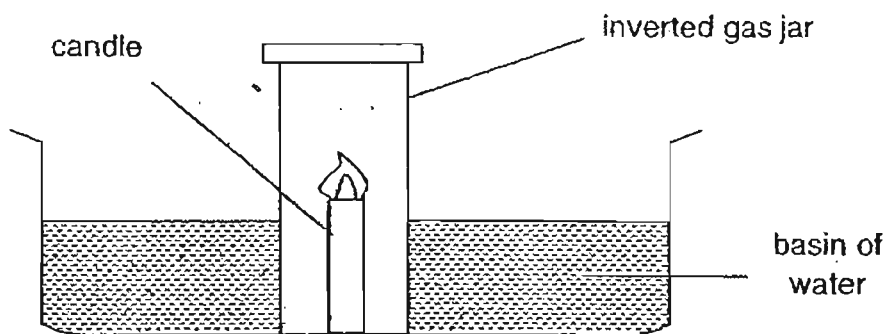

After a few minutes, Kelly observed that the flame went off after burning for a while.

- (a) What is one **OTHER** observation Kelly made from the above experiment? (1m)

- (b) Explain your answer in (a). (1m)

38. Mr Lee wanted to show his students the changes of state of water by setting up an experiment as shown below.

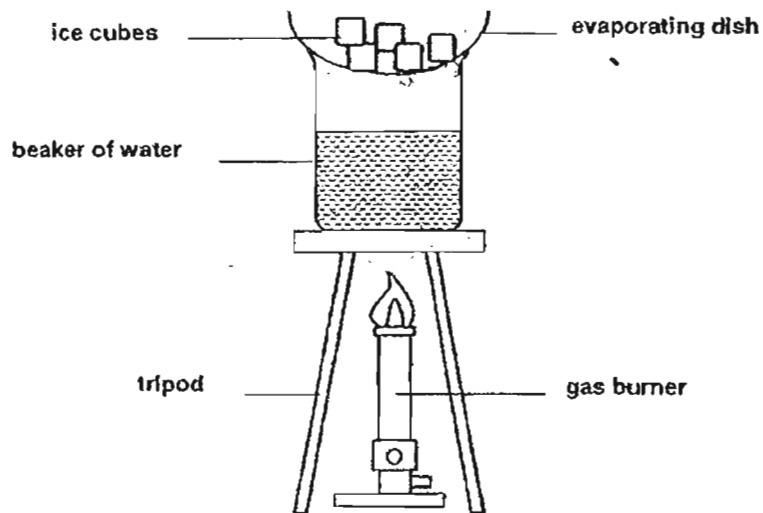

The steps taken are as follow:

| | |
|---------------|---|
| Step 1 | Heat the beaker of water until water boils. |
| Step 2 | Cover the beaker with evaporating dish. |
| Step 3 | Observe the bottom of the evaporating dish. |

- (a) Draw on the diagram above to show where the water droplets will be formed. (1m)
- (b) Explain clearly how the water droplets are formed. (2m)
-



39. Look at the picture of a fish below.

(a) Draw an arrow to indicate the gill cover on the picture below.

(1m)

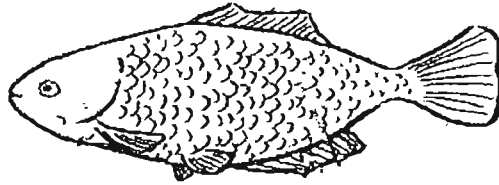

(b) State the function of the gill cover.

(1m)

(c) How are the gills useful to the fish?

(1m)

40. John was given a pot of soil and a tank of water to carry out an experiment to show that there is air in the soil.

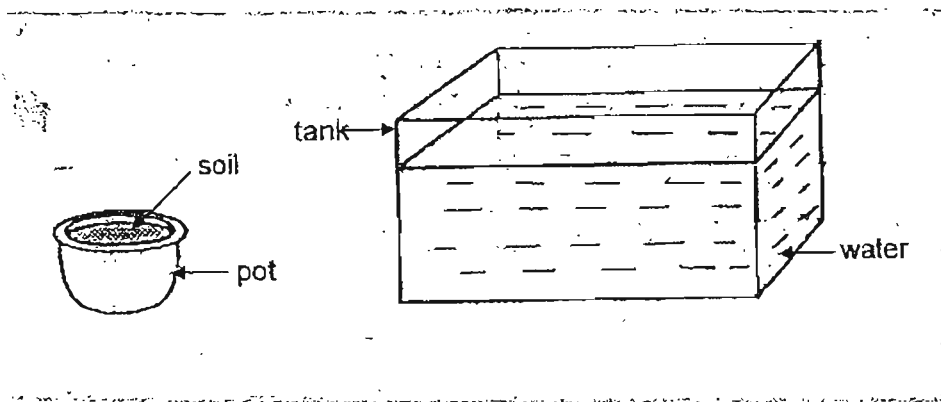

(a) What must he do to show that there is air in the soil?

(1m)

(b) What observation would tell him that there is air in the soil?

(1m)

41. Susan placed 10 water plants into four containers respectively. Each container had water from four different rivers. After many days, she counted the number of water plants left in the container and recorded her observations in the table below.

| Water taken from river | Number of water plants | | | |
|------------------------|------------------------|--------|--------|--------|
| | Day 5 | Day 10 | Day 15 | Day 20 |
| A | 10 | 8 | 6 | 3 |
| B | 10 | 10 | 10 | 10 |
| C | 10 | 12 | 14 | 16 |
| D | 10 | 10 | 13 | 15 |

- (a) From the table ^{above} ~~below~~, which river source is likely to be polluted? (1m)

- (b) What is the possible cause for the pollution? (1m)



42. Equal volume of water at 100°C is poured into two different containers P and S as shown in the diagram below.

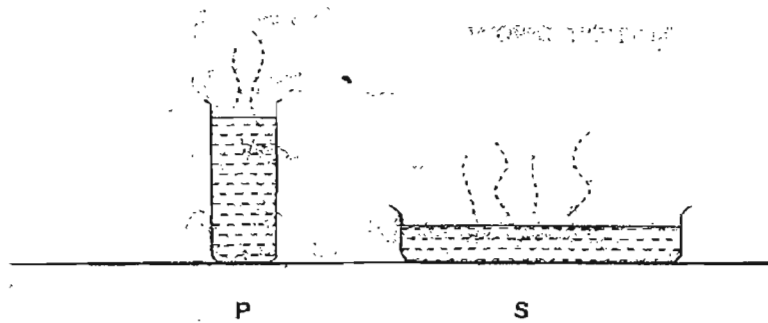

After a few hours, both containers P and S have the same amount of water left. Give two possible reasons for the above observation.

(2m)

43. The diagrams below show two different processes taking place.



Diagram A

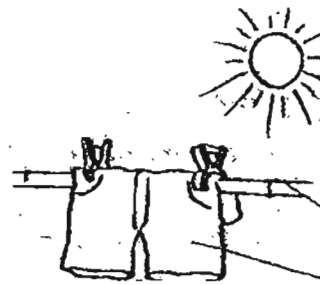

Diagram B

wet clothes

- (a) List one similarity between the two processes in Diagrams A and B. (1m)

- (b) List one difference between the two processes in Diagrams A and B. (1m)

44. An experiment was conducted using two sheets, X and Y, which are made of different materials.

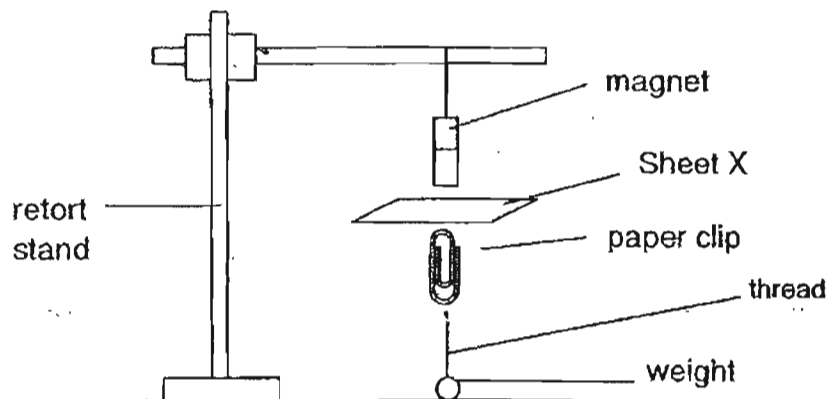

When Sheet X was held below the suspended magnet, the paper clip was lifted. When the experiment was repeated using Sheet Y, the paper clip was not lifted.

Andrew was told that one sheet was made of iron while the other was made of plastic.

- (a) Based on the experiment, identify the type of materials Sheet X and Sheet Y are made of. (2m)

(i) Sheet X: _____

(ii) Sheet Y: _____

- (b) Explain clearly your answer above. (1m)

45. Air was pumped into a completely deflated football. The graph below shows the volume of air in the basketball as air is pumped into it. No air was leaked during the pumping process.

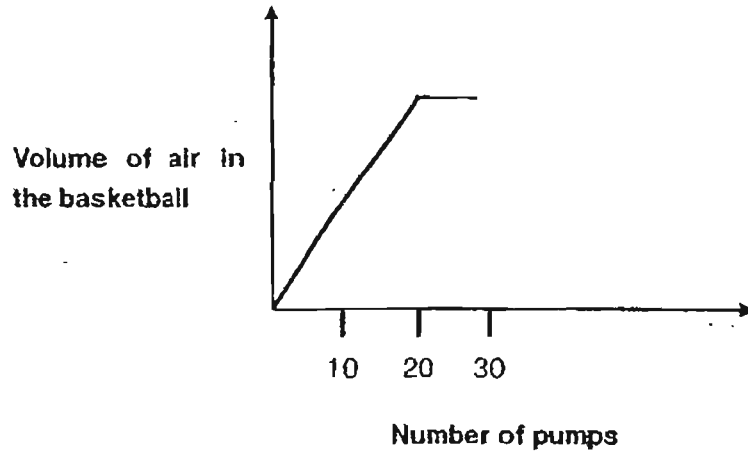

- (a) What can Rani conclude about the volume of air in the basketball after 20 pumps? (1m)
-

- (b) Rani noticed that she could not pump in any more air into the basketball after 30 pumps. Why? (1m)
-

46. The diagram below shows a fire extinguisher.

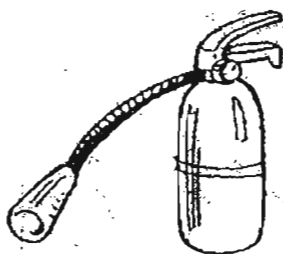

(a) What is the gas found in the fire extinguisher? (1m)

(b) State two other uses of the gas in (a). (2m)

(c) Name another gas which can be used to put out fire. (1m)

-- End of Paper --

Have you checked your paper?





ANSWER SHEET

CHIJ PRIMARY SCHOOL - PRIMARY 4 SCIENCE 2007
SEMESTRAL ASSESSMENT (1)

1. 1
 2. 3
 3. 1
 4. 2
 5. 3
 6. 2
 7. 4
 8. 4
 9. 2
 10. 1
 11. 1
 12. 1
 13. 1
 14. 1
 15. 1
 16. 2
 17. 2
 18. 1
 19. 4
 20. 3
 21. 2
 22. 1
 23. 2
 24. 1
 25. 3
 26. 2
 27. 4
 28. 2
 29. 1
 30. 3
- 31) a) Objects R and S.
b) Object P.
- 32) a) The air in the sponge can be compressed.
b) The solid cube could not fit in the cylinder as it could not be compressed.
- 33) a) The hot tea loses heat to the surroundings.
b) The plastic cup will crack.
c) The tea will freeze and the volume will increase.
- 34) a) i) solid, ii) liquid, iii) gas
b) Put B in the freezer. When the liquid state loses heat, it would change into a solid state, which is A.
- 35) a) X: stomata
b) Plants can take in carbon dioxide to make food.
- 36) a) i) water vapour
ii) clouds
iii) rain
b) A does not have a definite volume but C does.
c) It ensures a constant supply of fresh water.

37) a) The water enters the jar.

b) The oxygen in the jar was used up so there was space for the water.

38) a)

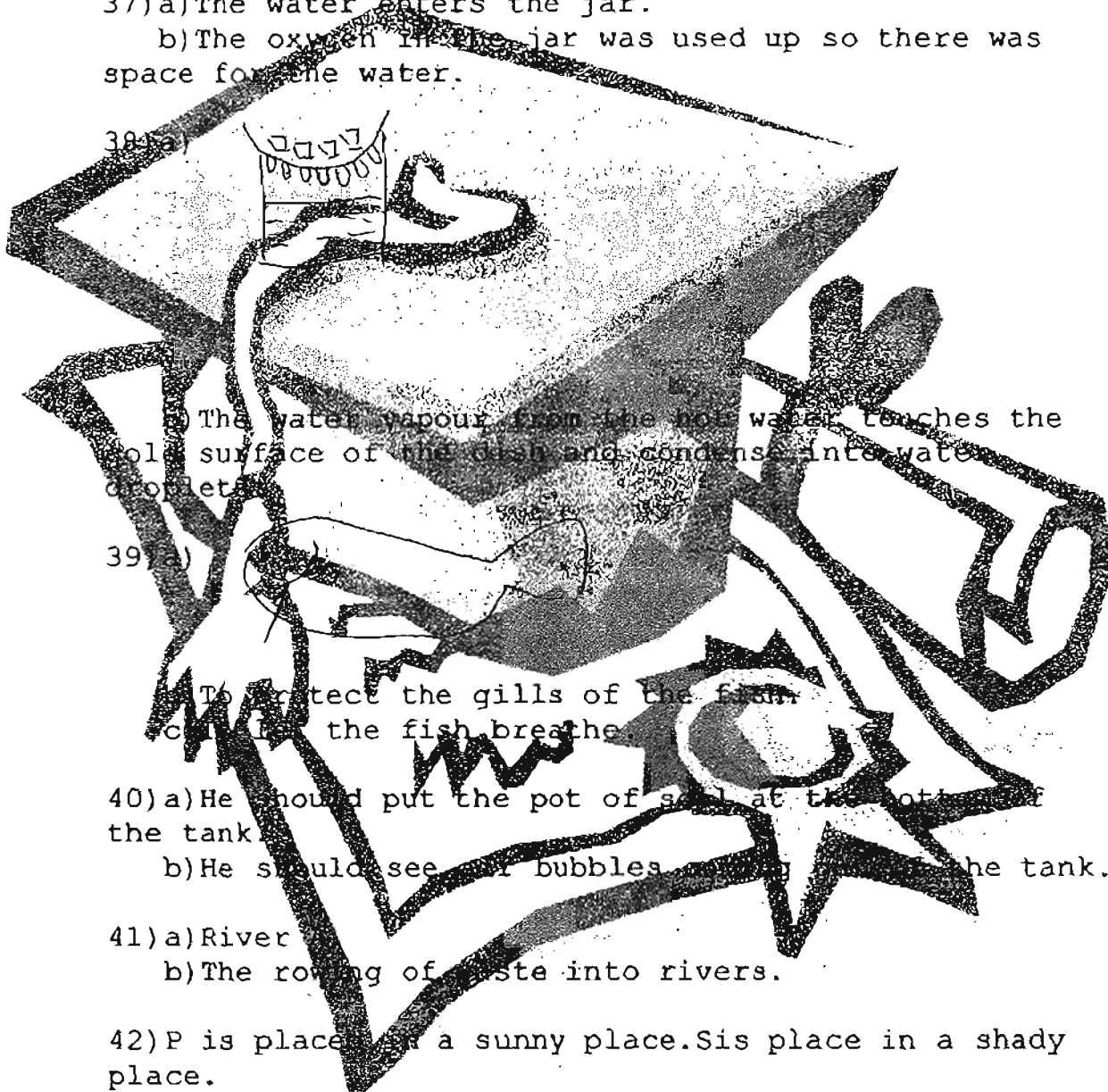

b) The water vapour from the hot water touches the cold surface of the dish and condense into water droplets.

39) a)

b) To protect the gills of the fish.
c) In the fish breathe.

40) a) He should put the pot of soil at the bottom of the tank.

b) He should see if bubbles come out of the tank.

41) a) River

b) The rotting of waste into rivers.

42) P is placed in a sunny place. S is place in a shady place.

43) a) In both processes water changes from a Liquid to a gas.

b) Process A takes place at a fixed temperature while process B takes place at any temperature.

44) a) i) Plastic ii) Iron

b) Magnetism can pass through non-magnetic materials.

45) a) The air in the balloon cannot be compressed any more.

b) Air can be compressed until a certain point.

46) a) Carbon dioxide.

b) It is used to make fizzy drinks.

c) Nitrogen.