



Anglo-Chinese School (Primary)

**MID-YEAR EXAMINATION 2015
SCIENCE
PRIMARY FOUR
BOOKLET A**

Name: _____ . ()

Class: Primary 4 ____

Date: 6 May 2015

Duration of paper: 1 h 45 min

Parent's/Guardian's signature

INSTRUCTION TO CANDIDATES

1. This question paper consists of **18** printed pages including this cover page.
2. Do not turn this page until you are told to do so.
3. Follow all instructions carefully.
4. Answer all questions.
5. Shade your answer on the Optical Answer Sheet (OAS) provided.

For each of the following questions from 1 to 30, four options are given. One of them is the correct answer. Make your choice (1, 2, 3 or 4). Shade the correct oval (1, 2, 3 or 4) on the Optical Answer Sheet. [60 marks]

- 1 Kingsley observed two animals, P and Q, and recorded his observations in the table below.

Characteristics	Animal P	Animal Q
Has gills?	No	Yes
Has legs?	Yes	No
Has wings?	Yes	No
Gives birth to its young alive?	No	No

Which one of the following best represents animals P and Q?

	Animal P	Animal Q
1)	Mammal	Fish
2)	Insect	Bird
3)	Bird	Fish
4)	Mammal	Insect

- 2 Olivia saw an organism. She wanted to find out whether it is an insect. Which of the following actions would enable her to do so?

- A Measure its length.
- B Count the number of legs.
- C Find out whether it has wings.
- D Find out whether it has three body parts.

- 1) A and B only
- 2) B and C only
- 3) A and C only
- 4) B and D only

(Go on to the next page)

3 Kenneth wants to find out if the amount of light would affect the growth of fungi. He prepared two set-ups and listed the following variables that may affect the results of his experiment.

- A The amount of air present in the surroundings
- B The amount of light present in the surroundings
- C The amount of moisture present in the surroundings

Which of the above variable(s) must Kenneth keep the same for the two set-ups to ensure a fair test?

- 1) A only
- 2) B only
- 3) A and C only
- 4) B and C only

4 Mrs Loo has some flowering plants in her garden. She is able to tell that the plants are flowering because they have _____.

- (1) fruits
- (2) woody stems
- (3) spore bags on their leaves
- (4) different leaf shapes and veins

- 5 Study the human body system below.

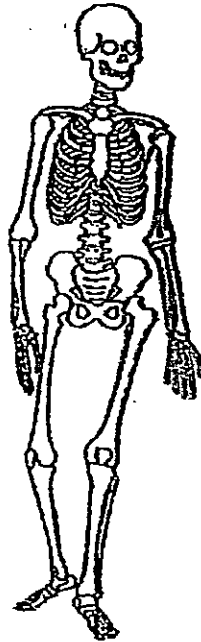

Which one of the following statements is **not** true about the above human body system?

- 1) It supports the body.
- 2) It gives the body shape.
- 3) It takes oxygen into the body.
- 4) It protects the heart and lungs.

- 6 Which one of the following statements describes the main function of the large intestine in our body?

- (1) It breaks down food into simpler forms.
- (2) It passes the digested food to the blood.
- (3) It absorbs water from the undigested food.
- (4) It passes the undigested food out of the body.

(Go on to the next page)

- 7 Michael brought one end of a bar magnet near objects X, Y and Z one at a time.

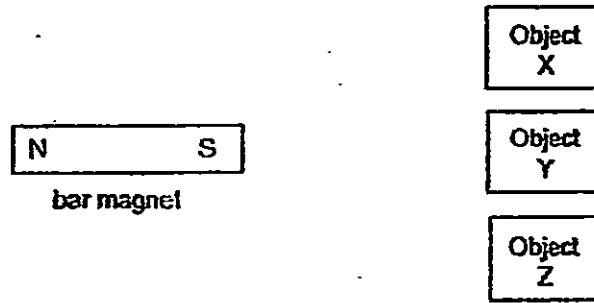

He recorded his observations below.

- A Object X was repelled by the bar magnet.
- B Object Y was attracted by the bar magnet.
- C Object Z did not move when it was brought near the bar magnet.

Based on his observations, which of the following is(are) definitely a magnet(s)?

- (1) Object X only
 - (2) Object Z only
 - (3) Objects X and Y only
 - (4) Objects Y and Z only
- 8 The diagram shown below illustrates a lever balance. Both Object A and Object B are the same distance away from the ground.

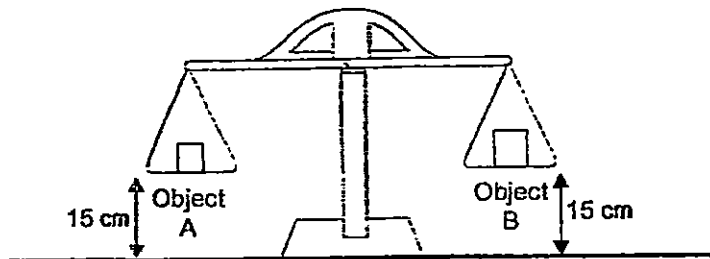

Which one of the following statements is true?

- (1) Object A has a greater mass than Object B.
- (2) Object B has a greater mass than Object A.
- (3) Objects A and B have the same volume.
- (4) Objects A and B have the same mass.

(Go on to the next page)

- 9 Janet made electromagnets using set-ups A, B and C as shown below. The batteries, iron rods and wires used were identical and in working conditions.

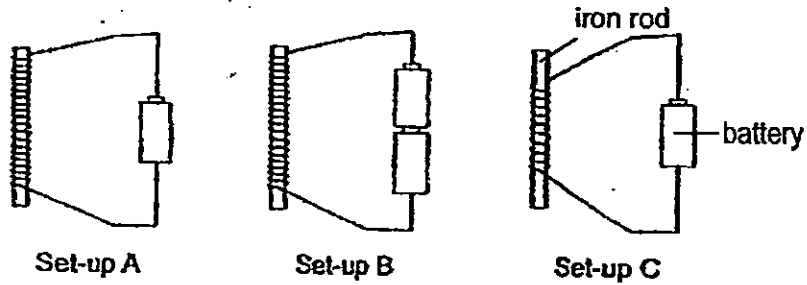

She then arranged the set-ups A, B and C from the one that attracts the most number of paper clips to the one that attracts the least number of paper clips.

Which one of the following shows the correct order?

	Attracts the most number of paper clips	→	Attracts the least number of paper clips
(1)	A	B	C
(2)	B	A	C
(3)	C	A	B
(4)	C	B	A

- 10 Which one of the following pair of items has been grouped correctly?

	Matter	Non-matter
1)	Heat	Stone
2)	Oxygen	Sound
3)	Rainbow	Shadow
4)	Water vapour	Milk

(Go on to the next page)

- 11 Ravi wanted to find out the strength of four different types of paper, W, X, Y and Z. They were all of the same size and thickness. He hung each piece of paper, one at a time, using the following set-up as shown below.

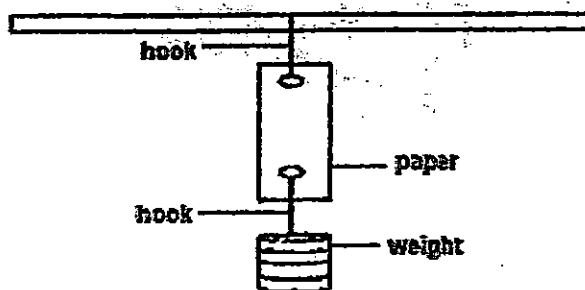

He placed one weight at a time to the lower hook until the paper started to tear and recorded his results as shown in the graph below.

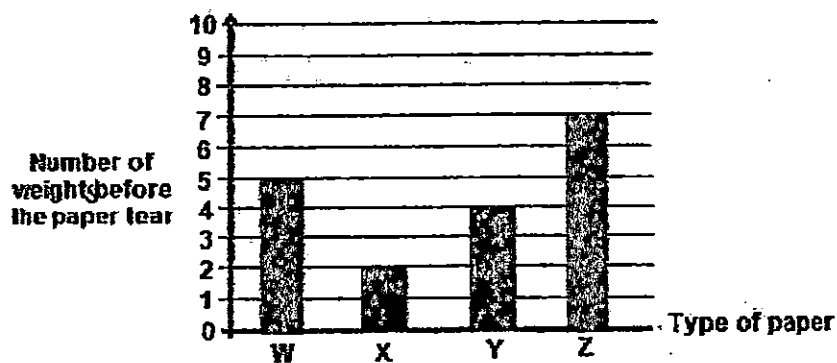

Based on the information above, which of the following statement(s) is/are correct?

- A Y is stronger than Z.
 B Z is the strongest paper.
 C W is stronger than X and Y.
 D X is stronger than W and Y.
- 1) B only
 2) B and C only
 3) A and D only
 4) A and C only

(Go on to the next page)

- 12 Study the diagram below.

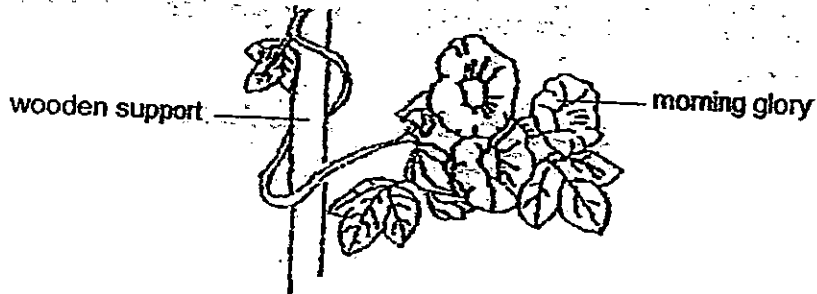

Based on the diagram above, which one of the following statements describes the morning glory?

- 1) The morning glory has a weak stem and is a flowering plant.
- 2) The morning glory has a strong stem and is a flowering plant.
- 3) The morning glory has a weak stem and is a non-flowering plant.
- 4) The morning glory has a strong stem and is a non-flowering plant.

- 13 Study the diagram below.

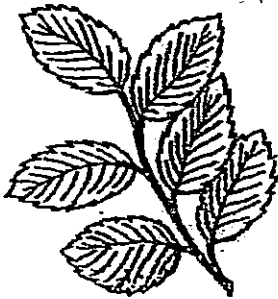

Based on the diagram above, which of the following describes the leaves?

	Leaf edge	Vein pattern
(1)	Jagged	Parallel
(2)	Entire	Network
(3)	Jagged	Network
(4)	Entire	Parallel

(Go on to the next page)

- 14 Eric conducted several tests on a material, Q. He recorded his observation in the table below.

Observation	Material Q
Bends easily?	Yes
Absorbs water?	Yes
Breaks when dropped?	No

Which one of the following is material Q likely to be?

- (1) Rubber
 - (2) Metal
 - (3) Ceramic
 - (4) Fabric
- 15 A stone was dropped into a beaker of water as shown in the diagram below. It was observed that the level of water rose.

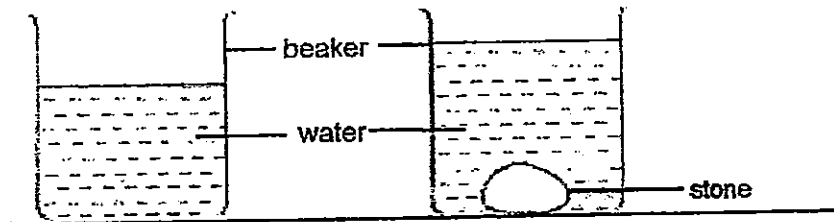

What can be concluded from the experiment above?

- 1) The stone has mass.
- 2) The stone has no volume.
- 3) The stone occupies space.
- 4) The stone has the same volume as the water in the beaker.

(Go on to the next page)

- 16 Study the information provided below.

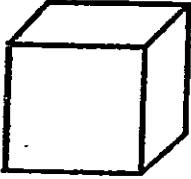
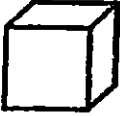
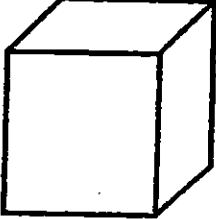
		
Box P	Box Q	Box R
Mass: 240 g Volume: 110 cm ³	Mass: 360 g Volume: 60 cm ³	Mass: 180 g Volume: 200 cm ³

Based on the information given above, which of the following statements are true?

- A Box R has less mass than Box Q.
- B Box R has the most mass as it is the biggest box.
- C Box P occupies more space than Box Q.

- 1) A and B only
 - 2) A and C only
 - 3) B and C only
 - 4) A, B and C
- 17 Darryl placed three different objects, E, F and G, two at a time, using a lever balance. The results are as shown below.

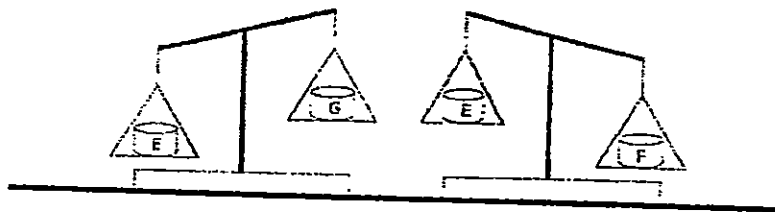

Arrange the objects, E, F and G, in descending order, according to their masses.

- (1) F, G, E
- (2) F, E, G
- (3) G, E, F
- (4) G, F, E

(Go on to the next page)

- 18 120 ml of coloured water from Container A was poured into Container B. The coloured water was then poured from Container B to Container C. There was no spillage.

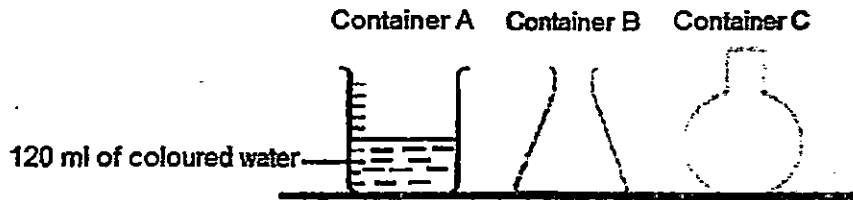

What can be concluded from the above experiment?

- (1) The volume of the coloured water changed but not the mass.
 - (2) The mass of the coloured water changed but not the volume.
 - (3) The shape of the coloured water changed but not the volume.
 - (4) The shape and volume of the coloured water remained the same.
- 19 Four syringes of the same size were filled with different substances of the same volume. A stopper was inserted at the nozzle of each syringe. Which plunger can be pushed in?

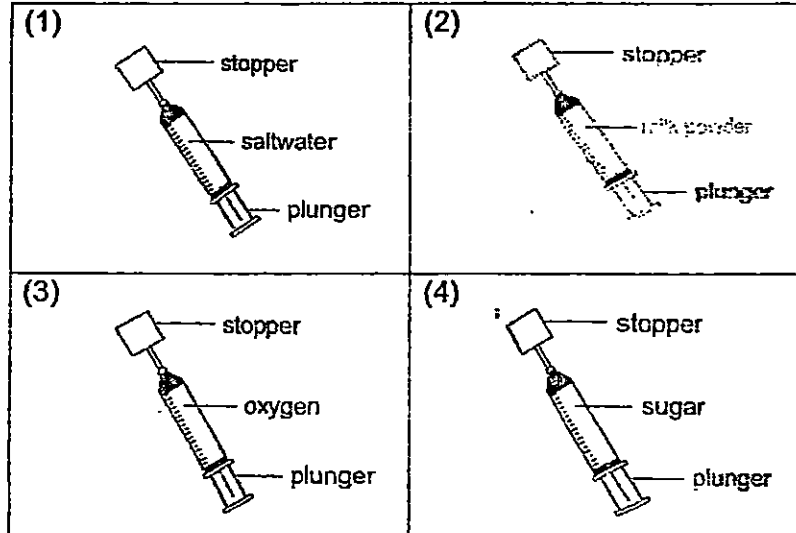

(Go on to the next page)

- 20 The capacity of a rubber ball is 500 cm^3 . The rubber ball was first deflated. An air pump was then used to inflate the rubber ball. Each push of the pump forced 110 cm^3 of air into the ball. What was the volume of air in the rubber ball if the pump was pushed five times?

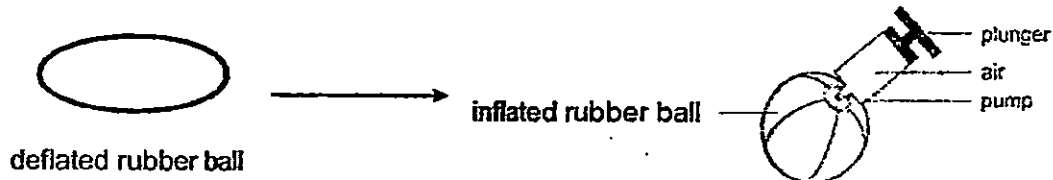

- (1) 110 cm^3
 (2) 390 cm^3
 (3) 500 cm^3
 (4) 550 cm^3
- 21 Fred conducted an experiment to find out the properties of an object. He then recorded his findings in a table as shown below.

Properties	Yes / No
Does the object have a definite volume?	Yes
Does the object have a definite shape?	No
Can the object be compressed?	No

What was most likely the object that Fred was experimenting with?

- (1) salt
 (2) jelly
 (3) paper cup
 (4) sugar syrup

- 22 James set up an experiment as shown below.

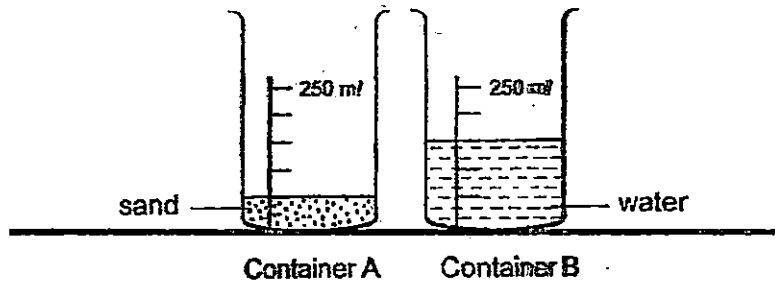

He poured all the water from Container B into Container A. Which one of the following diagrams shows the results of his experiment?

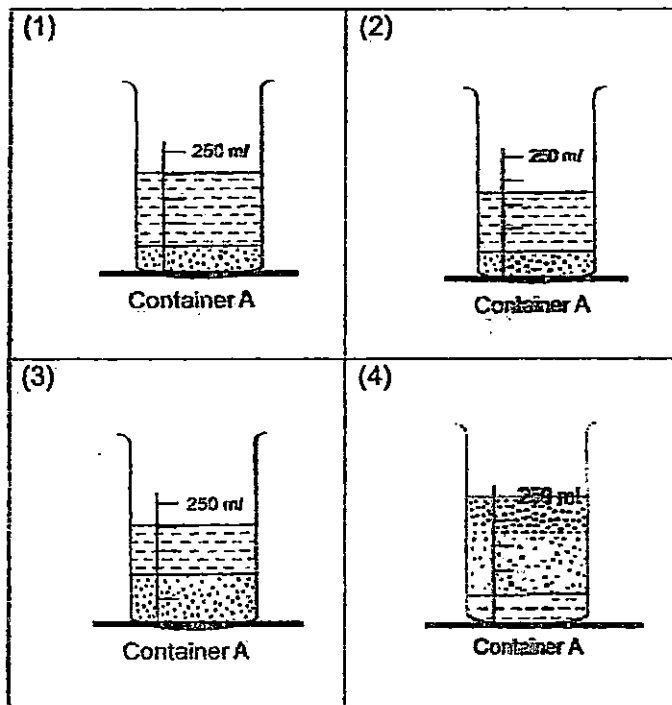

(Go on to the next page)

- 23 An equal amount of water of different temperatures was poured into two identical beakers as shown below. Water from Beaker E was then poured into Beaker F.

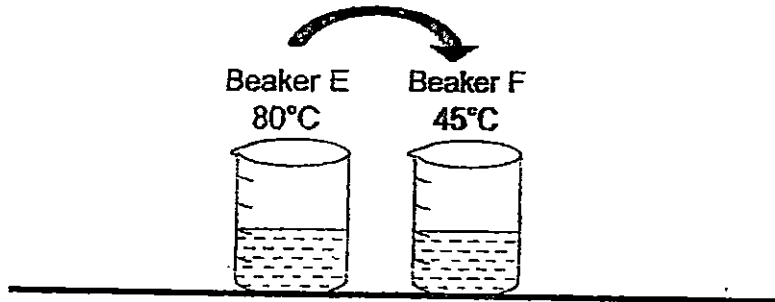

What is the most likely final temperature of the water in Beaker F?

- (1) 45°C
 - (2) 70°C
 - (3) 80°C
 - (4) 100°C
- 24 Four identical mugs of water were left on a table at room temperature as shown below.

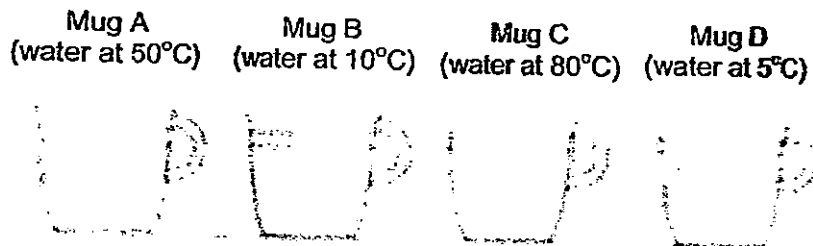

Which mugs lost heat to the surrounding air?

- (1) A and B only
- (2) A and C only
- (3) B and C only
- (4) B and D only

(Go on to the next page)

- 25 Four metal buttons, A, B, C and D, were attached to the metal ring with the same amount of wax as shown in the diagram below.

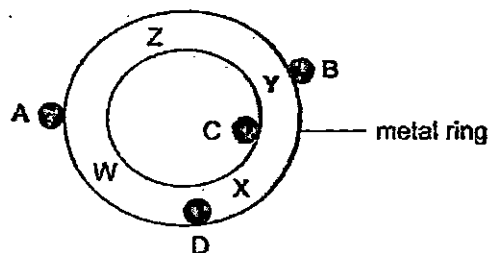

When the metal ring was heated by a lit candle at one part, the metal buttons dropped in the order of B, C, D and A. At which position, W, X, Y or Z, was the lit candle heating the metal ring?

- (1) W
 - (2) X
 - (3) Y
 - (4) Z
- 26 A company wants to produce frying pans. It conducted a test on four different metals, S, T, U and V. The metals were heated for 10 minutes. The temperatures of the pans, before and after heating, were recorded. The results of the test are shown in the table below.

Metal	Temperature before heating ($^{\circ}\text{C}$)	Temperature after heating ($^{\circ}\text{C}$)
S	25	59
T	25	62
U	25	55
V	25	70

Based on the results above, which metal, S, T, U or V, is the most suitable material for making the base of a frying pan?

- (1) S
- (2) T
- (3) U
- (4) V

(Go on to the next page)

- 27 Asher wants to find out which metal bar, E or F, will expand more when heated. Which two set-ups should he use in order to carry out a fair test?

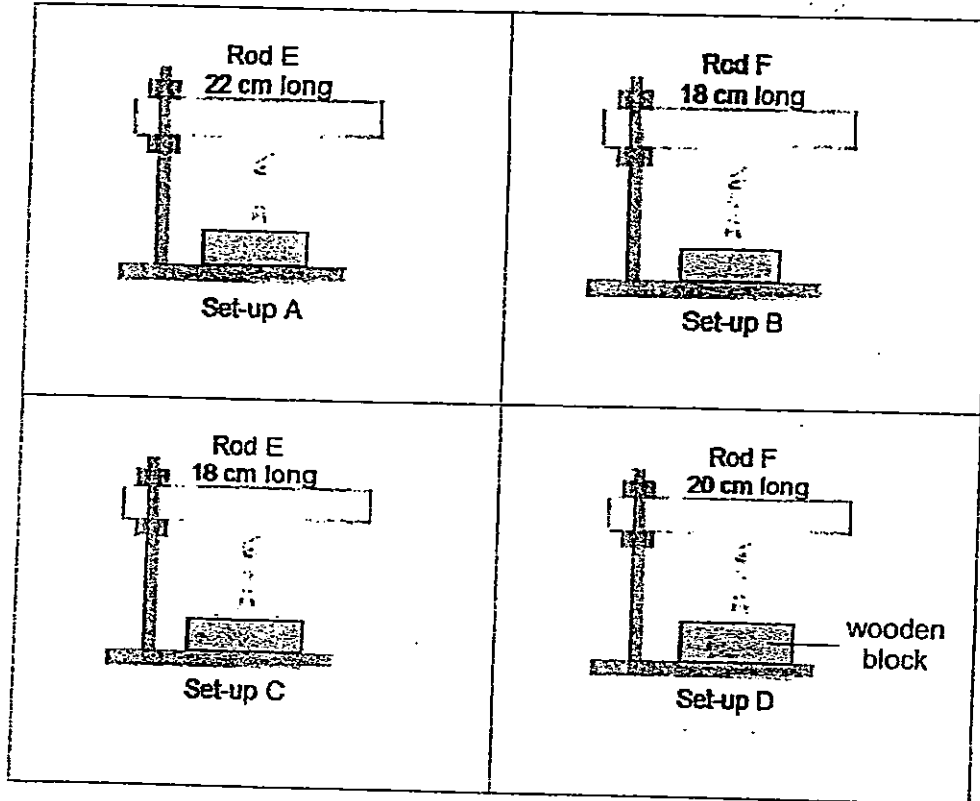

- (1) A and B only
- (2) B and C only
- (3) C and D only
- (4) A and D only

(Go on to the next page)

28 Study the classification diagram below.

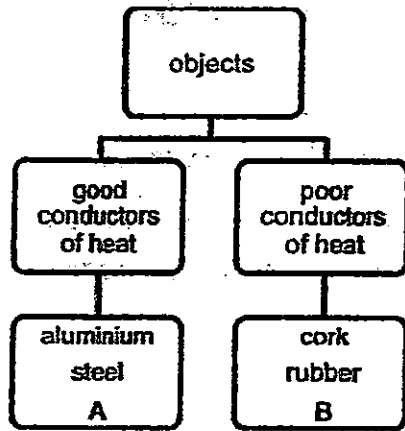

What are objects A and B most likely to be?

	A	B
1)	Wood	Copper
2)	Wood	Air
3)	Air	Copper
4)	Copper	Air

29 Study the diagram below that represents the process of how water can change into its three different states.

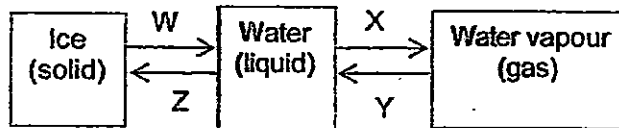

Which of the following shows the correct heat transfer among the three states of matter?

	Heat Gain	Heat Loss
(1)	W and Z	X and Y
(2)	X and Y	W and Z
(3)	W and X	Y and Z
(4)	Y and Z	W and X

(Go on to the next page)

- 30 Ali had difficulty separating two glass cups, A and B, which were stuck together as shown in the diagram below.

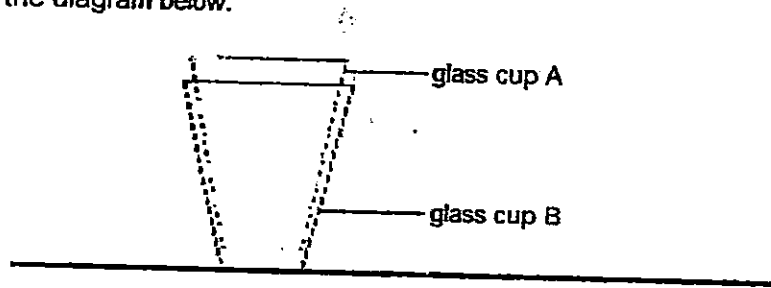

Which one of the following statements is the best solution to separate the two glass cups?

- (1) Put glass cup B in a basin of hot water and put ice cubes into glass cup A.
- (2) Put glass cup B in a basin of cold water and put ice cubes into glass cup A.
- (3) Put glass cup B in a basin of hot water and pour hot water into glass cup A.
- (4) Put glass cup B in a basin of cold water and pour hot water into glass cup A.

END OF BOOKLET A

Please go on to Booklet B



Anglo-Chinese School (Primary)

MID-YEAR EXAMINATION 2015
SCIENCE
PRIMARY FOUR
BOOKLET B

Name: _____ ()

Class: Primary 4 ____

Date: 6 May 2015

Duration of paper: 1 h 45 min

Parent's/Guardian's signature

INSTRUCTIONS TO CANDIDATES

1. This question paper consists of 13 printed pages including this cover page.
2. Do not turn over this page until you are told to do so.
3. Follow all instructions carefully.
4. Answer all questions.
5. Write your answers in this booklet.

Booklet	Maximum marks	Marks obtained
A	60	
B	40	
Total	100	

For questions 31 to 44, write your answers in the spaces provided in this booklet.

The number of marks available is shown in the brackets [] at the end of each question or part question. (40 marks)

- 31 Put a tick (✓) in the appropriate boxes to indicate if each statement about fungi is true or false. [2]

Statements	True	False
Fungi cannot make their own food.		
Fungi exist as micro-organism only.		
Fungi produce spores for reproduction.		
Fungi have true roots to help them absorb water.		

- 32 The diagram below shows a mushroom.

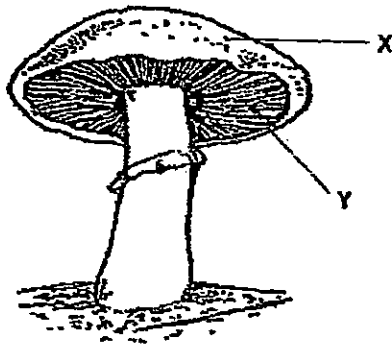

Identify parts X and Y.

(a) X: _____ [1]

(b) Y: _____ [1]

(Go on to the next page)

Score	4
-------	---

- 33 The diagram below shows the human digestive system.

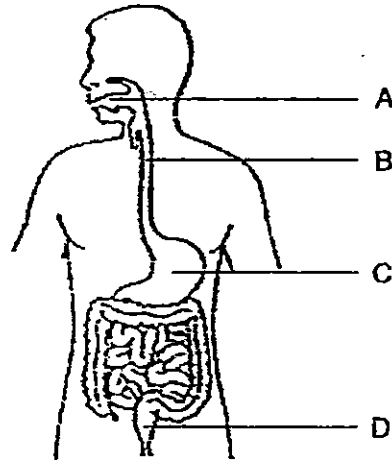

- (a) State two of the parts (A, B, C, D) where digestion take place [2]

Kumar used some scrap materials to make a model of the digestive system as shown below.

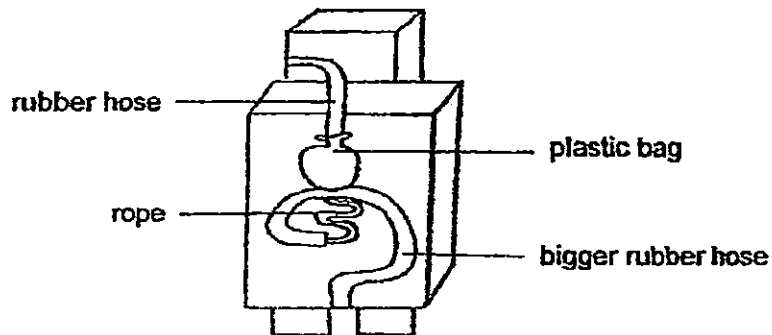

- (b) Name the parts of the digestive system represented by each of the scrap materials used. [2]

(i) rubber hose: _____

(ii) plastic bag: _____

(Go on to the next page)

Score	4
-------	---

34 The diagram below shows the greatest distance from which the different magnets, P and Q, will be able to attract the paper clip K.

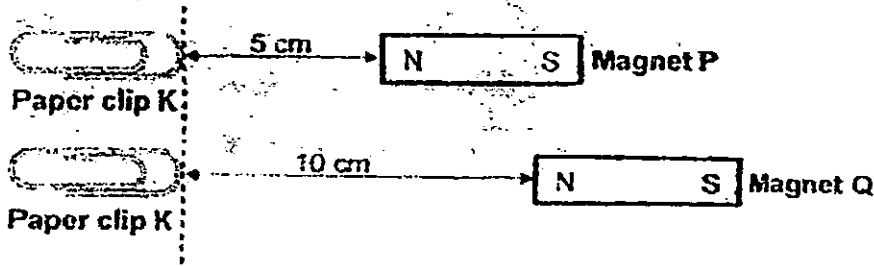

(a) What can you conclude from the above experiment? [1]

(b) Put a tick (✓) in the appropriate boxes to indicate which variable(s) to change or keep the same to ensure a fair test in the experiment above. [1]

Variable	Change	Keep the same
Size of paper clip		
Type of magnet		
Size of magnet		
Position where the paper clip is placed		

(c) State one way to make a magnet weaken or loses its magnetism. [1]

(Go on to the next page)

Score	2
	3

- 35 Aaron used two similar plants to conduct an experiment as shown below. He removed the roots of the plant in Set-up 1, and left both plants in a room in the same location.

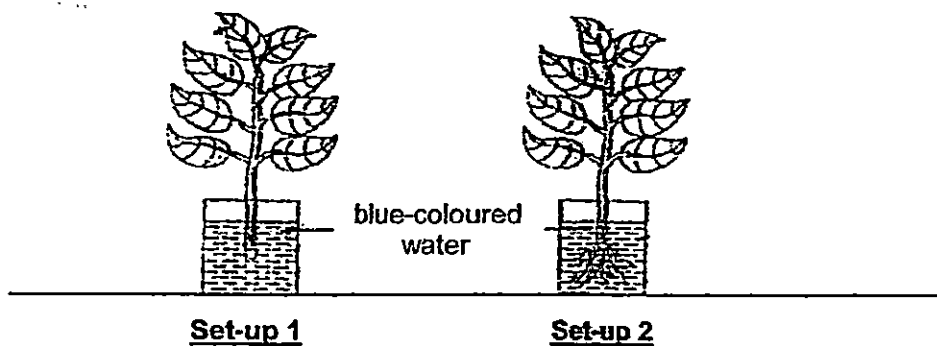

After eight hours, he measured the amount of water left in each set-up, and recorded his results in table below.

Set-up	Amount of water at the start of the experiment	Amount of water at the end of the experiment
1	500 ml	420 ml
2	500 ml	340 ml

- (a) What was the aim of Aaron's experiment? [1]

- (b) State the two main functions of the stem in a plant [2]

(i) _____

(ii) _____

(Go on to the next page)

Score	3
-------	---

36 Study the flowchart below.

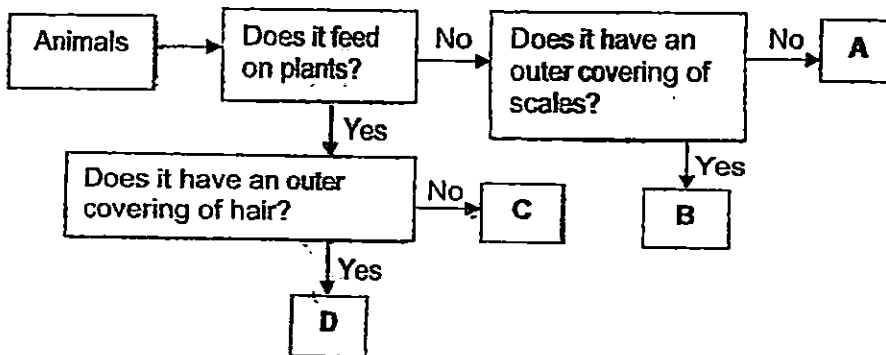

- (a) Lucas was given a pet animal with hairs on its body and it feeds on plants. Based on the classification diagram, which one of the animals, A, B, C or D, represents Lucas's pet animal? [1]
-
- (b) Based on the flowchart above, which letter, A, B, C and D, correctly represents each of the animals below. [2]

	Animal	Letter
(i)	tiger	
(ii)	horse	
(iii)	crocodile	
(iv)	grasshopper	

(Go on to the next page)

Score	3
-------	---

37 Study the flowchart below carefully.

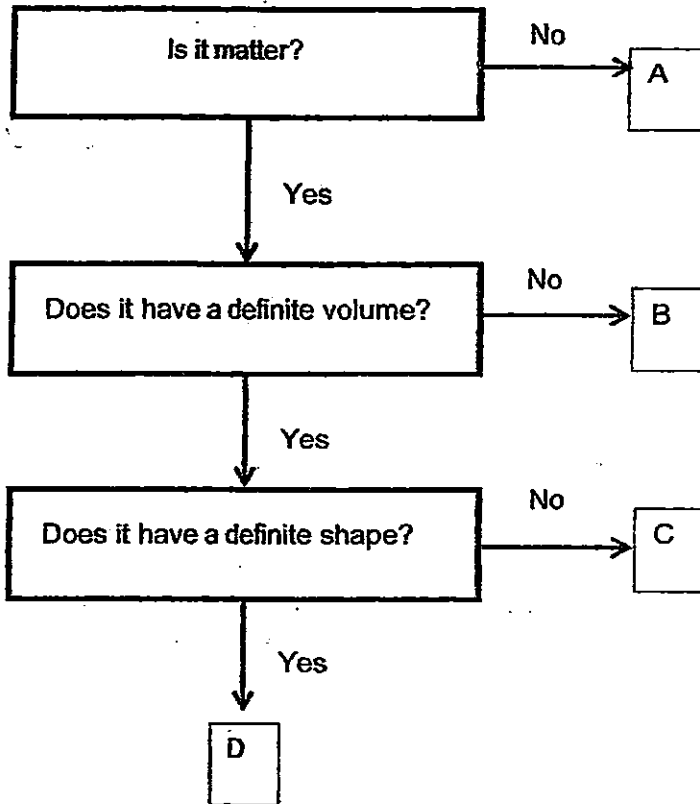

Using the flowchart above, which letter best represents the following items?

[2]

Item	Letter
Air	
Heat	
Bottle	
Orange juice	

(Go on to the next page)

Score	2
-------	---

- 38 Zachary squeezed a lump of plasticine into a bottle as shown below. He managed to squeeze it in.

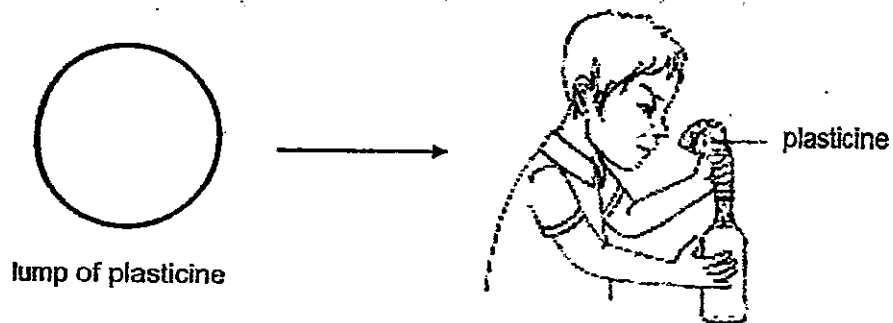

- (a) Which state of matter is plasticine in? [1]

- (b) Zachary then moulded the plasticine into different shapes, one at a time. He made sure that all the plasticine was used every time. State the mass and volume for each shape of plasticine that he has moulded. [2]

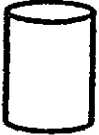
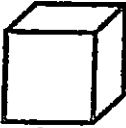
Shape	Mass (g)	Volume (cm ³)
 Lump of plasticine	25	35
 cylinder		
 box		

(Go on to the next page)

Score	3
-------	---

- 39 An empty plastic bottle was inverted into a glass tank filled with water. The bottle was then given a tight squeeze and released.

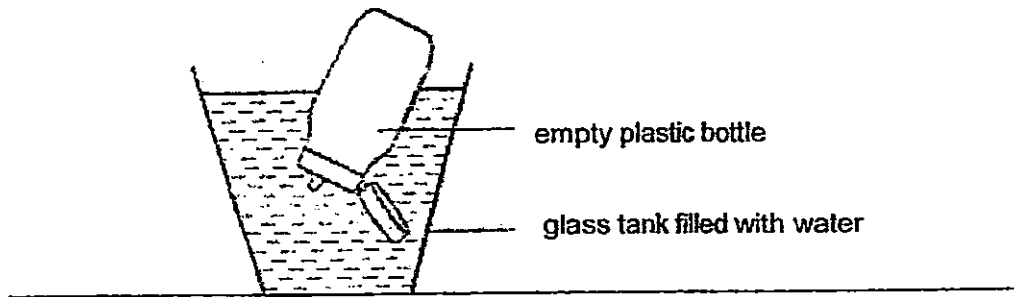

- (a) What was observed at the mouth of the plastic bottle when it was squeezed? [1]
-
- (b) Explain your answer to (a). [1]
-
- (c) What was observed about the level of water in the plastic bottle when it was released? [1]
-

(Go on to the next page)

Score	3
-------	---

40 Two boys, Mark and Tom, conducted two experiments with the same aim. Mark set up an experiment as shown in the diagram below to find out which metal pole, E, F or G, expands the most when heated. However, he did not carry out a fair test.

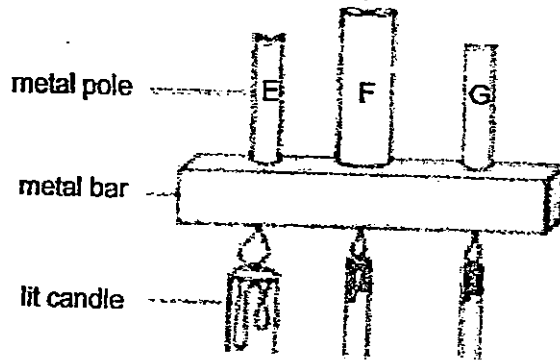

(a) Which variable(s) should Mark have kept constant in order to conduct a fair experiment? Put a tick (✓) next to the variable(s). [1]

Variable	To be kept constant
Size of metal poles	
Type of metals	
Size of candles	

The other boy, Tom, conducted the experiment correctly. The results of his test are illustrated in the graph below.

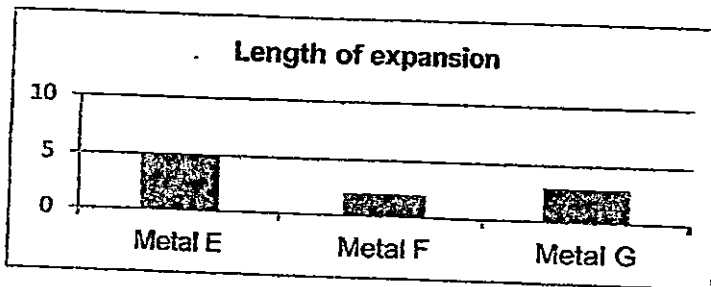

(b) A company wants to make railway tracks. Based on this experiment, which metal, E, F or G, should the company use to make the railway tracks so that it doesn't buckle on a hot day? [1]

(c) Explain your answer to part (b). [1]

(Go on to the next page)

Score	3
-------	---

- 41 Martin secured a deflated balloon over the mouth of a plastic bottle. He then blew air into the balloon. However, he realised that it was impossible to inflate the balloon.

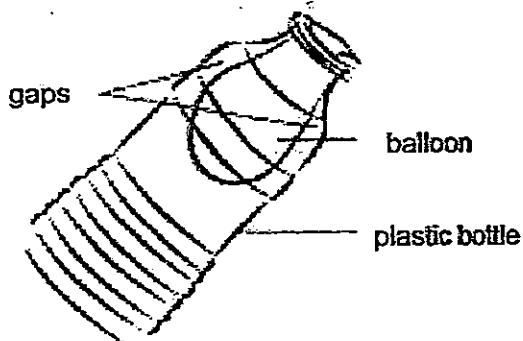

- (a) Why was it not possible to inflate the balloon? [1]

- (b) After Martin poked a hole on the bottom of the plastic bottle, the balloon could be inflated. Why was this so? [2]

- 42 Ethan wanted to find out the volume of a pebble. He conducted the experiment and the steps he took were listed below.

- (a) Number the steps taken accordingly. Step 1 has been stated. [2]

Procedure	Step
Fill the measuring cylinder with 20 ml of water.	1
Record the total volume of the water and the pebble in the measuring cylinder.	
Repeat the procedure for two more times.	
Place the pebble in the measuring cylinder carefully, ensuring that the water doesn't splash out, and the pebble is fully submerged.	
Find the difference between the volume of the water and the pebble, and the original volume of water in the measuring cylinder.	

- (b) Why is there a need to repeat the procedure more than once? [1]

(Go on to the next page)

Score	6
-------	---

- 43 A balloon was attached to the mouth of an empty flask and suspended on a retort stand as shown below. The flask was placed above a bunsen burner and heated for a few minutes. It was observed that the balloon became inflated.

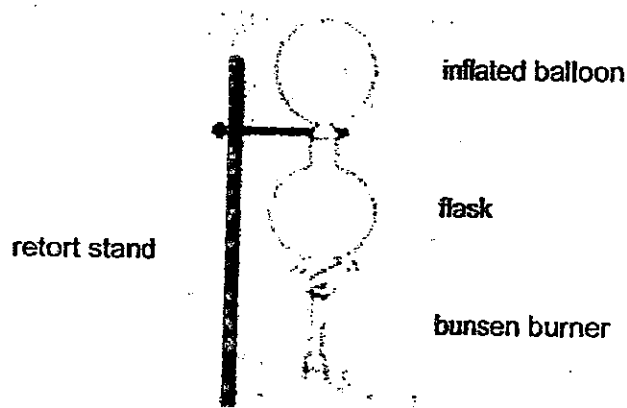

- (a) What was the aim of the experiment? [1]

- (b) A hot air balloon requires its material to stretch fairly well when it is heated. Explain why such a material is needed to create the hot air balloon. [1]

A test was conducted on three different materials to determine their ability to stretch. The results are shown in the table below.

Material	Total length of stretch made (cm)
Cotton	2
Leather	4
Nylon	8

- (c) Based on the above results, which one of the materials, cotton, leather or nylon, is best suited to create the hot air balloon? [1]

(Go on to the next page)

Score	3
-------	---

- 44 Classify the list of items below into two groups according to whether they are good conductors of heat or poor conductors of heat. [3]

Aluminium	Steel	Rubber
Plastic	Styrofoam	Iron

Good conductors of heat	Poor conductors of heat

END OF BOOKLET B

Please check all your answers carefully

Score	3
-------	---

Primary School Test Paper Singapore

Save Your Money, Save Your Time, No More Worries

Powered by www.testpaper.biz



LEVEL : PRIMARY 4
SCHOOL : ANGLO CHINESE SCHOOL PRIMARY (BAKER ROAD)
SUBJECT : SCIENCE
TERM : SA1

Q 1	Q 2	Q 3	Q 4	Q 5	Q 6	Q 7	Q 8	Q 9	Q 10
3	4	3	1	3	3	1	4	2	2
Q 11	Q 12	Q 13	Q 14	Q 15	Q 16	Q 17	Q 18	Q 19	Q 20
2	1	3	4	3	2	2	3	3	3
Q 21	Q 22	Q 23	Q 24	Q 25	Q 26	Q 27	Q 28	Q 29	Q 30
4	2	2	2	3	4	2	4	3	1

Q31. TRUE, FALSE, TRUE, FALSE

Q32. X: Spore caps Y: Gills

Q33a. A & C

Q33bi) rubber hose : gullet Q33bii) plastic bag: stomach

Q34a. Magnet Q has a stronger magnetic force than magnet P.

Q34b.

Variable	change	Keep the same
Size of paper clip		✓
Type of magnet	✓	
Size of magnet		✓
Position where the paper clip is placed		✓

Q34c. Heating can make a magnet weakens or loses its magnetism.

Q35a. To find out if the plant with roots take in more water.

Q35bi) To support the plant. Q35bii) To transports food and minerals to the rest of the plants.

Q36a. D Q36bi) A Q36bii) D Q36biii) B Q36biv) C

Q37. Air - B, Heat - A, Bottle - D, Orange juice - C

Q38a. Solid

Q38b. Cylinder - mass 25g Volume - 35cm³

Q38b. Box - 25g Volume - 35cm³

Q39a. Air bubbles were forced out of the water.

Q39b. When the person squeezed the bubbles out of the bottle.

Q39c. The level of water increased.

Q40a

Variable	To be kept constant
Size of metal poles	✓
Type of metals	
Size of candles	✓

Q40b. Metals

Q40c. Metal F expanded the least.

Q41a. The air in the plastic bottle occupied space

Q41b. As the balloon occupied more space, the air in the bottle can escape.

Q42a. 1, 3, 5, 2, 4

Q42b. To reduce experimental error.

Q43a. To find out if air expands when it is heated. Q43b. The material must be able to stretch as it will expand when the material gains heat from the hot air. Otherwise, the material will tear.

Q43c. Nylon

Q44.

Good conductors of heat	Poor conductors of heat
Iron	plastic
nickel	styrofoam
silver	wool

**ANGLO-CHINESE SCHOOL
(JUNIOR)**



**SEMESTRAL ASSESSMENT 1 (2015)
PRIMARY 4**

SCIENCE

BOOKLET A

FRIDAY

8 MAY

1 hour 30 minutes

Name : _____ ()

Class : P4 _____

INSTRUCTIONS TO PUPILS

DO NOT TURN OVER THE PAGES UNTIL YOU ARE TOLD TO DO SO

Follow all instructions carefully.

There are 25 questions in this booklet.

Answer **ALL** questions.

INFORMATION FOR PUPILS

The total marks for this booklet is 50.

The total time for Booklets A and B is 1 hour 30 minutes.

This question paper consists of 19 printed pages (inclusive of cover page).

Booklet A (50 marks)

For each question from 1 to 25, four options are given. One of them is the correct answer. Make your choice (1, 2, 3 or 4). Shade your answer on the Optical Answer Sheet.
(25 x 2 marks)

1. Study the things in the box below.

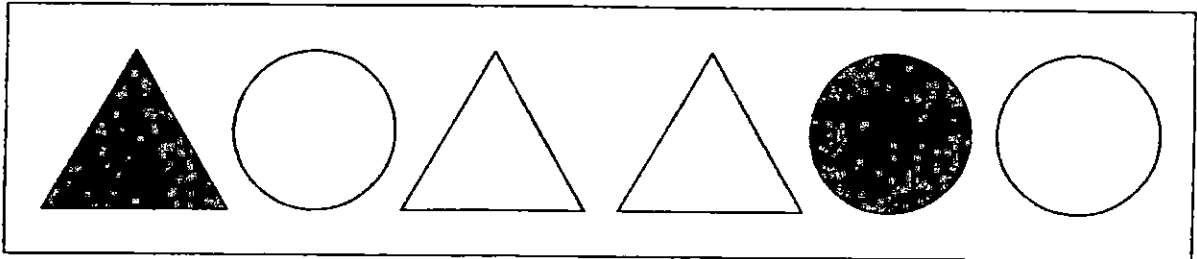

Which of the following classifications can be used to classify the things into two groups?

- A According to size
B According to shape
C According to colour

- (1) B only
(2) A and C only
(3) B and C only
(4) All of the above
2. Study the classification below.

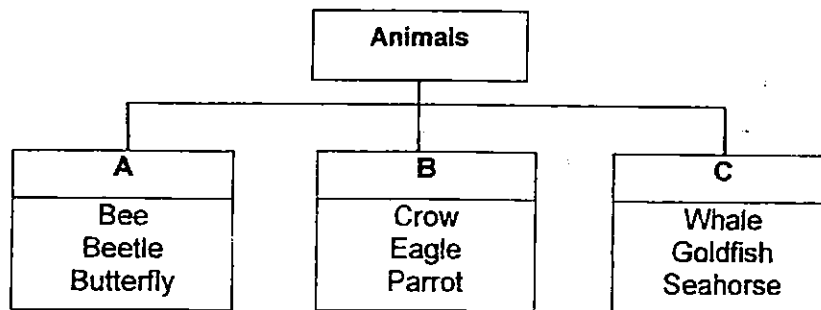

Which of the animals above is incorrectly classified?

- (1) Crow
(2) Whale
(3) Beetle
(4) Seahorse

3. The chart below shows how some organisms are classified.

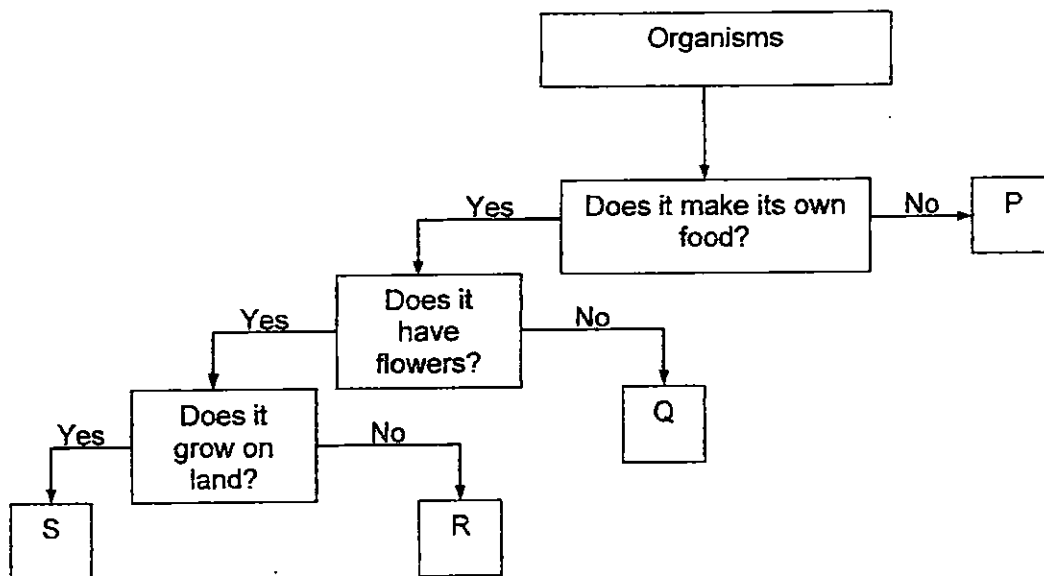

Which of the following best represent P, Q, R and S as shown in the chart above?

	P	Q	R	S
(1)	papaya plant	ladder fern	water hyacinth	sunflower
(2)	mushroom	banana	water lily	balsam
(3)	bracket fungus	moss	balsam	water lily
(4)	toadstool	staghorn fern	lotus	ixora

4. Some pupils made the following statements on fungi and bacteria.

Pupil A: Both fungi and bacteria can be useful to humans.
 Pupil B: Both fungi and bacteria do not make their own food.
 Pupil C: All fungi and bacteria cannot be seen with our naked eyes.
 Pupil D: Fungi feed on dead and living organisms but bacteria feed on living organisms.

Who made the correct statements on fungi and bacteria?

- (1) Pupils A and B
 (2) Pupils C and D
 (3) Pupils A, B and C
 (4) Pupils A, B, C and D

5. Mike carried out an experiment on 4 different types of materials Q, R, S and T. He placed a few drops of water on each material and observed the material.

Material	Observation
Q	The water slowly seeped into the material.
R	The water flowed off the sides of the material.
S	The water was absorbed into the material immediately.
T	The water was absorbed into the material after 5 minutes.

Based on the information above, which of the 4 materials, Q, R, S and T is most suitable to make a raincoat?

- (1) Q
 - (2) R
 - (3) S
 - (4) T
6. Which two body systems work together to supply oxygen to the body?
- (1) Muscular and Skeletal System
 - (2) Digestive and Circulatory System
 - (3) Digestive and Respiratory System
 - (4) Respiratory and Circulatory System

7. Study the classification table below.

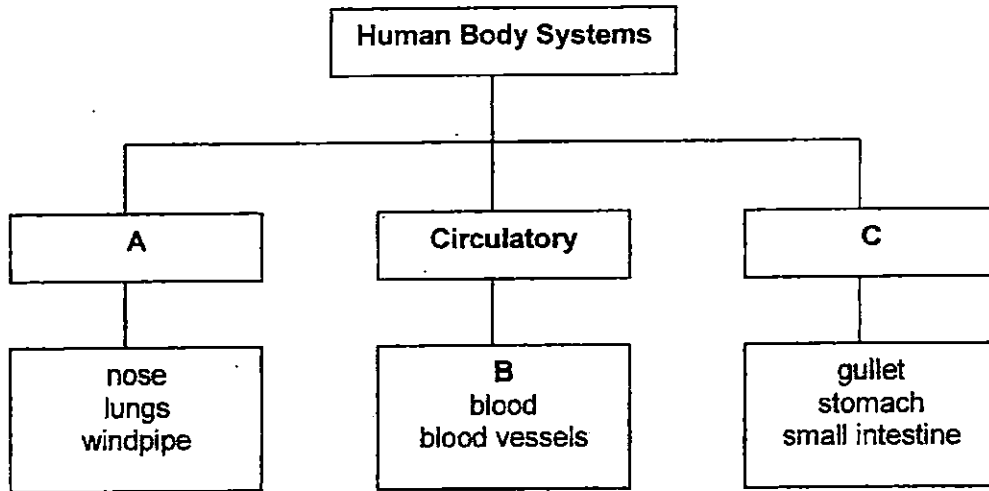

Which one of the following sets matches A, B and C?

	A	B	C
(1)	respiratory system	heart	digestive system
(2)	digestive system	brain	muscular system
(3)	skeletal system	heart	muscular system
(4)	respiratory system	brain	digestive system

8. Study the diagram below.

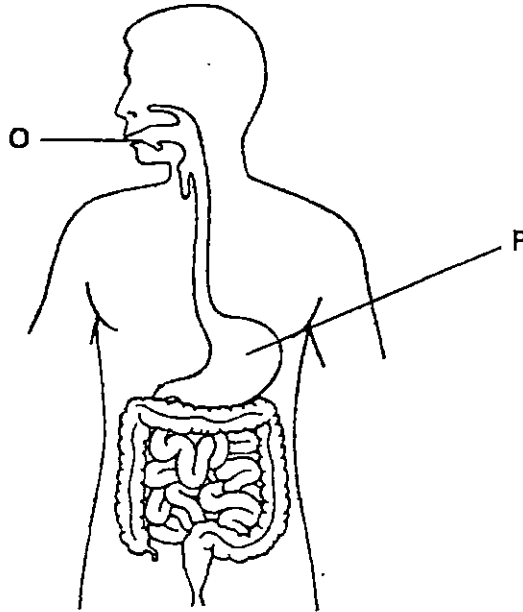

Which of the following correctly describes the functions of parts O and P of the human digestive system?

	Part O	Part P
(1)	Saliva softens and digests the food.	Digested food is absorbed into the blood.
(2)	Food is digested further and mixed with other digestive juices.	Digestion begins here.
(3)	Digested food is absorbed into the blood.	Chewed food is delivered to other parts of the digestive system.
(4)	Food is chewed and ground into smaller pieces.	Food is digested further and mixed with other digestive juices.

9. Aloysius cut off part(s) of a potted plant. He left the plant near the window and watered it daily. One week later, the potted plant died. Which part(s) of the plant did Aloysius cut?

- A Fruits
- B Leaves
- C Flowers

- (1) A only
- (2) B only
- (3) C only
- (4) A and C

10. The diagram below shows two plants.

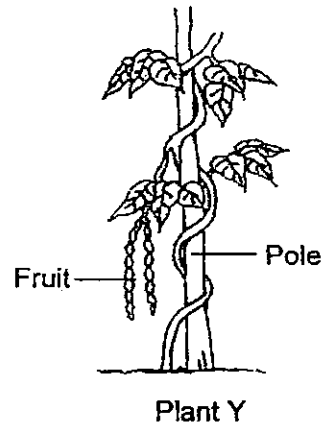
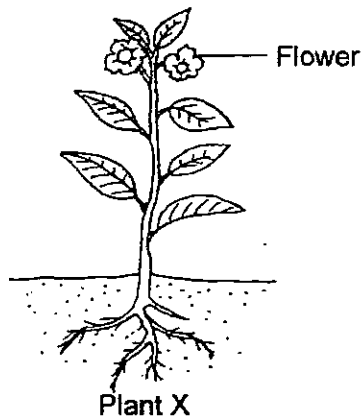

Based on the information given in the diagrams above, which of the following statement(s) is/are true for both plants?

- A They have weak stems.
- B They are flowering plants.
- C They make their own food.

- (1) B only
- (2) A and C only
- (3) B and C only
- (4) A, B and C

11. Amy set up the experiment as shown below.

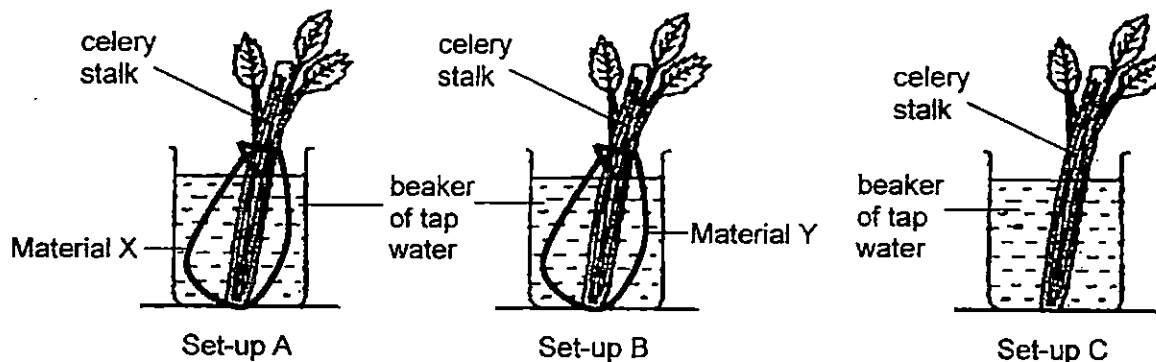

The bases of the celery stalks in set-ups A and B were wrapped with 2 different materials X and Y. Three days later, Amy recorded her observations of the celery stalk in the table below.

	Set-up A	Set-up B	Set-up C
Observation	Leaves are green and firm	Leaves are yellowish and droopy	Leaves are green and firm.

Which of the following statements show the correct conclusion of Amy's experiment?

- A Water can pass through material X.
 - B More water passed through material Y than material X.
 - C The leaves of the celery stalk in set-up B is likely to be firm if the base of the celery stalk was not wrapped with material Y.
- (1) A and B only
 (2) A and C only
 (3) B and C only
 (4) A, B and C

12. John made some observations of the life cycles of a butterfly and a mosquito. He recorded his observation in the table below. He placed a tick (✓) to represent the characteristic that the insect has and a cross (X) to represent the characteristic that the insect does not have.

		Butterfly	Mosquito
A	4 stages in life cycle	✓	X
B	Lays eggs in water	✓	✓
C	The young resembles the adult	X	X
D	It is a pest during the larval stage	✓	X

Which of his observations did John record correctly?

- (1) A and B only
 (2) A and D only
 (3) B and C only
 (4) C and D only
13. The diagram below shows the life cycle of animal X.

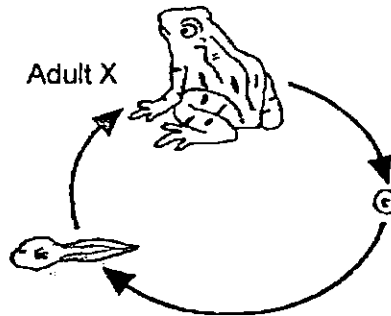

Based on the diagram above, which of the following statements is **not true** about animal X?

- A It gives birth to its young alive.
 B It has three stages in its life cycle.
 C Its young closely resembles its parent.
- (1) A and B only
 (2) A and C only
 (3) B and C only
 (4) A, B and C

14. Ahmad found a young of animal R and observed it over a few days. He recorded his observations in the table below.

It moults.
It eats a lot.
It resembles its adult.
It does not have wings.
It moves around quickly.

Which one of the following animals could the young of animal R most likely be?

- (1) Housefly
 - (2) Mosquito
 - (3) Cockroach
 - (4) Mealworm Beetle
15. Alvin prepared four set-ups, A, B, C and D, using similar types of seeds with different conditions as shown in the table below.

Set- Up	Type of cotton wool	Location
A	moist	in the freezer
B	moist	near a window
C	dry	near a window
D	dry	in the freezer

Which set-ups should Alvin use if he wants to test if seeds need warmth to germinate?

- (1) A and B
- (2) A and C
- (3) A and D
- (4) B and C

16. Which of the following shows the correct order of the stages and process in the life cycle of a flowering plant?

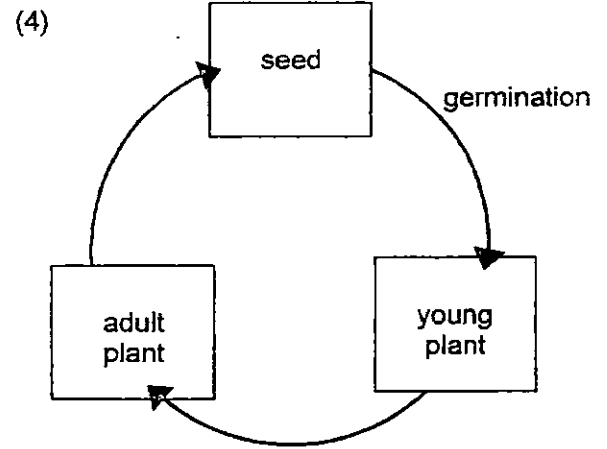
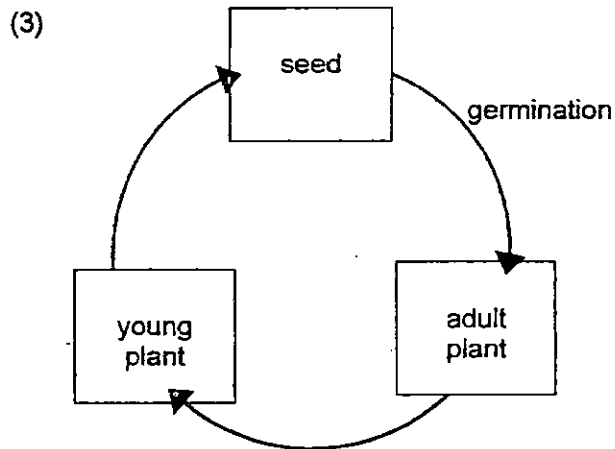
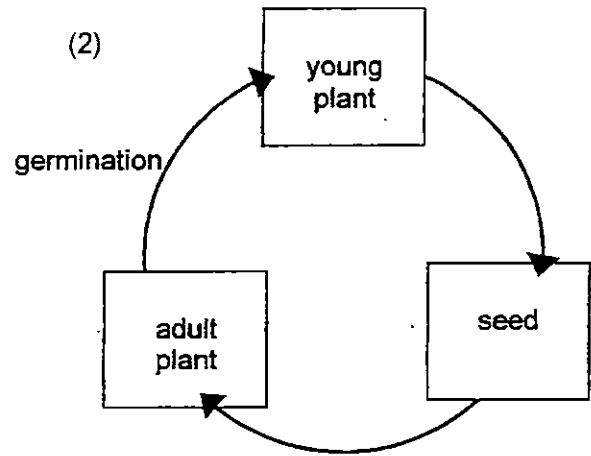
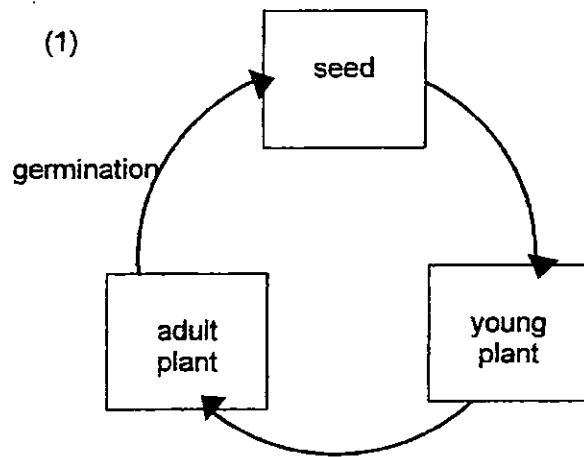

17. Susan observed some green bean seeds germinate and recorded her observations in the table shown below.

Day	Observation
2	The seeds swell
3	The seed ^{seed} coat breaks
4	The roots start to appear
7	The shoots start to appear
14	The shriveled seed leaves have dropped off

From which day onwards will the seedling most likely be able to start to make its own food?

- (1) Day 2
- (2) Day 4
- (3) Day 7
- (4) Day 10

18. Study the classification table below.

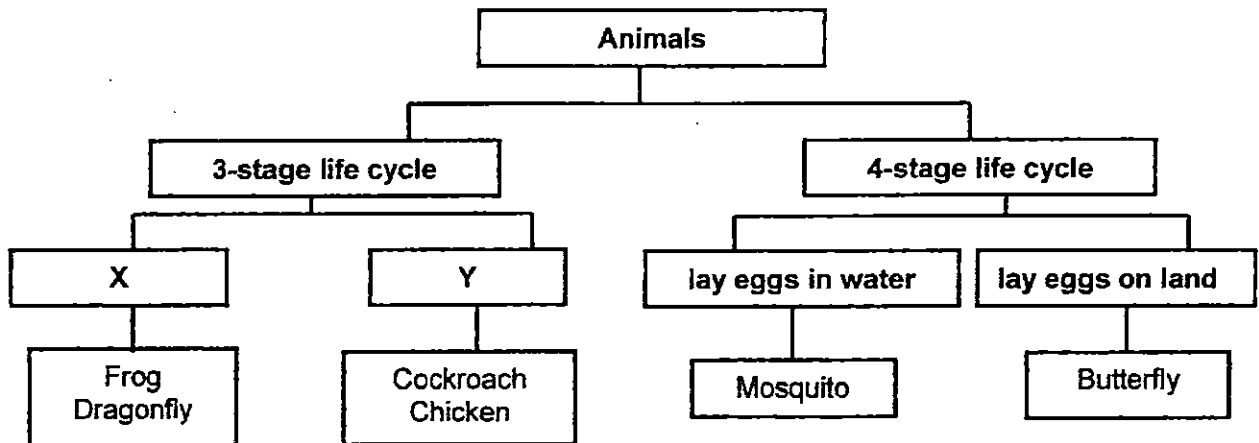

Give a suitable sub-heading for X and Y.

	X	Y
(1)	Lay eggs	Do not lay eggs
(2)	Can fly	Cannot fly
(3)	Breathe through gills	Breathe through lungs
(4)	Spends some parts of its life cycle in water	Spends all its life cycle on land

19. Monica found Plant X, growing in her school garden. She recorded some of her observations below.

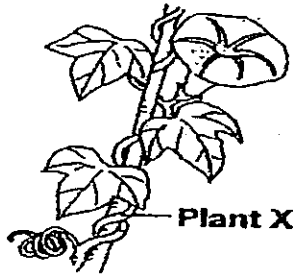

- P The plant has a weak stem.
Q The plant cannot bear fruits.
R The plant grows towards sunlight.
S The stem of the plant holds the plant firmly to the ground.

Which of her observations are correct?

- (1) P and S only
(2) P and R only
(3) Q and R only
(4) Q and S only

20. Mr Raju wanted to pack eight sets of clothing into his luggage bag. However, he found that he can only put in five sets of clothing inside the bag.

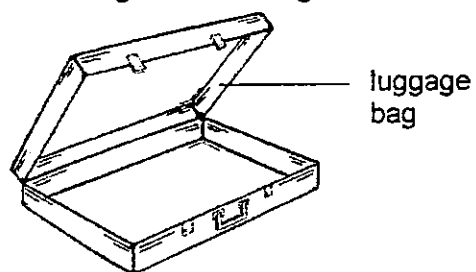

Which of the following best explains why was he unable to pack the remaining three sets of clothing?

- A The clothes are too colorful.
 - B The clothes cannot be compressed.
 - C The clothes do not have a definite volume.
 - D The clothes take up space in the luggage bag.
-
- (1) A and B
 - (2) A and C
 - (3) B and D
 - (4) C and D

21. Wilfred placed three rods on the floor. When he placed a magnet next to the three rods, Rod A and B moved in the direction of the arrow shown in the diagram below. Rod C did not move.

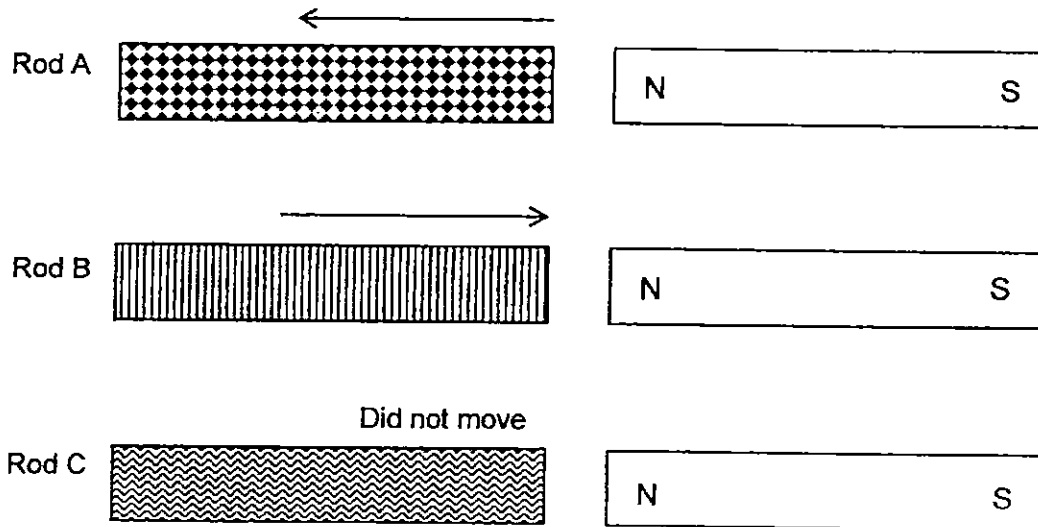

Which of the following rods is/are definitely magnets?

- (1) Rod A only
- (2) Rod B only
- (3) Rod A and Rod C
- (4) Rod B and Rod C

22. The set-up below show 4 ring magnets M, N, O and P placed on a wooden stand

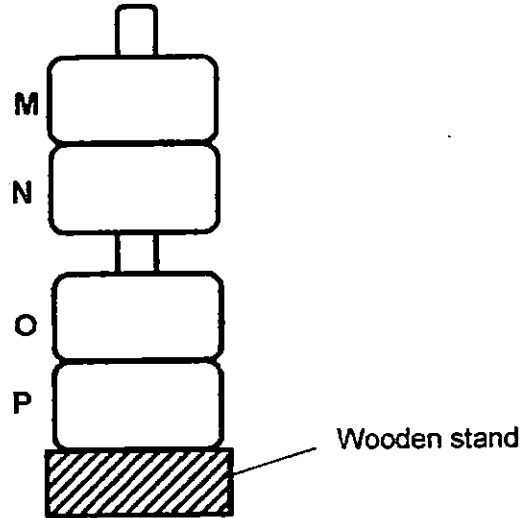

Which of the following shows the correct arrangements of the poles of the magnets?

(1)

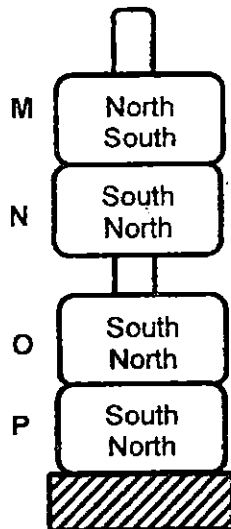

(2)

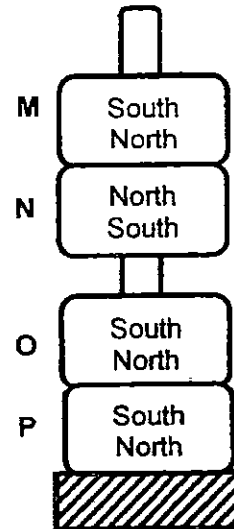

(3)

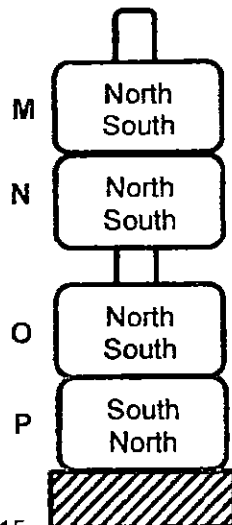

(4)

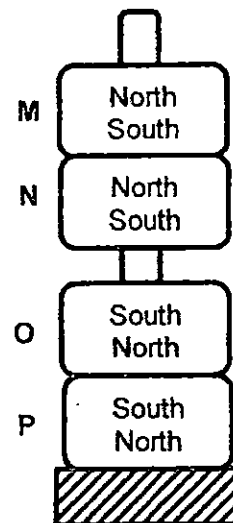

23. Lizzy used a bar magnet to repeatedly stroke a steel bar as shown below.

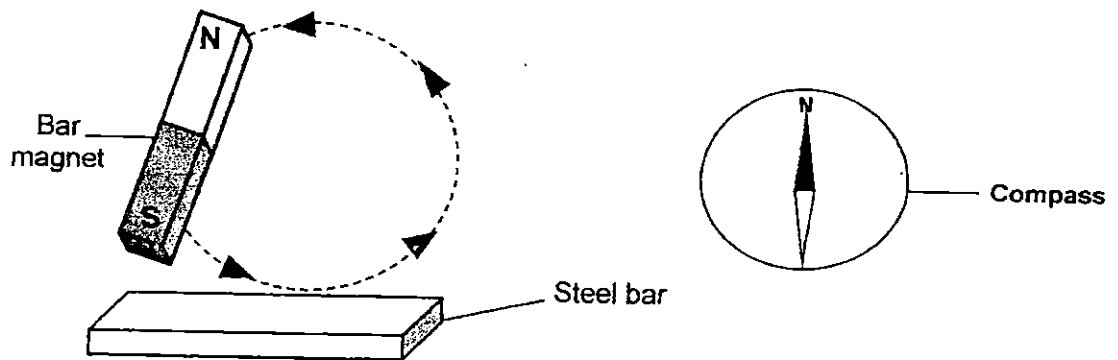

She then placed the steel bar next to a compass. Which of the following arrangement is a possible observation?

Set-up		
A		
B		
C		
D		

- (1) A and D only
 (2) A and B only
 (3) B and C only
 (4) C and D only

24. Dora conducted an experiment to find out if the number of coils around an iron nail affects the strength of the electromagnet. She recorded her results in the table below.

Number of coils	Number of iron paper clips attracted to the electromagnet
3	7
4	10
5	13
6	16

How does the number of coils around the iron nail affect the strength of the electromagnet?

	Number of coils	Strength of the electromagnet
(1)	Increase	Stronger
(2)	Decrease	Stronger
(3)	Increase	Weaker
(4)	Decrease	Remains the same

25. Darryl wanted to find out whether the number of batteries affects the strength of an electromagnet.

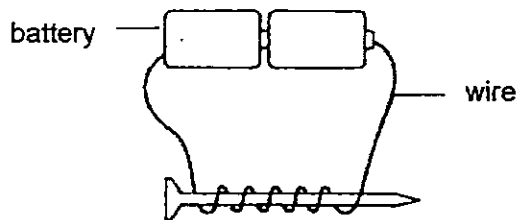

Which of the following variables should he change to ensure a fair experiment?

- (1) Size of the nail
- (2) Size of the batteries
- (3) Number of batteries used
- (4) Number of coils around the nail

End of Booklet A

ANGLO-CHINESE SCHOOL
(JUNIOR)



SEMESTRAL ASSESSMENT 1 (2015)
PRIMARY 4

SCIENCE

BOOKLET B

FRIDAY

8 MAY

1 hour 30 minutes

Name : _____ ()

Class : P4 _____

INSTRUCTIONS TO PUPILS

DO NOT TURN OVER THE PAGES UNTIL YOU ARE TOLD TO DO SO

Follow all instructions carefully.

There are 14 questions in this booklet.

Answer **ALL** questions.

INFORMATION FOR PUPILS

The number of marks is given in brackets [] at the end of each question or part question.

The total marks for this booklet is 40.

The total time for Booklets A and B is 1 hour 30 minutes.

This question paper consists of 17 printed pages (inclusive of cover page).

BOOKLET A	/ 50
BOOKLET B	/ 40
TOTAL	/ 90
Parent's signature/ Date:	

Booklet B (40 marks)

For questions 26 to 39, write your answers in this booklet.

The number of marks available is shown in the brackets [] at the end of each question or part question.

26. Lucas set up an experiment as shown below to find out whether living things need water to survive. He used similar bottles with holes and lizards.

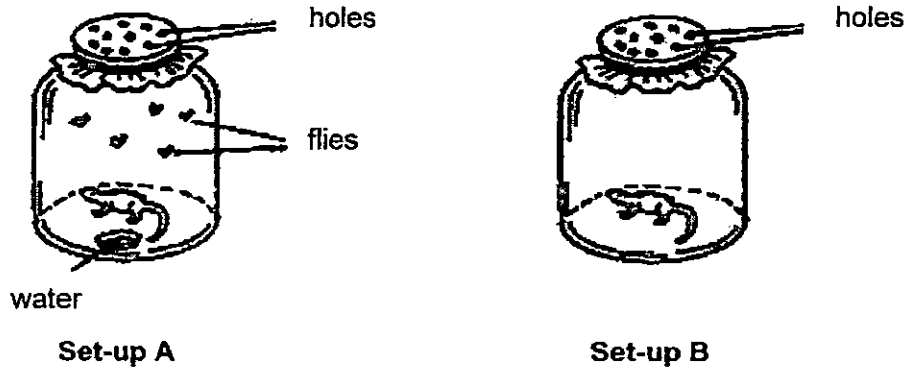

- (a) His father saw the set-ups and said that the experiment was not a fair test. Explain why. [1]

- (b) Predict what would happen to the lizards in set-up A and set-up B after 1 week? [1]

Set-up A: _____

Set-up B: _____

- (c) What should Lucas add to set-up B to make the experiment a fair test? [1]

(Go on to the next page)

SCORE	3
-------	---

27. Sharon placed a slice of fresh bread each into 3 zip-lock bags, A, B and C, and placed each bag at different locations in her house for 2 weeks.

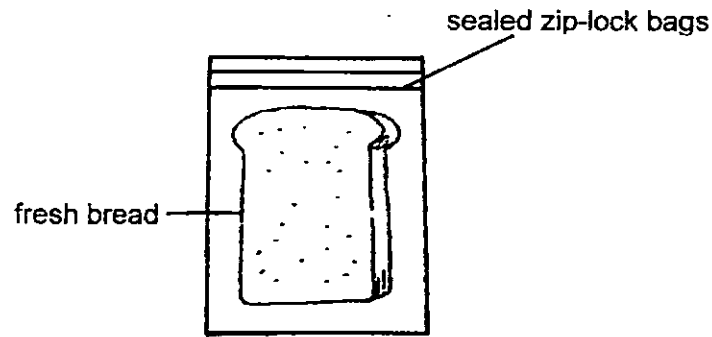

Bag A: Placed at the window sill.

Bag B: Placed in the refrigerator.

Bag C: Placed in the cupboard.

- (a) After 2 weeks, Sharon spotted a type of organism growing on all 3 slices of bread. Name the organism. [1]

- (b) Arrange the bags A, B and C according to the rate at which the organisms would grow on the bread placed in the 3 different locations, starting from the fastest to the slowest. [1]

- (c) What should Sharon do to a new slice of bread if she wants to prevent the organism stated in (a) from growing? [1]

(Go on to the next page)

SCORE	3
-------	---

28. The diagram below shows a bicycle. A bicycle transports a person from one place to another.

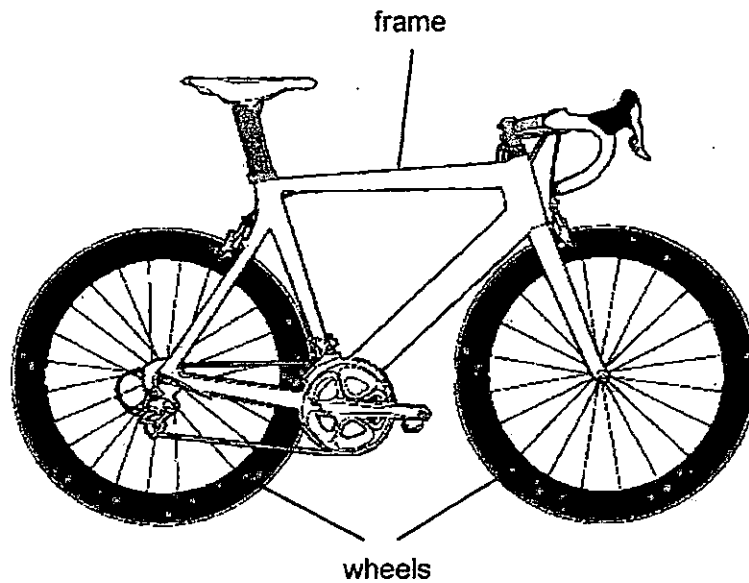

- (a) The bicycle is similar to a human. Name the human system(s) that the bicycle resembles which allows a human to move from one place to another. [1]

- (b) The frame of the bicycle is similar to a human organ/part in terms of its function. Identify the human organ/part and explain how the functions of the frame and the human organ/part that you have identified are similar. [1]

(Go on to the next page)

SCORE	2
-------	---

29. The diagram below shows parts of the digestive system.

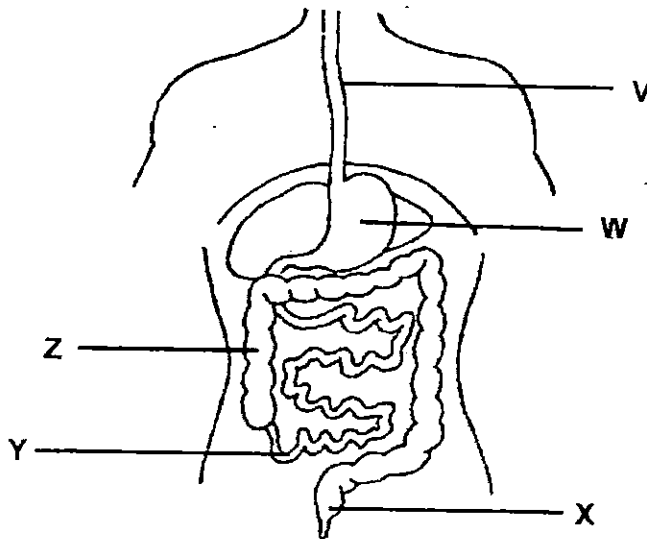

- (a) Based on the diagram above, in which of the 5 labelled parts of the digestive system (V, W, X, Y and Z) is digestive juices produced? [1]

- (b) What is the function of part V? [1]

- (c) Explain what will happen to the undigested food in part Z. [1]

(Go on to the next page)

SCORE	3
-------	---

30. The diagram below shows a flowering plant.

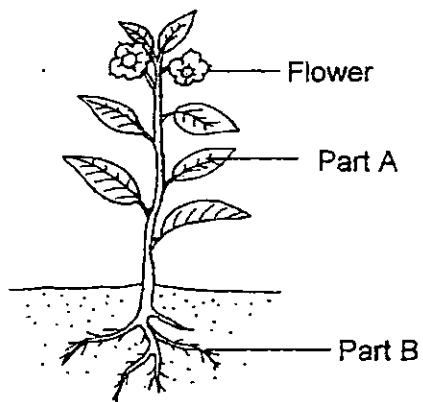

(a) What do the flowers of the plant develop into? [1]

(b) State a function of part A. [1]

(c) State how part B is useful to the plant. [1]

(Go on to the next page)

SCORE	
	3

31. Mei Lee carried out an experiment using the set-ups shown below. She used identical bottles and placed them at the same location. Each bottle was filled with 200 ml of water and fitted with a stopper. Bottles X and Z contain similar plants Q but with different number of leaves.

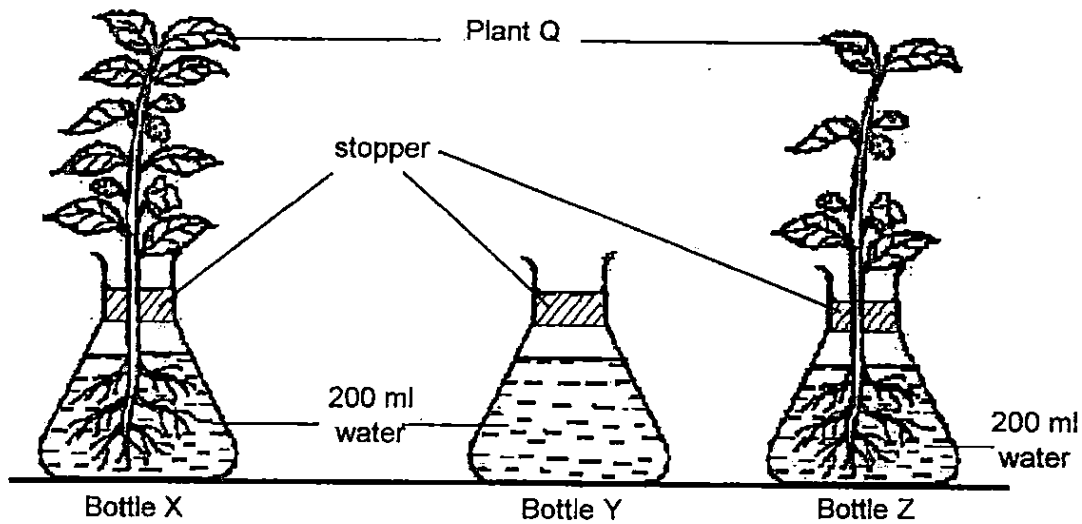

The table below shows the results of the experiment after 3 days.

	Bottle X	Bottle Y	Bottle Z
Number of leaves	9	0	5
Volume of water(ml) left	160	?	185

- (a) What would be the volume of water left in Bottle Y after 3 days? [1]

- (b) Why did the volume of water in Bottles X and Z change over time? [1]

- (c) What is the relationship between the number of leaves and the volume of water left after 3 days? [1]

(Go on to the next page)

SCORE	
	3

32. Study the life cycles of the grasshopper and mealworm beetle shown below.

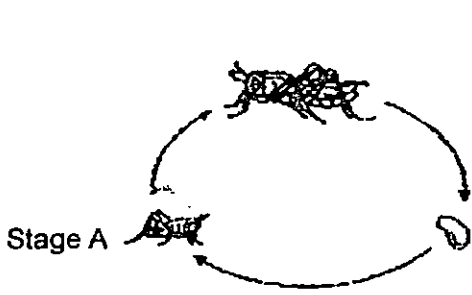

Life cycle of grasshopper

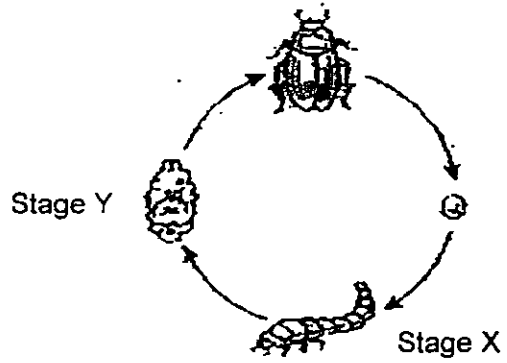

Life cycle of mealworm beetle

(a) State one difference between stage X and Y of the life cycle of the mealworm beetle. (Do not mention shape or size) [1]

(b) State one difference between stage A of the life cycle of the grasshopper and stage X of the life cycle of the mealworm beetle. (Do not mention shape or size) [1]

(Go on to the next page)

SCORE	/
	2

33. Study the classification chart below.

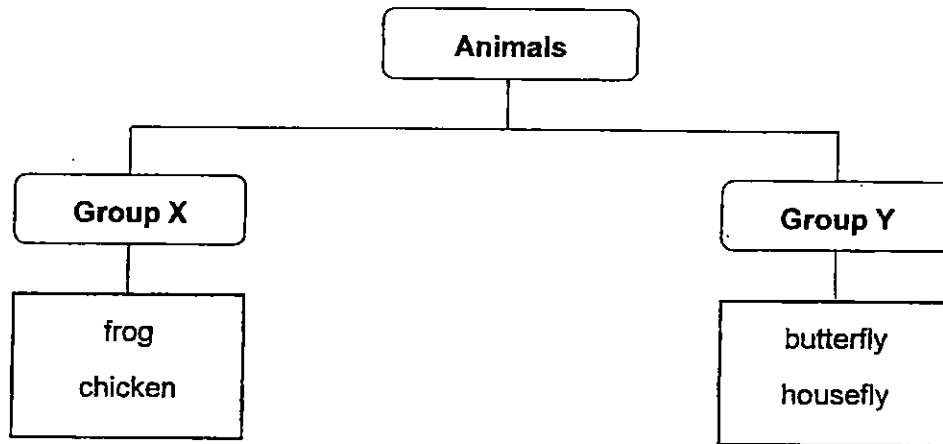

- (a) Suggest an appropriate heading for Group X and Group Y. [1]

Group X : _____

Group Y : _____

Zach found a nymph of an insect and kept it for observation. He noticed that it moulted several times before becoming an adult.

- (b) How many stages are there likely to be in the life cycle of the insect that Zach observed? [1]

- (c) Why did the nymph moult? [1]

(Go on to the next page)

SCORE	3
-------	---

34. Steven observed a seed as it grew into a seedling. He recorded the mass of the seed leaves and shoot of the seedling in the table below.

Results	Day 0	Day 2	Day 4	Day 6	Day 8	Day 10
X	25g	20g	15g	11g	6g	6g
Y	5g	6g	9g	16g	20g	24g

- (a) Which result, X or Y, correctly shows how the mass of the seed leaves change during the period of Steven's observation? Explain your answer. [1]

- (b) After Day 14, the seed leaves dropped off. Explain why. [1]

- (c) State all the conditions needed for a seed to germinate. [1]

(Go on to the next page)

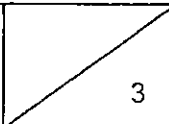
SCORE	
-------	---

35. Mandy carried out an experiment below for her school Science project. She poured 80ml of water into each of the two beakers, X and Y. Then, she placed two similar plants into each beaker, followed by a layer of oil to prevent water from evaporating.

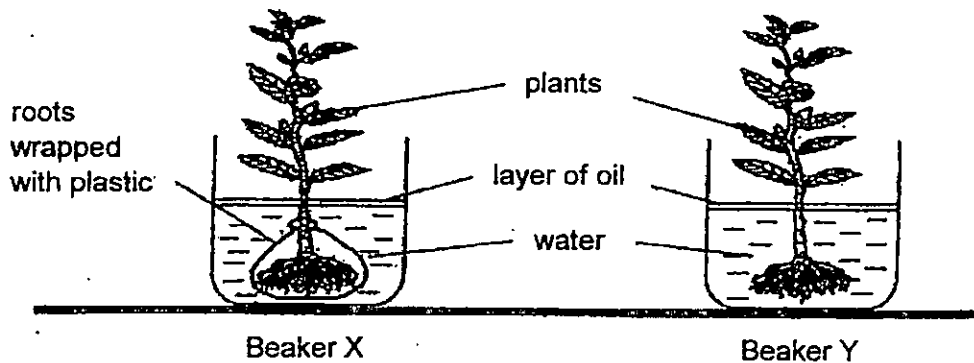

She observed the plants and recorded the amount of water left in the beakers after three days in the table below.

	Volume of water left in beaker (ml)	
	Beaker X	Beaker Y
End of Day 1	80	77
End of Day 2	80	75
End of Day 3	80	70
End of Day 4	80	60

- (a) What is the aim of Mandy's experiment? [1]



- (b) State another variable that she must keep constant to ensure a fair experiment. (Do not repeat those already mentioned) [1]

- (c) How will the results of water left in Beaker Y be affected for the 3 days if Mandy removed most of the leaves from the plant in beaker Y at the start of the experiment? [1]

(Go on to the next page)

SCORE	3
-------	---

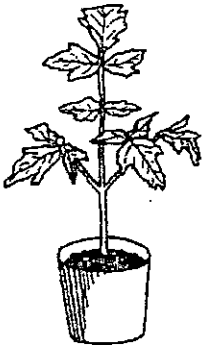
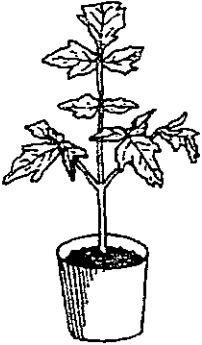
36. Joash wanted to find out how the amount of sunlight a plant received would affect its growth. He put the identical plants at different places as shown in the diagram below.

		
Plant J	Plant K	Plant L
Placed in the school field	Placed in the cupboard	Placed in the living room

After 3 weeks, he observed that all the plants had grown taller. He then recorded the height of the plants.

- (a) Which plant, J, K or L, would most likely have the greatest height? Explain your answer. [1]

- (b) During the 4th week of his experiment, Joash noticed that Plant L was growing towards one direction. Explain why the plant was growing in this way. [1]







- (c) Joash wrote some notes inside his Science textbook about plants. Read the following statements and put a tick (✓) in the true or false column. [1]

	Statements	True	False
(i)	Mosses are not plants		
(ii)	Only flowering plants can bear fruits		
(iii)	Plants need air, water and food to survive		
(iv)	Sunlight is not needed for germination		

(Go on to the next page)

SCORE	3
-------	---

37. Nancy found a box containing six balls of identical size. The balls are made of different materials as stated below.

					
Rubber	Aluminium	Wood	Steel	Plastic	Ceramic

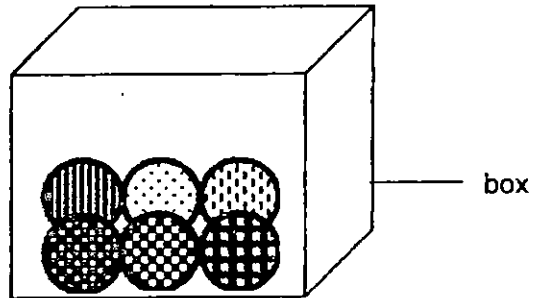

- (a) Nancy found a magnet, cotton wool, a compass and some iron filings on the table. Explain how she may use one or more of these materials to get only the steel ball out from the tank. [1]

- (b) Classify the six balls into two groups with suitable headings. [2]

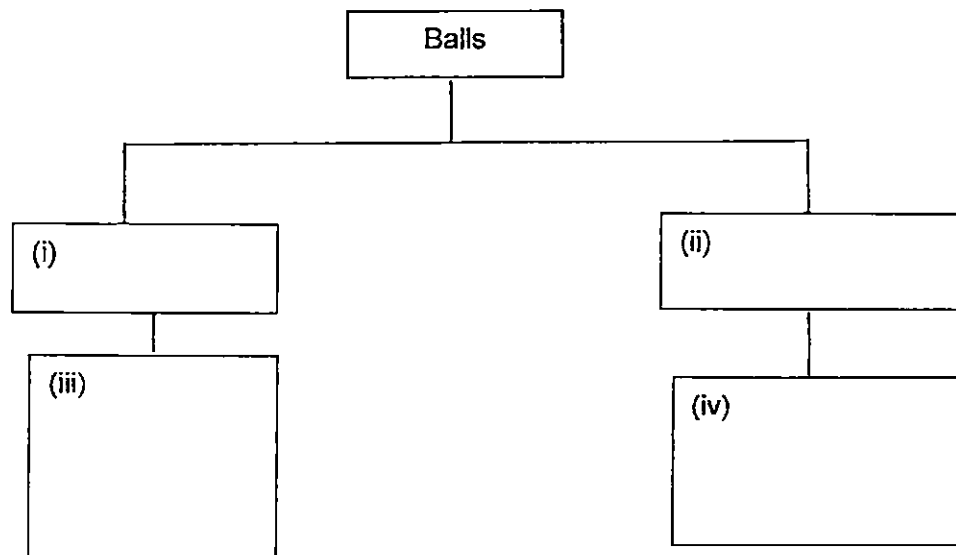

(Go on to the next page)

SCORE	3
-------	---

38. John conducted an experiment using a Copper Rod X as shown in the set-up below. The battery is connected to the wires and is working well.

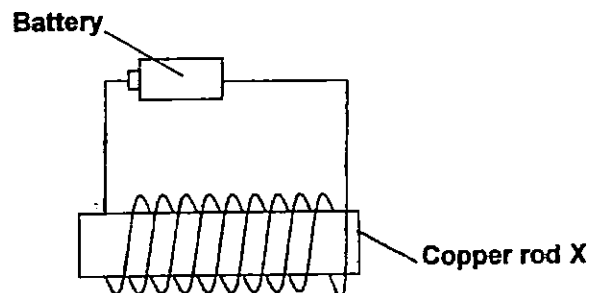

He closed the switch and brought Rod X near some iron paper clips. But none of the paper clips were attracted to it.

- (a) Based on the set-up above, give a reason why the paper clips were not attracted to the Copper Rod X. [1]

- (b) Suggest a change that John can make to the above set-up, in order to make the electromagnet work. [1]

- (c) After John has made the change in (b), suggest 2 other things that he can do to increase the strength of the electromagnet. [1]

(Go on to the next page)

SCORE	3
-------	---

- (d) John brought the new and working magnet near a box of iron nails as shown below.

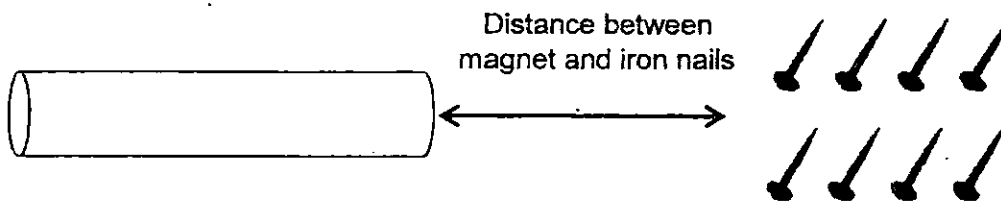

Distance between magnet and the iron nails (cm)	Number of iron nails attracted to the magnet .
5	17
8	9
9	7
12	3

Based on the above table, what is the relationship between the distance between the magnet and the iron nails and the number of iron nails attracted to it? [1]

(Go on to the next page)

SCORE	1
-------	---

39. Rosy pasted a lot of magnets on her fridge as decorations. However, her two-year old son loves to touch them and would accidentally drop them many times on the floor due to his poor grip. After some time, Rosy noticed that some of her fridge magnets kept falling off.

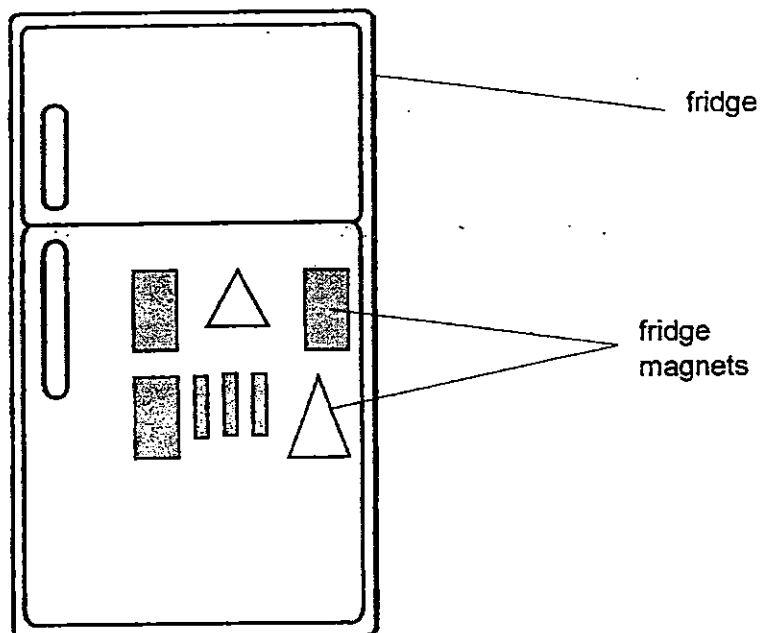

- (a) Explain why the magnets kept falling off the fridge.

[1]

(Go on to the next page)

SCORE	/
	1

The diagram below shows a pair of floating toy wheels which uses the properties of magnetism to work. There are four bar magnets below the toy wheels, labelled M, N, O and P.

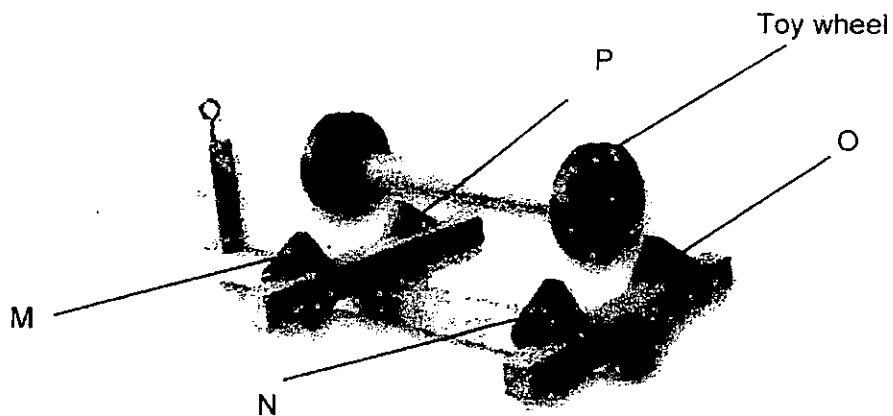

- (b) What is the property of magnets that caused the toy wheels to remain floating above the four bar magnets? [1]

End of Paper

SCORE	1
-------	---



EXAM PAPER 2013

LEVEL : PRIMARY 4

SCHOOL : ANGLO CHINESE SCHOOL (JUNIOR)

SUBJECT : SCIENCE

TERM : SA1

Q 1	Q 2	Q 3	Q 4	Q 5	Q 6	Q 7	Q 8	Q 9	Q 10
3	2	4	1	2	4	1	4	2	3
Q 11	Q 12	Q 13	Q 14	Q 15	Q 16	Q 17	Q 18	Q 19	Q 20
2	4	2	3	1	4	4	4	2	3
Q21	Q22	Q23	Q24	Q25					
1	4	1	1	3					

Q26a. There were no flies in set – up B for the lizard in set up B to eat.

Q26b. Set up A : The lizard would survive.

Q26b. Set up B : The lizard would die.

Q26c. Lucas should add the same number of flies in set up A to set up B.

Q27a. The organism is mould.

Q27b. Bag C, Bag A, Bag B.

Q27c. Sharon should toast the new slice of bread to prevent the organism stated in (a) from growing.

Q28a. The systems are the muscular system and skeletal system.

Q28b. The organ is the spine. The bicycle frame supports the bicycle like how the spine supports the human body.

Q29a. They are W and Y.

Q29b. The function of part V is to push the food to part W.

Q29c. Water will be removed from the undigested food.

Q30a. The flowers will develop into fruits.

Q30b. Part A is used to make food for the plant.

Q30c. Part B is useful to the plant because it helps absorb water and minerals.

Q31a. The volume will remain as 200ml of water.

Q31b. The roots take in water.

Q31c. The relationship is that the more leaves the less water will be left after 3 days.

Q32a. At stage X the mealworm larva eats a lot but at stage Y it does not eat at all.

Q32b. Stage A of the life cycle of a grasshopper, the grasshopper looks like its adult but stage X of the life cycle of a mealworm beetle does not look like the adult.

Q33a. Group X: Has 3 stages in the life cycle.

Q33a. Group Y: Has 4 stages in the life cycle.

Q33b. There should be 3 stages in the life cycle of the insect Zack observed.

Q33c. The nymph molted because its exoskeleton is too small for it.

Q34a. X correctly shows how the seed leaves change during this period. The seed leaves get lighter as its food supply is being used up.

Q34b. After Day 14, the seed leaves have no more food and is not needed anymore.

Q34c. The seed needs water, air and warmth to germinate.

Q35a. Mandy's aim is to see if plants roots absorb water.

Q35b. The same location.

Q35c. The plant will not absorb a lot of water.

Q36a. J. The school field has the most sunlight.

Q36b. It needs to get more sunlight.

Q36c. SEE PICTURE

Q37a. The magnet can attract the steel ball.

	Q36c. Statements	True	False
(i)	Mosses are not plants		✓
(ii)	Only flowering plants can bear fruits	✓	
(iii)	Plants need air, water and food to survive	✓	
(iv)	Sunlight is not needed for germination	✓	

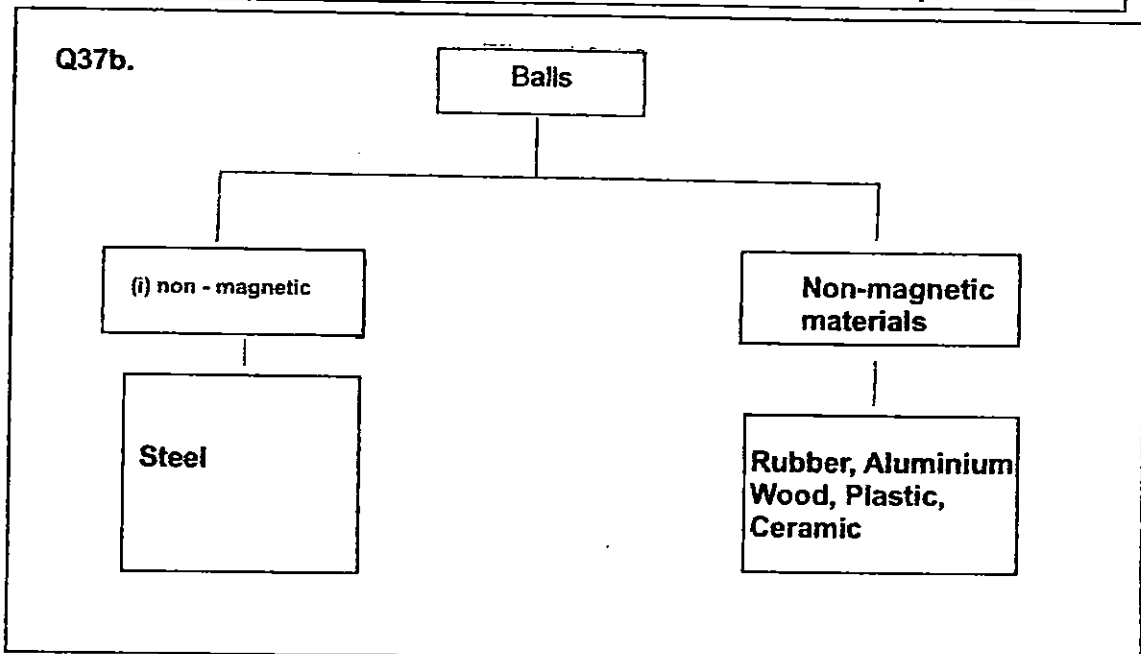

Q38a. Copper is not a magnetic material.

Q38b. Use a magnetic material item to replace rod X.

Q38c. Add the number of coils and batteries.

Q38d. The further the distance between the magnet and iron nails the less iron nails are attracted.

Q39a. When the magnets drop on the floor the magnet will lose its magnetism.

Q39b. Like poles repel, this cause the toy wheel to remain floating in the air.

THE END