

METHODIST GIRLS' SCHOOL
Founded in 1887



MID-YEAR EXAMINATION 2016
PRIMARY 4
SCIENCE

BOOKLET A

Total Time for Booklets A and B: 1 hour 20 minutes

INSTRUCTIONS TO CANDIDATES

Do not turn over this page until you are told to do so.

Follow all instructions carefully.

Answer all questions.

Shade your answers in the Optical Answer Sheet (OAS) provided.

Name: _____ ()

Class: Primary 4. _____

Date : 12 May 2016

This booklet consists of 18 printed pages including this page.

For each question from 1 to 28, four options are given. One of them is the correct answer. Make your choice (1, 2, 3 or 4). Shade the correct oval on the Optical Answer Sheet (OAS).

[56 marks]

1. Which one of the following characteristics shows that a dragonfly is a living thing?
- (1) A dragonfly lays eggs.
 - (2) A dragonfly has wings.
 - (3) A dragonfly is smaller than a book.
 - (4) A dragonfly has a pair of antennae on its head.

2. Study the characteristics of P, Q, R and S in the table shown below.

	Has legs	Needs water	Ability to move from place to place
P	No	Yes	No
Q	Yes	Yes	Yes
R	No	Yes	Yes
S	Yes	No	Yes

Which one of the following is most likely to be a non-living thing?

- (1) P
- (2) Q
- (3) R
- (4) S

(Go on to the next page)

3. Jusri saw a Bird's nest fern on his way home from school as shown below.



Which of the following group(s) can this plant be placed into?

Group A	Group B	Group C
Bears flowers	Reproduces by spores	Makes its own food

- (1) B only
- (2) A and B only
- (3) A and C only
- (4) B and C only

(Go on to the next page)

4. Study the flow chart as shown below.

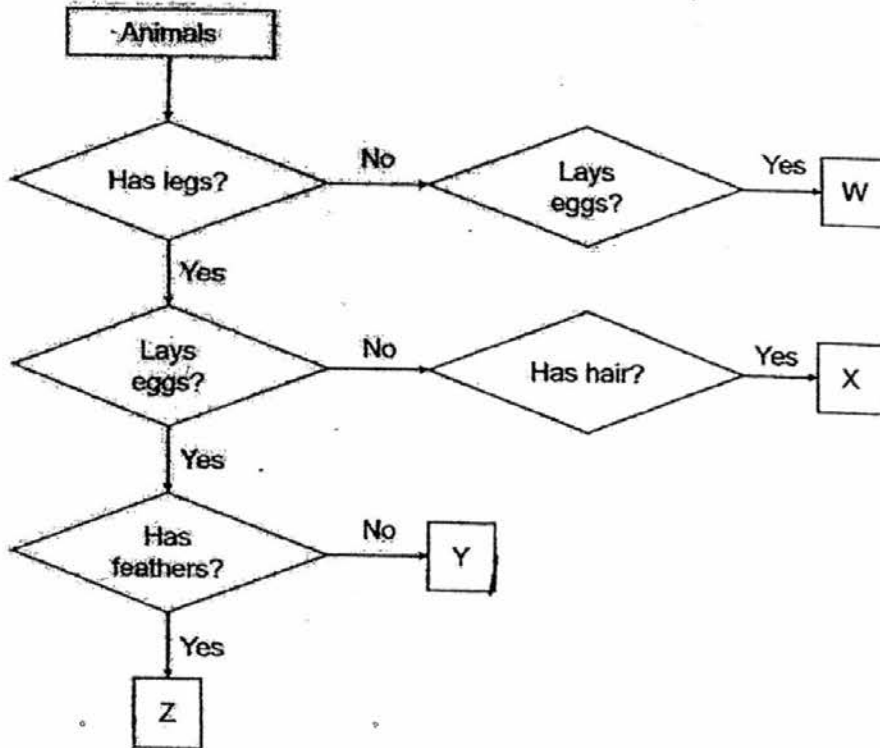

Which animals could W, X, Y and Z be?

	W	X	Y	Z
(1)	snake	penguin	snake	chicken
(2)	goldfish	lion	turtle	sparrow
(3)	whale	snake	chicken	shark
(4)	lion	dolphin	mynah	snake

(Go on to the next page)

5. Shumin placed four similar apples in four identical sealed boxes as shown below.

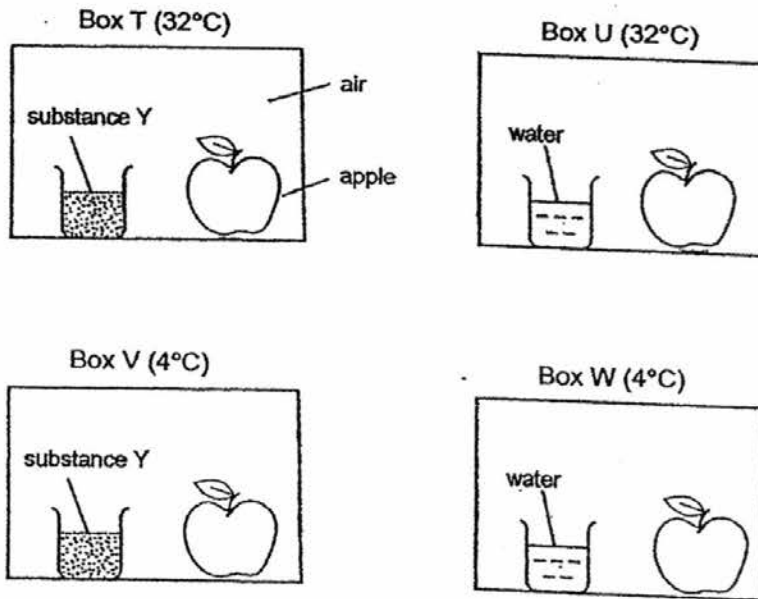

She placed the boxes T and U at 32°C and boxes V and W at 4°C. Substance Y absorbs water from the surrounding. Which box, T, U, V and W, would fungus first appear on the apple?

- (1) Box T
- (2) Box U
- (3) Box V
- (4) Box W

(Go on to the next page)

6. A seed germinated after 5 days and it became a young plant. The young plant was given light, water and air from the 6th - 10th day. Which one of the following graphs shows the changes in the height of the young plant between the 6th - 10th day?

(1)

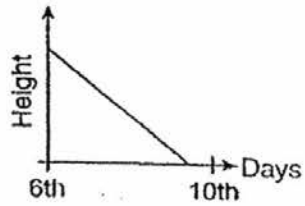

(2)

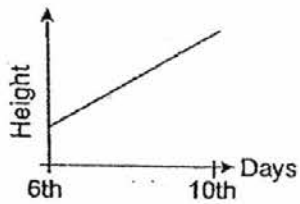

(3)

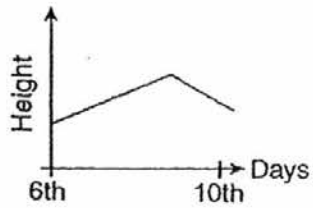

(4)

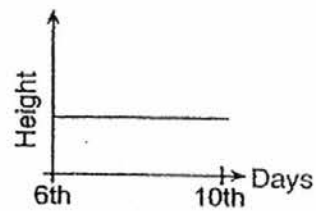

(Go on to the next page)

7. Study the life cycle of an insect below.

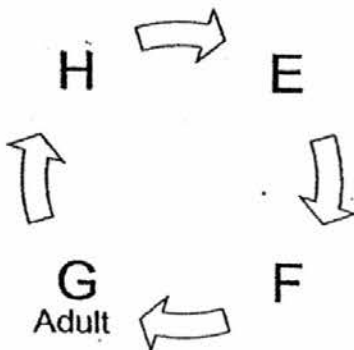

If G represents the adult stage, at which stage does the process of moulting take place?

- (1) E
 - (2) F
 - (3) G
 - (4) H
8. Mary did a study on two animals, Q and R. At the end of her study, she completed a checklist as shown below.

Observation	Animal Q	Animal R
It has six legs.	√	√
Eggs are laid in water.	X	√
There are 4 stages in the life cycle.	X	√

Which one of the following shows Animal Q and R correctly?

	Animal Q	Animal R
(1)	Butterfly	Beetle
(2)	Grasshopper	Butterfly
(3)	Mosquito	Frog
(4)	Cockroach	Mosquito

(Go on to the next page)

9. The diagram below shows a part of a leaf under a microscope.

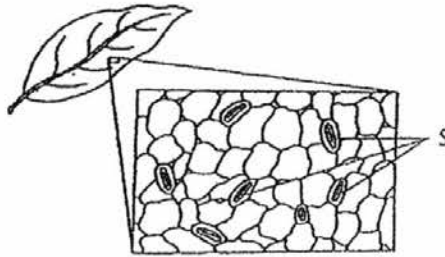

What is the function of the leaf that are labelled S?

- (1) They make food for the plant.
 (2) They absorb water for the plant.
 (3) They take in light only for the plant.
 (4) They allow gaseous exchange for the plant.
10. The diagram below shows a healthy plant in a garden.

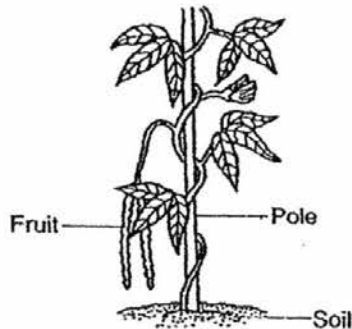

Which of the following statement(s) is/are correct?

A	This plant has a weak stem.
B	This plant is a flowering plant.
C	This plant does not have roots.

- (1) A only
 (2) A and B only
 (3) A and C only
 (4) A, B and C

(Go on to the next page)

11. Study the statements made by the three students carefully.

Student	Function
Fatimah	The leaves make food for the plant.
Jie Ming	The stem supports the branches and leaves of the plant.
Donna	The roots transport water and mineral salts throughout the plant.

Which student(s) has/have made the wrong statement about the function of a plant part?

- (1) Donna
 - (2) Jie Ming
 - (3) Fatimah and Jie Ming
 - (4) Donna and Jie Ming
12. Kumar wanted to find out if the seeds of different plants germinate at the same time. He made sure that the conditions for growth were provided for the seeds to germinate well. What other variables should also be considered to make his experiment a fair one?

T : The type of seeds.
U : The size of the pots.
V : The amount of soil used in each pot.

- (1) U only
- (2) T and U only
- (3) T and V only
- (4) U and V only

(Go on to the next page)

13. Study the classification chart below.

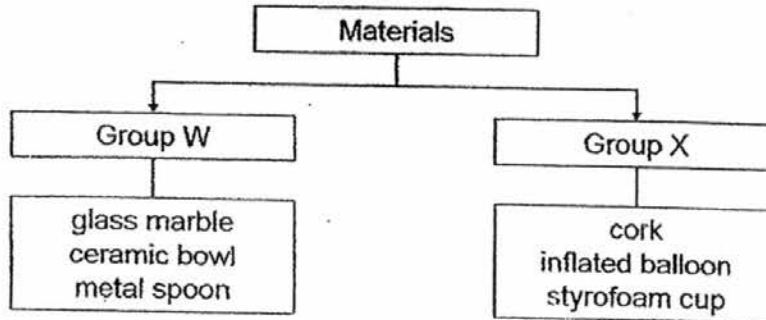

Which one of the following headings is correct for Group W and X?

	Group W	Group X
(1)	Stiff	Flexible
(2)	Natural	Man-made
(3)	Sinks in water	Floats on water
(4)	Light can pass through	Light cannot pass through

14. Bala placed four equal lengths of different fabrics, M, N, O and P into a dish containing some coloured water. Fifteen minutes later, he observed that fabric M, N, O and P absorbed the water from the dish. The shaded portion of the fabrics shows the amount of water absorbed by the materials.

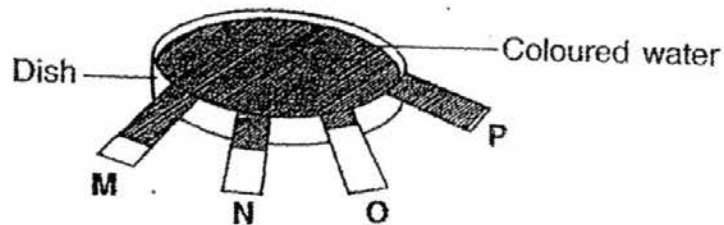

Which one of the following conclusions about fabrics M, N, O and P is correct?

	Least absorbent		Most absorbent	
(1)	P	M	N	O
(2)	M	N	O	P
(3)	O	N	M	P
(4)	N	M	P	O

(Go on to the next page)

15. Some properties of four materials, A, B, C and D were tested in a laboratory. The results are shown below.

Material	Brittle	Stiff	Waterproof
A	X	√	√
B	X	X	X
C	X	X	√
D	√	√	√

Which one of the material above represents a rubber band?

- (1) A
 (2) B
 (3) C
 (4) D
16. Four parts of a bar magnet are labelled H, I, J and K as shown in the diagram below.

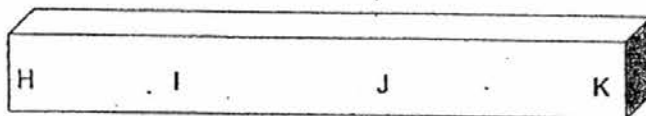

Which of the following represents the number of nails that are attracted to parts H, I, J and K of a bar magnet?

	Part H	Part I	Part J	Part K
(1)	2	3	5	7
(2)	9	1	2	11
(3)	7	5	4	2
(4)	2	11	11	4

(Go on to the next page)

17. Prema strung three ring magnets through a pencil and she pushed it together by hand. When the grip was released, the following was observed.

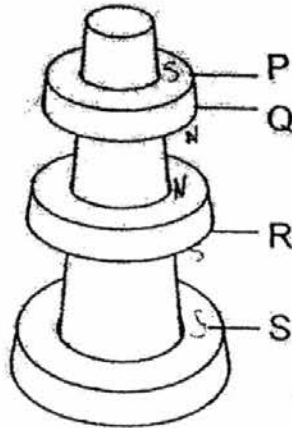

Which one of the following correctly shows the poles of P, Q and R?

	P	Q	R	S
(1)	South	South	South	North
(2)	South	North	South	South
(3)	North	North	South	South
(4)	North	South	South	North

(Go on to the next page)

18. Tian Le wanted to find out if the number of turns of the wire around the iron nail would affect the magnetic strength of an electromagnet. Which two arrangements below should he choose in order to conduct a fair test?

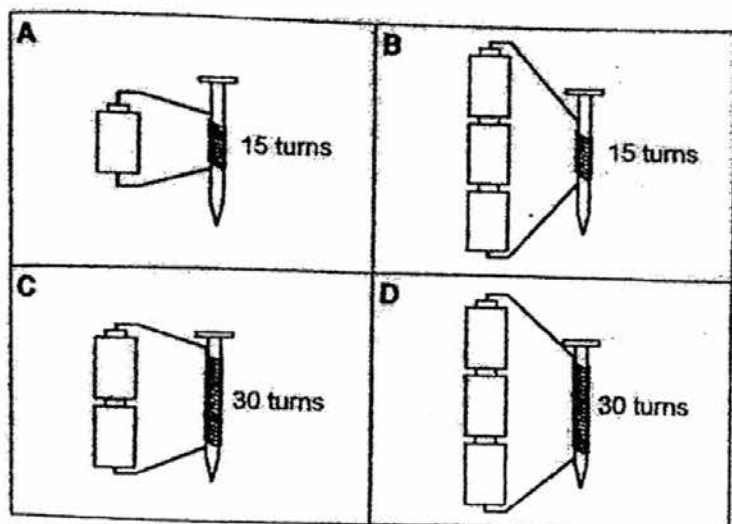

- (1) A and B only
 (2) B and C only
 (3) B and D only
 (4) C and D only
19. The following describes a substance in different states of matter.

State Q
No definite shape Can be compressed

State R
Definite shape Cannot be compressed

Which one of the following correctly identifies the substance in State Q and State R?

	State Q	State R
(1)	Solid	Liquid
(2)	Liquid	Gas
(3)	Gas	Liquid
(4)	Gas	Solid

(Go on to the next page)

20. Farah had 40 ml of water in a measuring cylinder. She then placed four objects, A, B, C, D, one at a time, into the measuring cylinder. Each time she placed an object into the measuring cylinder, she recorded the total volume. The graph below shows the total volume after each object has been placed into the measuring cylinder.

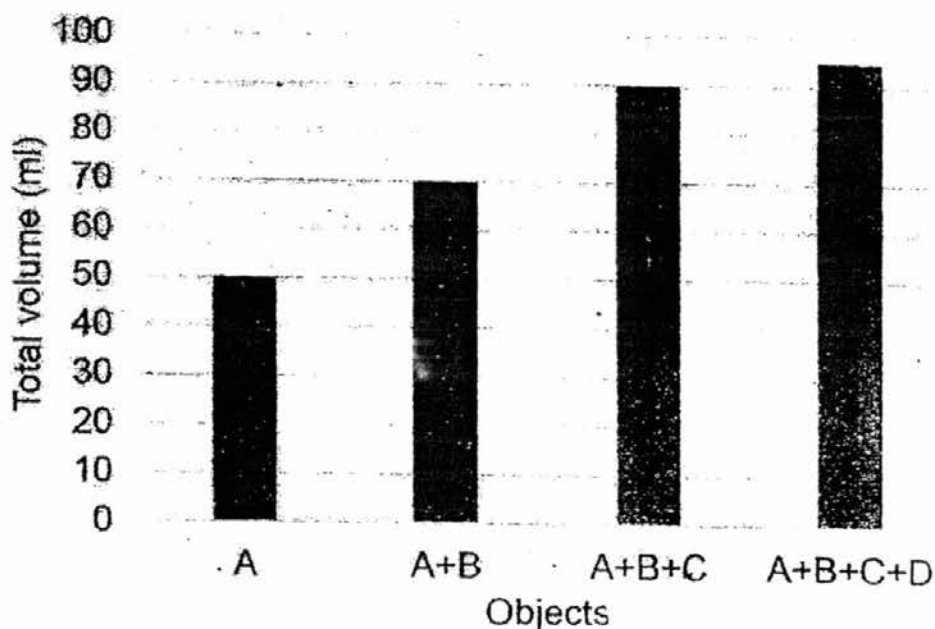

Study the statements below carefully.

- R: Object D has a smaller volume than B.
 S: Object B and C have the same amount of matter.
 T: The volume of Object A is twice the amount of Object D.
 U: The amount of water in the measuring cylinder increases after each object is placed into it.

Which of the following statement(s) is/are correct?

- (1) R and T only
- (2) S and U only
- (3) S, T and U only
- (4) All of the above

(Go on to the next page)

21. A sealed container which holds 120 cm^3 of water and 80 cm^3 of air was set up as shown below.

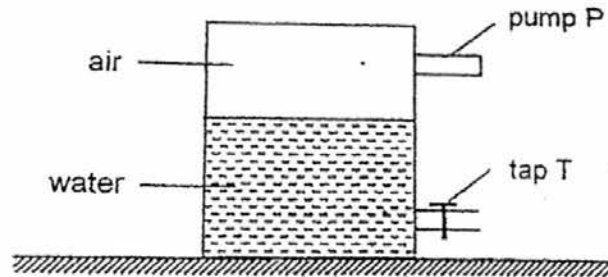

20 cm^3 of water was removed from the container through tap T and 60 cm^3 of air was then pumped into the container using pump P.
What would be the final volume of air in the container?

- (1) 80 cm^3
 (2) 100 cm^3
 (3) 140 cm^3
 (4) 160 cm^3
22. Austen lowered a bottle with the bottom cut off into a trough of water.

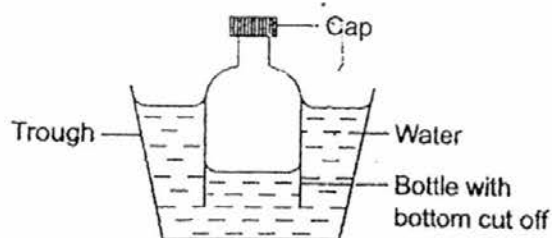

What will happen when Austen removes the cap from the bottle?

- E : The water level in the bottle will increase.
 F : The water level in the bottle will decrease.
 G : Air in the bottle will escape from the bottle.
- (1) E only
 (2) F only
 (3) E and G only
 (4) F and G only

(Go on to the next page)

23. Four sheets of metal were heated to the temperatures indicated in the diagrams below.



Sheet A: 80°C

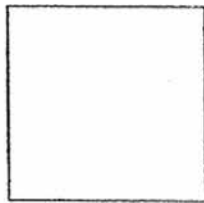

Sheet B: 65°C

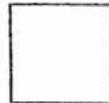

Sheet C: 80°C

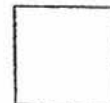

Sheet D: 65°C

Which of the following metal sheets contains the most heat energy?

- (1) Sheet A
 - (2) Sheet B
 - (3) Sheet C
 - (4) Sheet D
24. An experiment was set up as shown below.

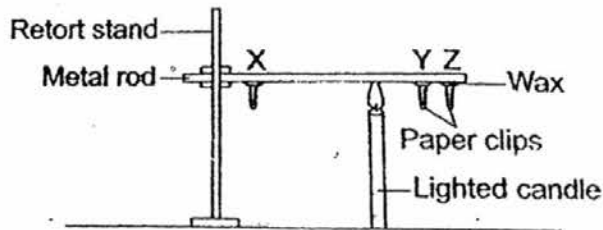

After a few minutes, the paper clips started to drop off the metal rod, one after another. Which one of the following correctly shows the order in which the paper clips will drop off the metal rod?

	First	Second	Third
(1)	X	Y	Z
(2)	X	Z	Y
(3)	Y	Z	X
(4)	Z	Y	X

(Go on to the next page)

25. Georgia wanted to prepare some instant noodles for lunch. When the water started to boil, she added the packet of noodles into the pot of water. The pot of water stops boiling immediately.

Which of the following statements are true?

- J: The packet of noodles is cooler than the water.
 K: The heat transfers from the water to the noodles.
 L: The noodles increase the temperature of the water

- (1) J and K only
 (2) K and L only
 (3) J and L only
 (4) All of the above

26. Collin held a lighted candle over a trough of water as shown below.

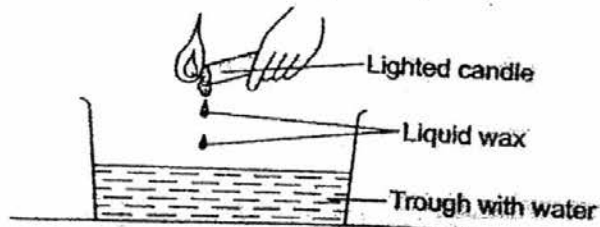

As the liquid wax dripped into the trough of water, solid wax was formed on the surface of the water.

Which of the following statements is/are true?

- Q: The solid wax lost heat to the flame to become liquid wax.
 R: The liquid wax lost heat to the water as it touched the water.
 S: The liquid wax gained heat from the water as it touched the water.

- (1) Q only
 (2) R only
 (3) Q and R only
 (4) Q and S only

(Go on to the next page)

27. Study the set-ups below.

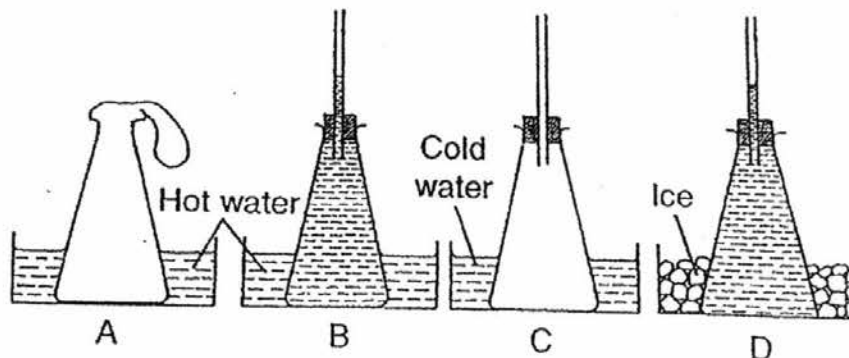

Which of the two set-ups can be used to show the expansion and contraction of a liquid?

- (1) A and B
- (2) B and C
- (3) B and D
- (4) A and C

28. Boiling water was poured into four bottles, P, Q, R and S which are made of different materials. The time taken for the water in each bottle to reach room temperature was recorded as shown below.

Bottle	Time taken for water to reach room temperature
P	13 min
Q	10 min
R	28 min
S	18 min

Which bottle is made of a material that is the poorest conductor of heat?

- (1) P
- (2) Q
- (3) R
- (4) S

METHODIST GIRLS' SCHOOL

Founded in 1887



MID-YEAR EXAMINATION 2016
PRIMARY 4
SCIENCE

BOOKLET B1

Total Time for Booklets A and B: 1 hour 20 minutes

INSTRUCTIONS TO CANDIDATES

Do not turn over this page until you are told to do so.

Follow all instructions carefully.

Answer all questions.

Name: _____ ()

Class: Primary 4. _____

Date : 12 May 2016

Booklet A	56
Booklet B1	16
Booklet B2	18
Total	90
Parent's Signature	

This booklet consists of 7 printed pages including this page.

For questions 29 to 34, write your answers in the spaces provided. The number of marks available is shown in brackets [] at the end of each question or part question.

[16 marks]

29. Meifang observed an animal in her garden as shown below.



woodlouse

She said that it belongs to the animal group, insects. Give two reasons why she is wrong. [2]

Reason 1:

Reason 2:

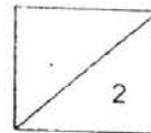

(Go on to the next page)

30. Study the classification chart below.

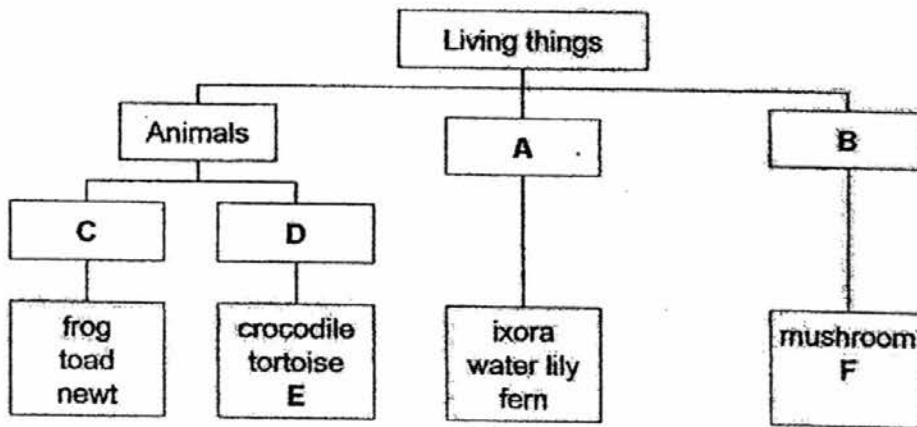

(a) Identify the groups of living things for A and B. [1]

A: _____

B: _____

(b) Identify the animal groups for C and D. [1]

C: _____

D: _____

(c) Give an example of an organism for E and F. [1]

E: _____

F: _____

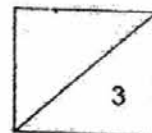

(Go on to the next page)

31. Fairoz set up an experiment in the classroom as shown below.

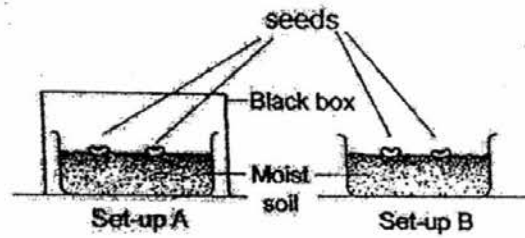

(a) What was Fairoz trying to find out in this experiment? [1]

(b) After 3 days, he noticed that both seeds in set-up A and B germinated. What are the conditions required by the seeds to germinate? [1]

After 3 days, he observed and drew a picture of the germinated seed as shown below.

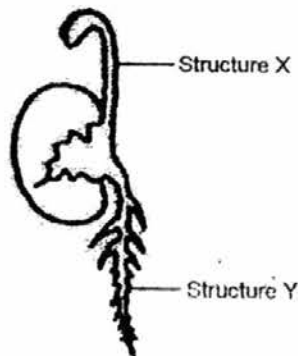

(c) Which structure, X or Y, developed first? [1/2]

(d) Identify structure X. [1/2]

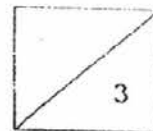

(Go on to the next page)

32. Study the life cycle of the butterfly as shown below.

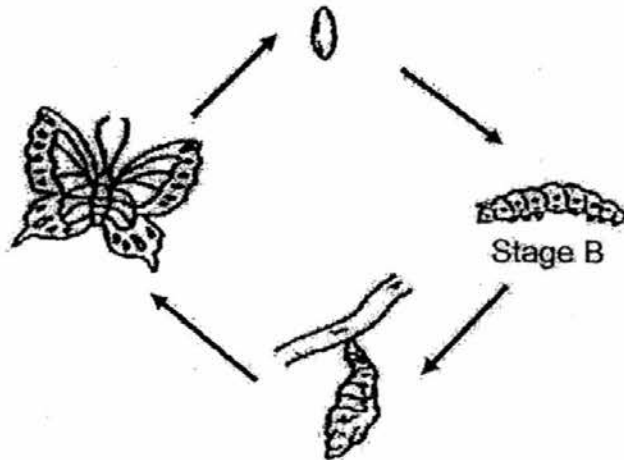

(a) Identify Stage B in the life cycle of the butterfly. [1]

(b) The butterfly does not feed at some stages of its life cycle. Identify the two stages. [1]

(c) Which animal has the same number of stages as the life cycle of the butterfly? [1]

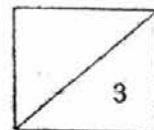

(Go on to the next page)

33. The diagram below shows part of a plant.

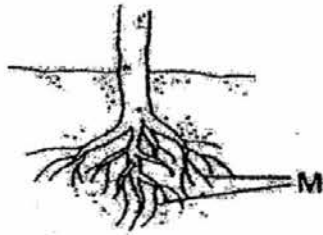

(a) Name the part labelled M. [1]

(b) What are the two functions of part M? [2]

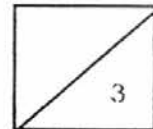

(Go on to the next page)

34. De Ming left a wooden box outside his garden as shown below.

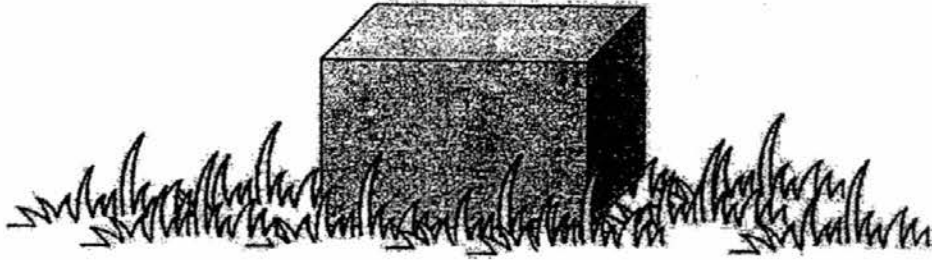

- (a) What would De Ming observe about the grass patch after he lifted up the box a few days later? [1]

- (b) Explain your answer in (a). [1]

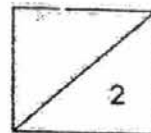

(Go on to the next page)

METHODIST GIRLS' SCHOOL

Founded in 1887



MID-YEAR EXAMINATION 2016
PRIMARY 4
SCIENCE

BOOKLET B2

Total Time for Booklets A and B: 1 hour 20 minutes

INSTRUCTIONS TO CANDIDATES

Do not turn over this page until you are told to do so.

Follow all instructions carefully.

Answer all questions.

Shade your answers in the Optical Answer Sheet (OAS) provided.

Name: _____ ()

Class: Primary 4. _____

Date : 12 May 2016

Booklet B2	18
------------	----

This booklet consists of 7 printed pages including this page.

For questions 35 to 40, write your answers in the spaces provided. The number of marks available is shown in brackets [] at the end of each question or part question.

[18 marks]

35. Devi set up an experiment as shown below.

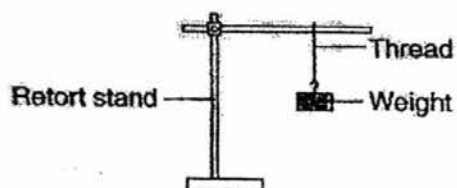

She added weights to the thread until it broke. She repeated the experiment using threads of four different materials and recorded the results in the table shown below.

Thread	W	X	Y	Z
Number of weights before the thread broke	12	5	2	8

- (a) What property of the materials was Devi trying to find out from this experiment?

[1]

Devi wanted to make a lantern as shown below.

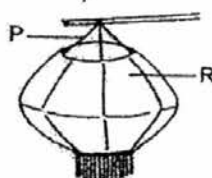

- (b) Which thread should Devi choose for part P so that the lantern would be durable? Give a reason for your answer.

[1]

- (c) Devi placed a lighted candle in the lantern. What property should part R have in order for the lantern to be useful at night?

[1]

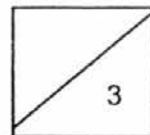

(Go on to the next page)

36. Lu Kai set up an experiment as shown below.

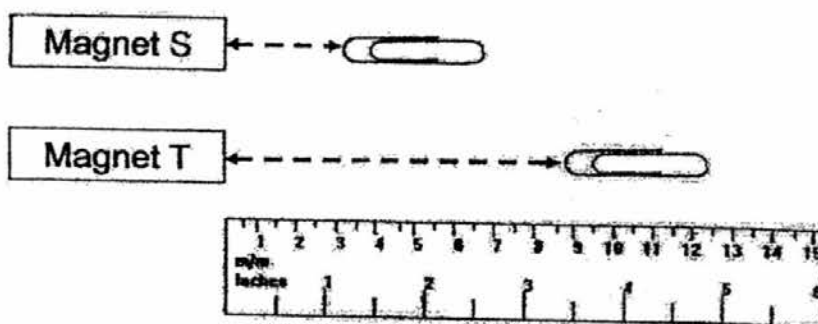

He slowly pushed the paper clips towards the magnets along the ruler. He then measured the distance at which the paper clips are attracted to the magnets. The results are shown below.

Magnet	Distance at which the paper clip is attracted to the magnet
S	3 cm
T	9 cm

- (a) Which magnet has a stronger magnetic strength? Explain your answer. [2]

- (b) What material could the paper clip be? [1]

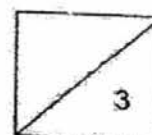

(Go on to the next page)

37. Juliana set up an experiment as shown below.

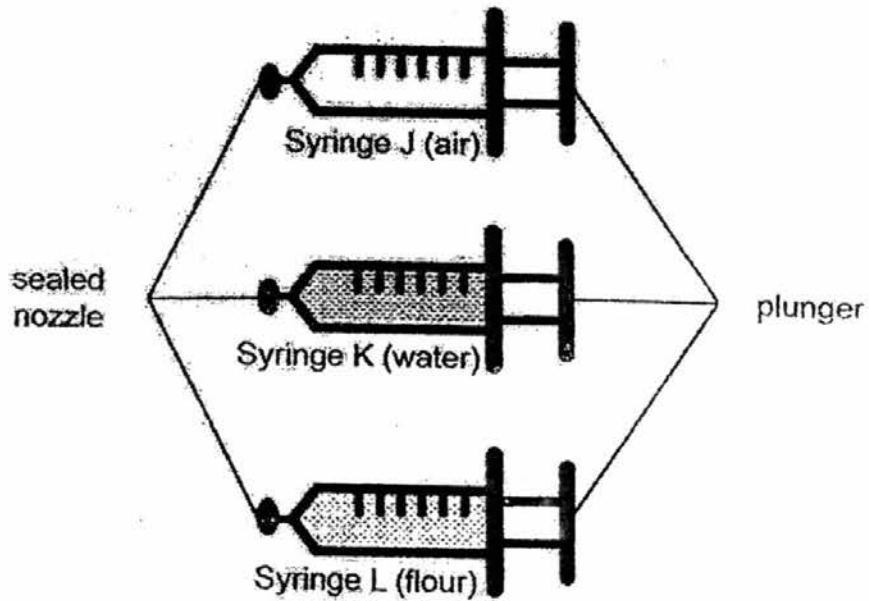

She used three identical syringes and put in equal volumes of air, water and flour in each of the syringe. She then pushed the plunger of each syringe using the same strength.

- (a) What would Juliana's observation be for Syringe J, K and L after she pushed the plunger of each syringe? [1]

- (b) Was the experiment a fair test? Explain why. [2]

- (c) What could Juliana conclude from this experiment about the three states of matter? [1]

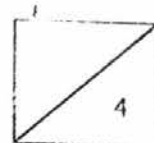

(Go on to the next page)

38. Clement blew equal amount of air into balloons X and Y as shown below.

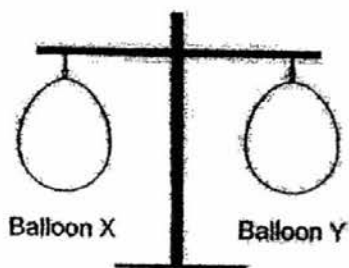

He then pricks Balloon Y with a needle.

- (a) Draw his observation and label the balloons after he has pricked Balloon Y in the box below. [1]

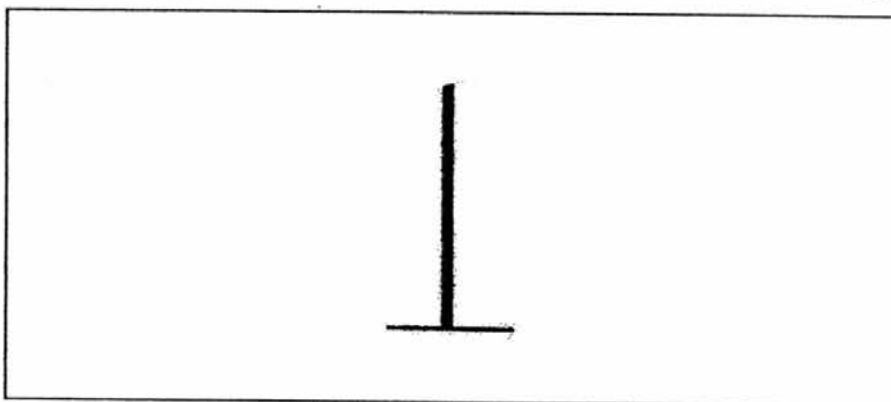

- (b) What does Clement's experiment show? [1]
-

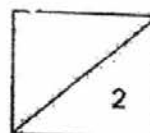

(Go on to the next page)

39. Mirah set up the experiment as shown below.

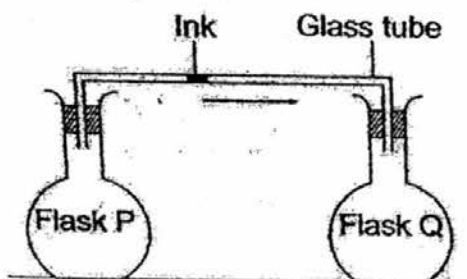

Flask P and Q contain air and there is a drop of ink in the glass tube. She wanted to move the ink in the glass tube. Her teacher suggested that she could do that by placing either one of the flasks in a basin of hot water.

- (a) Which flask should Mirah choose to put into the basin of hot water if she wants the drop of ink to move towards Flask Q? [1]

- (b) Explain how the hot water in the basin caused the ink in the glass tube to move? [2]

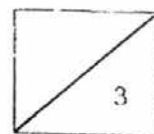

(Go on to the next page)

40. Xinhui set up an experiment as shown below.

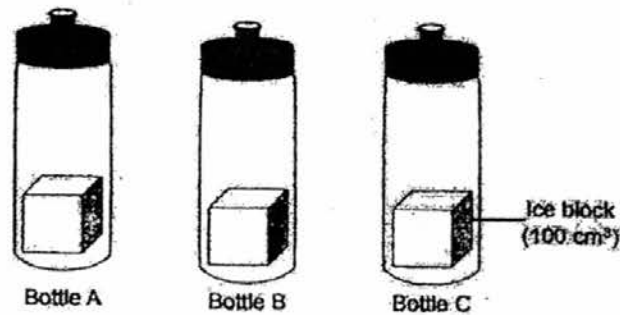

She placed an ice block of equal volume in each bottle made of different materials. 30 minutes later, she removed the ice block and measured the amount of water collected in each bottle and recorded her findings in the graph below.

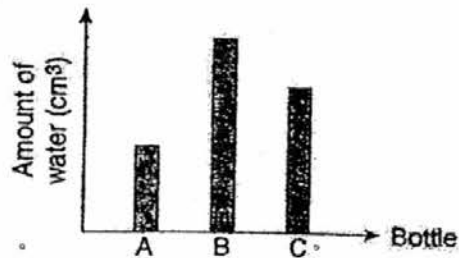

- (a) If you are going to the beach on a hot day, which bottle would you choose to keep your drink cold? [1]

- (b) Explain why you chose the bottle in (a). [2]

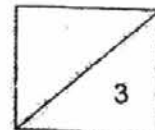

YEAR : 2016
LEVEL : PRIMARY 4
SCHOOL : METHODIST GIRLS'
SUBJECT : SCIENCE
TERM : SA1

Booklet A

Q1	1	Q5	2	Q9	4	Q13	3	Q17	2	Q21	2	Q25	1
Q2	4	Q6	2	Q10	2	Q14	3	Q18	3	Q22	3	Q26	2
Q3	4	Q7	1	Q11	1	Q15	3	Q19	4	Q23	1	Q27	3
Q4	2	Q8	4	Q12	4	Q16	2	Q20	1	Q24	3	Q28	3

Booklet B1

Q29 Reason 1: Insects have six legs but the woodlouse does not.
Reason 2: Insects have 3 body parts but the woodlouse does not.

Q30a A: Plants
B: Fungi

Q30b C: Amphibians
D: Reptiles

Q30c E: Snake / Lizard
F: Bread mould

Q31a Whether seeds need light to germinate.

Q31b Air, water and warmth.

Q31c Structure Y.

Q31d The shoot.

Q32a The larva stage.

Q32b The egg and pupa stages.

Q32c The mosquito.

Q33a The root.

Q33b The first function is to anchor the plant firmly into the soil. The second function is to absorb minerals and water from the soil.

- Q34a** The grass patch would have turned brown.
- Q34b** There is no light under the box so the grass is unable to make food.

Booklet B2

- Q35a** Devi was trying to find out how strong each material was.
- Q35b** She should use material W because it is the strongest.
- Q35c** The material should be transparent.
- Q36a** Magnet T as it could attract the paper clips from a further distance than Magnet S.
- Q36b** The paper clip could be iron or steel.
- Q37a** Only syringe J would be able to be pushed in.
- Q37b** Yes, all the variables were kept the same except for one variable which is the substance in the syringe.
- Q37c** Only gas can be compressed.
- Q38a**

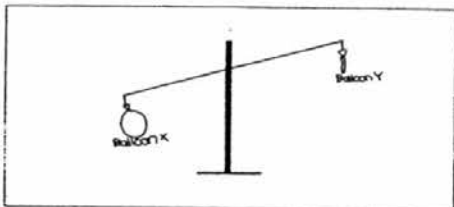

- Q38b** Air has mass.
- Q39a** She should put flask P in the basin of hot water.
- Q39b** The hot water will cause the air in flask P to gain heat expand, pushing the ink drop towards flask Q.
- Q40a** Bottle A.
- Q40b** The ice in bottle A melted the slowest so the material of the bottle must be a poor conductor of heat.

End