



HENRY PARK PRIMARY SCHOOL

SEMESTRAL EXAMINATION 2

2007

SCIENCE

PRIMARY 4

BOOKLET A

Name: _____ ()

Class: Primary 4 _____

30 Questions
60 Marks

Total Time for Booklets A and B: 1 h 30 min

DO NOT OPEN THIS BOOKLET UNTIL YOU ARE TOLD TO DO SO.

READ AND FOLLOW INSTRUCTIONS CAREFULLY.

PART 1 (60 marks)

For each question from 1 to 30, four options are given. One of them is the correct answer. Make your choice (1, 2, 3 or 4). Shade the correct oval (1, 2, 3 or 4) on the Optical Answer Sheet.

1. A syringe is filled with water. When its plunger is pushed, a jet of water shoots out in the direction as shown below.

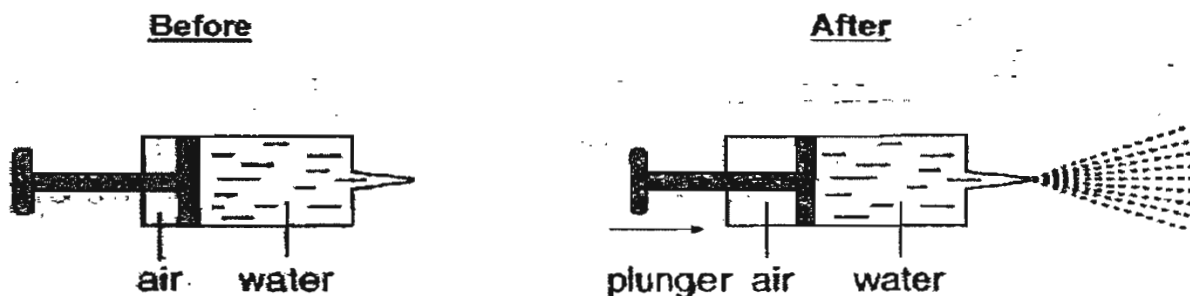

What has happened to the water and the air in the syringe?

- A. The volume of water has increased.
- B. The volume of water has decreased.
- C. The volume of air remained the same.
- D. The volume of air increased.

- (1) A and D only
- (2) B only
- (3) B and C only
- (4) B and D only

2. The table shows the result of an experiment on three substances A, B, C.

Properties	A	B	C
definite shape	Yes	No	No
has definite mass	Yes	Yes	Yes
definite volume	Yes	No	Yes

Which of the following identifies these substances correctly?

- (1) A – solid, B – liquid, C – gas
- (2) A – liquid, B – solid, C – gas
- (3) A – gas, B – solid, C – liquid
- (4) A – solid, B – gas, C – liquid

3. A beaker of water was placed in the fridge. The diagram below shows the beaker of water when it was just taken out of the fridge.

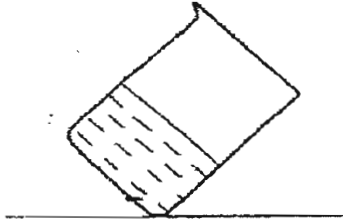

At the beginning

Which one of the following diagrams shows what has taken place after two hours?

(1)

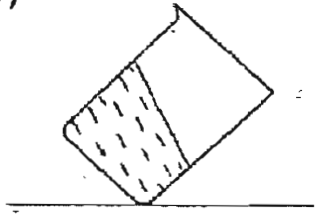

(2)

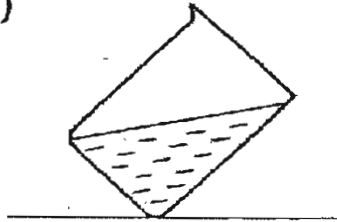

(3)

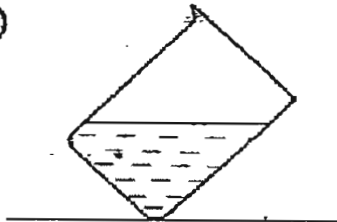

(4)

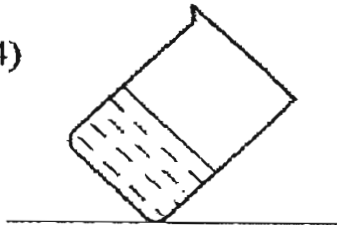

4. The diagram shows how water moves from the Earth's surface to the air and back again.

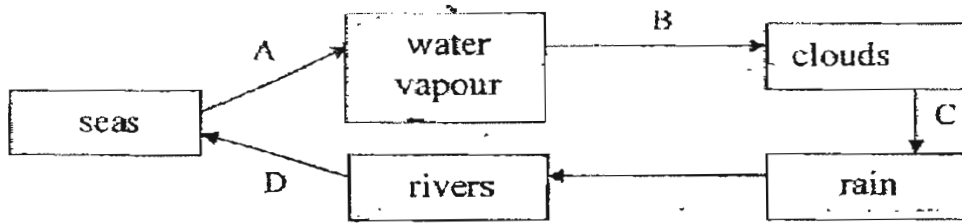

The process of evaporation takes place at _____.

- (1) A
 - (2) B
 - (3) C
 - (4) D
5. Which of the following action(s) is/are most likely to pollute the Earth's water resources?
- A. Taking long showers.
 - B. Spraying insecticides and pesticides near rivers and lakes
 - C. Burning of rubbish
 - D. Throwing harmful waste into the sea
- (1) A and B only
 - (2) B and D only
 - (3) B, C and D only
 - (4) All of the above

6. Which diagram shows how breathing takes place in a fish?

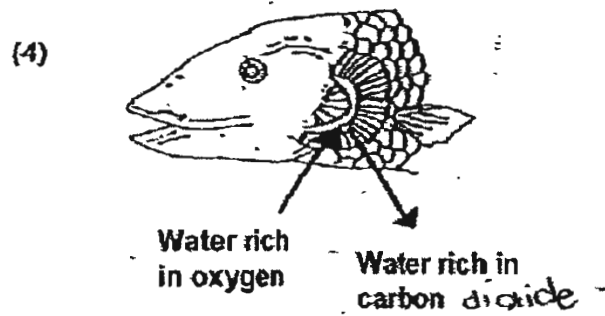
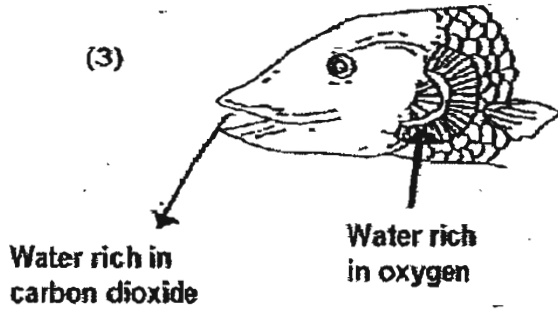
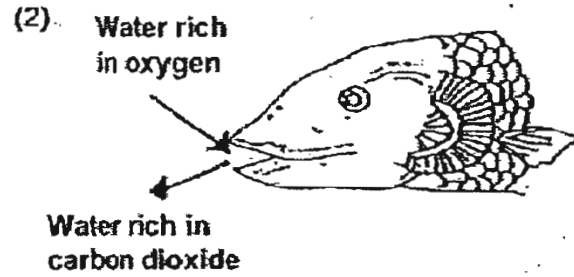
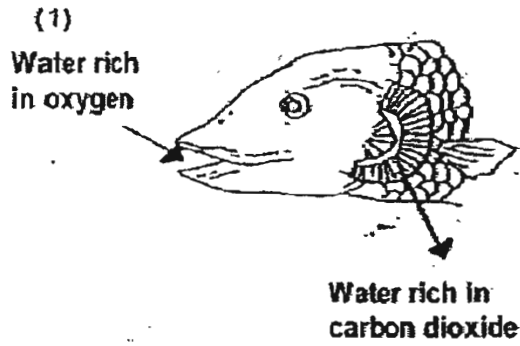

7. Which one of the following gas exists in the greatest amount in the air?

- (1) Oxygen
- (2) Nitrogen
- (3) Water vapour
- (4) Carbon dioxide

8. Which one of the following diagrams shows the flow of air in our body?

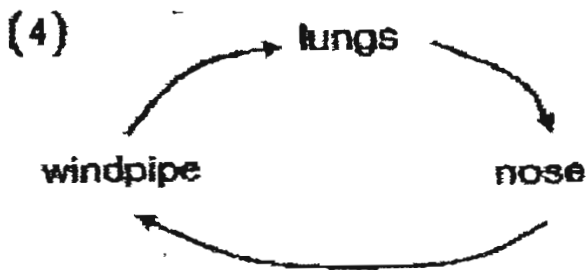
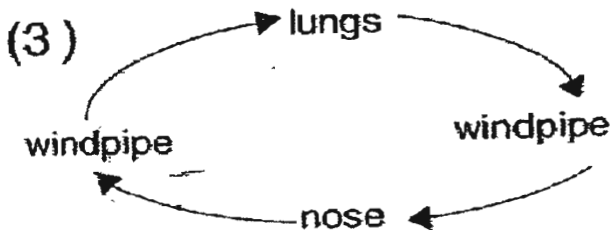
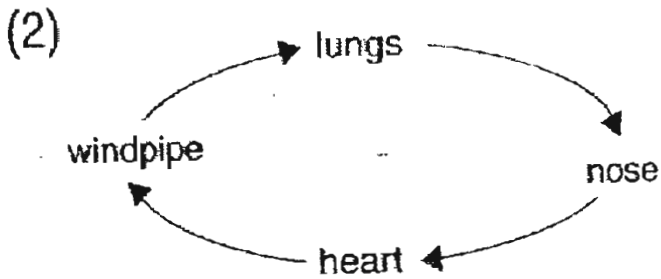
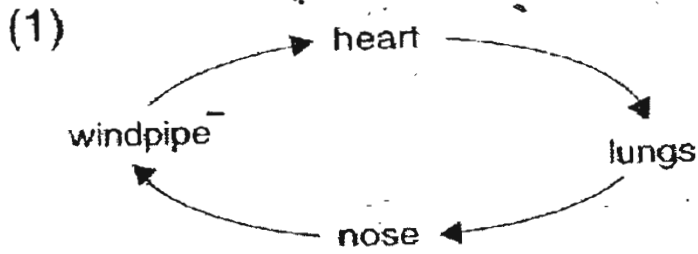

9. When the diaphragm in your chest cavity moves upwards and downwards, _____ is taking place.

- (1) breathing
- (2) circulation
- (3) respiration
- (4) photosynthesis

10. The body's circulatory system consists of _____.

- A. blood
- B. blood vessels
- C. heart
- D. lung

- (1) A and C only
- (2) A, B and C only
- (3) B, C and D only
- (4) All of the above

11. Which of the following describes the circulatory system incorrectly?

- (1) The heart pumps blood rich in carbon dioxide to the lungs.
- (2) Blood vessels are needed to transport blood.
- (3) The waste products are carried away by the blood.
- (4) Blood rich in carbon dioxide is pumped to the rest of the body.

12. When food is made, it is stored in the form of starch.
Iodine is a liquid which turns dark blue when there is starch.
The cut end of a Balsam stem is dipped into some iodine. Some patches of dark blue are seen as in the diagram below.

Study the diagram below and answer questions 12 and 13.

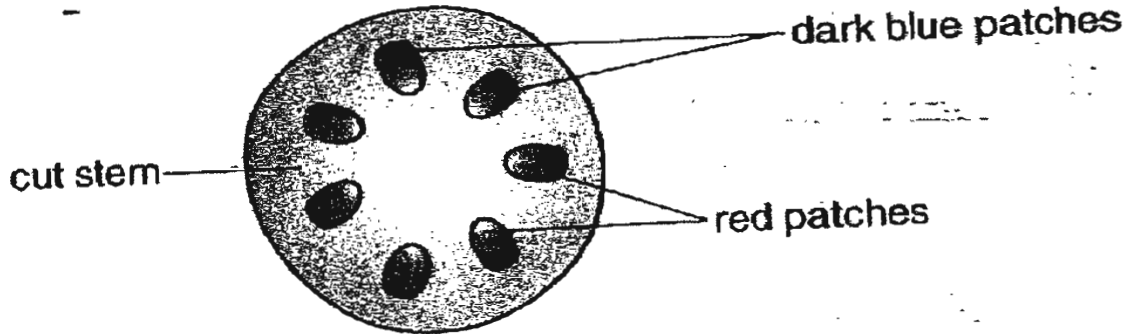

The dark blue patches show us the position of the _____.

- (1) air spaces
- (2) pores
- (3) tubes that carry water
- (4) tubes that carry food

13. The root of the plant was earlier dipped into a bottle of water stained with red ink. The red patches as seen in the cut stem indicate that _____.

- (1) air has entered the red patches
- (2) food is being carried along these tubes
- (3) the tubes which carry water are different from the tubes that carry food
- (4) the tubes which carry water are the same as the tubes that carry food

14. Which of the following activities need energy?

- A: lying in bed
- B: breathing
- C: digestion of food
- D: playing football.

- (1) A and B only
- (2) B and C only
- (3) A, B and D only
- (4) All of the above

15. The following diagram shows one way in which energy is transferred.

Sun → Plant → Grasshopper → Bird → Snake

Which of the following statements about the diagram is true?

- A: The bird gets its energy indirectly from the plant
- B: Only plants get their energy directly from the sun.
- C: Transfer of energy is not possible if there is no sun.
- D: Energy is transferred indirectly from the plant to the snake.

- (1) C only
- (2) B and D only
- (3) A, B and D only
- (4) All of the above

16. Study the flow chart below carefully.

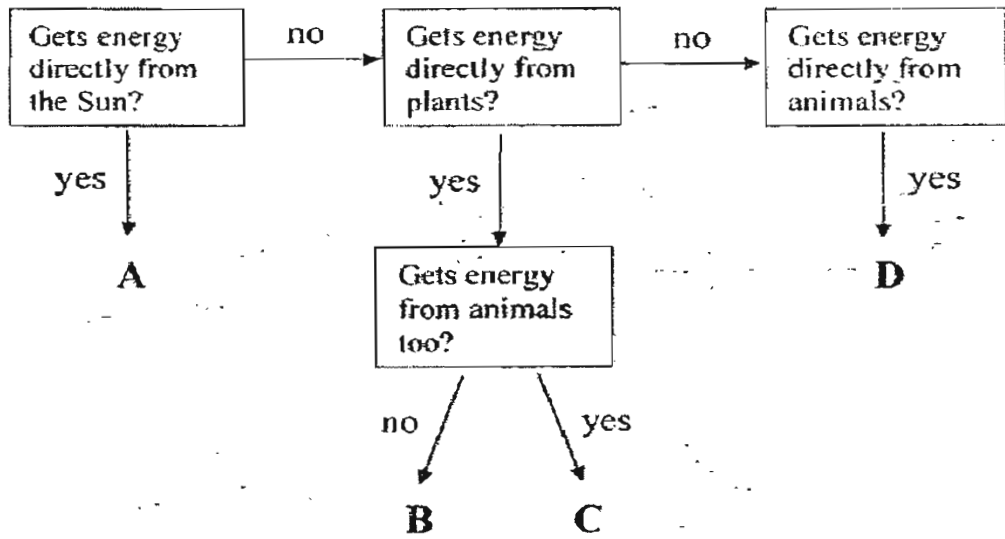

What are A, B, C and D?

	A	B	C	D
(1)	cow	grass	tiger	human
(2)	grass	cow	human	tiger
(3)	grass	human	cow	tiger
(4)	tiger	human	grass	cow

17. Which one of the holes in the wooden block would allow Mary to see the cockroach?

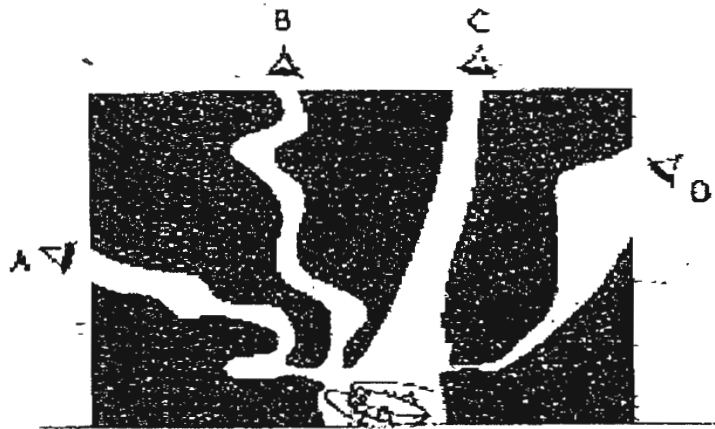

- (1) A
- (2) B
- (3) C
- (4) D

18. A boy stood in front of a display window.



He is able to see what was being displayed behind the window and his reflection in the window at the same time.

He is able to do these because the display window _____.

A: allows light to pass through

B: does not allow light to pass through

C: reflects some light back into his eyes

(1) A only

(2) C only

(3) A and C only

(4) B and C only

19. Study the classification below.

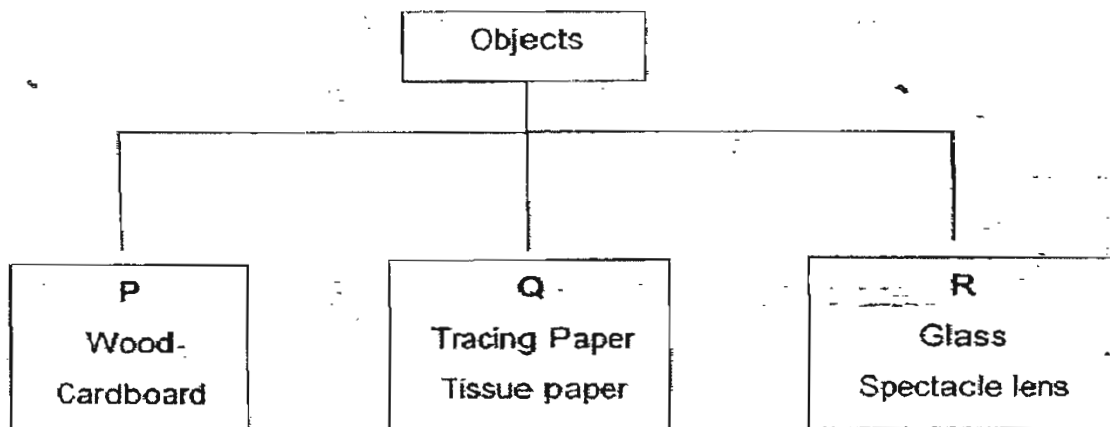

What are the suitable headings for P, Q and R?

	P	Q	R
(1)	Opaque	Transparent	Translucent
(2)	Opaque	Translucent	Transparent
(3)	Translucent	Opaque	Transparent
(4)	Transparent	Opaque	Translucent

20. Sandy set up an experiment to study shadows. She placed a basketball and a glass cube as shown in the diagram below and shone light on the 2 objects. The shadow produced was captured on the screen.

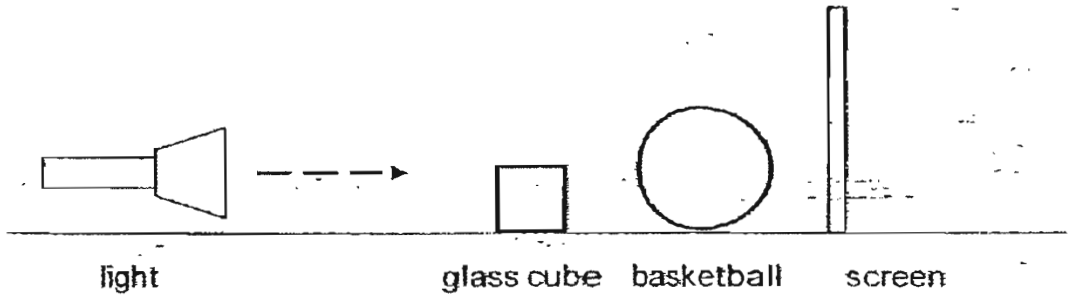

Which one of the following shadows would Mindy see on the screen?

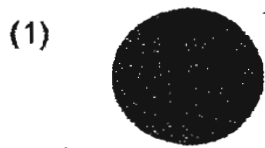

21. Which one of the following graphs correctly shows the changes in the length of a shadow cast by an object during the day?

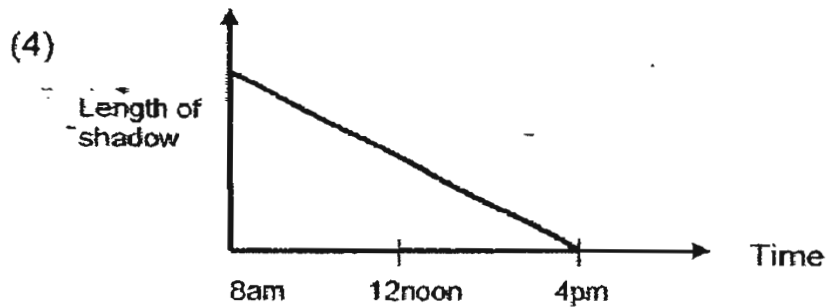
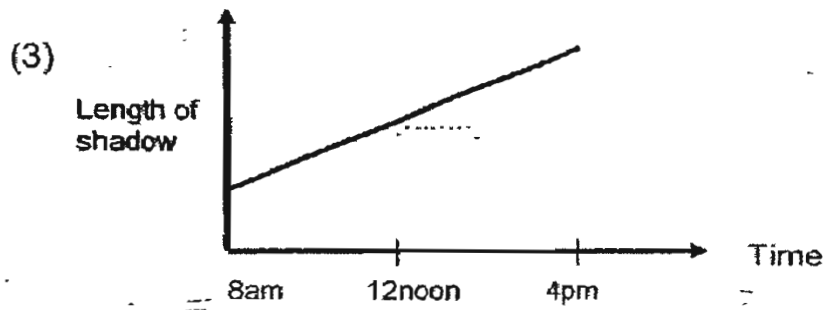
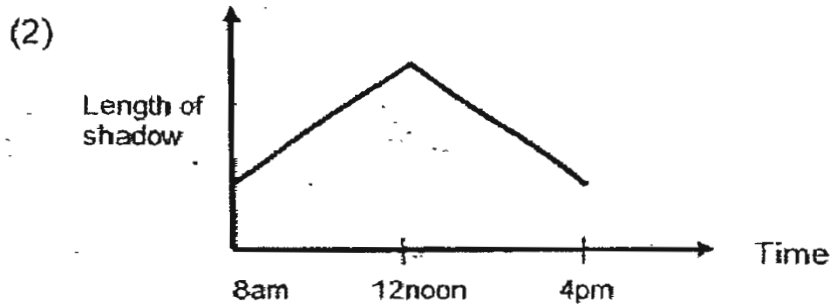
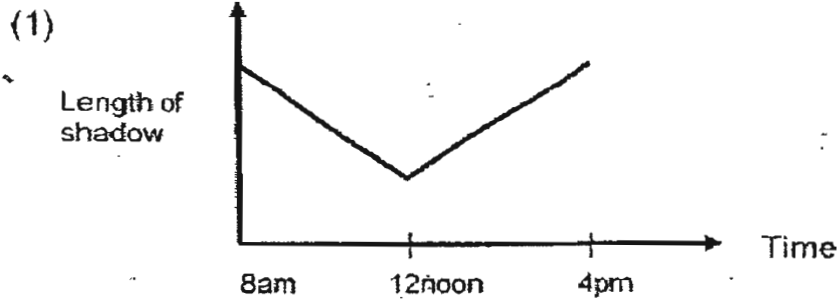

22. Heat is given off by _____.

A: the sun

B: melting ice

C: burning things

D: rubbing a stone against the ground

(1) A and C only

(2) B and D only

(3) A, C and D only

(4) All of the above

23. Look at the diagram of a kettle below. Which part/s of it is most likely made of materials that are poor conductors of heat?

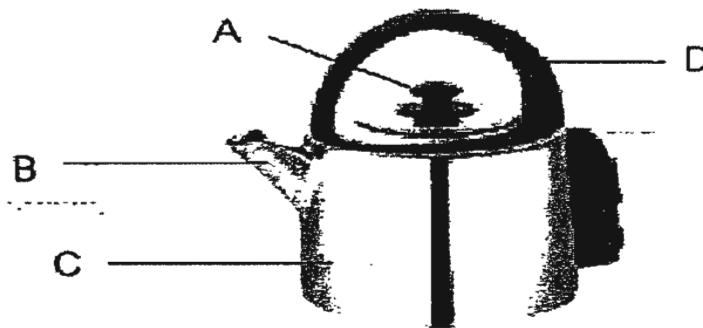

(1) A only

(2) C only

(3) B and C only

(4) A and D only

24. The glasses below are filled with different amounts of water at different temperatures.
Arrange the glasses beginning with the one with the most heat to the least heat?

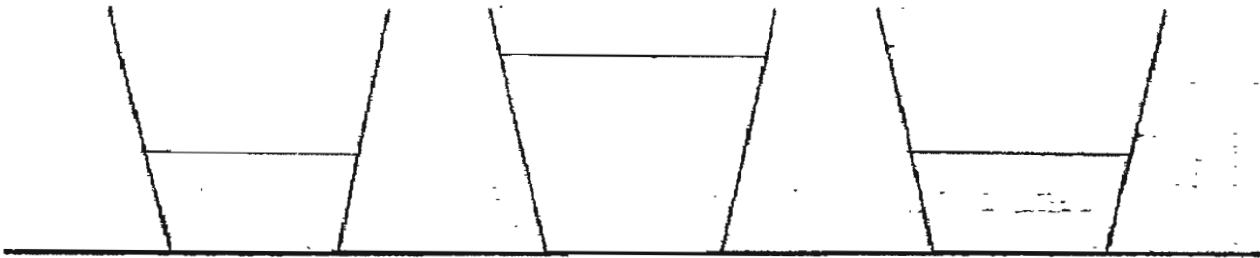

Glass A

40°C

Glass B

70°C

Glass C

70°C

- (1) A, C, B
- (2) B, A, C
- (3) B, C, A
- (4) C, A, B

25. Celine placed a bottle of hot milk into a basin of ice water as shown below. Which of the following statement/s is true?

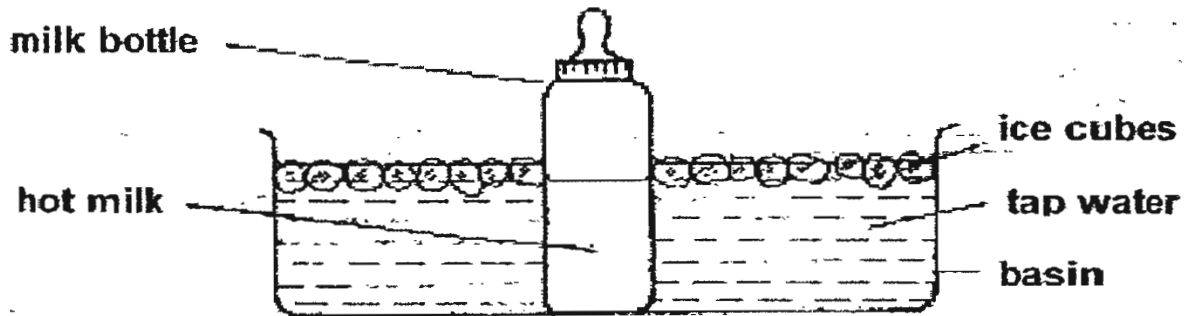

- A: The temperature of the hot milk would decrease for a period of time.
B: The temperature of the tap water would remain unchanged.
C: The ice gained heat from the hot milk, tap water in the basin and surrounding air.
D: The basin was cold when you touched it because your hand lost heat to it.

- (1) A and C only
(2) B and D only
(3) A, B and C only
(4) A, C and D only

26. 2 metal cups are stuck together. Which one of the following would be the fastest method of separating them?

(1)

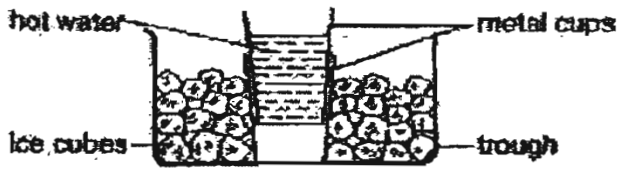

(2)

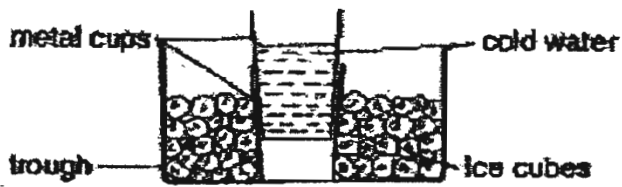

(3)

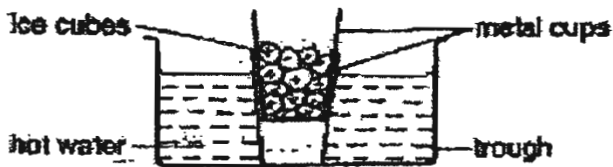

(4)

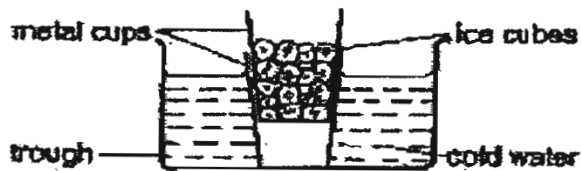

27. Gilbert set up the following experiment as shown below. He heated equal volumes of metal, water and air in different sealed cylinders. He measured and compared the time taken for their temperature to reach 80°C .

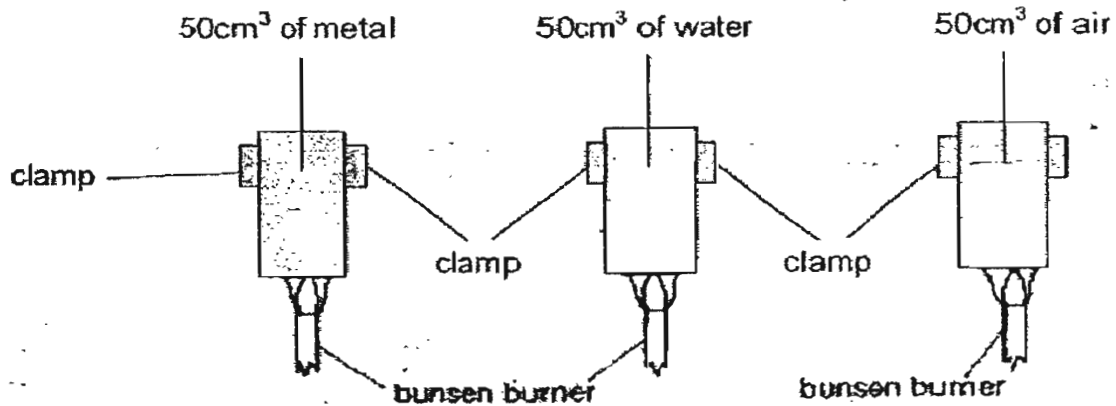

The aim of his experiment was to find out _____

- (1) which type of matter contracts the fastest.
- (2) the boiling points of different types of matter.
- (3) how fast heat travels in different types of matter.
- (4) what happens to different types of matter when they are heated.

28. A cup of hot water was placed in a container of ice cubes as shown in the diagram below.

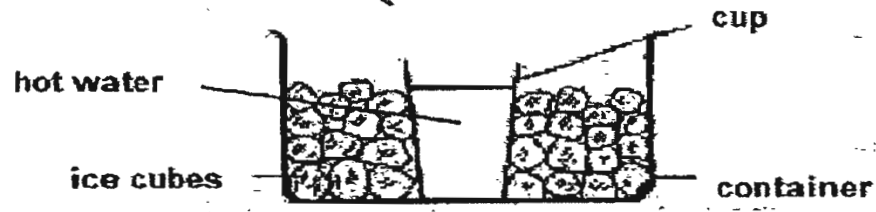

Which one of the following graphs most accurately shows the temperature of the hot water and ice cubes over a period of five hours?

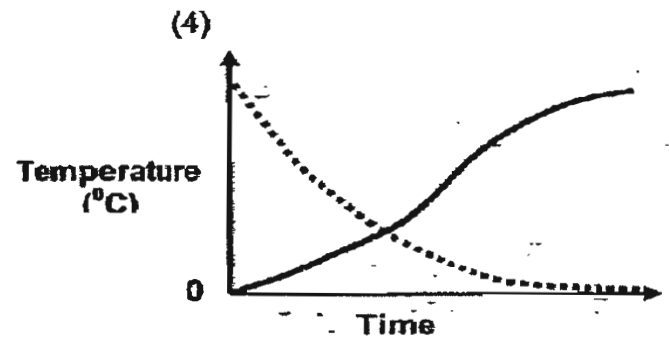
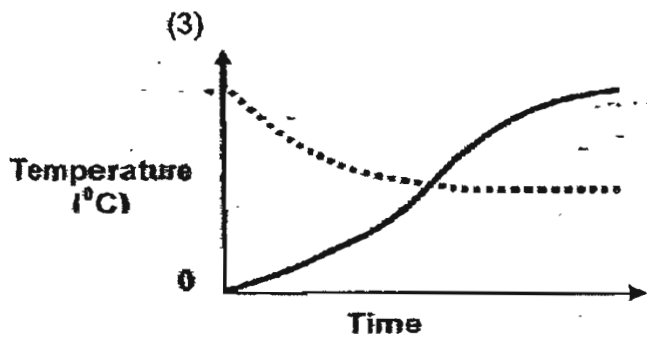
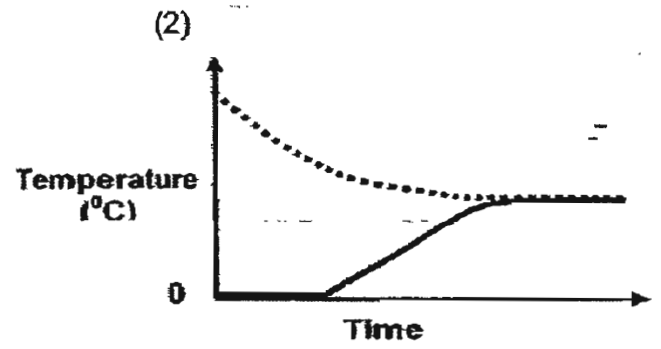
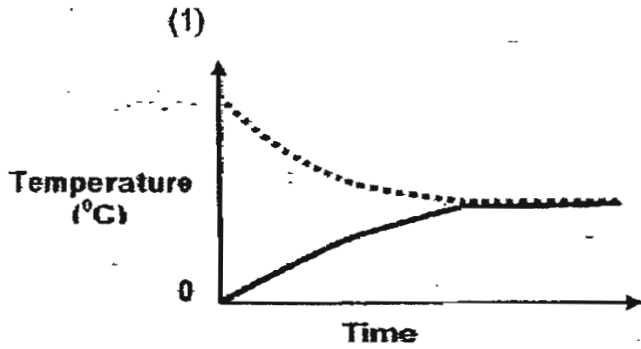

29. Look at the table below.

Waterproof materials	Non- Waterproof materials
plastic glass rubber	aluminum cotton silk

Which materials have been wrongly grouped?

- (1) aluminum
- (2) cotton
- (3) glass
- (4) rubber

30. Which one of the following statements about systems is not true?

- (1) The human body is a system.
- (2) Each part of a system has a function.
- (3) Each part of a system does a job that is different from the rest.
- (4) A system can still work properly even if some parts are not working.



HENRY PARK PRIMARY SCHOOL

SEMESTRAL EXAMINATION 2.

2007

SCIENCE

PRIMARY 4

BOOKLET B

Name: _____ ()

Class: Primary 4 _____

**16 Questions
40 Marks**

Total Time for Booklets A and B: 1 h 30 min

DO NOT OPEN THIS BOOKLET UNTIL YOU ARE TOLD TO DO SO.

READ AND FOLLOW INSTRUCTIONS CAREFULLY.

- **PART 2 (40 marks)**

- Write your answers to questions 31 to 46 in the spaces given.

31. Mary poured some boiling water into a glass beaker. She placed an aluminium foil over the beaker. Then she put a few pieces of ice onto the aluminium foil. After a few minutes, she noticed that some water droplets were formed.

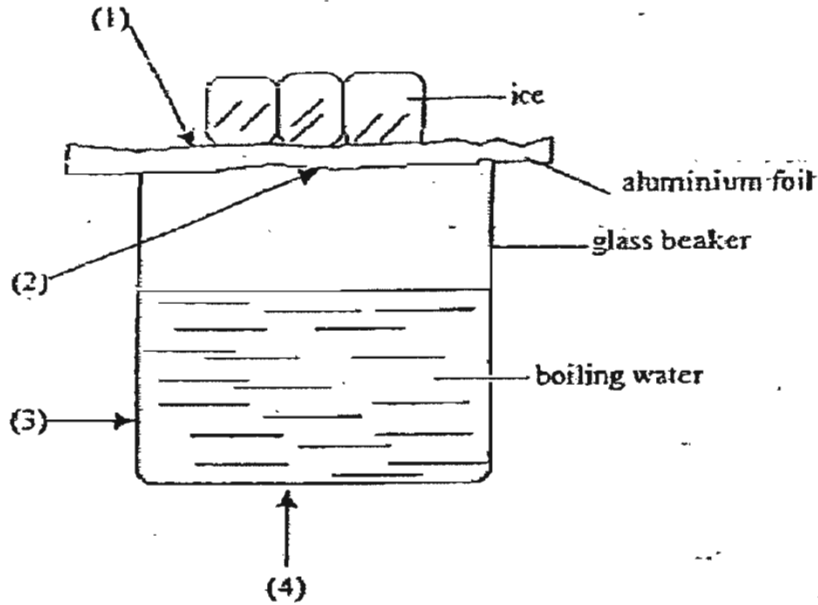

a. At which point would she find most water droplets? (1m)

b. Explain how the water droplets were formed. (2m)

32. State one similarity between evaporation and boiling of water? (1m)

33. Some ice cubes were left on the table for twenty minutes. The graph below shows the temperature of the ice cubes.

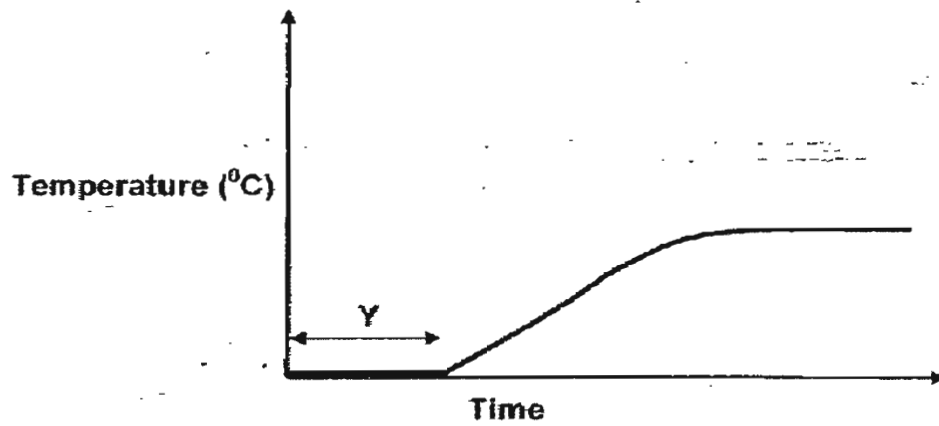

- a. Is there heat gain or heat loss during the process that is taking place at Y? (1m)

- b. White clouds could be seen around the ice cubes in the first ten minutes. Explain how the white clouds were formed. (1m)

34. The following experiment is carried out.

Three towels of the same size were hung out to dry in the same place.

Towel A was fully open, Towel B was folded once and Towel C was folded twice as shown below.

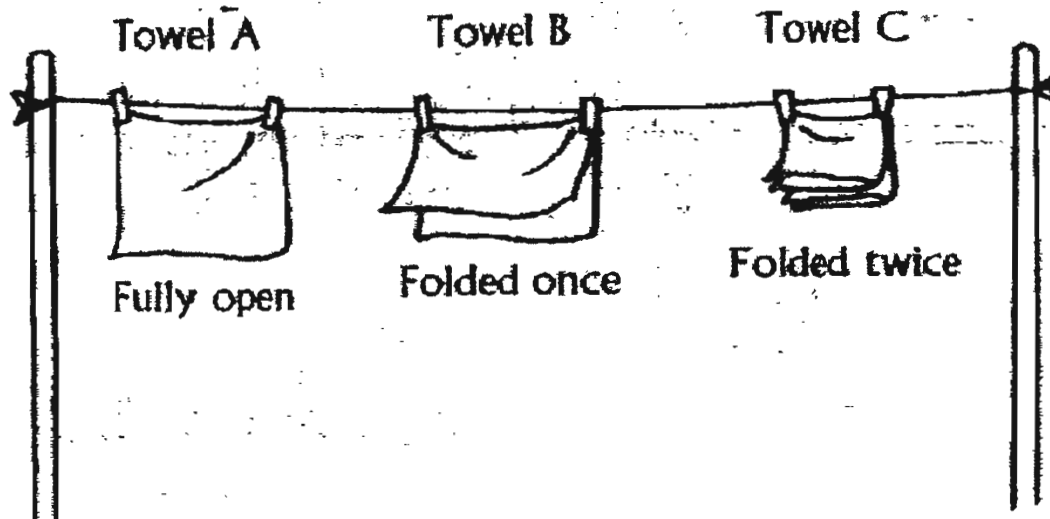

a. What is the purpose of the experiment? (1m)

b. What is the measured variable of this experiment? (1m)

35. The diagram shows how blood travels in the body.

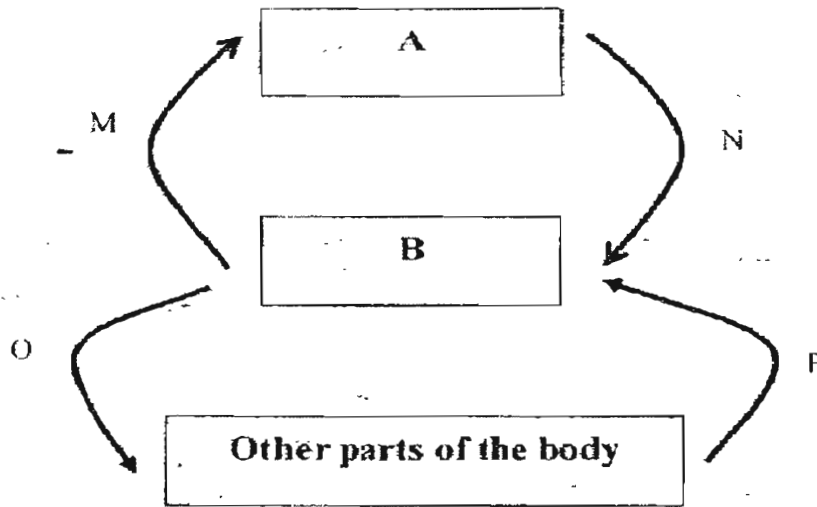

Arrows **M, N, O, P** represent the movement of blood. **A** and **B** represent two organs.

a. Name the organs which **A** and **B** represent. (1m)

A: _____

B: _____

b. Which arrow(s) represent the movement of blood rich in oxygen? (1m)

36. John ran 1.6km during his NAPFA test. The graph below shows his pulse rate during the run and ten minutes after the run.

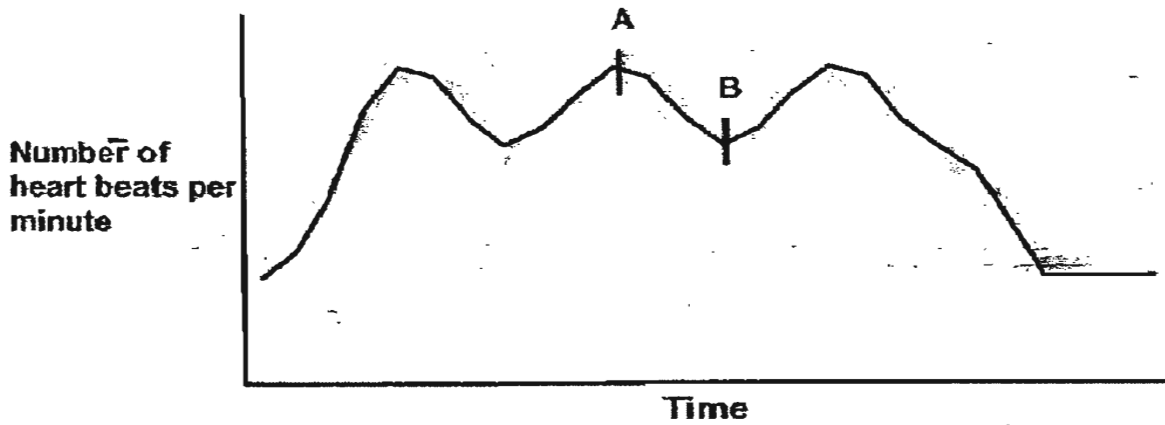

a. Suggest what could happen to cause his heart beat to decrease between point A and B during the run. (1m)

b. Explain why the number of heart beat per minute increase when we exercise. (1m)

37. Write down the systems that the following body parts belong to. (1m)

	Body part	System
(a)	Windpipe	
(b)	Blood Vessel	

38. The diagram below shows a picture of a gill and a lung. Look at the enlarged sections of the gill and lung, state a **difference** between their structures. (1m)

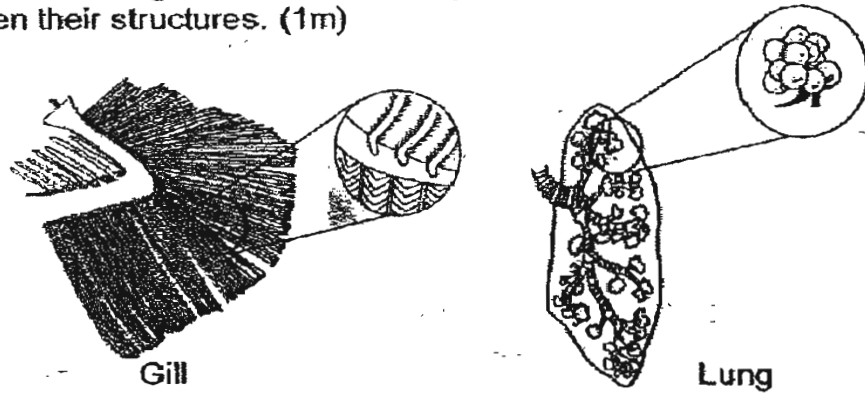

39. John set up the experiment below. A pot of plant was placed in a dark cupboard while another was placed under a light source. He was told that limewater turns chalky when carbon dioxide is present.

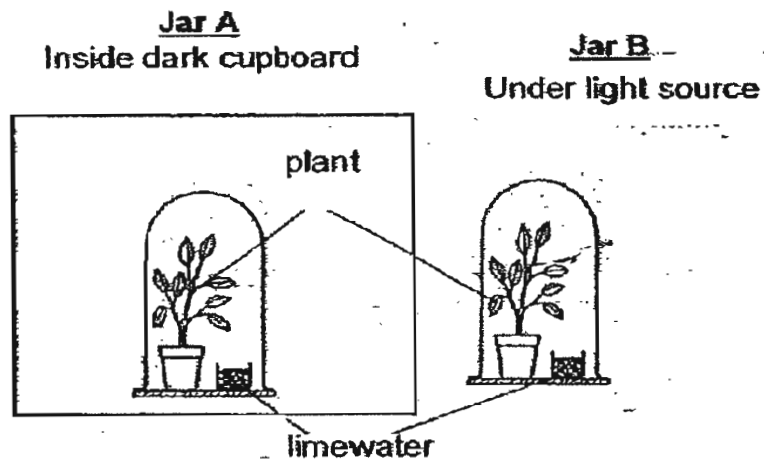

- a. In which jar (A or B) will the limewater turn chalky first? (1m)

- b. Explain your answer in part (a). (1m)

40. Four students were in a pitch-dark room where they could not see anything. One of them switched on a torchlight and now the students were able to see the things around them.

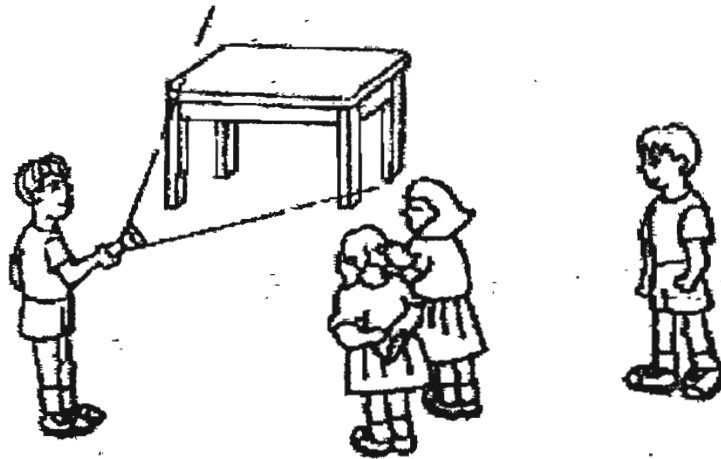

- a. Explain why they were able to see the table and each other when the torchlight was switched on. (2m)

- b. Draw in the box the reflected image of the word 'STAR'. (1m)

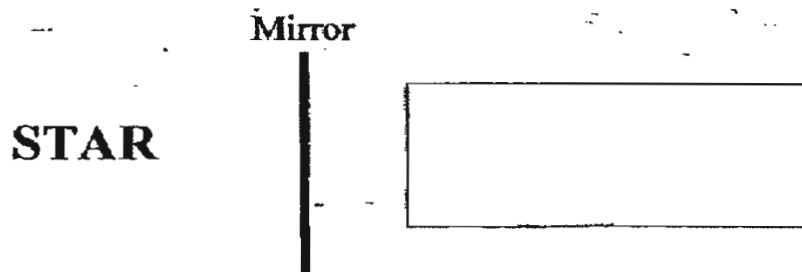

41. A metal container is arranged in two different ways in front of a light source to cast different shadows on the screen.

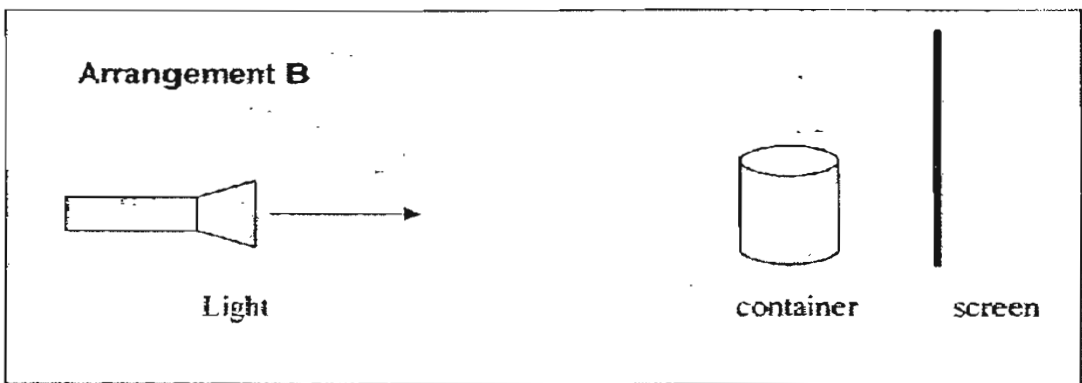
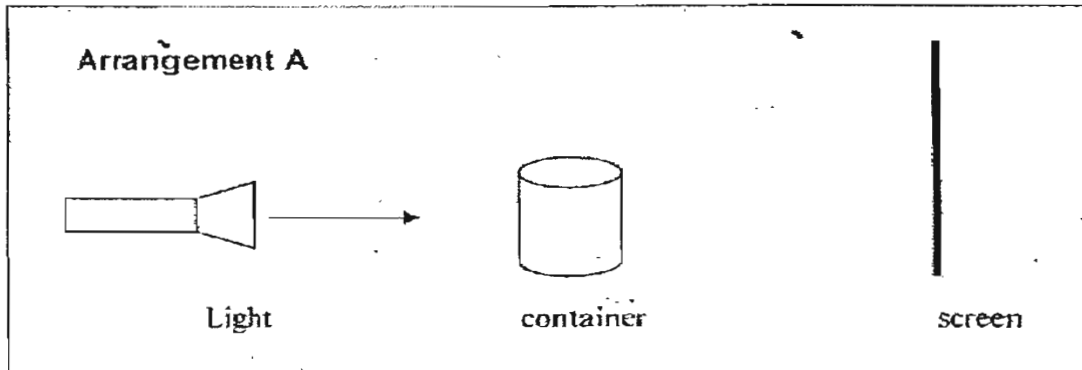

a. State one similarity and one difference between the shadows formed in Arrangement A and Arrangement B. (2m)

Similarity: _____

Difference: _____

b. Describe in what way the shadow would be different if a frosted glass container is used in Arrangement A. (1m)

c. Explain your answer in (b). (1m)

42. Ken set up the experiment as shown below to investigate the transparency of different liquids. He switched on the torchlight and recorded what he saw on the white paper in the table below.

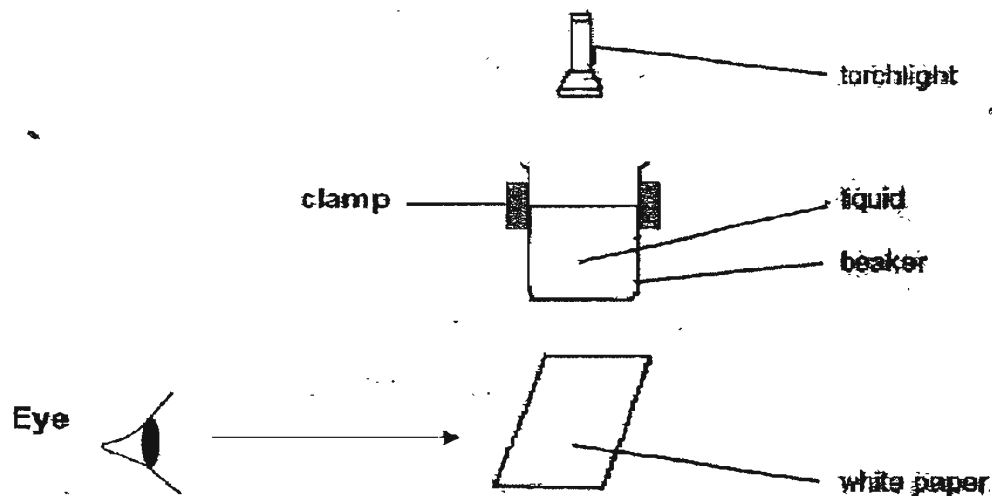

Liquid	W	X	Y	Z
What he saw on the white paper	Bright light	Faint light	No light	Faint light

a. What is the test variable of his experiment? (1m)

b. State one variable he must keep the same to ensure a fair test? (1m)

c. Ken dropped a coin into the different liquids. In which beaker of liquid (W, X, Y or Z) would he not see the coin at all? (1m)

d. Explain your answer in (c). (1m)

43a. Samantha set up the following experiment. She placed a drop of red ink in the middle of the glass tube connecting the two flasks X and Y.

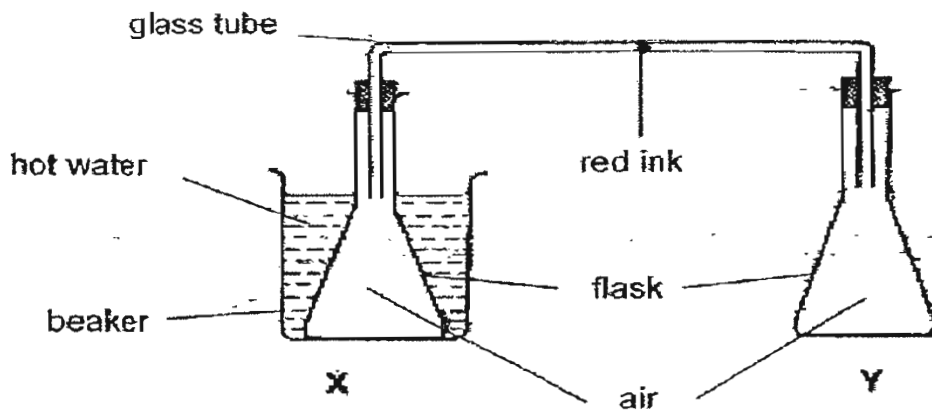

State what would happen to the drop of red ink. (1m)

ii. Explain your answer in (a). (1m)

- b. June was walking home from school when she noticed cracks on the concrete pavement like those shown in the picture below.



- i. Explain why the concrete pavement cracked? (1m)

- ii. What can be done to prevent such cracking? (1m)

44. Ali tested four containers made of different materials (P, Q, R and S) to see which one can prevent ice from melting for the longest period of time. He recorded the time taken for the ice to melt completely in each container.

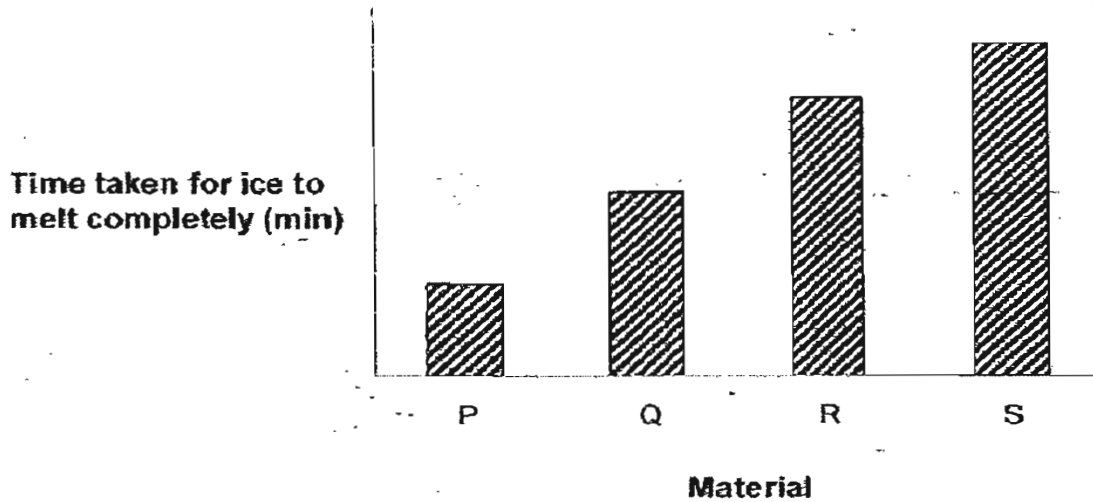

- a) Which material is the best conductor of heat? (1m)

- b) Explain your answer in (a). (1m)

- c) Which material (P, Q, R or S) should he choose to make an icebox to keep his soft drinks cool when he goes on a picnic? (1m)

- d) State the measured variable for this investigation. (1m)

45.

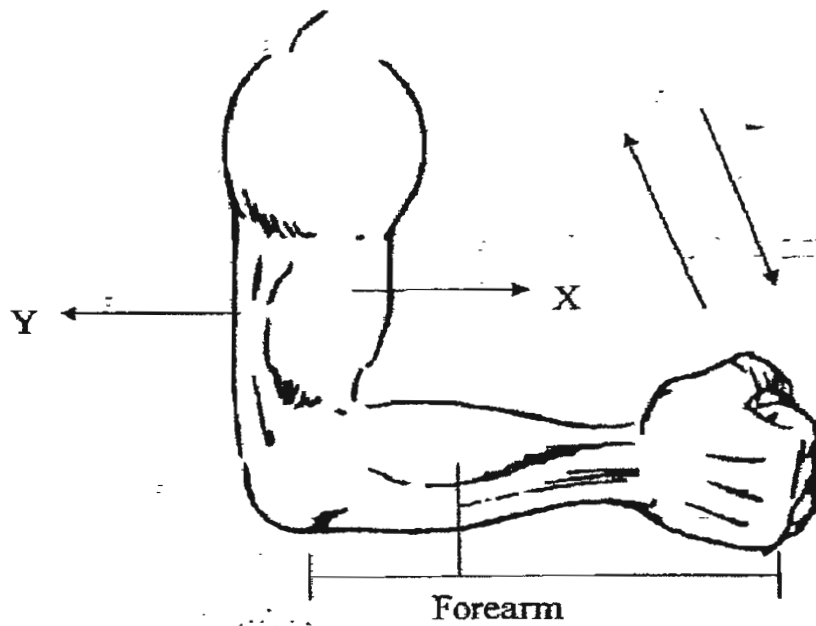

a. Looking at the diagram above, when X contracts, Y _____ (1m)

b. Name the type of joint that enables only the forearm to move up and down? (1m)

46a. Look at the diagram below.

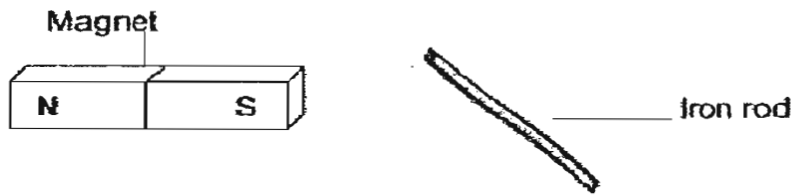

Using the magnet, how can Jayce make the iron rod into a magnet? (1m)

b. Madam Heng set up the following experiment below.

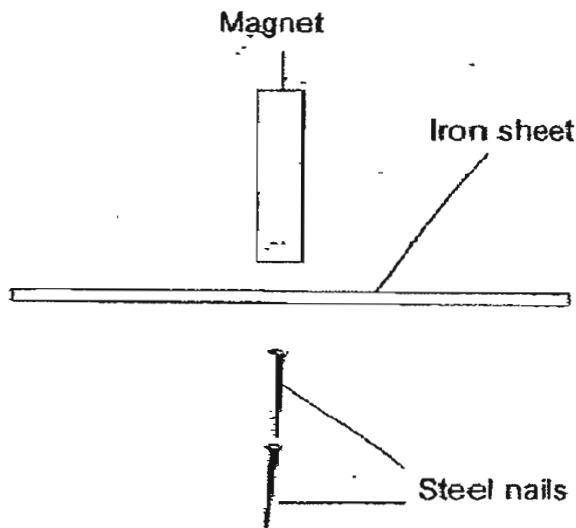

i. Will the steel nails be attracted to the magnet? (1m)

ii. Explain your answer in (bi). (1m)



ANSWER SHEET

HENRY PARK PRIMARY SCHOOL - PRIMARY 4 SCIENCE 2007
SEMESTRAL ASSESSMENT (2)

1. 4
 2. 4
 3. 3
 4. 1
 5. 2
 6. 1
 7. 2
 8. 3
 9. 1
 10. 2
 11. 4
 12. 4
 13. 4
 14. 4
 15. 3
 16. 2
 17. 1
 18. 3
 19. 2
 20. 1
 21. 1
 22. 3
 23. 4
 24. 3
 25. 4
 26. 3
 27. 3
 28. 2
 29. 1
 30. 4
- 31) a) Point 2
b) Boiling water evaporated to form water vapour. water vapour is cooled the aluminium foil with the ice and condense to water.
- 32) They cause a change from liquid to gas.
- 33) a) Heat gain.
b) Warmer surrounding water vapour condenses when it meets the cooler part around the ice cubes.
- 34) a) To find out if the area of exposed surface will affect the rate of evaporation.
b) The time taken for towel to dry.
- 35) a) A: lungs B: heart
b) Arrow N and O
- 36) a) The cause that his heart beat decrease between point A and point B is he stop running and started jogging.
b) Our heart have to pump oxygenated blood to the rest of his body to release more energy.
- 37) a) respiration system.
b) circulatory system.

38) The sills are made of feather like structures but the lungs are made of spongy like structures.

39) a) Jar A

b) The plant takes in oxygen and gives out carbon dioxide during respiration.

40) a) The path of light and the objects must be correctly stated to obtain.

b) QNTC

41) a) Similarity: The shape of the shadows is the same.
Different: Arrangement A shadow on the screen will be big but Arrangement B will be small.

b) The shadow will be lighter dark not very dark.

c) Frosted glass is translucent.

42) a) The types of liquids used.

b) Must use the same energy from the torchlight.

c) Beaker Y.

d) Liquid Y is opaque.

43) a) i) The drop of red ink would move towards flask Y.

ii) The air in flask X expands pushing the ink towards flask Y.

b) i) It expands when it is hot and cracks as there is no space for it to expand.

ii) Build them in small for expansion and contraction.

44) a) Material P

b) The ice melts in the shortest amount of time.

c) Material S.

d) The time taken for ice to melt completely.

45) a) relaxes.

B) Hinge joint.

46) a) Jayce must use the magnet to stroke the iron rod in the same direction.

b) i) No.

ii) Magnetism cannot pass through magnetic materials.