



AI TONG SCHOOL

2011 SEMESTRAL ASSESSMENT (2) PRIMARY FOUR SCIENCE

DURATION : 1hr 45 min

DATE: 31st October 2011

INSTRUCTIONS

**Do not open the booklet until you are told to do so.
Follow all instructions.
Answer all questions.**

Name : _____ ()

Class : Primary _____

Parent's Signature : _____

Date : _____

| | |
|--------------|------------|
| MARKS | |
| | 100 |

Section A (30 x 2 marks)

For each question from 1 to 30, four options are given. One of them is the correct answer. Make your choice (1, 2, 3 or 4). Shade the correct oval (1, 2, 3 or 4) on the Optical Answer Sheet.

1. Which one of the following properties is not true for both oil and a book?

- (1) They can be seen.
- (2) They take up space.
- (3) They have fixed shapes.
- (4) They have fixed volumes.

2. The diagrams below show the growth of a frog with two missing stages A and B.

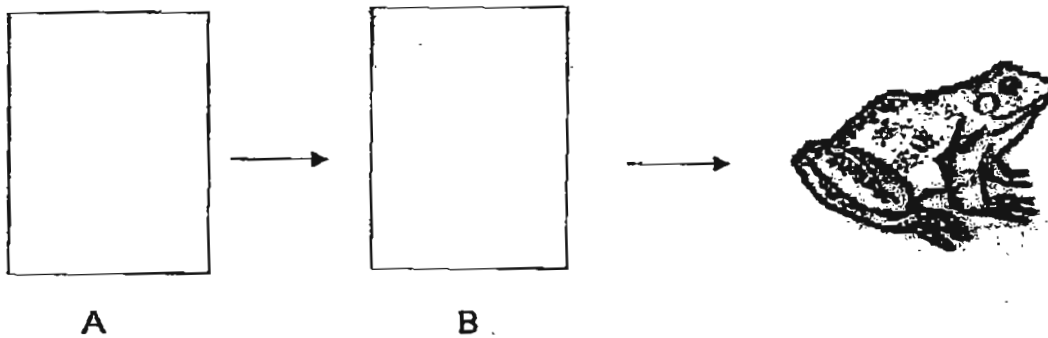

Which one of the following shows the correct stages for A and B?

| | A | B |
|-----|---|---|
| (1) | | |
| (2) | | |
| (3) | | |
| (4) | | |





3. Joints are important because they _____.

- (1) protect the bones
- (2) strengthen the bones
- (3) support the muscles as you move
- (4) allow bones to move in various directions

4. Ralph shines light from a torch on the wooden object as shown below.



Which one of the following shows the shadow of the wooden object on the screen?

- (1) 
- (2) 
- (3) 
- (4) 

5. Ali boiled some water in the metal pot shown below.

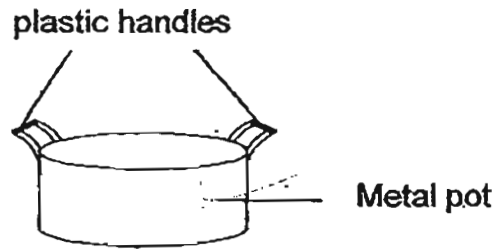

He used a metal pot because it is a good conductor of heat that is described as a substance which _____

- (1) melt easily
- (2) loses heat slowly
- (3) slows down heat gain
- (4) allows heat to pass through easily

6. Which one of the following is a living thing?

(1) Rabbit



(2) Book



(3) Plastic spoon



(4) Porcelain cup



7. Which one of the animals shown below is **NOT** an insect?

(1)



(2)











(3)



(4)



8. The table below shows some animals which are classified into different groups, A, B and C.

| Group A | Group B | Group C |
|---|---|---|
|  |  |  |
|  |  |  |
|  |  |  |

Based on the table above, how are these animals grouped?
They are grouped according to _____.

- (1) their size
- (2) their outer coverings
- (3) the place they live in
- (4) the number of legs they have

9. The chart below shows how some objects are classified.

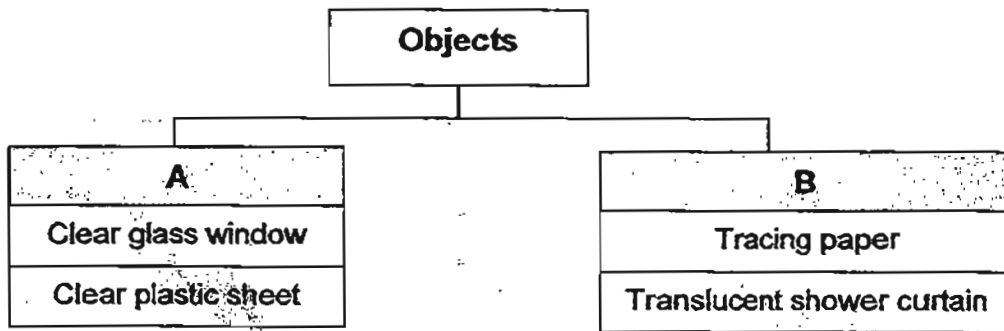

Which one of the following objects can be placed in Group B?

- (1) Mirror
- (2) Cardboard
- (3) Paper plate
- (4) Frosted glass

10. Which of the following mixture of objects can we use a magnet to separate?

- (1) Iron pins and copper nails
- (2) Iron pins and steel needles
- (3) Copper nails and wooden toothpicks
- (4) All of the above

11. Ron filled two beakers, A and B, with 250cm^3 of water each. He left Beaker A at room temperature and placed Beaker B in a freezer. After 6 hours, both beakers were tilted sideways.

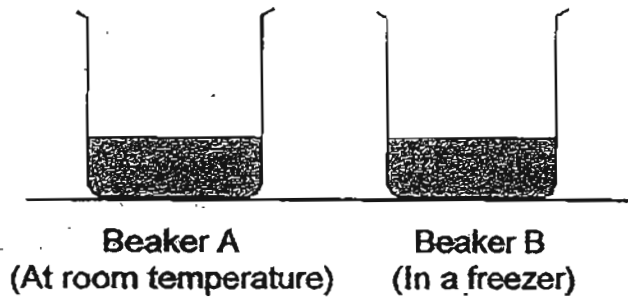

Which of the following shows the correct water level?

(1)

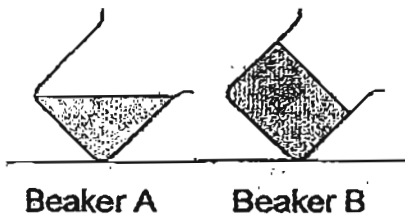

(2)

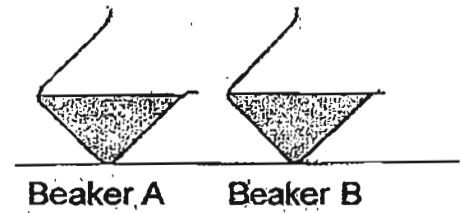

(3)

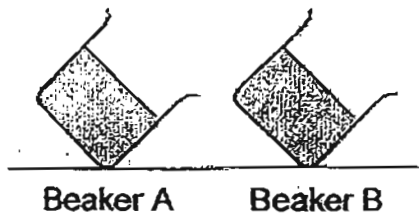

(4)

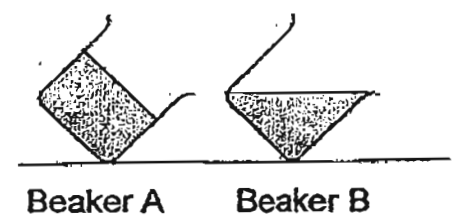

12. Study the flowchart below.

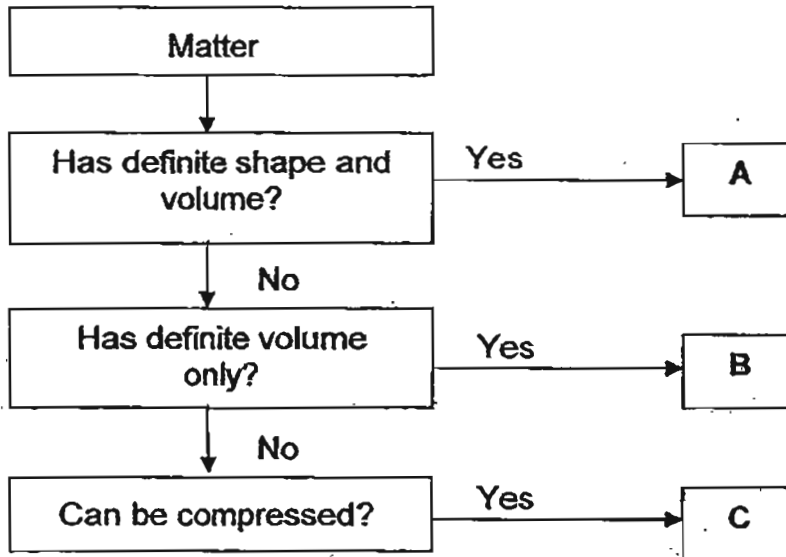

Which one of the following represents A, B and C?

| | A | B | C |
|-----|-------------|-------|--------------|
| (1) | Paper clip | Air | Orange juice |
| (2) | Apple juice | Apple | Nitrogen |
| (3) | Spoon | Milk | Oxygen |
| (4) | Hammer | Water | Orange |

13. Each of the following jars contains five seeds. Jar B, C and D are placed near the window while Jar A is placed in the refrigerator.

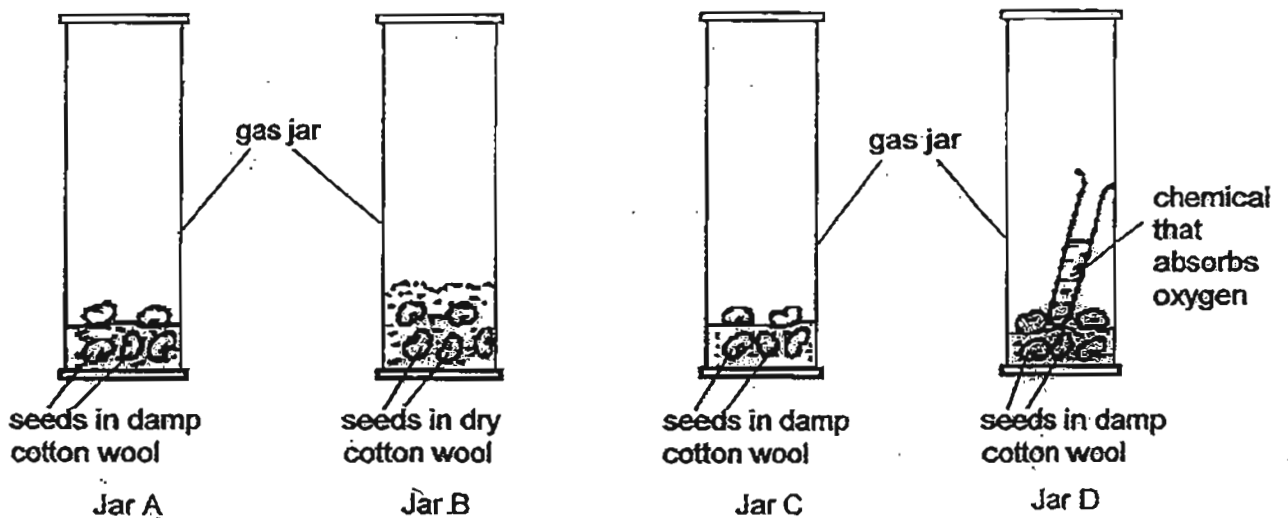

In which jar will the seeds be able to develop into seedlings?

- (1) A
- (2) B
- (3) C
- (4) D

14. Belinda set up an experiment using 4 rooms with the following conditions:

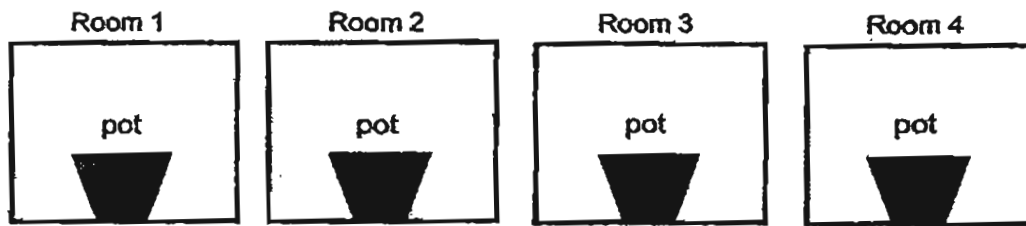

| | Room 1 | Room 2 | Room 3 | Room 4 |
|--|---------------------|---------------------|---------------------|---------------------|
| Number of bean seeds in the pot | 10 | 10 | 10 | 10 |
| Size of room | 10 m ³ | 10 m ³ | 10 m ³ | 10 m ³ |
| Temperature of room | 60 °C | 30 °C | 20 °C | 7 °C |
| Amount of water given to the bean seeds every day | 70 ml | 70 ml | 70 ml | 70 ml |
| Amount of soil in the pot | 300 cm ³ | 300 cm ³ | 300 cm ³ | 300 cm ³ |
| Type of soil in the pot | Garden soil | Garden soil | Garden soil | Garden soil |

The aim of the experiment is to find out if the _____ affects the growth of the seeds.

- (1) type of soil
- (2) amount of soil
- (3) amount of water
- (4) surrounding temperature

15. Four children, Alice, Beckham, Charles and Dennis each made a statement about the human body systems.

Alice: It supports the body.

Beckham: It removes waste materials from the body.

Charles: It gives shape to the body.

Dennis: It takes oxygen into the body.

Which two children made the correct statements about the function of the skeletal system?

- (1) Alice and Beckham
- (2) Alice and Charles
- (3) Charles and Dennis
- (4) Beckham and Charles

16. The experiment shown below was carried out in a dark room.

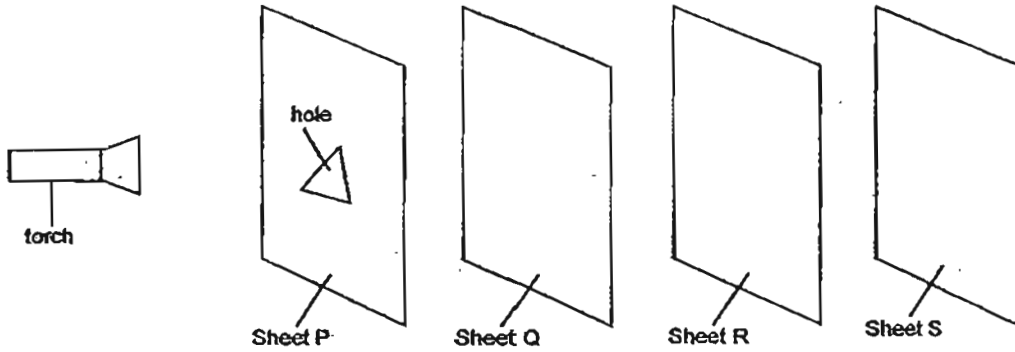

Sheets P, Q, R, and S were placed in a straight line. When the torch was switched on, a bright triangular patch of light was observed on **Sheet R** only. Which one of the following correctly describes the properties of the materials that Sheets P, Q, R and S are made of?

| | Allows light to pass through | Does not allow light to pass through | Not possible to tell |
|-----|------------------------------|--------------------------------------|----------------------|
| (1) | P and Q | S | R |
| (2) | P and S | R | Q |
| (3) | Q | R | P and S |
| (4) | Q | P and R | S |

17. Which one of the lines below best represents the relationship between the amount of light and the depth of a pond ?

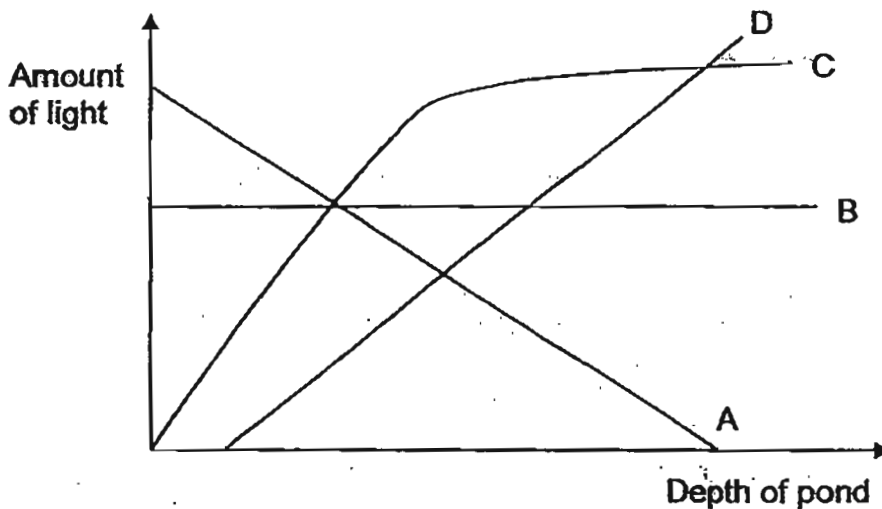

- (1) A
- (2) B
- (3) C
- (4) D

18. Marcus sets up the following experiment. He places the rectangular opaque object at different positions, 1, 2, 3 and 4. He measures and records the height of the shadow of the rectangular opaque object at which it is being placed at the respective positions.

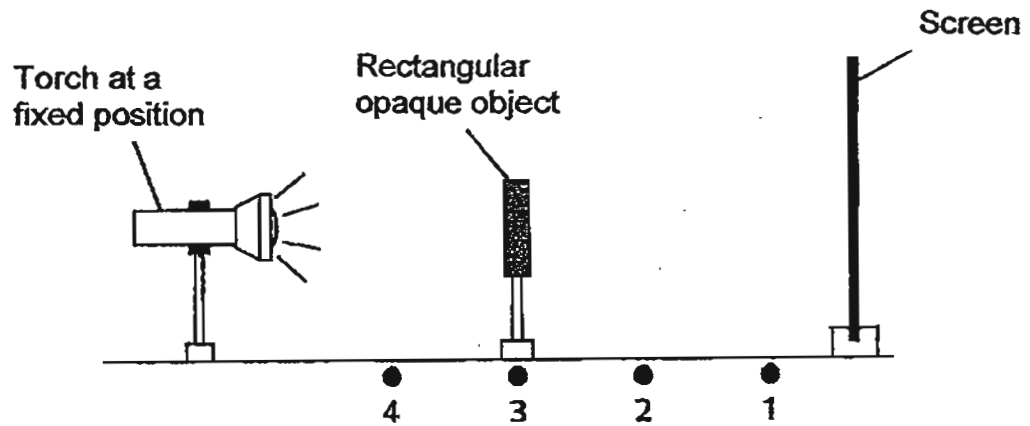

Which graph correctly shows how the height of the shadow of the rectangular block of wood changes with the positions 1, 2, 3 and 4?

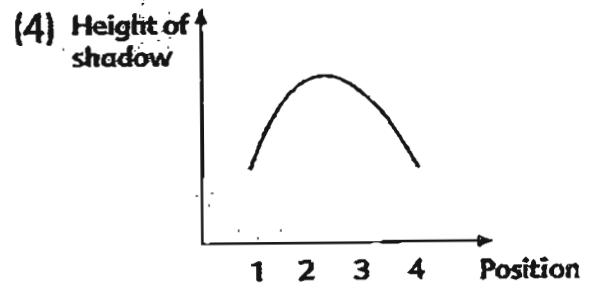
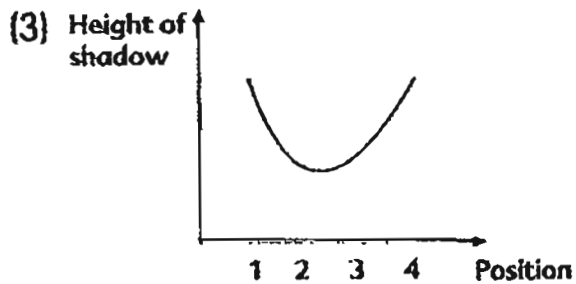
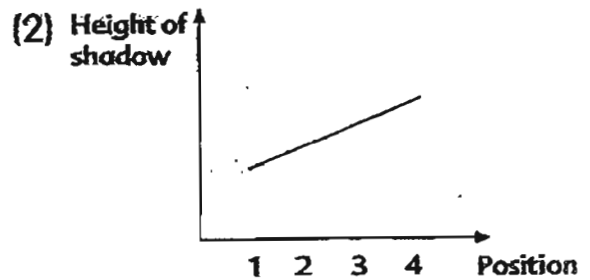
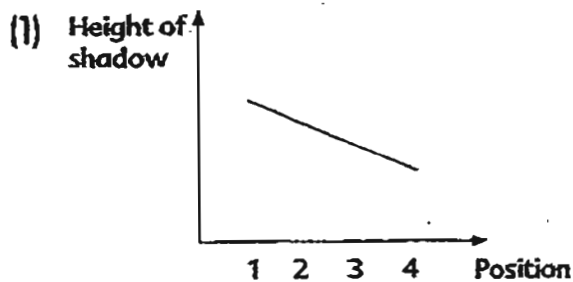

19. Victor left a beaker of boiling water on the table to cool. He recorded the temperature of the water at regular intervals.

Which one of the following graphs shows correctly the change in temperature of the water in the beaker?

(1)

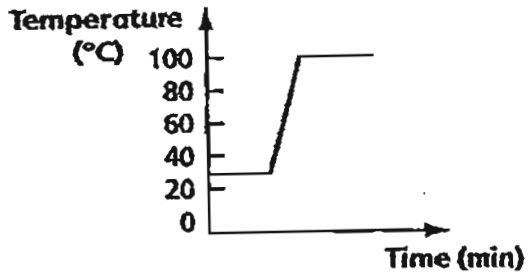

(2)

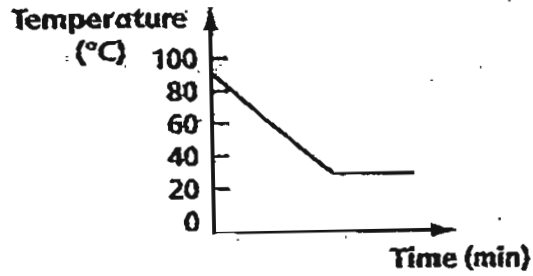

(3)

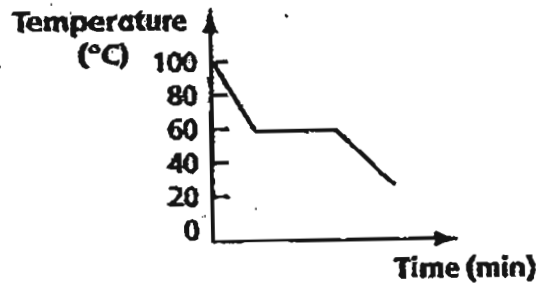

(4)

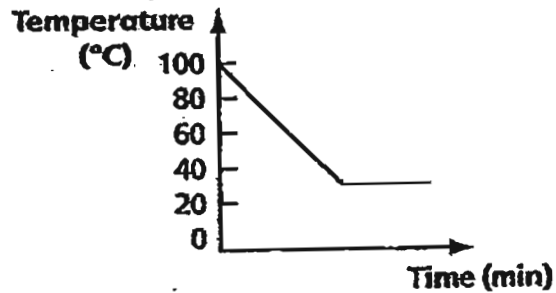

20. Mrs. Wong conducted an experiment using the set-up shown below. 4 iron nails were attached to the ends of 4 iron rods using hardened wax. The 4 rods, namely, S, T, U and V, are each made from different materials.

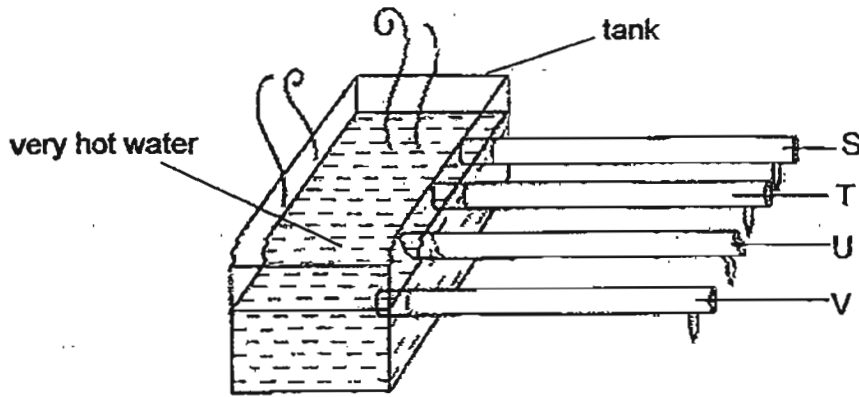

The time taken for the wax to melt at each end of the rod was taken. What was Mrs. Wong trying to find out from this experiment?

- (1) Direction of heat flow.
- (2) Water could conduct heat.
- (3) Which rod was the best conductor of heat.
- (4) The temperature at which the wax would melt.

21. Study the set-ups A and B below.

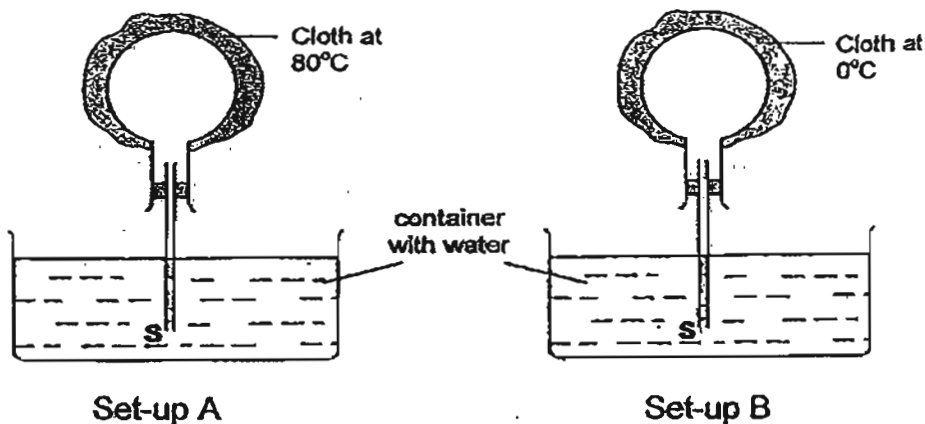

Which one of the following could be observed a few minutes after the cloth was wrapped on the flask in Set-ups A and B?

| | Observation for Set-up A | Observation for Set-up B |
|-----|-------------------------------|-------------------------------|
| (1) | Water rises up the tube | Bubbles escape from tube at S |
| (2) | Water rises up the tube | Water rises up the tube |
| (3) | Bubbles escape from tube at S | Water rises up the tube |
| (4) | Bubbles escape from tube at S | Bubbles escape from tube at S |

22. Two different insects, X and Y, were put into two separate beakers with the same number of leaves.

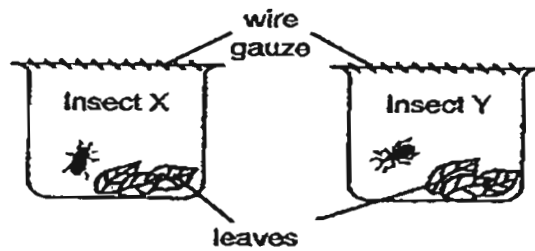

After one week, Insect X was dead but Insect Y was still alive. What can you conclude about Insects X and Y?

- (1) Insect X feeds on plants but Insect Y feeds on animals.
- (2) Insect X feeds on animals but Insect Y feeds on plants.
- (3) Insect X did not have enough air as compared to Insect Y.
- (4) Insect X did not have enough water as compared to Insect Y.

23. The diagram below shows a classification chart of some living organisms.

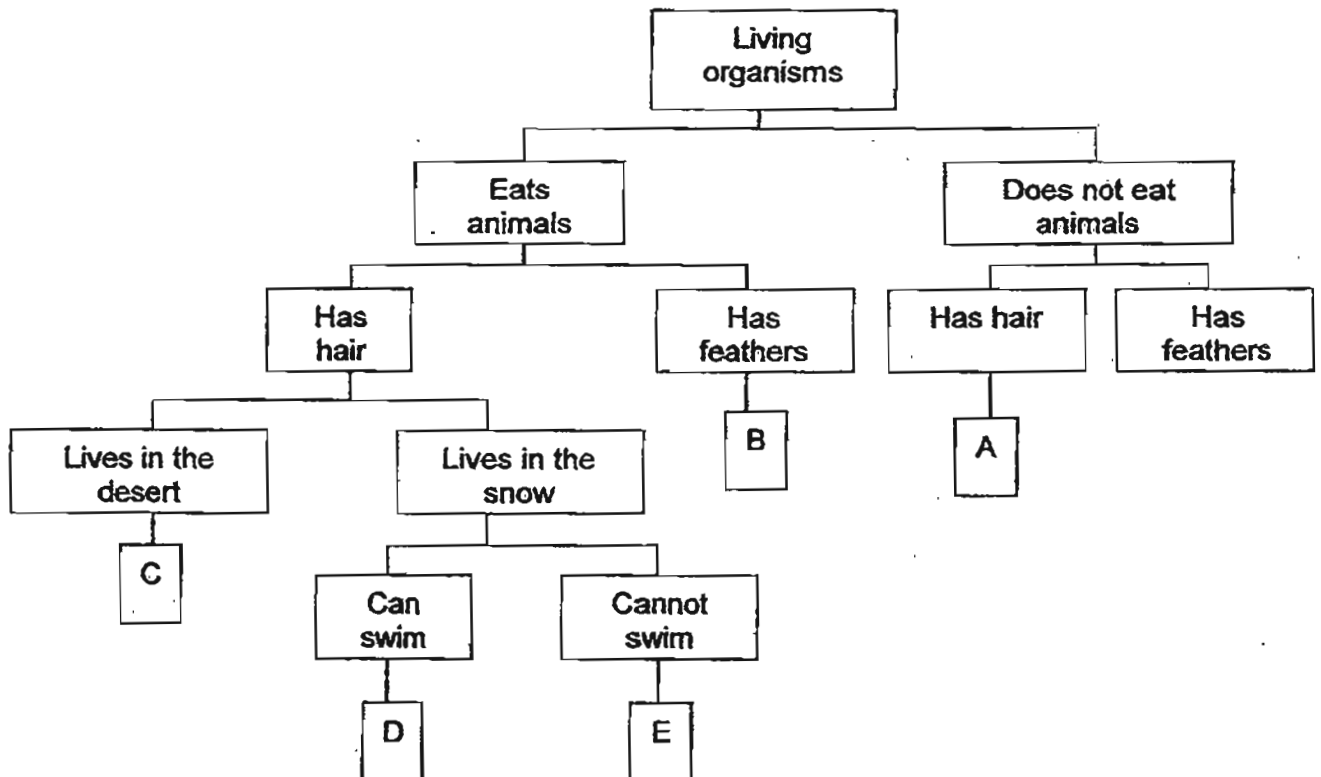

Which of the following statements is true?

- 1) B is a fish.
- 2) D only lives in water.
- 3) A and B feed on both plants and animals.
- 4) A, C and E have the same type of body covering.

24. The stem of a carnation was carefully split into two. Each half was placed in a different coloured liquid for a few days.

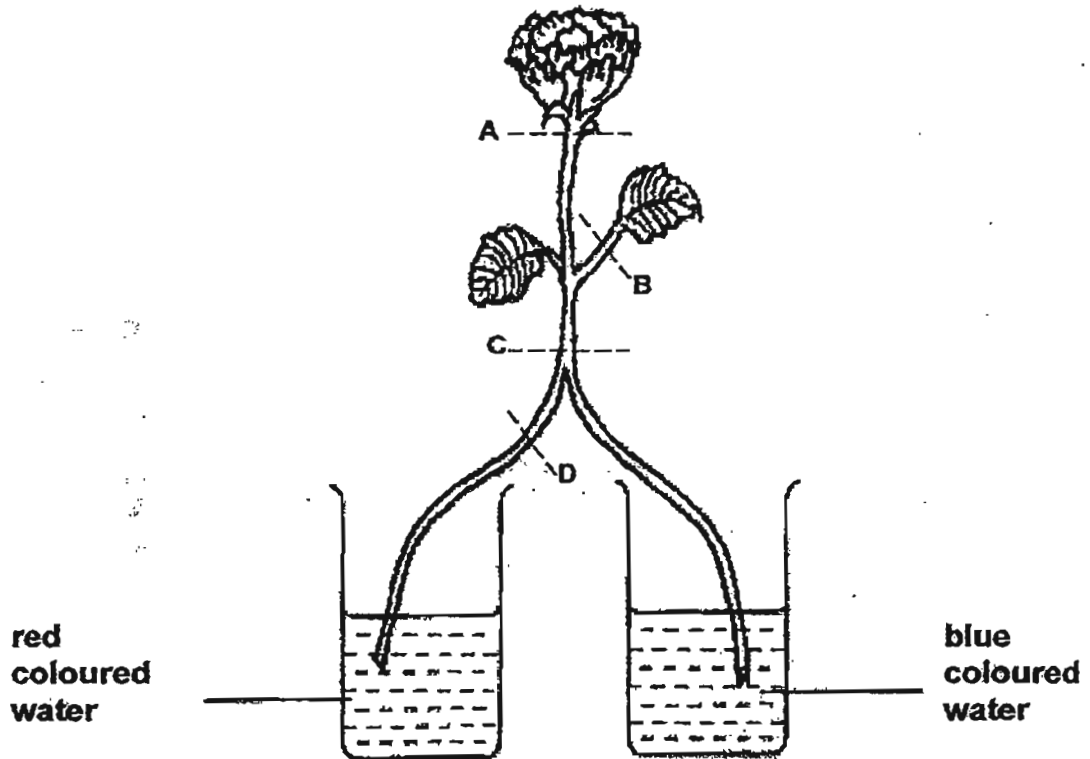

In order to see both red-stained and blue-stained tubes in the cross section of the stem, where should we cut the stem?

- (1) D only
- (2) C and D only
- (3) A, B and C only
- (4) A, B, C and D

25. The following table gives information on four plants, Q, R, S and T, based on two characteristics. A tick (✓) shows that the plant has the characteristic.

| Plant | Q | R | S | T |
|---------------|---|---|---|---|
| Bears fruit | | ✓ | | ✓ |
| Grows on land | ✓ | | | ✓ |

From the information above, where do plants R and S belong in the following classification table?

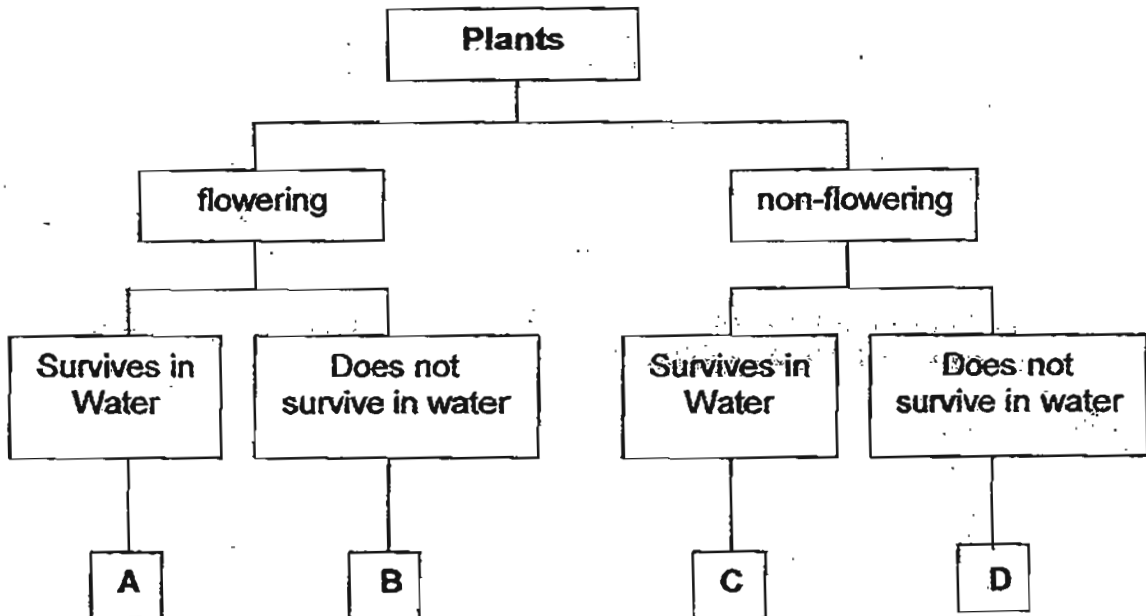

| | Plant R | Plant S |
|-----|---------|---------|
| (1) | D | A |
| (2) | C | B |
| (3) | B | D |
| (4) | A | C |

26. Yanni poured 300ml of water into each of four identical containers. She placed four Hibiscus plants, A, B, C and D, each with a different number of leaves, into the containers as shown below. A thin layer of oil was poured on the surface of the water.

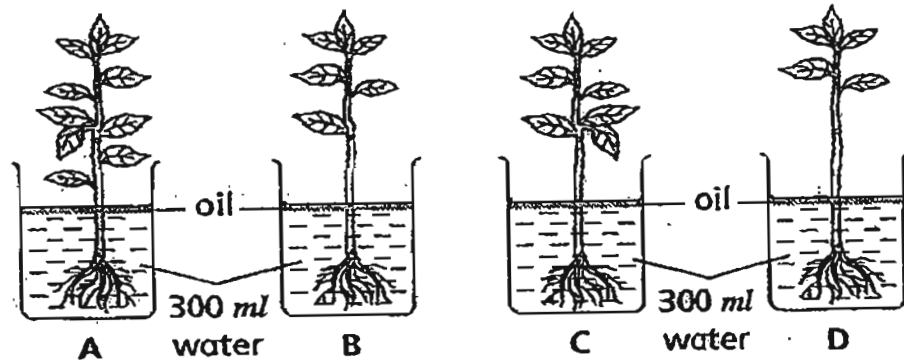

After five days, she recorded the following results.

| Plant | A | B | C | D |
|---------------------------|-----|-----|-----|-----|
| Number of leaves | 10 | 6 | 8 | 5 |
| Amount of water left (ml) | 100 | 180 | 135 | 200 |

Based only on the information above, what can Yanni conclude from the experiment?

She concludes that the _____.

- (1) greater the amount of water left, the fewer leaves the plant will grow
- (2) greater the amount of water left, the more leaves the plant will grow
- (3) more leaves the plant has, the lesser the amount of water the plant will take in
- (4) more leaves the plant has, the greater the amount of water the plant will take in

27. The table below shows the characteristics of Plants P, Q, R and S. A tick (✓) means that the plant has the characteristic.

| Plant | Characteristic | | | |
|-------|-----------------|----------------------|----------------|---------------|
| | Has a weak stem | Reproduces by spores | Found in water | Bears flowers |
| P | ✓ | | | ✓ |
| Q | | ✓ | | |
| R | ✓ | | ✓ | ✓ |
| S | ✓ | ✓ | | |

Which characteristic separates Plant R from Plants P, Q and S?

- (1) Where it grows
- (2) How it reproduces
- (3) Whether it bears flowers or not
- (4) Whether it has a strong or weak stem

28. Study the two groups of animals below.

| Group X | Group Y |
|---------|---------|
| Owl | Whale |
| Goose | Guppy |
| Penguin | Seal |

Which one of the following sets of headings is **suitable** for Group X and Group Y?

| | Group X | Group Y |
|-----|-----------------------|--|
| (1) | Birds | Mammals |
| (2) | Mammals | Fish |
| (3) | Animals that fly | Animals that swim |
| (4) | Animals that lay eggs | Animals that give birth to their young alive |

29. Study the 4-staged life cycle below.

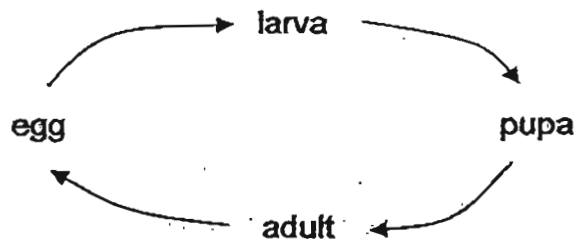

Which of the following pairs of insects **do not** go through the life cycle as shown above?

- A Cockroach
- B Mealworm beetle
- C Grasshopper
- D Mosquito

- (1) A and C
- (2) A and D
- (3) B and C
- (4) B and D

30. Five bar magnets with their ends marked A to J can be arranged as shown below.

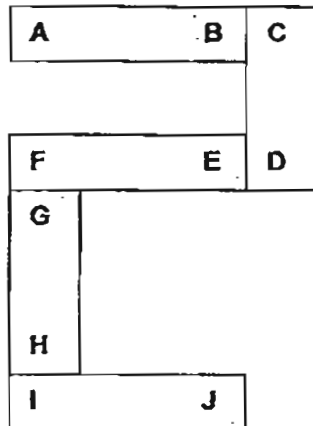

Which one of the following diagrams shows a possible arrangement of 2 magnets from the above arrangement?

(1)

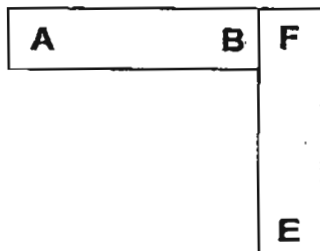

(2)

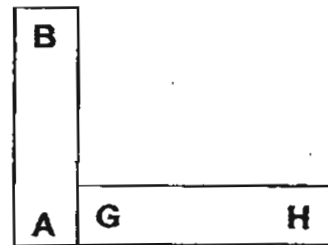

(3)

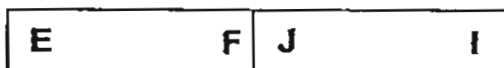

(4)

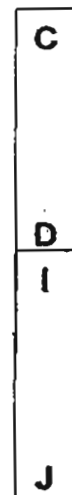

Name: _____ ()

Class P4 ()

Section B: 40 marks

Read the questions carefully and write down your answers in the spaces provided.

31. Kate sees **only** a candle flame at a corner when she enters a completely dark room.

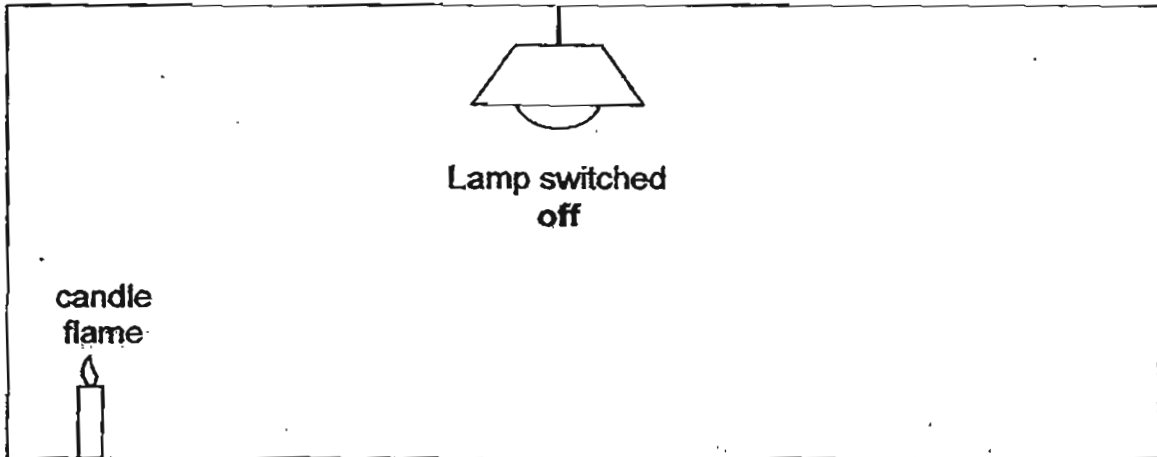

(a) Kate can see the candle flame because it _____ light. [1]

When she switches on the light in the room, she sees both the candle flame and object P.

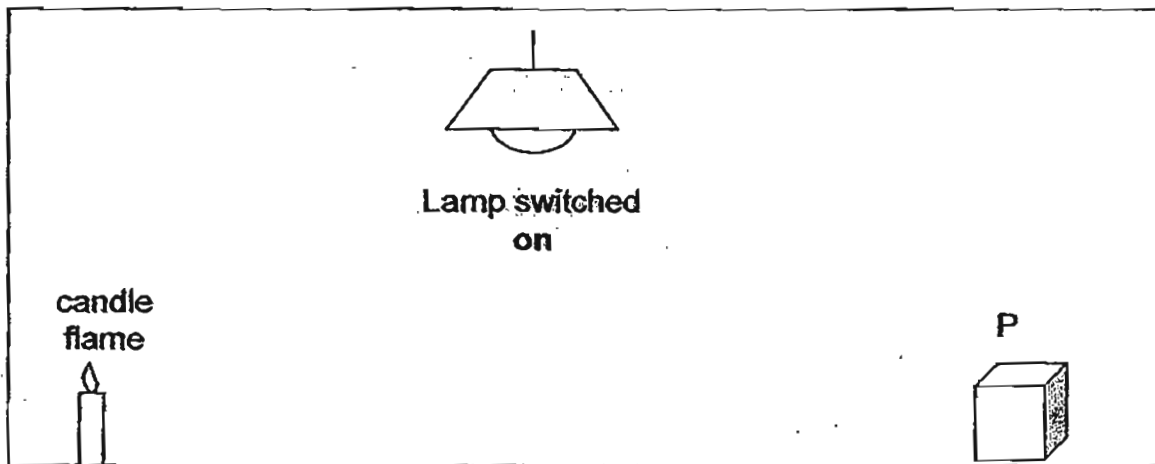

(b) Kate can see object P because it _____ light from the lamp. [1]

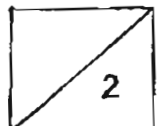

32. Mike places a metal spoon in a tub of frozen yogurt.

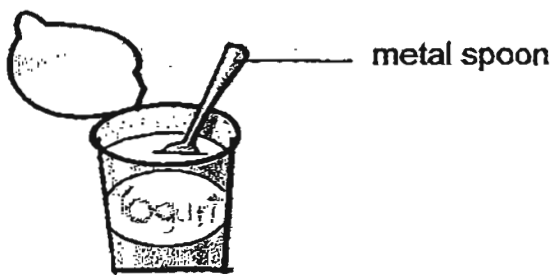

a tub of frozen yogurt

The spoon becomes colder after a while.

- (a) The metal spoon _____ heat to the frozen yogurt. [1]
- (b) The frozen yogurt gains heat from the _____. [1]

33. The diagram below shows a beaker of water.

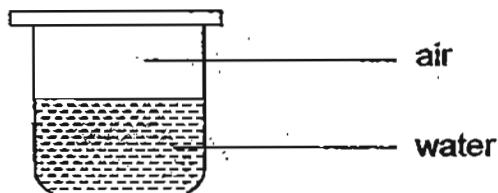

Complete the sentences to state if the parts are solid, liquid or gas.

- (a) Water is a _____. [1]
- (b) Air is a _____. [1]

34. Nicholas saw some living and non-living things in a park.

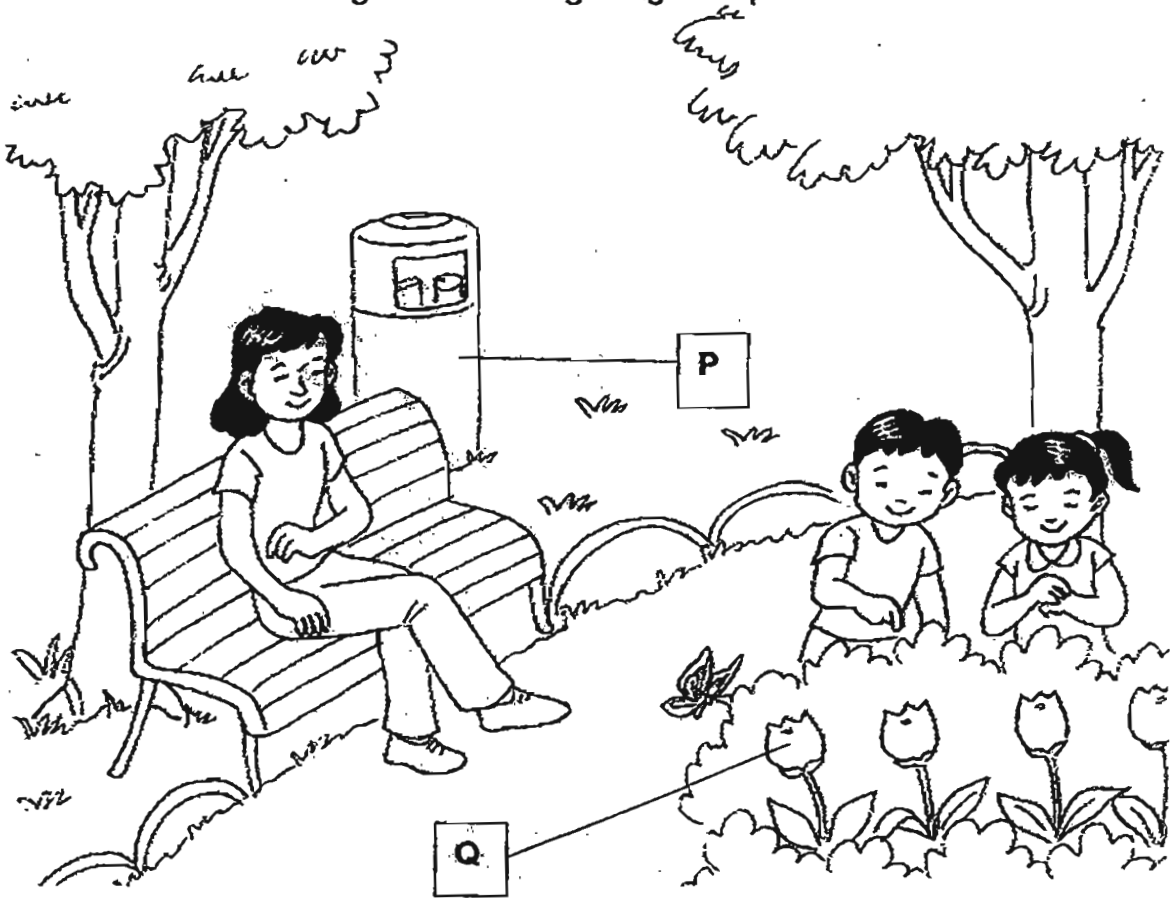

State if P and Q are living or non-living things.

(a) P is a _____.

[1]

(b) Q is a _____.

[1]

35. The diagram shows a plant.

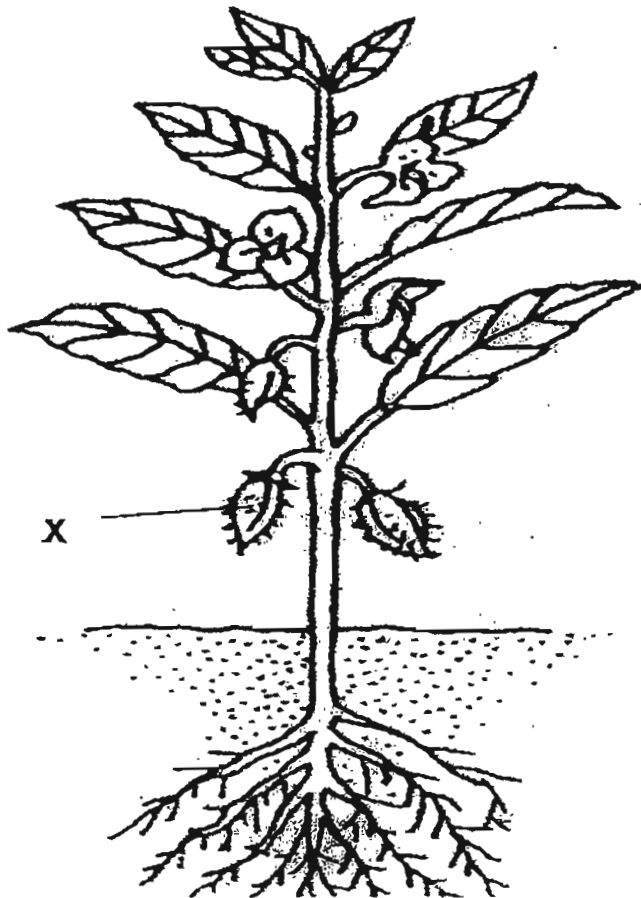

(a) What is plant part X?

X: _____

[1]

(b) Part X helps to contain and _____ the seeds.

[1]

36. Larry placed a funnel on a conical flask and quickly poured some lime water into the funnel as shown below.

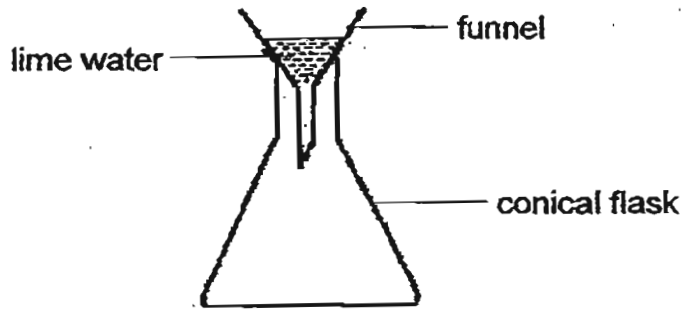

- (a) Larry observed that the lime water flowed slowly into the conical flask. Give a reason for this observation. [1]

- (b) **Without using any additional object, or breaking any part of the setup above,** what can Larry do to the setup to make the lime water flow quickly into the conical flask? [1]

- (c) Explain how your method stated in (b) allows the lime water to flow quickly into the conical flask. [1]

37. Study the classification chart below.

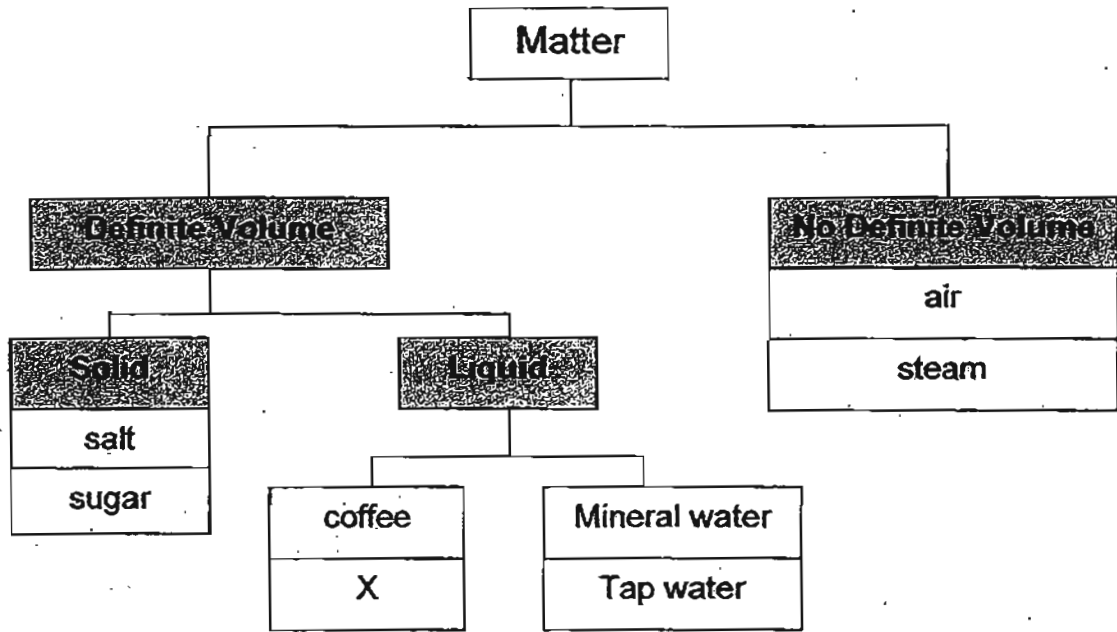

(a) Based on the classification chart above, name an item that can be placed at X. [1]

(b) Explain your answer in (a). [1]

38. John planted two plants, A and B, at a windy location as shown in the diagram below. He watered each plant with an equal amount of water and observed them every day.

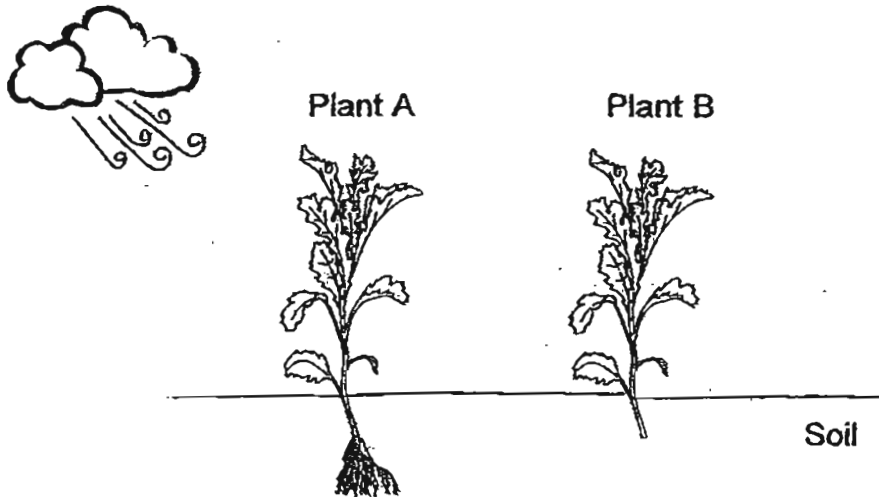

- (a) Based on the weather condition as shown in the diagram above, what difference would John observe between plant A and B after a week? [1]

- (b) Explain your answer in (a). [1]

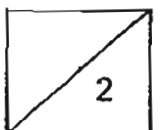

39. The organ below shows the human digestive system.

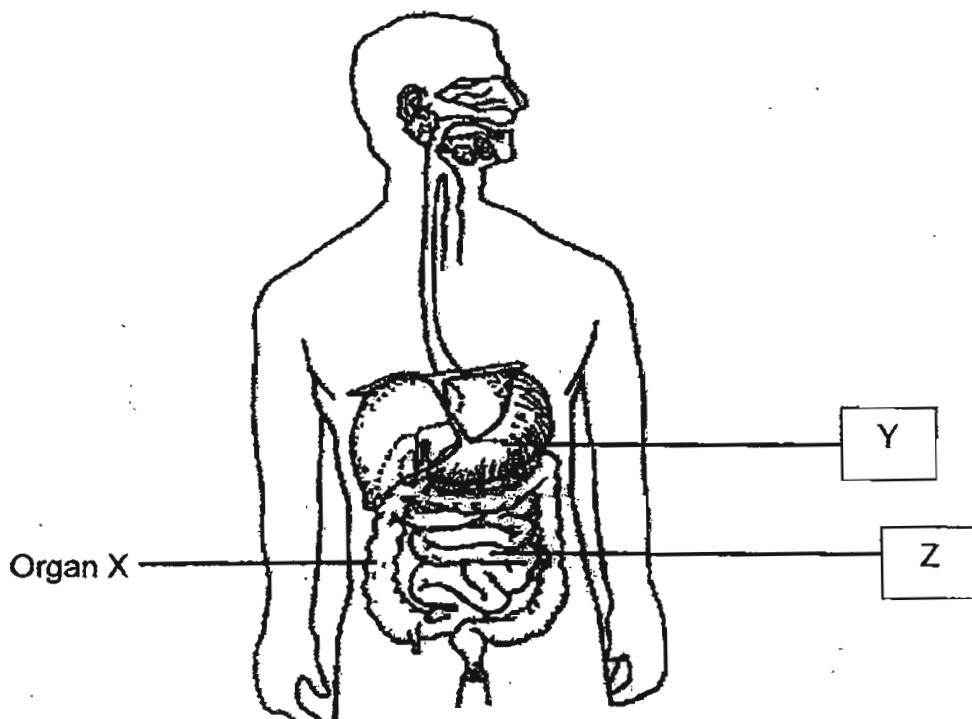

(a) Label Organs Y and Z. [2]

Organ Y: _____ Organ Z: _____

(b) What is the function of Organ Z? [1]

(c) What will happen to the undigested food in Organ X? [1]

(d) What will happen to the undigested food if it passes through Organ X too quickly? [1]

40. Yiwen carried out the experiment below by placing Object Y, which is made of opaque material, between two light sources and two screens. She then drew the shadows formed on Screen A and Screen B.

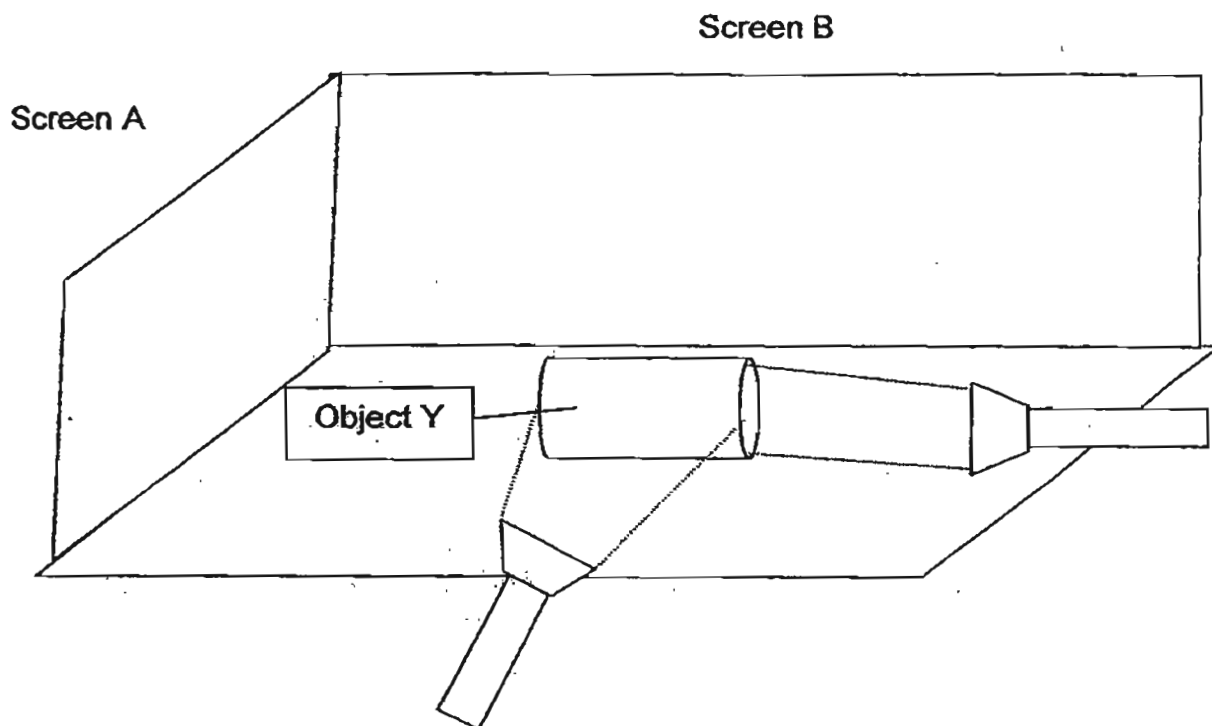

Draw the shadows that will appear on Screen A and B.

[2]

| Screen A | Screen B |
|----------|----------|
| | |

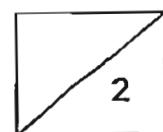

41. Danny carried out an experiment to find out which material, aluminium foil or plastic wraps, will keep his tea warm. He made tea in two metal cups using boiling water and wrapped each cup with plastic or aluminium foil as shown in the diagram below. He then used heat sensors to measure the temperature of the tea in the 2 cups every 5 minutes.

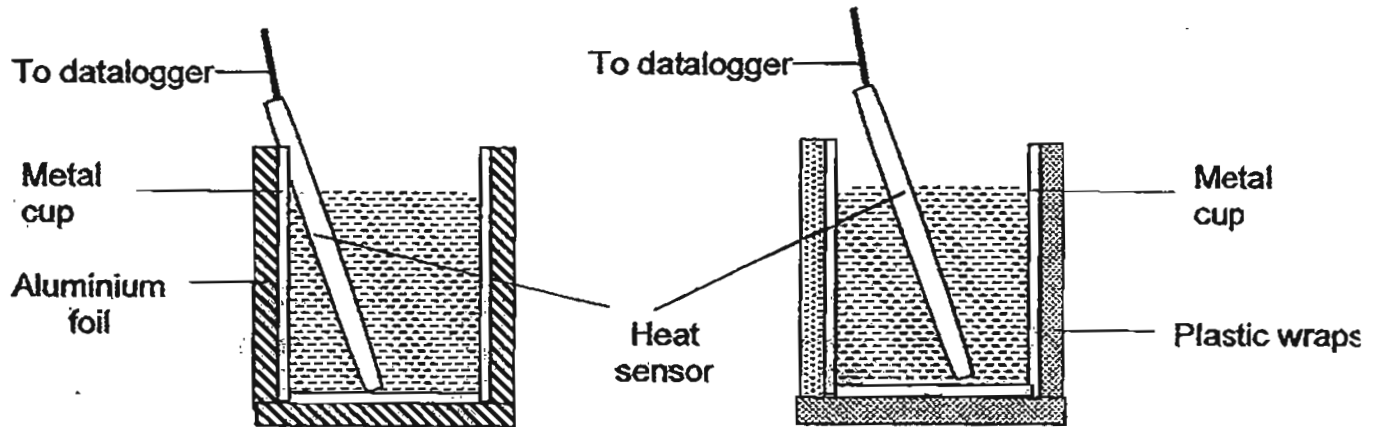

- (a) The graph below shows the change of temperature in 30 minutes. In the graph below, write 'aluminium foil' or 'plastic wraps' in the boxes. [1]

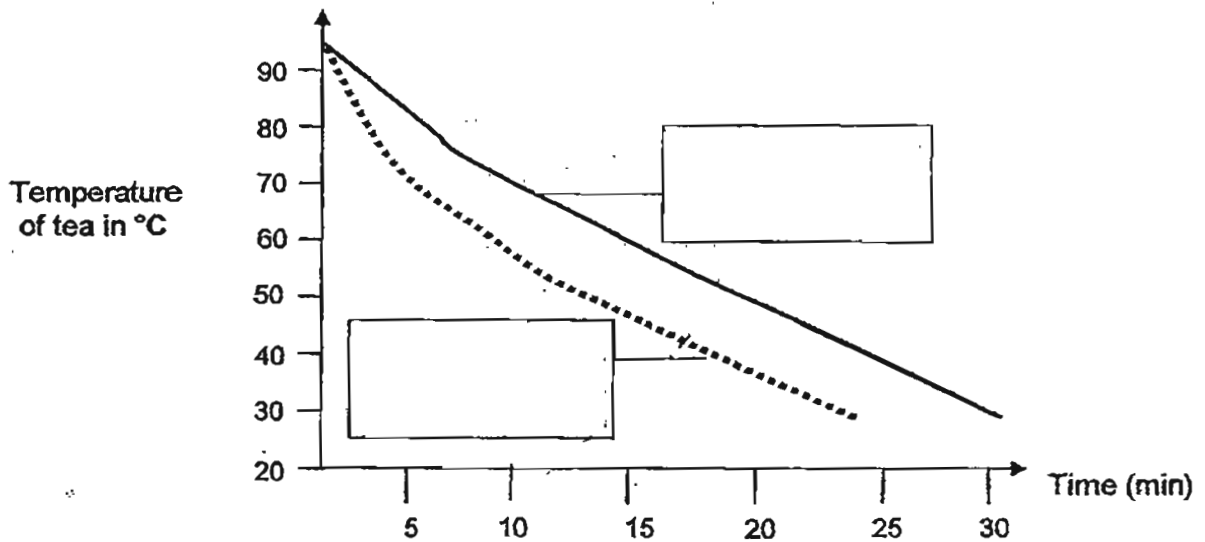

- (b) Explain your answer in (a). [1]

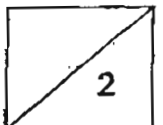

42. Ricky planted 3 green bean seeds each in Containers A and B. He placed Container A in a dark cupboard and Container B near a window and gave each pot the same amount of water every day.

By the end of Week 1, he observed that the green bean seeds in both containers had grown into young plants. He recorded the height of the 3 young plants in each container at the end of every week, as shown below.

| | In a dark cupboard | | | Near a window | | |
|------|--------------------------------------|---------|---------|--------------------------------------|---------|---------|
| | Height of plants in Container A (cm) | | | Height of plants in Container B (cm) | | |
| Week | Plant 1 | Plant 2 | Plant 3 | Plant 1 | Plant 2 | Plant 3 |
| 1 | 0.6 | 0.5 | 0.3 | 0.4 | 0.2 | 0.4 |
| 2 | 0.7 | 0.6 | 0.5 | 0.6 | 0.3 | 0.7 |
| 3 | 1.0 | 1.3 | 1.1 | 1.0 | 0.9 | 1.3 |
| 4 | 1.2 | 1.4 | 1.1 | 2.2 | 2.3 | 2.4 |
| 5 | 1.2 | 1.4 | 1.1 | 3.8 | 3.5 | 3.9 |

- (a) Based on the results above, from Week 1 to Week 3, the seeds in Containers A and B had germinated and grown in height. Explain why.

[1]

- (b) By the end of week 3, the seed leaves of the plants in Containers A and B have dropped off. Based on this observation, why did the height of the young plants in Container A remain the same after Week 4, while the height of the young plants in Container B keeps increasing?

[2]

- (c) Ricky continued to observe the young plants in Containers A and B for several more weeks. What would happen to the plants in each container?

[2]

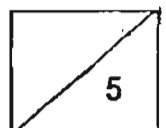

43(a). In the diagram below, label the stages in the life cycle of the mealworm beetle. [2]

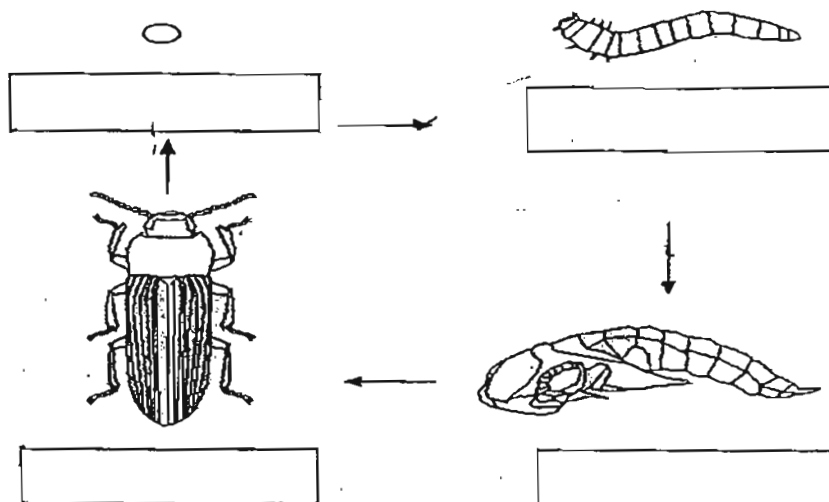

(b) The mealworm beetle is considered a pest during two stages of its life cycle. Which two stages are those? [1]

(c)

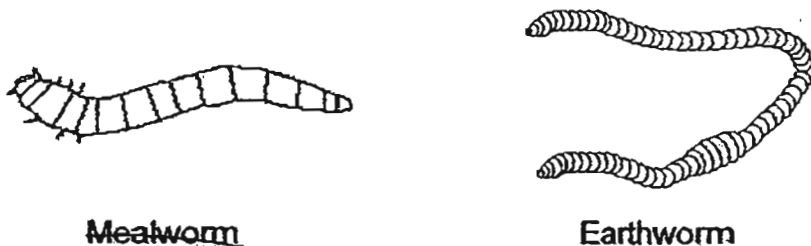

Based on the diagram above, write down one similarity and one difference between the mealworm and the earthworm. (Do not compare size or length.) [2]

Similarity:

Difference:

44. Andy conducted an experiment to find out if the magnetic strength of a bar magnet increases with its size. He hung all the four magnets, A, B, C and D, at the same distance away from a tray of evenly spread nails.

The result of his experiment is shown below.

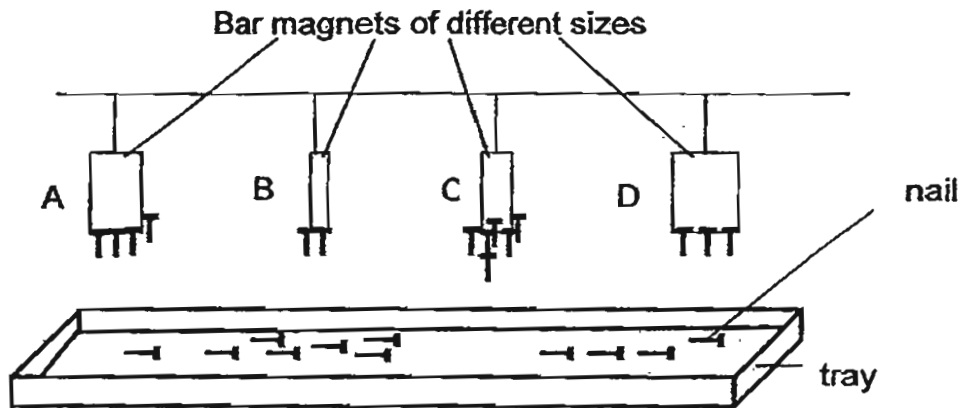

- (a) What conclusion could Andy draw based on his result? [1]
-
-
- (b) Andy wants to find out if the distance from the tray of evenly spread nails will affect the magnetic strength of the bar magnet. How should he modify his experiment? [2]
-
-
- (c) Andy wrapped the magnets, A, B, C and D, shown in the diagram above with aluminium foil. Will the experiment still work? Explain why. [1]
-
-

End of Paper

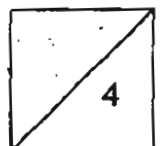

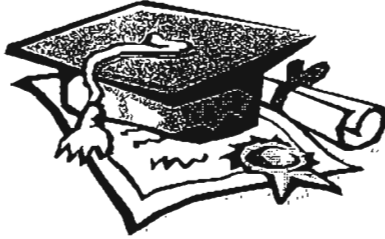

ANSWER SHEET

EXAM PAPER 2011

**SCHOOL : AITONG
SUBJECT : PRIMARY 4 SCIENCE**

TERM : SA2

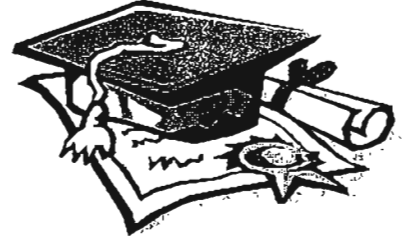

| | | | | | | | | | | | | | | | | |
|----|----|----|----|----|----|----|----|----|-----|-----|-----|-----|-----|-----|-----|-----|
| Q1 | Q2 | Q3 | Q4 | Q5 | Q6 | Q7 | Q8 | Q9 | Q10 | Q11 | Q12 | Q13 | Q14 | Q15 | Q16 | Q17 |
| 3 | 2 | 4 | 4 | 4 | 1 | 3 | 2 | 4 | 1 | 1 | 3 | 3 | 4 | 2 | 4 | 1 |

| | | | | | | | | | | | | |
|-----|-----|-----|-----|-----|-----|-----|-----|-----|-----|-----|-----|-----|
| Q18 | Q19 | Q20 | Q21 | Q22 | Q23 | Q24 | Q25 | Q26 | Q27 | Q28 | Q29 | Q30 |
| 2 | 4 | 3 | 3 | 2 | 4 | 3 | 4 | 4 | 1 | 4 | 1 | 4 |

31)a)gives out b)reflects

32)a)loss b)metal spoon

33)a)liquid b)gas

34)a)non-living thing b)living thing

35)a)X: fruit b)protect

36)a)There is no hole in or gap for the air in the conical flask to escape thus flowed slowly into the conical flask so air takes up space.

b)He can lift up the funnel.

c)Lifting up the funnel allows air to escape from the flask thus allowing water to go in to take up the space.

37)a)Milo

b)Milo has a definite volume, is a liquid and is opaque, not allowing any light to pass through.

38)a)Plant A would remain standing upright and rooted to the soil.

b)Plant A has roots, thus the roots hold the plant firmly to the ground. However, plant B does not have roots to hold it firmly to the ground, thus it get over from the soil by the wind.

39)a)Y: stomach Z: small intestine

b)It is to digestion of food and to absorb the digested food into the bloodstream.

c)Water would be absorbed by the large intestine.

d)It will not be able to absorb the water of the undigested food and thus the solid waste that comes out from the anus would be watery.

40) Screen A



Screen B

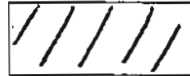

41)a) _____ Plastic wraps
_____ Aluminium foil

b) Aluminium foil is a better conductor of heat thus it conducts heat from the tea faster, but the plastic wrap is a poor conductor of heat thus conducting heat from the tea slower.

42)a) A seed only needs air, water and warmth to germinate, it does not need sunlight and all the seeds had the 3 conditions.

b) The plants dropped off their seed leaves and grew leaves, thus they need sunlight to make food. However, the young plants in container A does not have any sunlight to make food,

c) The young plants in container A would die while the young plants in container B would grow taller.

43)a) egg → larva

adult ← pupa

b) larva and adult stage

c) Similarity: Both have many body segments.

Difference: A Mealworm has legs while an earthworm does not.

44)a) The magnetic strength of a bar magnet does not depend on its size.

b) He should use magnets of the same size and strength and make the distance between the magnet and the tray different.

c) Yes. Aluminium foil is not a magnetic material thus magnetism can be passed through.