



**NAN HUA PRIMARY SCHOOL
SEMESTRAL ASSESSMENT 1 – 2019
PRIMARY 4**

SCIENCE

BOOKLET A

28 Multiple Choice Questions (56 marks)

Total Time for Booklets A and B: 1 hour 45 minutes

INSTRUCTIONS TO CANDIDATES

1. Write your name and index number in the space provided.
2. Do not turn over the page until you are told to do so.
3. Follow all instructions carefully.
4. Answer all questions.
5. Shade your answers in the Optical Answer Sheet (OAS) provided.

Marks Obtained

| | | |
|-----------|--|------|
| Booklet A | | /56 |
| Booklet B | | /44 |
| Total | | /100 |

Name: _____ () Class: P 4 _____

Date : 15 May 2019

Parent's signature:

Section A: (28 x 2 marks = 56 marks)

For each question from 1 to 28, four options are given. One of them is the correct answer. Make your choice (1, 2, 3 or 4) and shade the correct oval on the Optical Answer Sheet.

1. Which of the following is a source of light?



(1)



tree

(2)

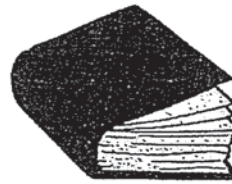

book

(3)

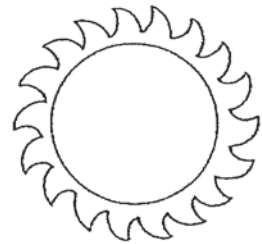

sun

(4)

2. Wei Sheng conducted an experiment in a dark room using the set-up below.

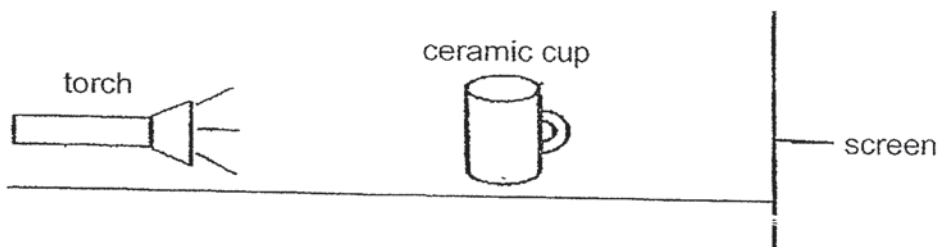

Which of the following shadows could be seen on the screen?

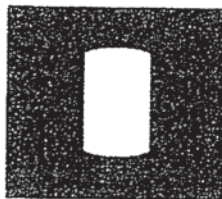

(1)



(2)

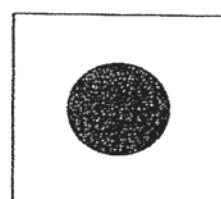

(3)

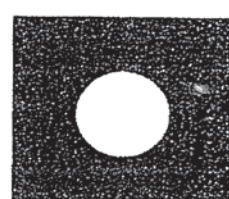

(4)

3. Mary walked from point A to C, passing by a lamp post at point B. She realised that the length of her shadow changed as she walked from A to C.

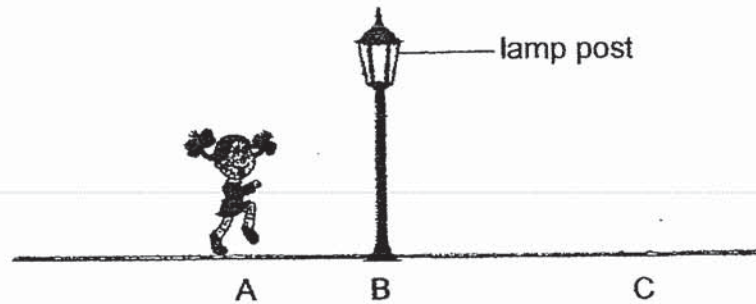

Which of the following statements is **not** correct?

- (1) Her shadow at C is the longest.
 - (2) Her shadow at B is the longest.
 - (3) The length of her shadow increases as she walks from B to C.
 - (4) The length of her shadow decreases as she walks towards the lamp post.
4. Which of the following is **not** matter?
- (1) wind
 - (2) sand
 - (3) water
 - (4) shadow

5. The diagram below shows the alphabet balloons from Janet's birthday party. This is an example to show that the air in the balloons has _____.

**HAPPY
BIRTHDAY**

- (1) a definite shape
- (2) a definite volume
- (3) no definite shape
- (4) no definite volume

6. Study the classification chart below.

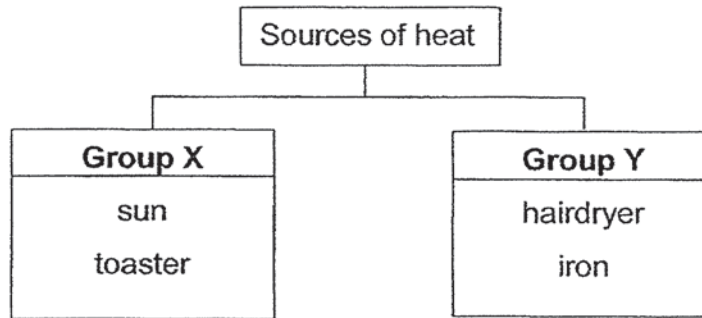

Which of the following sources of heat is wrongly classified?

- (1) sun
 - (2) iron
 - (3) toaster
 - (4) hairdryer
7. Mrs John could not open the metal lid of a jar as shown in the diagram below.



Her children gave her the following suggestions to open the lid easily.
Which of the following suggestions is **not** correct?

- (1) Put the jar in the refrigerator.
- (2) Run hot running water on the lid.
- (3) Use a candle flame to heat the lid.
- (4) Use a hairdryer and blow some hot air onto the lid.

8. The diagram below shows a kettle.

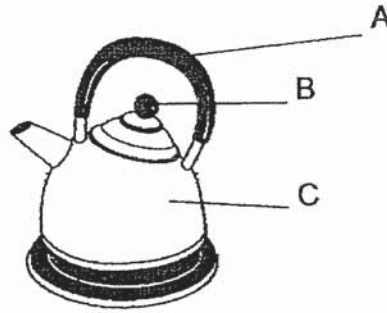

Which parts of the kettle, A, B and/or C, are made of materials which are poor conductors of heat?

- (1) A and B only
(2) A and C only
(3) B and C only
(4) A, B and C
9. Which of the following spoons will break into pieces when it is dropped onto the floor?
- (1) steel spoon
(2) plastic spoon
(3) ceramic spoon
(4) wooden spoon
10. Four bars, A, B, C and D, were hung with four identical strings from a piece of wooden rod. The bars were found in different positions as shown below. Only two of the bars are magnets.

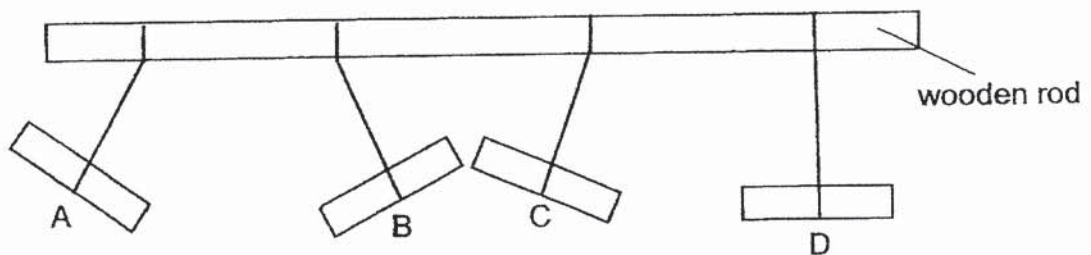

Which of the two bars are magnets?

- (1) A and B
(2) A and D
(3) B and C
(4) C and D

- 11 Mr Ong coiled an electrical wire around an iron nail as shown in the diagram below. The iron nail attracted a few paper clips.

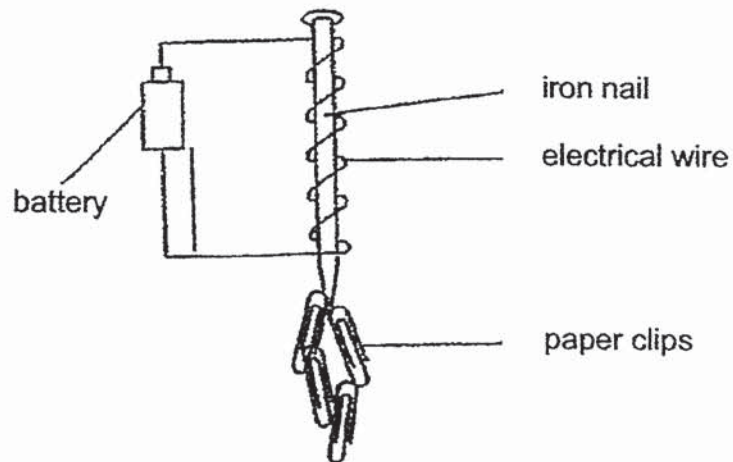

What could Mr Ong do if he wants more paper clips to be attracted to the iron nail?

- A Add a switch to the set-up
 - B Add more batteries to the set-up
 - C Replace the iron nail with a plastic rod
 - D Add more coils of wire around the iron nail
- (1) A and B only
(2) A and C only
(3) B and D only
(4) C and D only

12. Amy wanted to find out the amount of light that could pass through four different materials, A, B, C and D. She set up an experiment as shown in the diagram below.

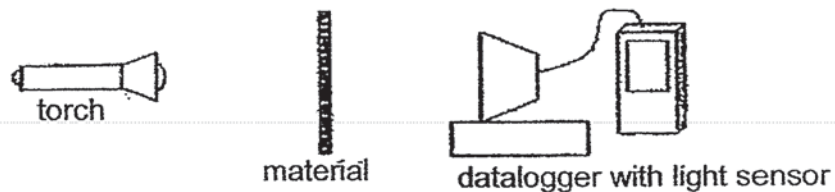

She recorded her findings in a bar graph as shown below.

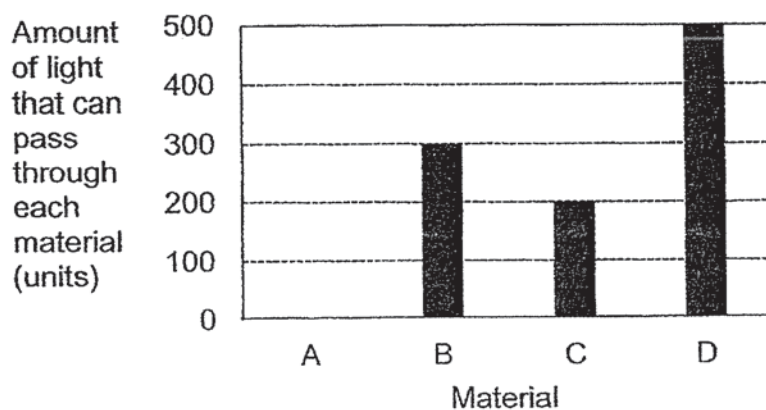

Based on the bar graph above, which of the following statements is correct?

- (1) Material A allows most light to pass through.
- (2) Material D does not allow light to pass through.
- (3) Material B allows more light to pass through than Material C.
- (4) Material C allows more light to pass through than Material D.

13. Sam placed a metal object at position Q, in between a torch and a screen, as shown in the diagram below.

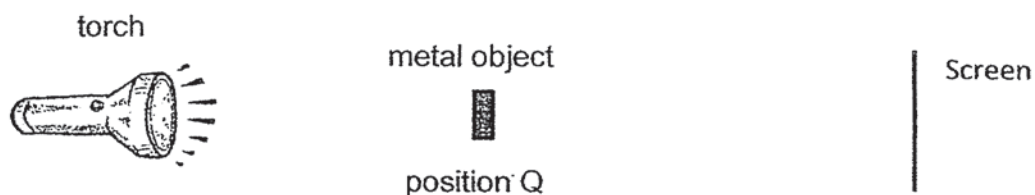

He then moved the object to two different positions, P and R, without moving the torch and the screen, as shown in the diagram below.

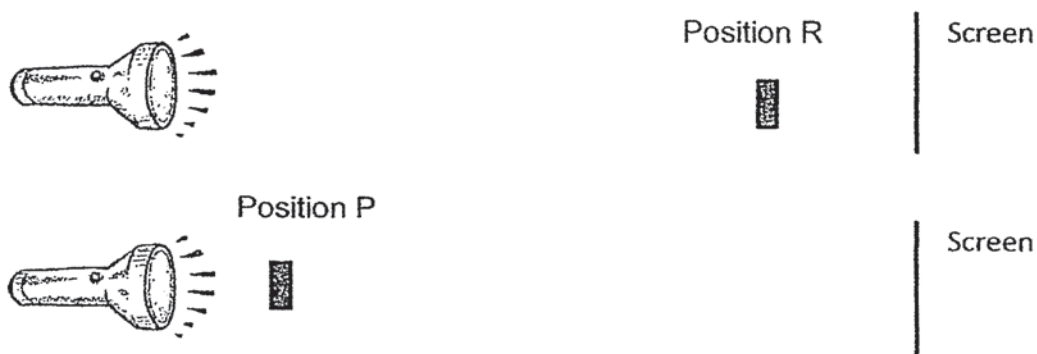

Sam measured the length of the shadow of the object formed on the screen from the three positions, P, Q and R, and recorded the lengths of the shadow in the table below.

| Position | Length of shadow (cm) |
|----------|-----------------------|
| P | x |
| Q | 25 |
| R | y |

What are the possible length of shadows at positions P and R?

| | X (cm) | Y (cm) |
|-----|--------|--------|
| (1) | 8 | 20 |
| (2) | 10 | 48 |
| (3) | 25 | 19 |
| (4) | 36 | 13 |

14. Wati wanted to find out the volume of object Z. She was given the following apparatus to carry out her experiment.



She came up with the following steps to carry out her experiment.

- A Calculate the increase in volume.
- B Record the total volume of water and object Z.
- C Pour 20 ml of water into the measuring cylinder.
- D Tie a string around object Z and lower the object into the water in the measuring cylinder.

Which of the following shows the correct order of steps she should take?

- (1) C, A, D, B
 - (2) C, D, B, A
 - (3) D, C, A, B
 - (4) D, B, C, A
15. Cynthia put a packet of tea into a cup as shown in the diagram below.

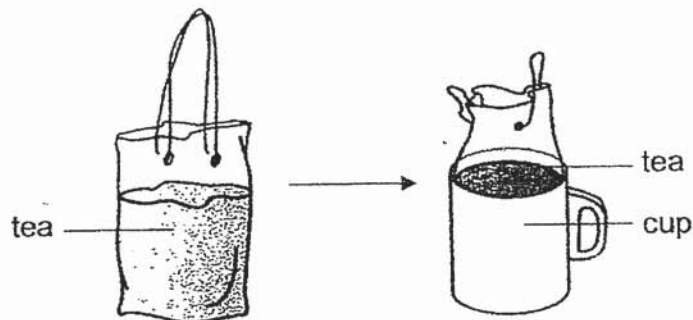

Which of the following about the packet of tea is correct?

- (1) Both the shape and volume of the tea changed.
- (2) Both the shape and volume of the tea did not change.
- (3) The shape of the tea changed but the volume did not.
- (4) The volume of the tea changed but the shape did not.

16. The conical flask below has a volume of 200 cm^3 of air.

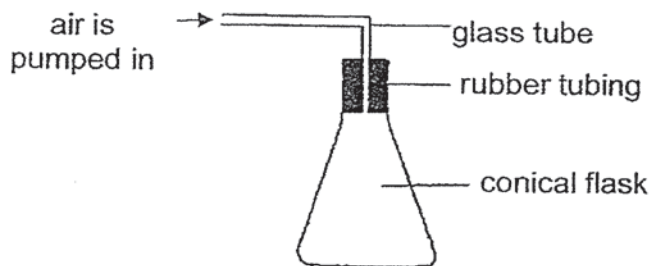

Mike pumped in another 50 cm^3 of air into the conical flask. What is the final volume of air in the flask?

- (1) 50 cm^3
 - (2) 200 cm^3
 - (3) 250 cm^3
 - (4) 300 cm^3
17. Lili filled three syringes with substances P, Q and R respectively.

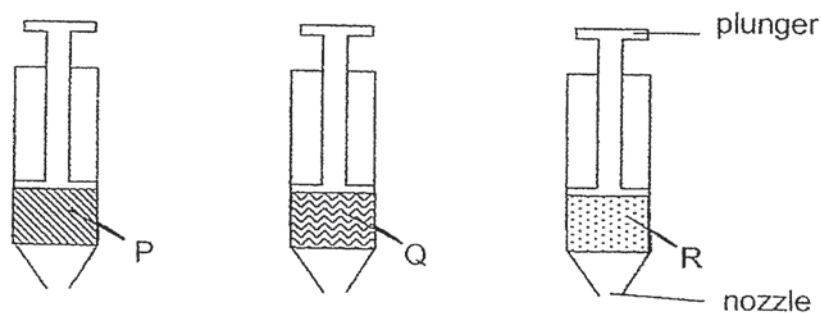

Lili sealed the nozzles of the syringes with her palm and was able to push in the plunger of the syringe containing substance R only.

Based on the above experiment, which of the following statements is correct?

- (1) Substance P has no mass.
- (2) Substance Q has no definite shape.
- (3) Substance R has no definite volume.
- (4) Substances P and Q can be compressed.

18. Mrs Chan prepared two identical beakers, X and Y, each containing a different amount of hot water at the same temperature.

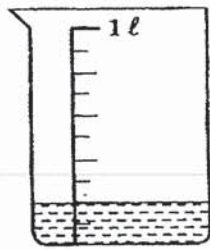

beaker X

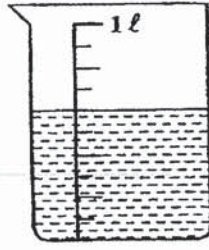

beaker Y

Which of the following graphs shows the amount of heat present in each beaker?

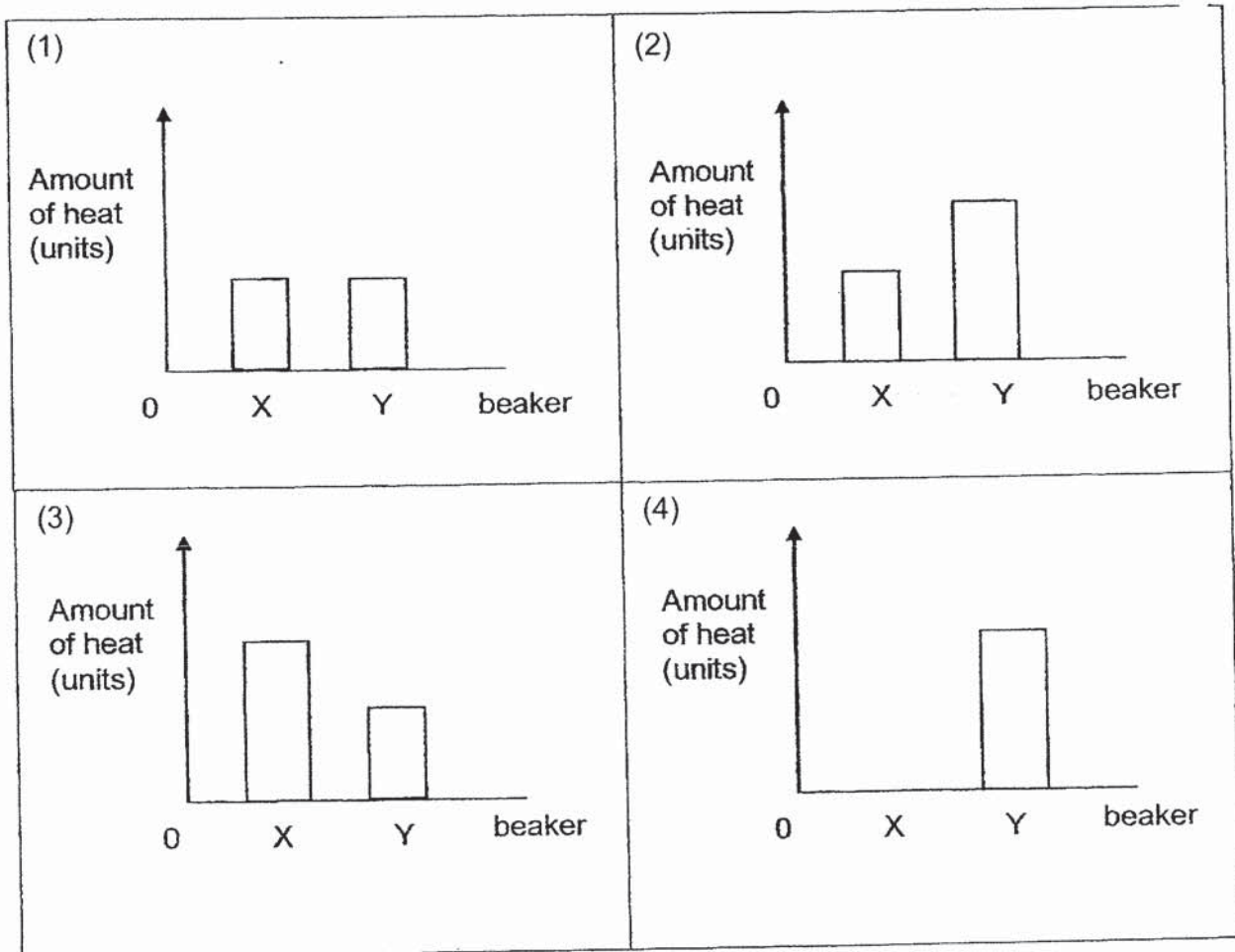

19. Sheila placed a hot metal spoon at 60°C into a beaker of tap water at 25°C as shown in the diagram below.

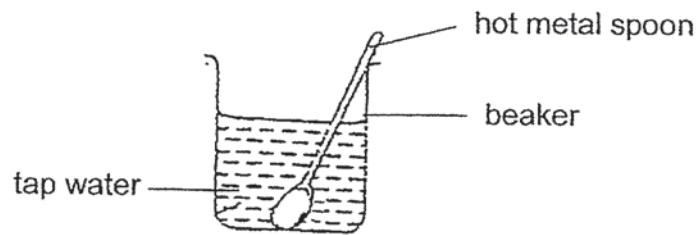

Which of the following observations are correct?

- A The temperature of the water rises.
 - B The temperature of the spoon rises.
 - C The metal spoon loses heat to the tap water.
 - D The metal spoon gains heat from the beaker.
- (1) A and C only
(2) A and D only
(3) B and C only
(4) B and D only

20. Wee Meng set up an experiment using four identical flasks. Different types of liquids, A, B, C and D, were poured into each flask. The flasks were placed in a basin of hot water as shown in the diagrams below.

After 20 minutes, Wee Meng observed that each liquid had moved up the tube to different levels.

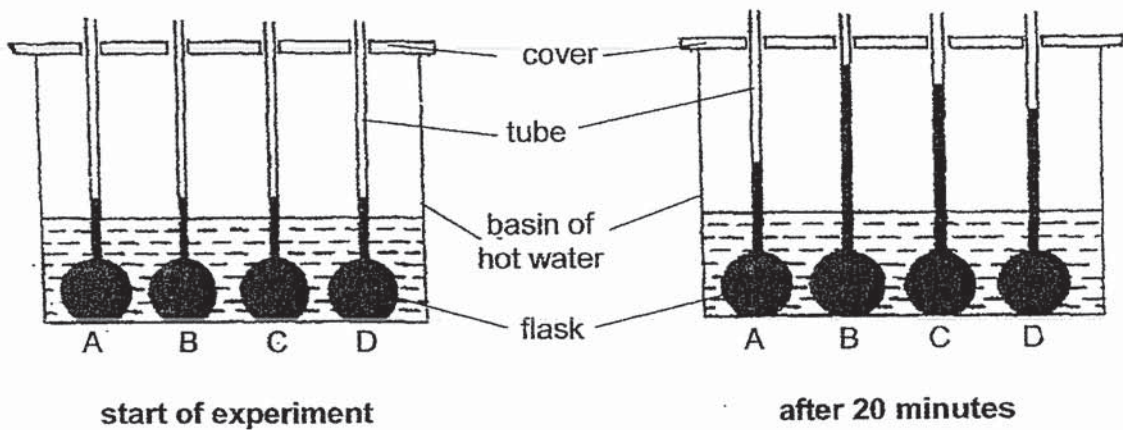

Which of the following shows the correct order at which the liquids gained heat from the hot water, starting from the liquid that gained heat the slowest to the liquid that gained heat the fastest?

- (1) A, D, C, B
- (2) B, C, D, A
- (3) C, B, A, D
- (4) D, A, B, C

21. Ali used the same amount of wax to fix four thumbtacks to the ends of four rods made of different materials, P, Q, R and, S. He heated each rod at the other end for 2 minutes as shown in the diagram below.

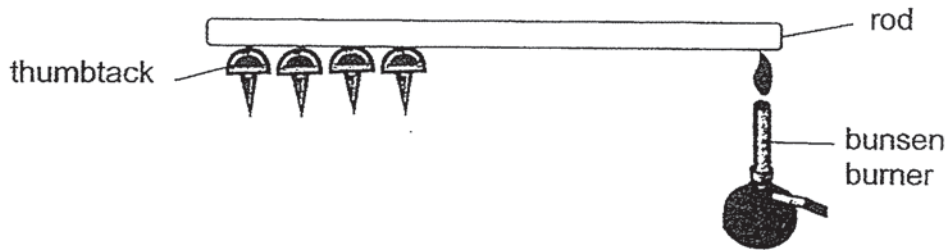

Ali recorded his observations of the thumbtacks in the table below.

| Rod | P | Q | R | S |
|--|---|---|---|---|
| Number of thumbtacks left on the rod after 2 minutes | 2 | 1 | 4 | 3 |

22. Which of the following correctly identifies the best conductor and the poorest conductor of heat?

| | Best conductor of heat | Poorest conductor of heat |
|-----|------------------------|---------------------------|
| (1) | P | S |
| (2) | Q | R |
| (3) | R | Q |
| (4) | S | P |

22. The table below shows some properties of materials A, B and C.

| Material | Is it flexible? | Does it allow light to pass through? |
|----------|-----------------|--------------------------------------|
| A | No | No |
| B | Yes | No |
| C | No | Yes |

Which of the following could materials A, B and C be respectively?

| | A | B | C |
|-----|---------|---------|---------|
| (1) | rubber | glass | ceramic |
| (2) | metal | rubber | glass |
| (3) | glass | ceramic | metal |
| (4) | ceramic | metal | rubber |

23. Sara was given four types of materials, A, B, C and D, to make a swimming float. She tested the materials and recorded her results in the table below. A tick (✓) indicates that the material has that property.

| Material | Breaks easily | Sinks in water | Waterproof |
|----------|---------------|----------------|------------|
| A | ✓ | | ✓ |
| B | ✓ | | |
| C | | | ✓ |
| D | | ✓ | ✓ |

Which material is suitable to make the swimming float?

- (1) A
 (2) B
 (3) C
 (4) D
24. Alex wanted to find out the strength of four magnets. He used four magnets, R, S, T and U, of the same size and shape to pick up some paper clips. The results are shown in the table below.

| Magnet | Number of paper clips |
|--------|-----------------------|
| R | 9 |
| S | 5 |
| T | 2 |
| U | 7 |

Which magnet is the strongest?

- (1) Magnet R
 (2) Magnet S
 (3) Magnet T
 (4) Magnet U

25. Leonard arranged three magnets such that the poles are attracted to one another as shown in the diagram below.

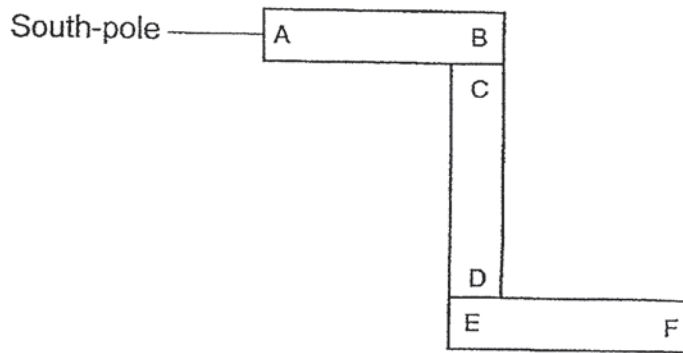

Which of the following is another possible arrangement of the three magnets?

(1)

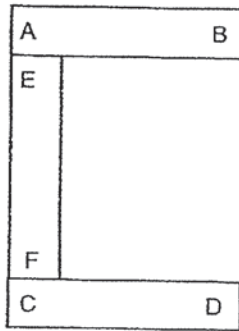

(2)

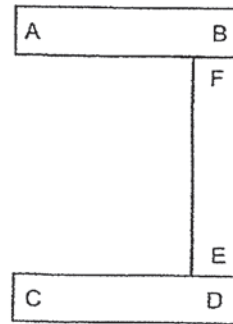

(3)

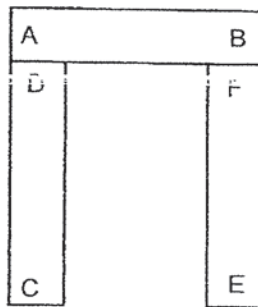

(4)

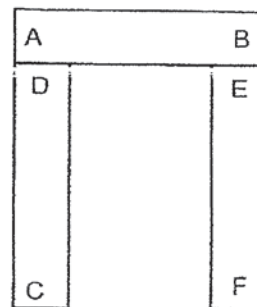

26. Study the classification chart below.

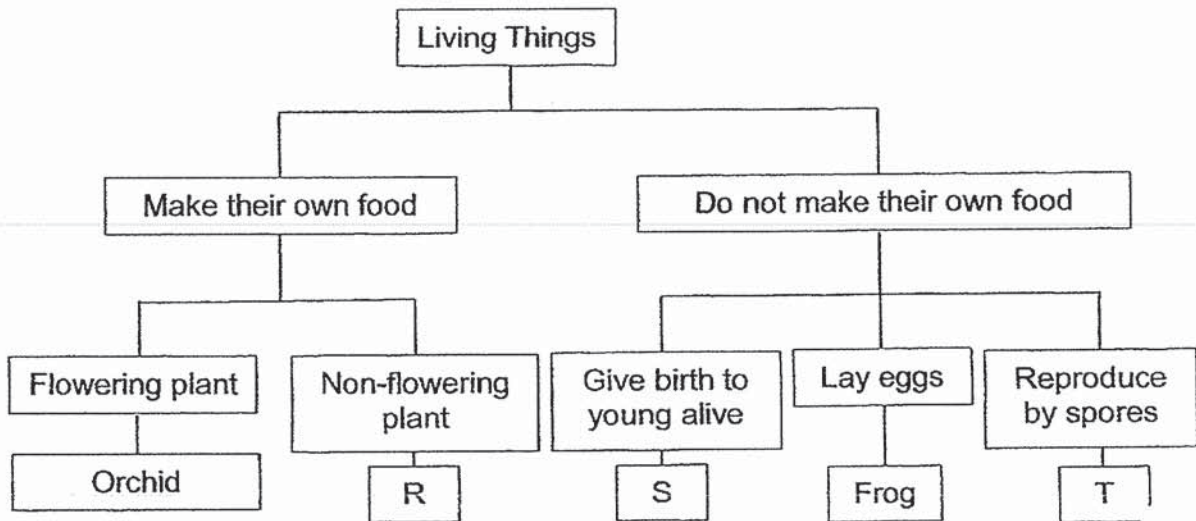

Which of the following could R, S and T be ?

| | R | S | T |
|-----|----------|----------|----------|
| (1) | fern | mushroom | rabbit |
| (2) | fern | rabbit | mushroom |
| (3) | mushroom | fern | rabbit |
| (4) | mushroom | rabbit | fern |

27. The diagrams below show a plant and an animal.



Alicia, Bella, Catty and Dora made the following comments about them.

Alicia : They are living things because they can reproduce.

Bella : They are living things because they can move from place to place.

Catty : They are non-living things because they cannot grow bigger.

Dora : They are non-living things because they do not need air, food and water to survive.

Whose statement is correct?

- (1) Alicia
- (2) Bella
- (3) Catty
- (4) Dora

28. The diagrams below show a mushroom and some bacteria.



mushroom



bacteria

Which of the following is a similarity between the mushroom and the bacteria?

- (1) They reproduce by seeds.
- (2) They can make their own food.
- (3) They do not need water to survive.
- (4) They can respond to changes in the surroundings.

End of Booklet A



NAN HUA PRIMARY SCHOOL
SEMESTRAL ASSESSMENT 1 – 2019
PRIMARY 4

SCIENCE

BOOKLET B

12 Open-ended questions (44 marks)

Total Time for Booklets A and B: 1 hour 45 minutes

INSTRUCTIONS TO CANDIDATES

1. Write your name and index number in the space provided.
2. Do not turn over the page until you are told to do so.
3. Follow all instructions carefully.
4. Answer all questions.
5. Write your answers in this booklet.

Marks Obtained

Section B

| | |
|--|------|
| | / 44 |
|--|------|

Name: _____ () Class: P 4 _____

Date: 15 May 2019

Parent's Signature: _____

Section B: (44 marks)

Write your answers to questions 29 to 40.

The number of marks available is shown in brackets [] at the end of each question or part question.

29. In a brightly-lit room, Mr Quek is able to see the dog from the mirror.

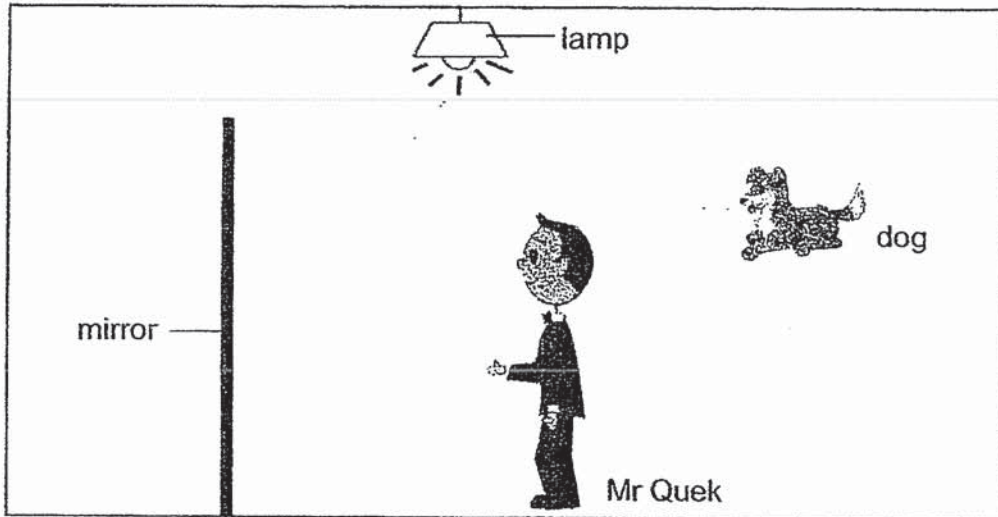

(a) State two properties of light which enable Mr Quek to see the dog from the mirror. [2]

- (i) _____
- (ii) _____

(b) The moon is not a source of light. Explain why we are able to see the moon at night. [1]

(c) State one example of a natural light source. [1]

| | |
|-------|---|
| Score | 4 |
|-------|---|

30. Kevin poured 50 cm^3 of water into a measuring cylinder as shown in the diagram below. He then poured the 50 cm^3 of water from the measuring cylinder into the conical flask.

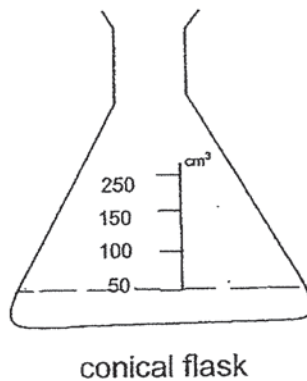
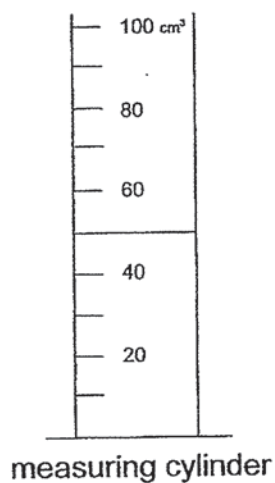

- (a) Draw the water level in the conical flask. [1]
- (b) State two properties of water as shown in the diagram above. [2]

| | |
|-------|----|
| Score | / |
| | -3 |

31. Siti wants to find out how time affects the temperature of boiling water.

The graph below shows the temperature of a cup of boiling water after it was left on the table for 40 minutes.

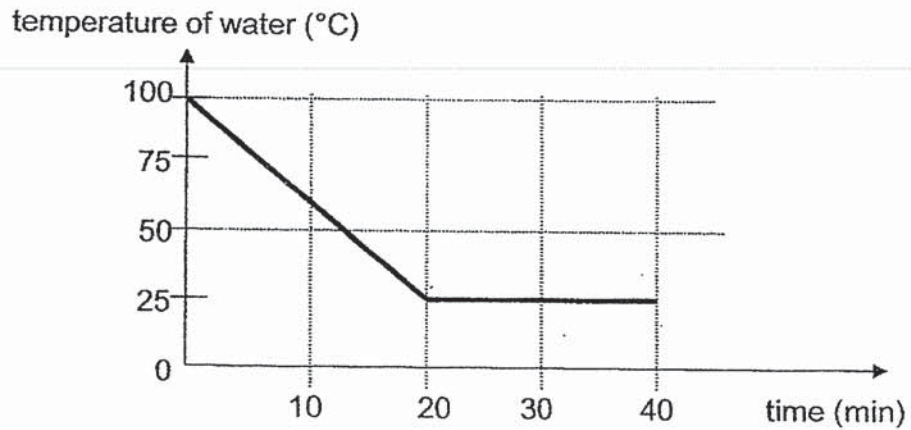

- (a) Identify the dependent variable (measured variable) in this experiment. [1]

- (b) Explain the change in temperature of the boiling water for the first 20 minutes of the experiment. [2]

- (c) Why did the temperature of the water remain constant after 20 minutes? [1]

| | |
|-------|---|
| Score | 4 |
|-------|---|

32. Mindy had three objects, A, B and C, which were wrapped with black paper. She used a bar magnet to find out what would happen when one end of each object was brought close to the north-pole of the bar magnet.



She recorded her observations in the table below.

| Object | Observation |
|--------|----------------------------|
| A | moved towards the magnet |
| B | no movement |
| C | moved away from the magnet |

- (a) Based on the above observations, put a tick (✓) in the correct box to indicate if each statement is 'correct', 'incorrect' or 'not possible to tell'. [3]

| | Statement | Correct | Incorrect | Not possible to tell |
|-------|--------------------------------------|---------|-----------|----------------------|
| (i) | Object A is a non-magnetic material. | | | |
| (ii) | Object B is made of plastic. | | | |
| (iii) | Object C is a magnet. | | | |

Mindy took a thread and hung the bar magnet freely as shown below. The magnet pointed to a direction after it came to a rest.

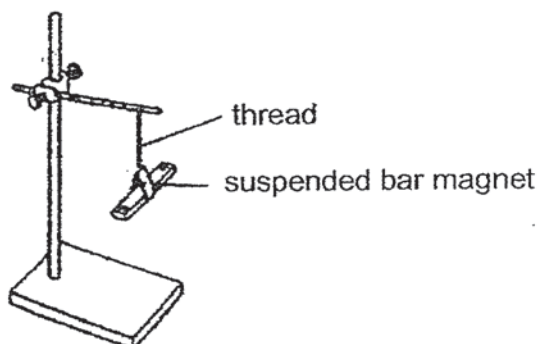

- (b) In which direction would the bar magnet point to when it came to a rest? [1]

| | |
|-------|---|
| Score | 4 |
|-------|---|

33. Sally used the set-up below to conduct an experiment.

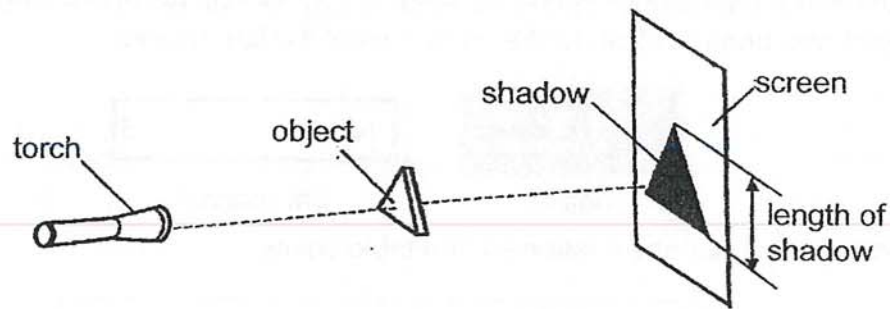

She changed the position of the torch in the set-up and recorded her observations as shown in the table below.

| Attempt | Length of shadow (cm) |
|-----------------|-----------------------|
| 1 st | 7 |
| 2 nd | 9 |
| 3 rd | 14 |
| 4 th | 17 |

(a) Based on the results, how was the position of the torch changed after each attempt? [1]

(b) How did the distance between the torch and the object affect the length of the shadow formed on the screen? [1]

(c) Using the same set-up and without moving the screen and the torch, describe how Sally could decrease the length of the shadow formed on the screen. [1]

| | |
|-------|---|
| Score | 3 |
|-------|---|

34. Samy tied a balloon over one end of a straw as shown in the diagram below.

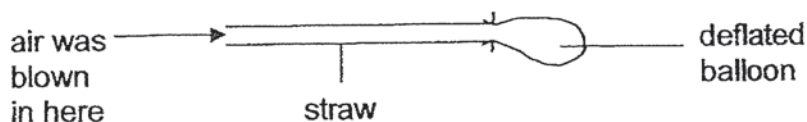

He conducted two experiments and recorded his observations in the table below.

| Experiment | Procedure | Observation |
|------------|--|------------------------------------|
| 1 | He blew air through the straw. | The balloon became bigger. |
| 2 | He inserted the deflated balloon into a tank filled with water as shown in the diagram below and blew air through the straw. | The balloon did not become bigger. |

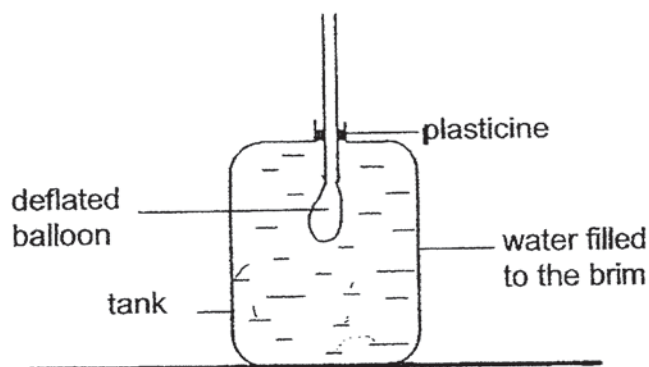

(a) Explain why the balloon in experiment 1 became bigger when Samy blew air through the straw. [1]

(b) Explain why the balloon in experiment 2 did not become bigger when Samy blew air through the straw. [2]

(c) What should Samy do if he wants to inflate the balloon in experiment 2? [1]

| | |
|-------|---|
| Score | 4 |
|-------|---|

35. Cracks appeared on the pavement when the air becomes cold as shown in the diagram below.

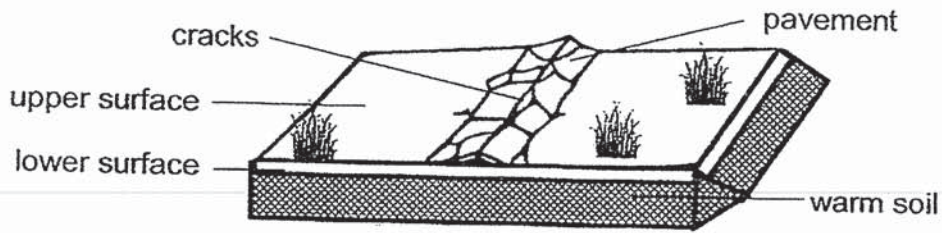

- (a) Explain how the cold air and warm soil caused the pavement to crack. [2]

Concrete slabs are laid on pavements with gaps in between as shown in the diagram below.

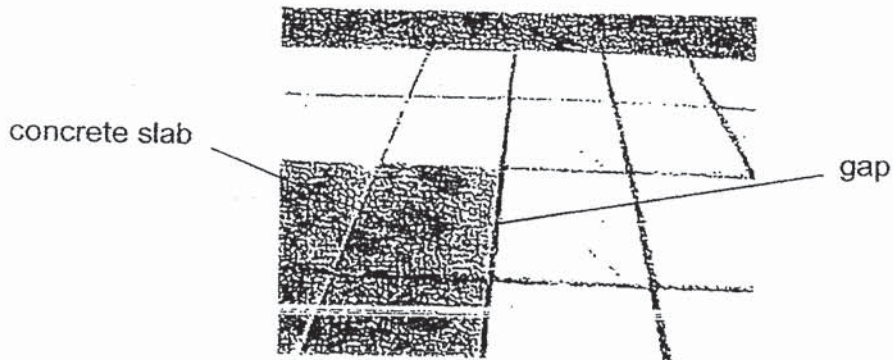

- (b) How do the gaps in between the concrete slabs prevent the pavement from cracking on a hot sunny day? [2]

| | |
|-------|---|
| Score | 4 |
|-------|---|

36. Celine wanted to find out if the type of material affects the time taken for the water to boil. She heated three saucepans, X, Y and Z, made of different materials with different amounts of tap water as shown below.

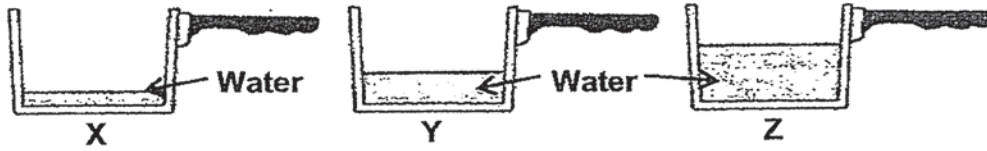

- (a) Celine's teacher said that her experiment was not a fair test. Which two variables must Celine keep the same to ensure a fair test? [2]

(i) _____

(ii) _____

After making the changes to her experiment to ensure a fair test and using the same amount of heat, Celine plotted a graph as shown below to show the results of her experiment.

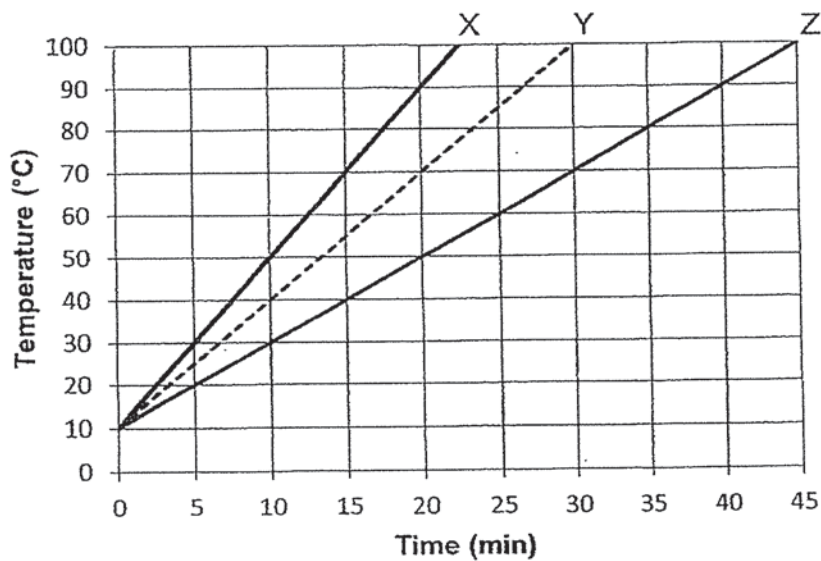

- (b) If Celine wants to cook a bowl of noodles over a flame in the shortest time, which saucepan, X, Y or Z, should she use? Explain your answer with reference to the graph above. [2]

| | |
|-------|---|
| Score | 4 |
|-------|---|

37. Lisa wants to make a bag for her younger sister to put her water bottle and umbrella. She has four materials, A, B, C and D. The table below shows some properties of the materials.

| Properties | Materials | | | |
|------------|-----------|-----|-----|-----|
| | A | B | C | D |
| Flexible | No | Yes | Yes | No |
| Strong | Yes | Yes | No | Yes |
| Waterproof | Yes | Yes | Yes | No |

- (a) Based on the table above, describe Material A. [1]

- (b) Which material, A, B, C or D, is the best for making the bag for her sister? [1]

Lisa's sister put her water bottle filled with water into a bag. The bag broke when she lifted it up.

- (c) Using the information given in the table above, which material, A, B, C or D, is the bag most likely be made of? [1]

| | |
|-------|---|
| Score | 3 |
|-------|---|

38. Addy used the electrical method to turn a steel rod into an electromagnet. He used the same number of batteries and recorded his observations in the table below.

| | | | | |
|---|----|----|----|----|
| Number of coils of wire around the steel rod | 10 | 20 | 30 | 40 |
| Number of paper clips attracted to the electromagnet | 2 | 5 | | 11 |

- (a) Complete the table above by predicting the number of paper clips which will be attracted to the electromagnet when there were 30 coils of wire around the steel rod. [1]

- (b) Identify the independent variable (changed variable) in this experiment. [1]

- (c) What is the relationship between the number of coils of wire around the steel rod and strength of the electromagnet? [1]

- (d) Besides the electrical method, name another method to make a temporary magnet. [1]

| | |
|-------|---|
| Score | 4 |
|-------|---|

39. Study the table below. A tick (✓) represents the presence of the characteristic.

| | Breathe through gills | Can swim | Has legs | Has scales | Lay eggs |
|-----------------|-----------------------|----------|----------|------------|----------|
| Animal D | ✓ | ✓ | | ✓ | ✓ |
| Animal E | | ✓ | ✓ | | ✓ |

(a) Based on the table above, state all the similarities between animals D and E. [1]

(b) Based on the table above, state how are animals D and E different in their outer coverings. [1]

(c) Match animals D and E to the animal below by writing the letters 'D' or 'E' in each box. [1]

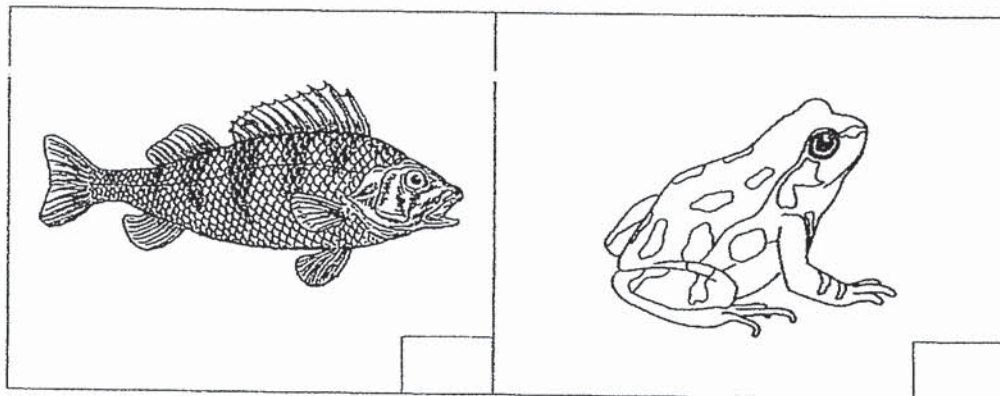

| | |
|-------|---|
| Score | 3 |
|-------|---|

40. Study the diagram below.

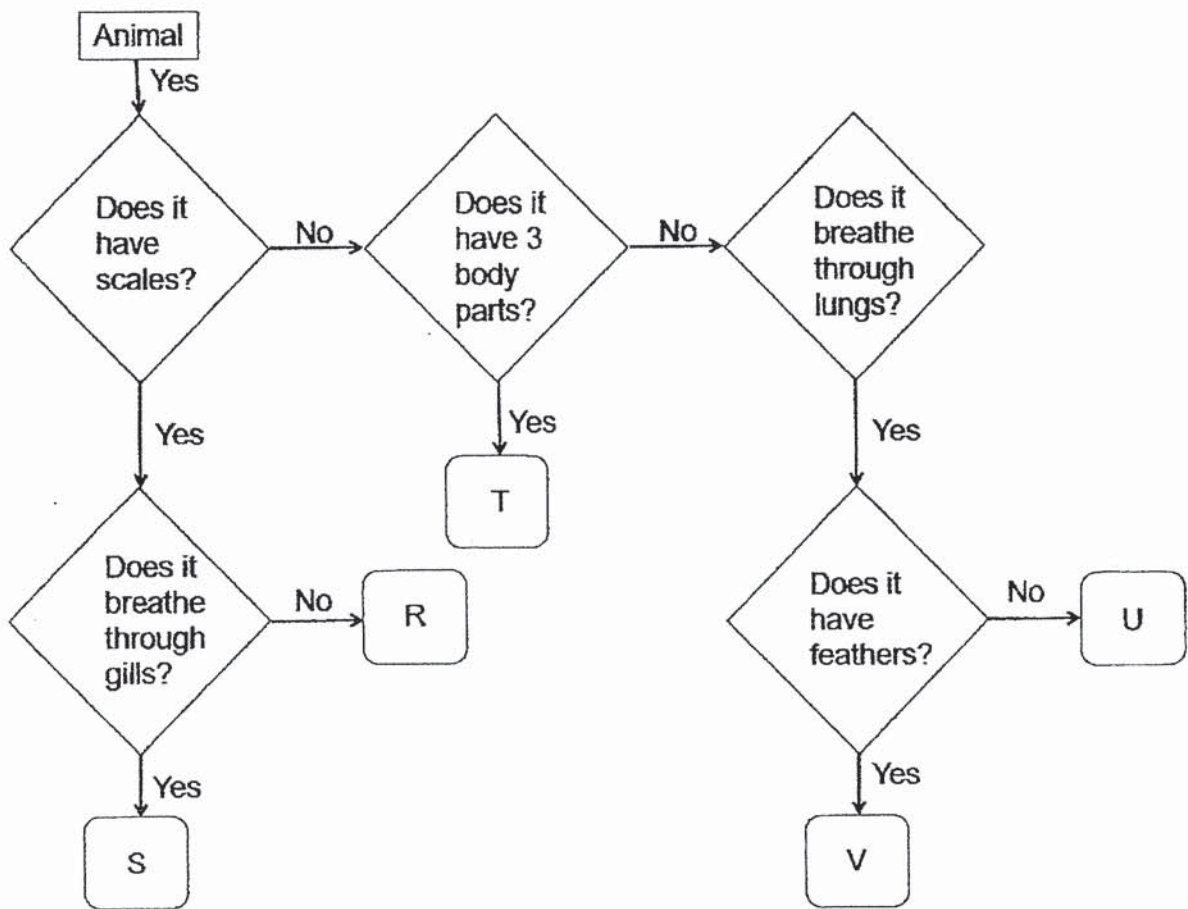

(a) Based on the diagram above, state two similarities between U and V. [2]

(b) Based on the diagram above, state one difference between R and S. [1]

(c) Based on the diagram above, which letter, R, S, T, U or V, would best represent a cat? [1]

End of Booklet B

| | |
|-------|---|
| Score | 4 |
|-------|---|

ANSWER KEY

YEAR : 2019
LEVEL : PRIMARY 4
SCHOOL : NAN HUA PRIMARY
SUBJECT : SCIENCE
TERM : SA 1

BOOKLET A

| | | | | | | | | | |
|-----|---|-----|---|-----|---|-----|---|-----|---|
| Q1 | 4 | Q2 | 2 | Q3 | 2 | Q4 | 4 | Q5 | 3 |
| Q6 | 3 | Q7 | 1 | Q8 | 1 | Q9 | 3 | Q10 | 1 |
| Q11 | 3 | Q12 | 3 | Q13 | 4 | Q14 | 2 | Q15 | 3 |
| Q16 | 2 | Q17 | 3 | Q18 | 2 | Q19 | 1 | Q20 | 1 |
| Q21 | 2 | Q22 | 2 | Q23 | 3 | Q24 | 1 | Q25 | 4 |
| Q26 | 2 | Q27 | 1 | Q28 | 4 | | | | |

BOOKLET B

Q29a) i: Light travels in straight lines.

ii: Light can be reflected.

Q29b) We can see the moon as the moon reflects light from the sun into our eyes.

Q29c) The sun

Q30a) (Draw at 50)

Q30b) Water has no definite shape and water has a definite volume.

Q31a) The temperature of water

Q31b) The temperature of hot water decreased as the water lost heat to the surrounding air.

Q31c) Both the air and water have the same temperature so the water will not lose anymore heat to the air.

Q32a) i: Incorrect ii: Not possible to tell iii: Correct

Q32b) The North-south direction

Q33a) The torch was moved closer to the object.

Q33b) When the distance between the torch and the object decreases, the length of the shadow increases.

Q33c) Move the object closer to the screen.

Q34a) Air occupied space in the balloon.

Q34b) Water occupied space in the tank and could not be compressed so air could not enter the balloon to occupy space in it.

Q34c) He should remove some water.

Q35a) The upper surface of the pavement lost heat to the cold air and contracted but the lower surface of the pavement gained heat from the warm soil and expanded. That causes a crack.

Q35b) The gaps provide space for the concrete slabs to expand when they gain heat from the sun.

Q36a) i: The amount of tap water

ii: The size of the saucepans

Q36b) Saucepan X. It is the best conductor of heat as the temperature of water increased the fastest so the noodles will gain heat from the flame and cook the fastest.

Q37a) Material A is strong, waterproof and not flexible.

Q37b) Material B

Q37c) Material C

Q38a) 8

Q38b) The number of coils of wire around the steel rod.

Q38c) As the number of coils of wire around the steel rod increases, the strength of the electromagnet also increases.

Q38d) The stroking method

Q39a) They lay eggs and can swim.

Q39b) Animal D has scales but animal E does not.

Q39c) D, E

Q40a) U and V breathe through lungs and does not have 3 body parts.

Q40b) S breathe through gills but R does not.

Q40c) U

3
END