

**SINGAPORE CHINESE GIRLS' SCHOOL
SECOND SEMESTRAL ASSESSMENT 2014
PRIMARY 5 SCIENCE**

Name: _____ () Date: _____

Class: Primary 5

**SCIENCE
BOOKLET A**

30 questions

60 marks

Total Time For Booklets A & B: 1 h 45 min

DO NOT OPEN THIS BOOKLET UNTIL YOU ARE TOLD TO DO SO.

FOLLOW ALL INSTRUCTIONS CAREFULLY.

Part I (60 marks)

For each question from 1 to 30, four options are given. One of them is the correct answer. Make your choice (1, 2, 3 or 4). **Shade the correct oval (1, 2, 3 or 4) on the Optical Answer Sheet.**

1. Andy placed a plant in an opaque box that has 2 openings, A and B, in a dark room. Next, he placed a light source just outside Opening B as shown in the diagram below. He watered it regularly:

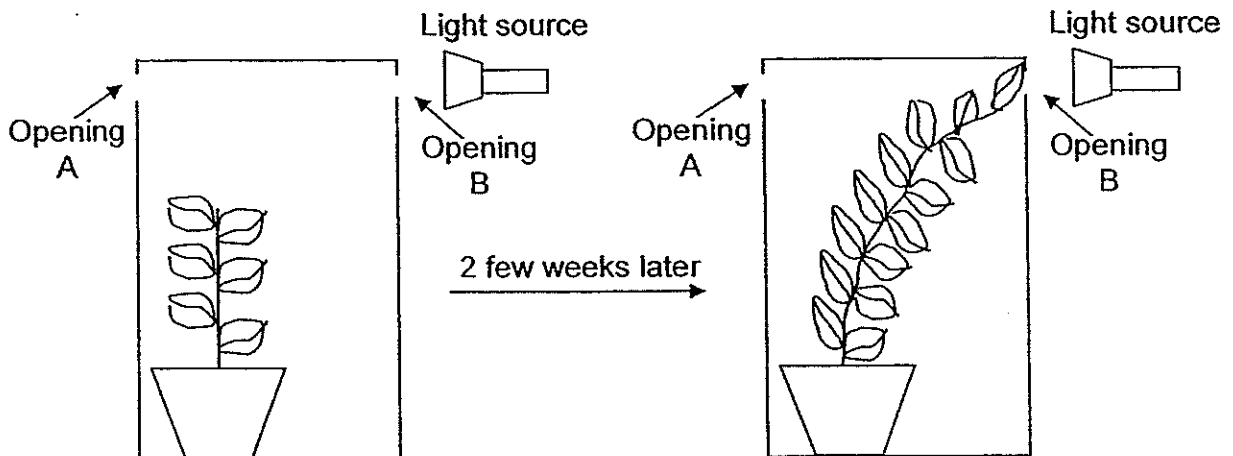

2 weeks later, he noticed that the plant grew towards Opening B. Which one of the following best explains why the plant grew towards Opening B?

- 1) Plants respond to light. 3) Plants need water to grow.
2) Plants need air to grow. 4) Plants make their own food.
2. Bernice placed Object X on a table. She observed that Object X moved when she touched it and immediately concluded that it is a living thing. However, Candy insisted that she should observe other characteristics of Object X before making such a conclusion.

Which other characteristics of living things should Bernice observe about Object X to be definitely sure that it is a living thing?

- A: Observe if Object X can reproduce.
B: Observe if Object X can move in water.
C: Observe if Object X can become bigger.
D: Observe if Object X needs air, food and water to survive.

- 1) A and C only 3) B and C only
2) A and D only 4) B, C and D only

3. Study the classification chart below.

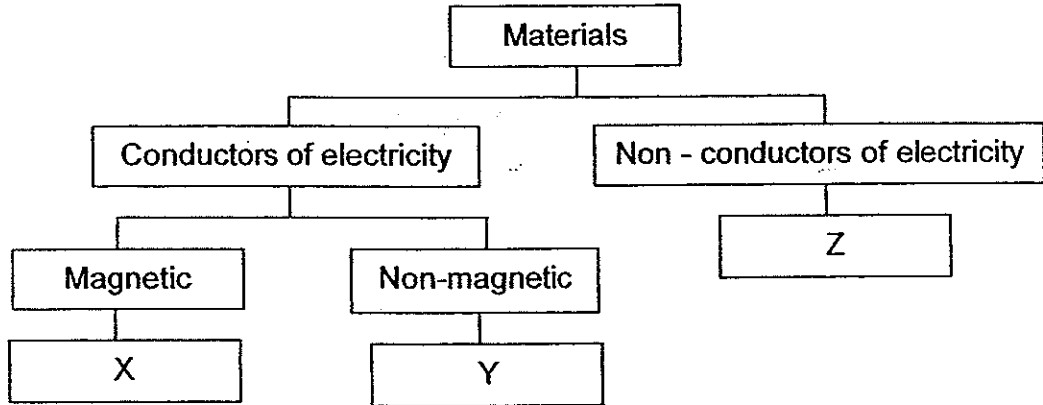

Which of the following can be placed in X, Y and Z respectively?

	X	Y	Z
1)	Iron	Steel	Glass
2)	Aluminium	Iron	Steel
3)	Steel	Aluminium	Glass
4)	Glass	Steel	Iron

4. The diagram below shows a system found in the human body.

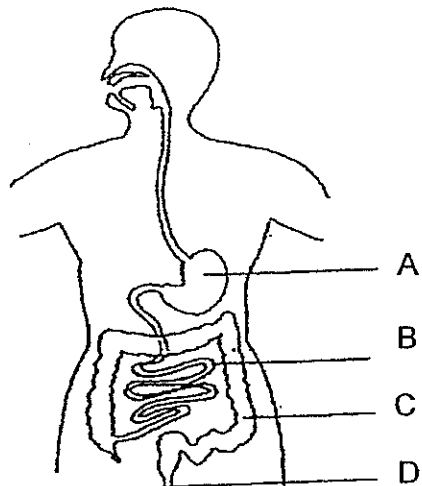

Which one of the following parts absorbs digested food?

- 1) A
- 2) B
- 3) C
- 4) D

7. The graph below shows the composition of air in our surroundings.

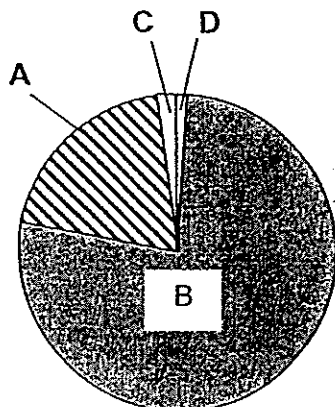

Which of the following is used by the human body during respiration?

- 1) A
- 2) B
- 3) C
- 4) D

8. Cynthia carried out activities A, B, C and D. After each activity, she immediately breathed out through a straw into a beaker of limewater. She then recorded the time taken for the limewater to turn chalky in the table below. She rested for 30 minutes before carrying out the next activity.

Activity	Time taken to turn limewater chalky
A	83 seconds
B	45 seconds
C	58 seconds
D	30 seconds

Based on the table above, which activity required the most amount of oxygen and energy?

- 1) A
- 2) B
- 3) C
- 4) D

9. The diagram below shows how the different human systems work together.

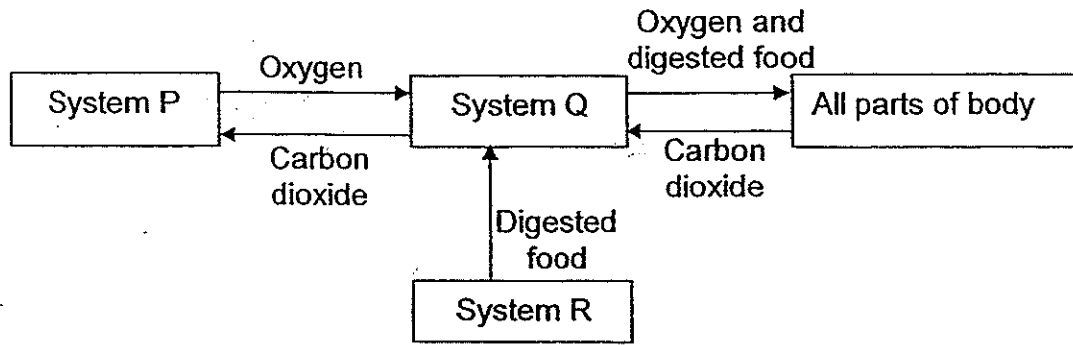

Which of the following correctly represents Systems P, Q and R?

	System P	System Q	System R
1)	Respiratory	Circulatory	Digestive
2)	Circulatory	Respiratory	Digestive
3)	Digestive	Circulatory	Respiratory
4)	Respiratory	Digestive	Circulatory

10. Denise cut 2 rings of different thickness, Part X and Part Y, from a stem and removed them from the plant as shown below.

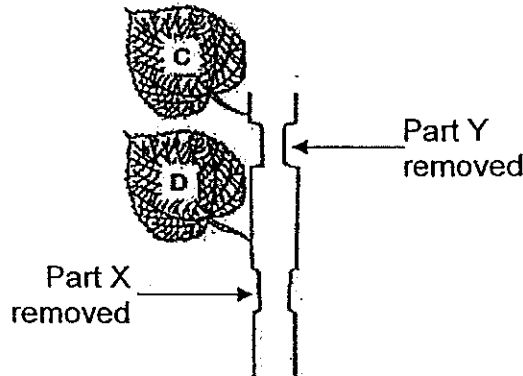

She recorded her observation of Leaves C and D after 1 week in the table below.

Leaf	Observations
C	Brown and wilt
D	Remains green and healthy

Which one of the following correctly shows the correct parts removed?

	Part X	Part Y
1)	Food-carrying tubes only	Food-carrying tubes only
2)	Food-carrying tubes only	Food-carrying tubes and water carrying tubes
3)	Food-carrying tubes and water carrying tubes	Food-carrying tubes only
4)	Food-carrying tubes and water carrying tubes	Food-carrying tubes and water carrying tubes

11. Study the 4 electrical set-ups shown below.

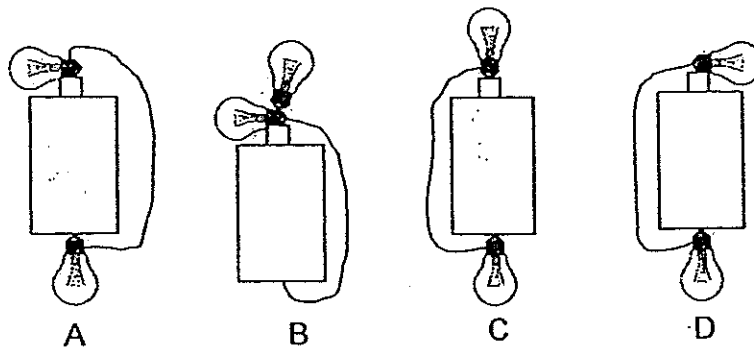

Which of the following set-ups will enable both bulbs to light up?

- 1) A and B only
- 2) C and D only
- 3) A, B and C only
- 4) B, C and D only

12. Helen constructed a circuit as shown below with materials W, X, Y and Z. All bulbs and batteries are in working condition.

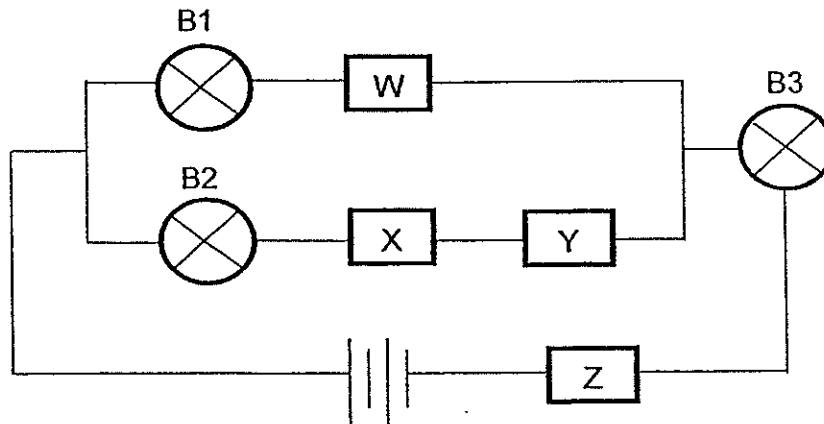

Bulb	Lights up
B1	✓
B2	x
B3	✓

Which of the following materials are definitely conductors of electricity?

- 1) W and X only
- 2) X and Y only
- 3) W and Z only
- 4) Y and Z only

13. Study the circuit below carefully.

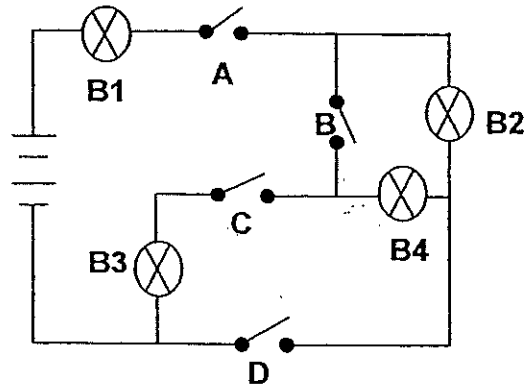

What is the least number of switches that need to be closed so that all the bulbs will light up?

- 1) 1
- 2) 2
- 3) 3
- 4) 4

14. Study the 4 circuits below. The batteries and bulbs used are identical and in working condition.

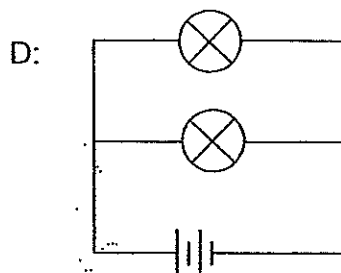
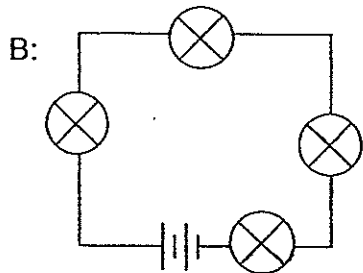
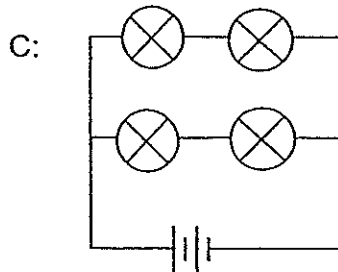
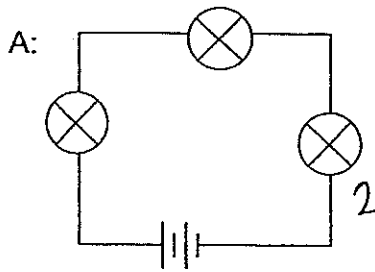

Which of the following correctly shows the arrangement of the circuits in order, starting from the one with the dimmest bulbs to the one with the brightest bulbs.

- 1) D, A, B, C
- 2) C, B, D, A
- 3) B, A, C, D
- 4) A, B, D, C

15. Genie placed Magnets W and P at 10cm apart on a table as shown below. Both magnets did not interact with each other. A ping pong ball was placed just beside Magnet P.

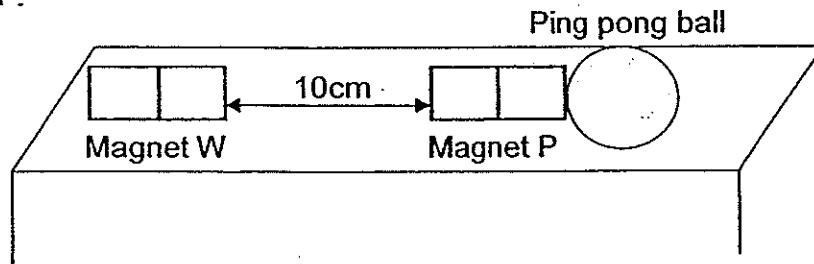

She then pushed Magnet W slowly towards Magnet P and observed the distance between the 2 magnets when the ping pong ball moved.

She repeated the above steps for Magnets X, Y and Z and recorded the results in the table below.

Magnet	Distance between the magnets when the ping pong ball moved
W	2.7 cm
X	2.2 cm
Y	3.8 cm
Z	1.7cm

Which of the following conclusions are correct about the above experiment?

- A; Magnet Y has the weakest magnetic force.
- B; The ping pong ball rolled due to the force of repulsion.
- C: Magnet X has a stronger magnetic force than Magnet Z.
- D: Magnet W has a stronger magnetic force than Magnet P.

- 1) A and B only
- 2) B and C only
- 3) C and D only
- 4) A, C and D only

16. Olivia placed a seed in wet soil and the diagram below shows the growth of the seed into a seedling over a period of time.

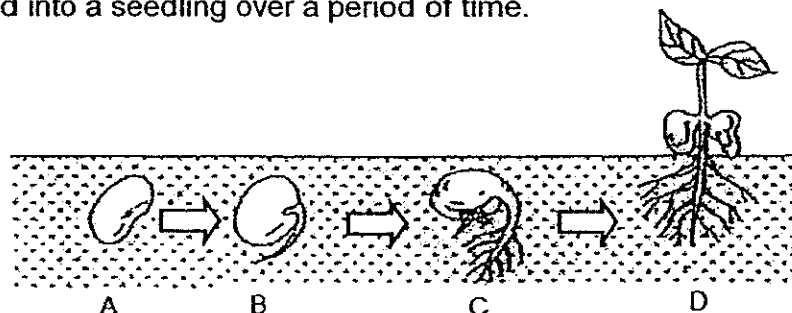

At which of the stages do the seed/seedling require oxygen?

- 1) A and B only
- 2) C and D only
- 3) A, B and C only
- 4) A, B, C and D

17. Study Paul's family tree below.

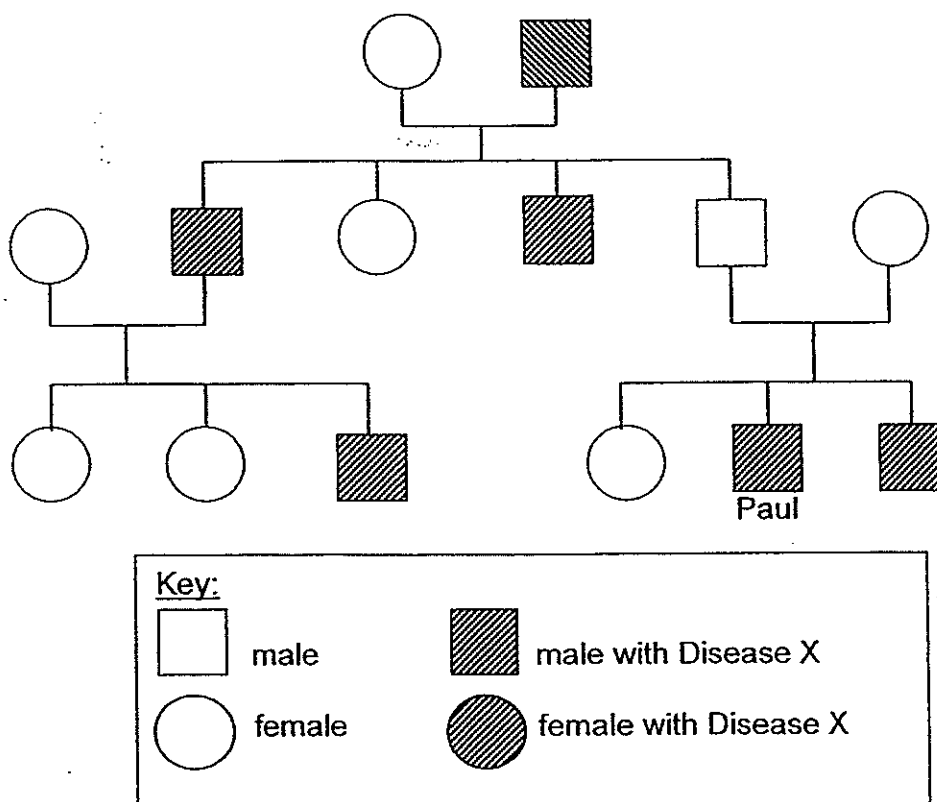

Based on the family tree above, which of the following conclusion/s is/are correct?

- A: Paul has a brother with Disease X.
- B: Paul has inherited Disease X from his uncle.
- C: All the males in Paul's family has Disease X.
- D: None of the females in Paul's family has disease X.

- 1) A and D only
- 2) B and C only
- 3) B, C and D only
- 4) A, B and D only

18. The diagram below shows a cross-section of a flower with parts labelled A, B, C and D.

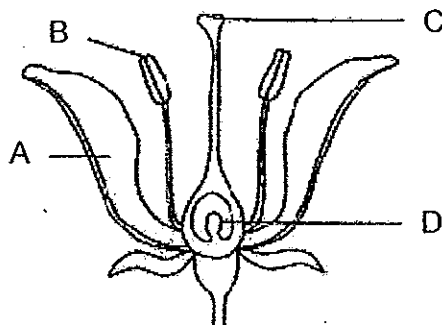

Which parts must the above flower at least have in order to produce a fruit?

- 1) A and B
- 2) B and C
- 3) B and D
- 4) C and D

19. The diagram below shows the life cycle of a plant.

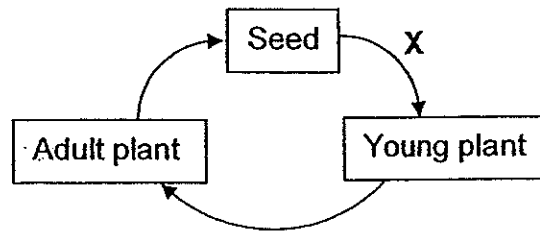

Which of the following process/es will take place at X?

- | | |
|----------------|------------------|
| A: Dispersal | C: Germination |
| B: Pollination | D: Fertilisation |
- 1) A only
2) A and C only
3) B and D only
4) B, C and D only

20. Study the diagram below.

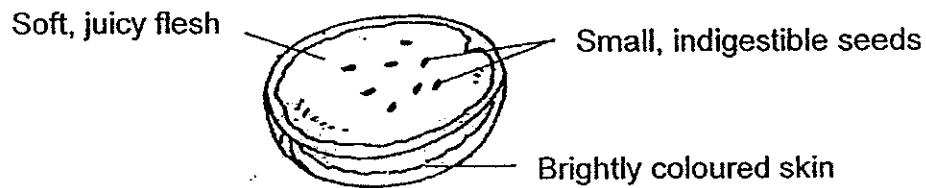

Based on the information from the diagram above, which of the following statements about the fruit are correct?

- A: The seeds are dispersed by wind.
B: The flower of the plant is pollinated by animals.
C: The flower of the plant has many ovules in the ovary.
D: Pollination and fertilisation processes must have taken place.
- 1) A and B only
2) C and D only
3) A, B and C only
4) A, C and D only

21. The diagram below shows a process that takes place in a human body.

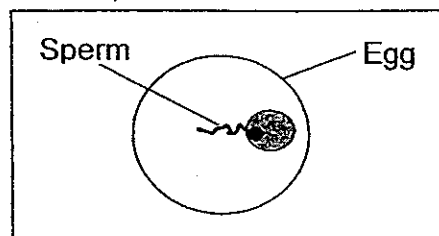

Which of the following shows the same process in a plant?

- | | |
|------------------|-------------------|
| 1) Pollination | 3) Germination |
| 2) Fertilisation | 4) Seed dispersal |

22. Study the flow chart below.

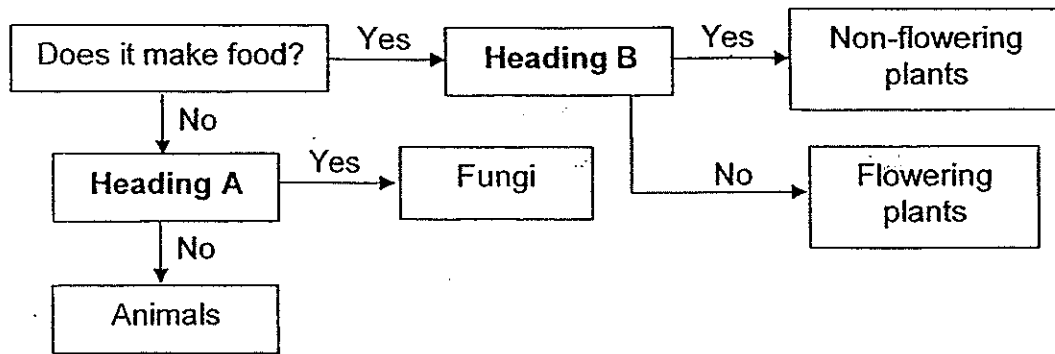

Which one of the following correctly represents Headings A and B respectively?

	Heading A	Heading B
1)	Does it lay eggs?	Does it live on trees?
2)	Does it reproduce by spores?	Does it reproduce by seeds?
3)	Does it lay eggs?	Does it have flowers?
4)	Does it reproduce by spores?	Does it reproduce by spores?

23. The diagram below shows how the processes X, Y and Z are involved in the water cycle.

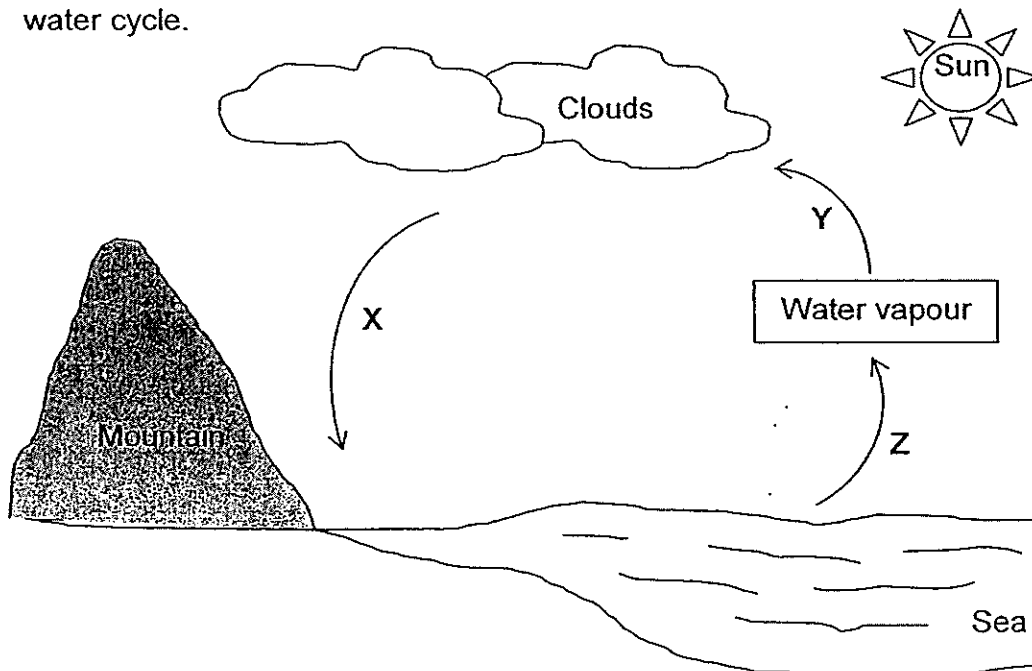

Which of the following statement/s is/are correct?

- A: Water loses heat in Process Y.
- B: Water loses heat in Process Z.
- C: Water changes from a liquid to a gas in Process X.

- 1) A only
- 2) B only
- 3) B and C only
- 4) A, B and C

24. A, B and C represent the 3 states of water.

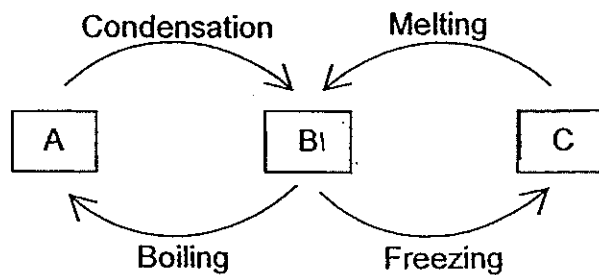

Which of the following correctly shows the states of water at A, B and C?

	A	B	C
1)	Solid	Liquid	Gas
2)	Liquid	Solid	Gas
3)	Gas	Liquid	Solid
4)	Solid	Gas	Liquid

25. The graph below shows substances K and V. Substance K becomes a gas at 100°C while Substance V becomes a gas at 120°C.

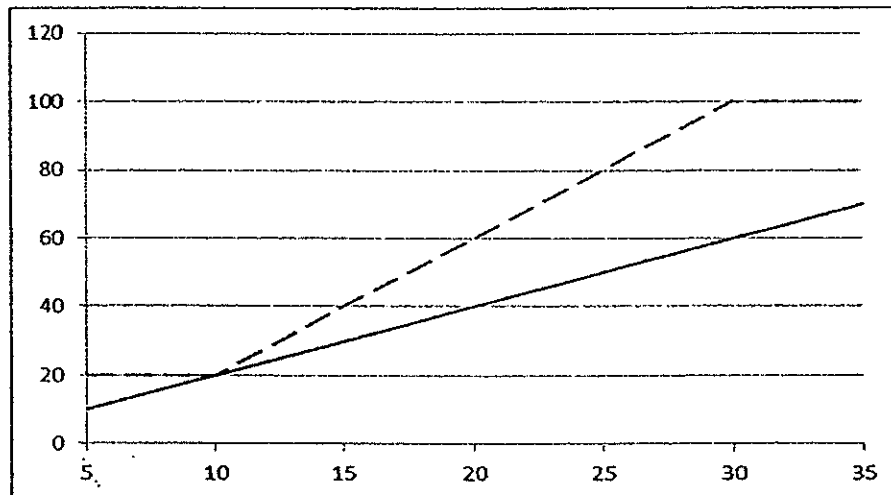

<u>Key:</u>	
---	Substance K
—	Substance V

Based on the graph above, which one of the following statements below is correct?

- 1) The boiling point of Substance K is 80°C.
- 2) The melting point of Substance V is 20°C.
- 3) Both Substance K and Substance V are at liquid state at the beginning.
- 4) Substance V takes a longer time to reach boiling point than Substance K.

26. Which of the following is/are produced by plants during photosynthesis?

A: sugar

B: starch

C: carbon dioxide

- 1) A only
- 2) C only

- 3) A and B only
- 4) A, B and C

27. The diagram below shows 3 containers with some water.

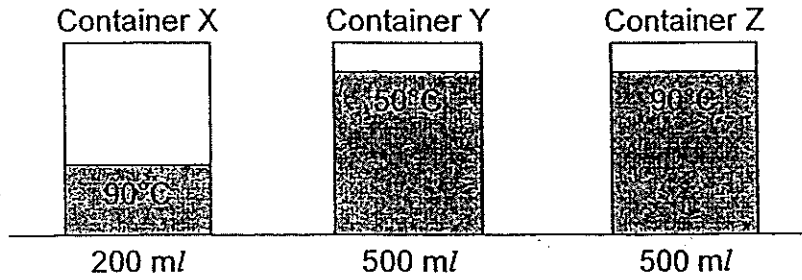

Based on the diagrams above, which of the following statement/s is/are correct?

- 1) X has less heat than Z.
- 2) Z has less heat than Y.
- 3) Y and Z have the same amount of heat.
- 4) X and Z have the same amount of heat.

28. Winnie placed a packet of milk in a basin of water as shown below for 30 minutes. She recorded their temperatures in the graph below.

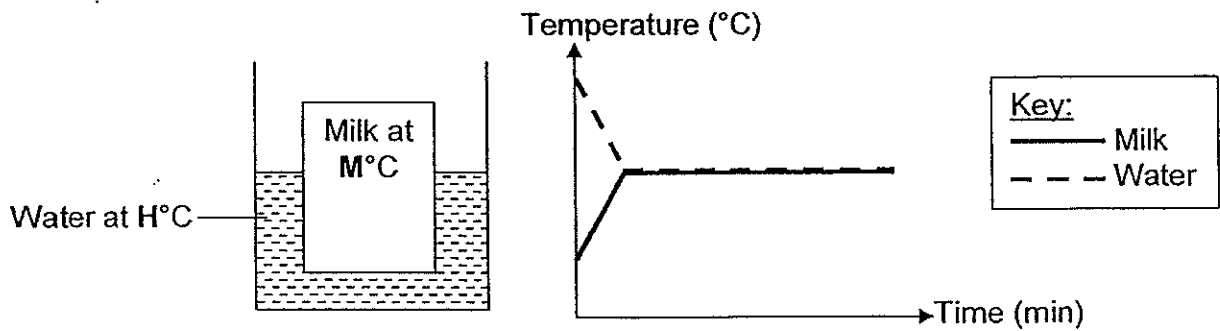

Which one of the following is most likely to be $M^{\circ}\text{C}$ and $H^{\circ}\text{C}$?

	Temperature of milk at the start ($M^{\circ}\text{C}$)	Temperature of water at the start ($H^{\circ}\text{C}$)
1)	30	30
2)	90	10
3)	90	90
4)	10	90

29. Which one of the following best explains why the girl is able to see the bee?

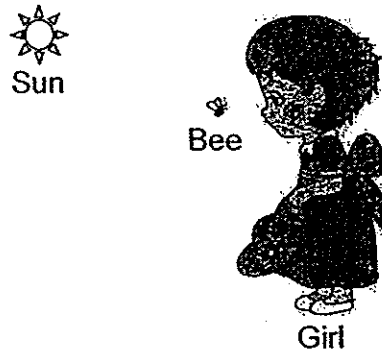

- 1) The sun reflects light to the bee.
- 2) The girl's eyes reflect light onto the bee.
- 3) The bee reflects light into the girl's eyes.
- 4) The light reflects from the girl's eyes to the bee.

30. Ali conducted an experiment as shown below. He shone a torch at different materials and used a light sensor with a datalogger to measure the amount of light that passed through each material. He recorded the results in the table below.

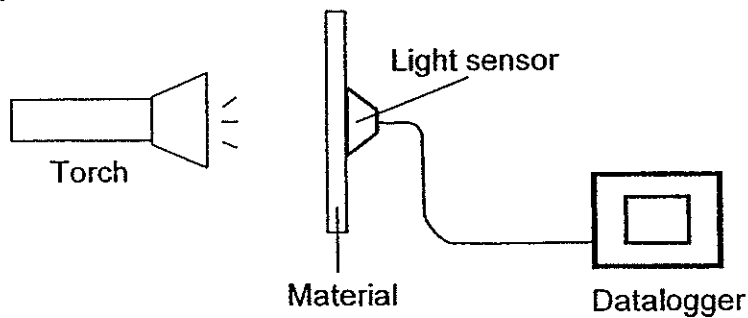

Material	Amount of light detected (Lux)
A	87
B	1050
C	0
D	205

Based on the table above, which is the best material to make the door of a public toilet?

- 1) A
- 2) B
- 3) C
- 4) D

**SINGAPORE CHINESE GIRLS' SCHOOL
SECOND SEMESTRAL ASSESSMENT 2014
PRIMARY 5 SCIENCE**

Name: _____ () Date: _____

Class: Primary 5

Components	Marks Obtained	Total Marks
Booklet A		60
Booklet B		40
Total		100

_____ Parent's Signature

SCIENCE

BOOKLET B

14 questions

40 marks

Total Time For Booklets A & B: 1 h 45 min

DO NOT OPEN THIS BOOKLET UNTIL YOU ARE TOLD TO DO SO.

FOLLOW ALL INSTRUCTIONS CAREFULLY

Name: _____ ()

Date: _____

Class: Primary⁵

Part II (40 marks)

Answer all the following questions.

31. Daniel used materials A, B, C and D to conduct an experiment. He fixed each material on a retort stand and pushed one end of each material till it cannot be bent any further.

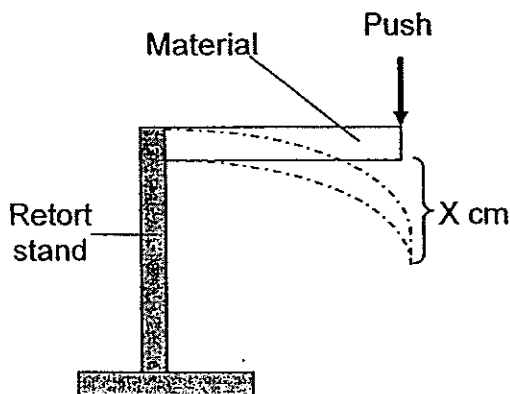

He recorded the distance, X cm, that each material had to be pushed downwards till it cannot be bent any further.

Material	X (cm)
A	10
B	15
C	8
D	6

- a) Based on the above experiment, which property of material was Daniel trying to find out? (1m)

- b) Daniel had carried out a fair test. Put a tick (✓) in the appropriate box/es to indicate the variables that Daniel must have definitely kept the same for his experiment. (1m)

Variables		
i)	Type of material	<input type="checkbox"/>
ii)	Colour of the material	<input type="checkbox"/>
iii)	Thickness of the material	<input type="checkbox"/>
iv)	Distance each material has been pushed down	<input type="checkbox"/>

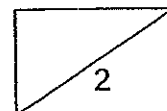

32. Elaine observed Cells A and Cells B through a microscope and drew the outline of the cells as shown below.

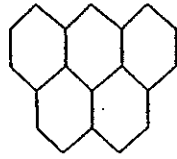

Cells A

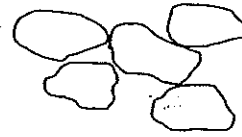

Cells B

- a) Elaine concluded that Cells A are plant cells while Cells B are not. Do you agree with her? Explain your answer. (1m)

- b) Elaine placed one of Cells B into a container and added a red solution into the container. Her observations are shown below.

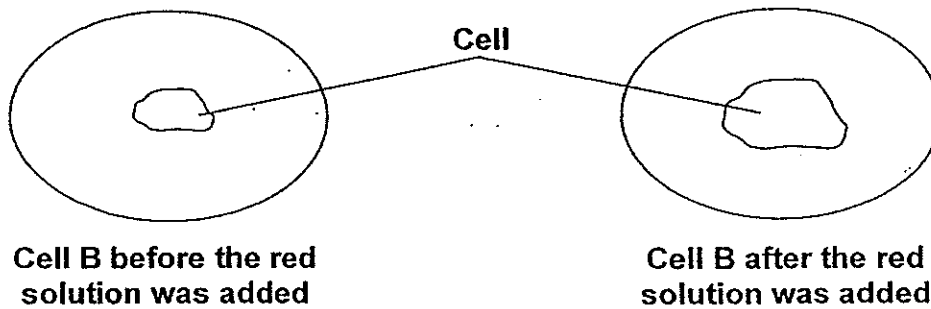

- i) Based on her observations, Elaine concluded that the red solution went into Cell B. Which cell part allowed ~~Solution X~~ the red solution to enter? (1m)

- ii) What should Elaine observe in Cell B under a microscope to prove that the red solution had entered Cell B? (1m)

33. Siti placed a pot of plant as shown below in an open garden. She watered the plant regularly. The upper side and underside of all leaves on Part A were coated with black paint while only the upper side of all the leaves on Part B were coated with black paint.

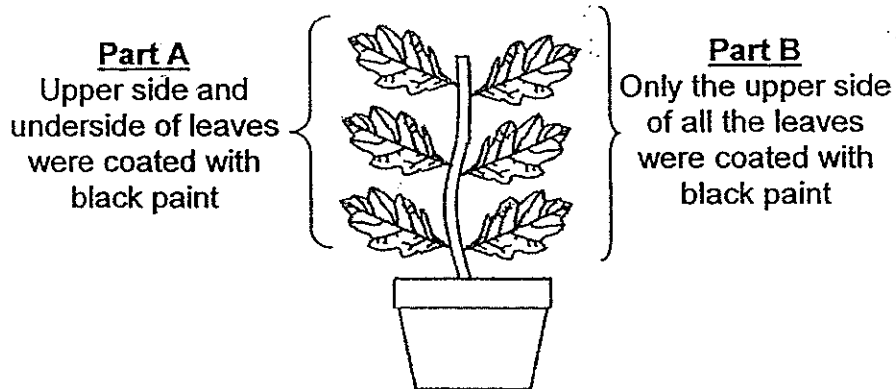

- a) After a week, all the leaves on Part A died but all the leaves on Part B survived. Explain why this happened. (2m)

Siti conducted another experiment using a similar plant. She coated only the upper side of all the leaves with black paint.

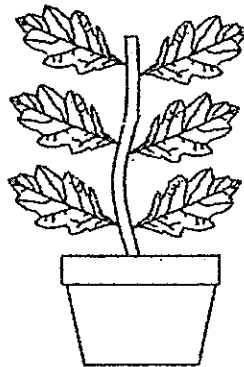

- b) After 2 weeks, the plant died. Explain why this happened. (1m)

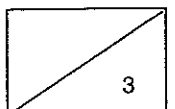

34. Jenny made a circuit tester and a circuit board as shown below.

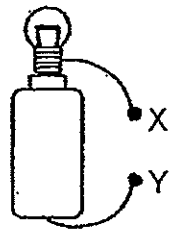

Circuit Tester

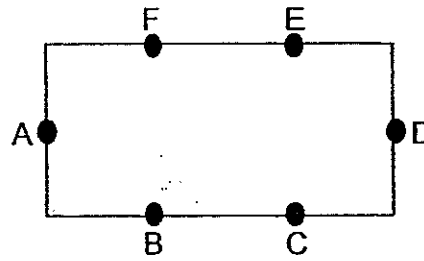

Circuit board

She connected the circuit tester to different points of the circuit board and recorded her observations in the table below.

Connection points	Does the bulb light up?
AB	No
AC	No
AD	Yes
BC	No
BE	No
BF	No
CD	No
CE	No
DE	No
DF	Yes
EF	No

Based on the above observation, draw 3 possible connections of the circuit board using only 2 straight lines in each diagram. (3m)

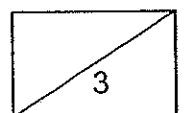
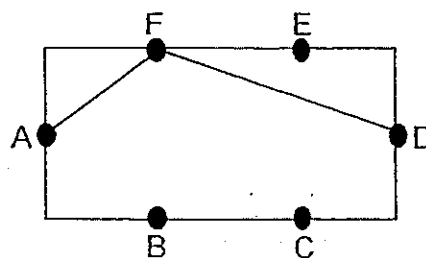
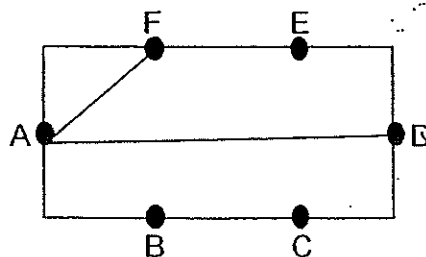
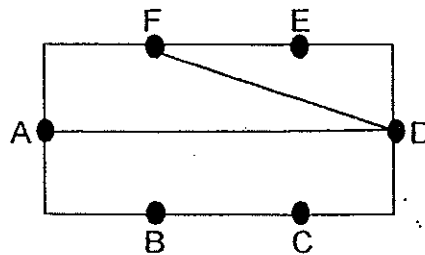

35. Felicia used the “stroke” method on Rod X and Rod Y as shown below. She used the same number of strokes on both rods using 2 magnets of equal magnetic strength.

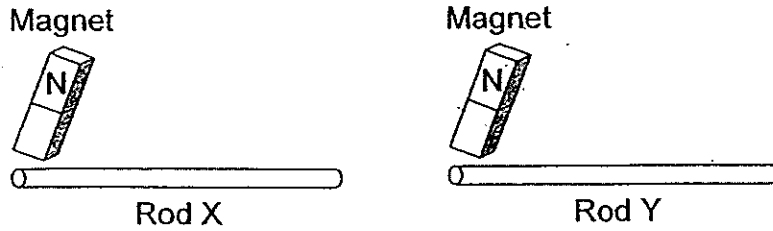

She then took turns to place the rods into a bowl of paper clips and recorded the number of paper clips each rod could attract in the table below.

Rod	Paper clips attracted
X	0
Y	5

- a) Explain why Rod Y was able to attract the paper clips while Rod X was unable to. (2m)

- b) List 2 things that Felicia could do to Rod Y to make it attract more paper clips using the “stroke” method. (1m)

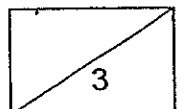

36. The graph below shows the different stages of life cycles of Animals A, B and C.

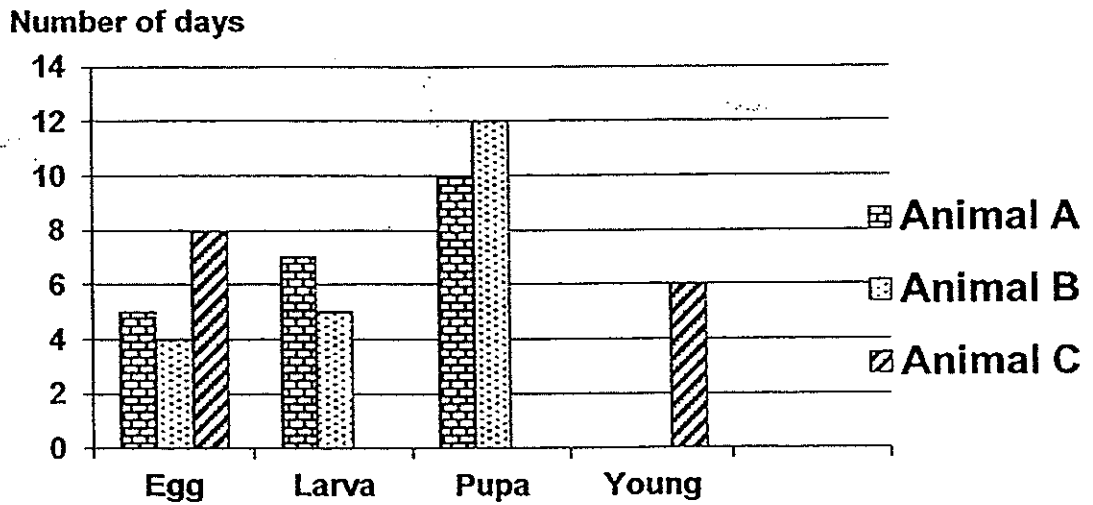

a) How many stages are there in the life cycle of Animal B? (1m)

b) From the graph, Mary said that Animal A is definitely a frog. Do you agree with her? Explain your answer. (1m)

c) How many days would Animal B take to become an adult after the egg is laid? (1m)

d) Based on the graph, Mary concluded that Animal C has the shortest life. Do you agree with her? Explain your answer. (1m)

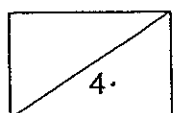

37. The diagram below shows 4 types of plant P, Q, R and S in year 2010 and 2011.

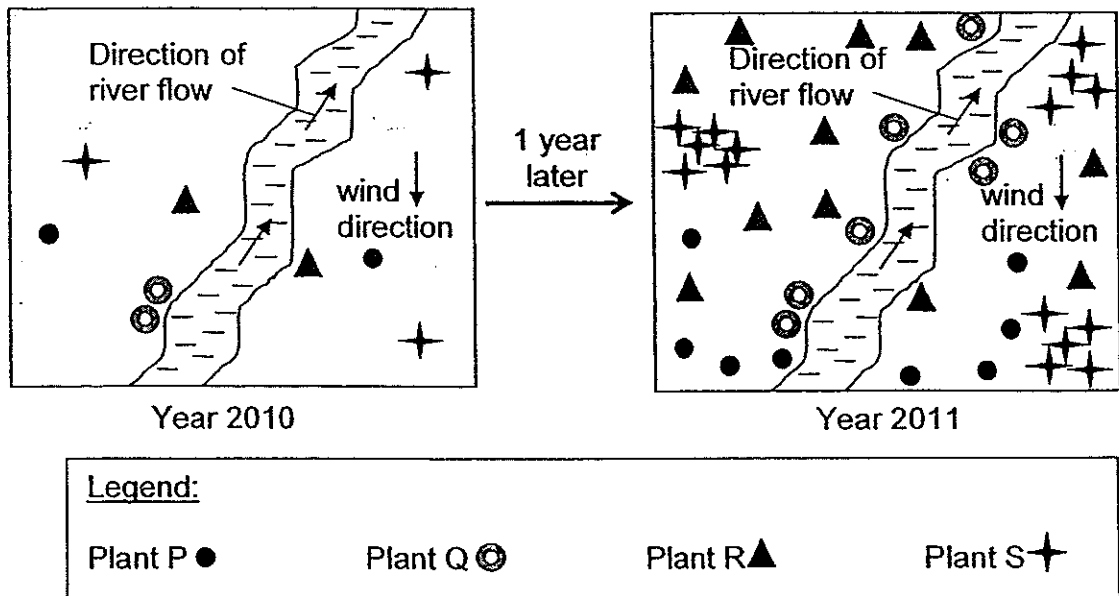

a) Based on the diagrams above, identify the method of dispersal for Plants P, Q, R and S. Fill in the table below. (2m)

	Method of seed dispersal	Plant
i)	By water	
ii)	By splitting	
iii)	By animals	
iv)	By wind	

b) Explain why there is less overcrowding for the young of Plant R as compared to the young of Plant S. (1m)

38. Susie filled 3 containers completely with substances A, B and C respectively. Next, she used a plunger and tried to add an additional 250 cm^3 of the same substance into each container as shown in the diagram below.

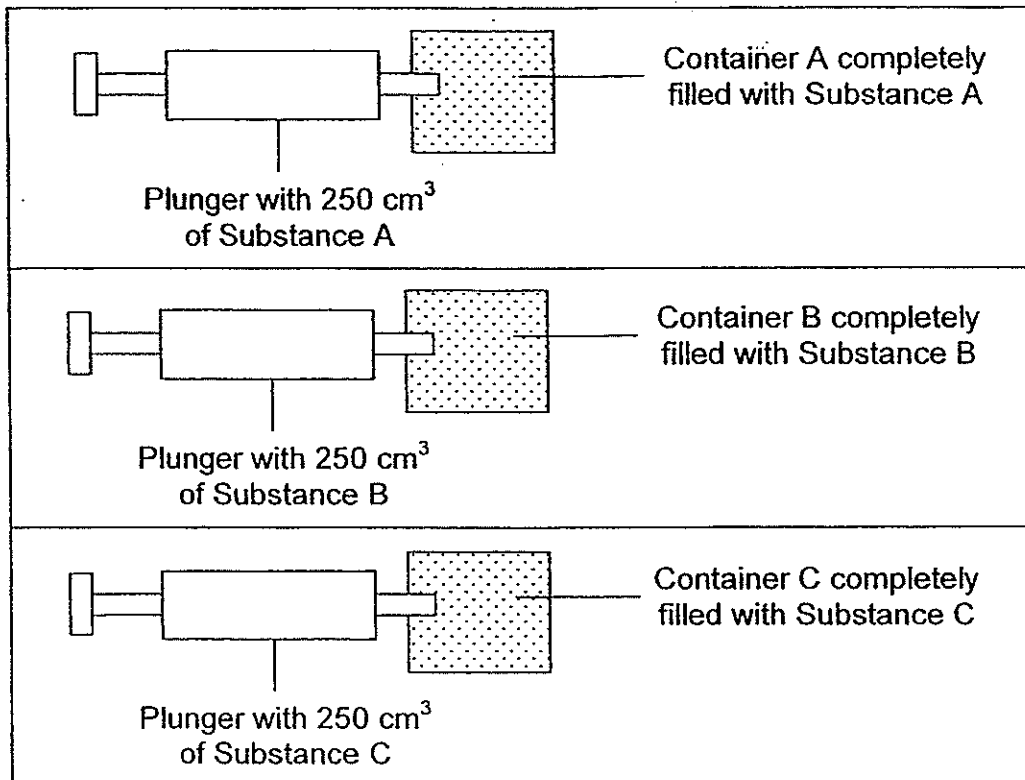

Susie recorded her observation as she pushed the plunger into each container below.

Containers	Observations
A	The additional 250 cm^3 of Substance A was able to enter into Container A.
B	The additional 250 cm^3 of Substance B was unable to enter Container B.
C	The additional 250 cm^3 of Substance C was unable to enter Container C.

Put a tick (\checkmark) in the appropriate column to indicate the conclusions that can be made from Susie's observations. (3m)

	Conclusion	True	False	Not possible to tell
a)	Substance A is a solid.			
b)	Substance B is a liquid.			
c)	Substance C can be compressed.			

39. In the setup below, Kelly heated some red solution till it boiled and produced Substance X. Substance X then entered Point P of a glass tube. A cool gel at 2°C was wrapped around the glass tube. This caused pure water to drip out from the glass tube through Point Q which was collected in Container B.

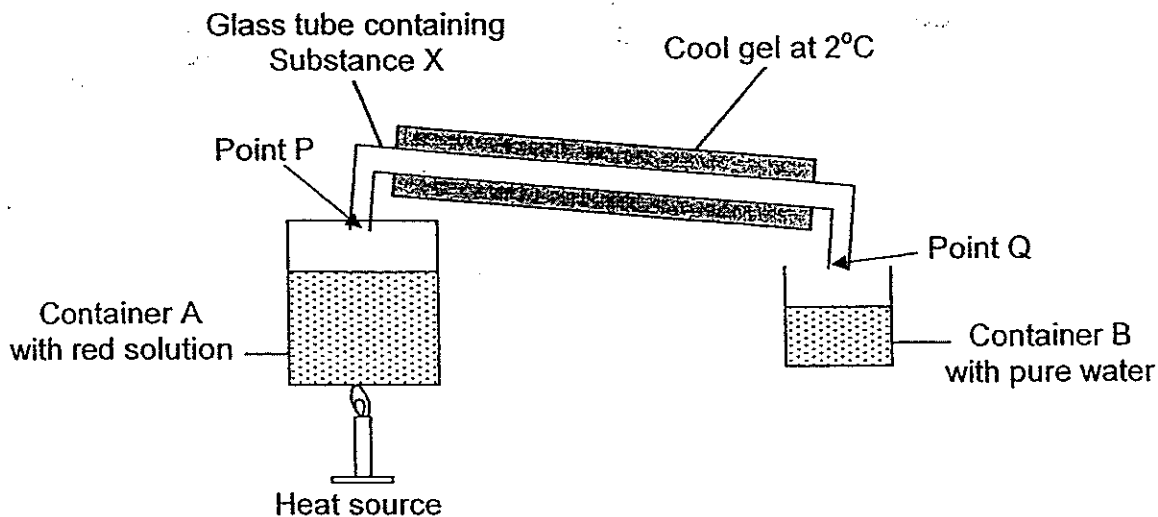

- a) What was Substance X? (1m)

- b) Kelly conducted another experiment. This time, the cool gel that was wrapped around the glass tube was at 25°C.

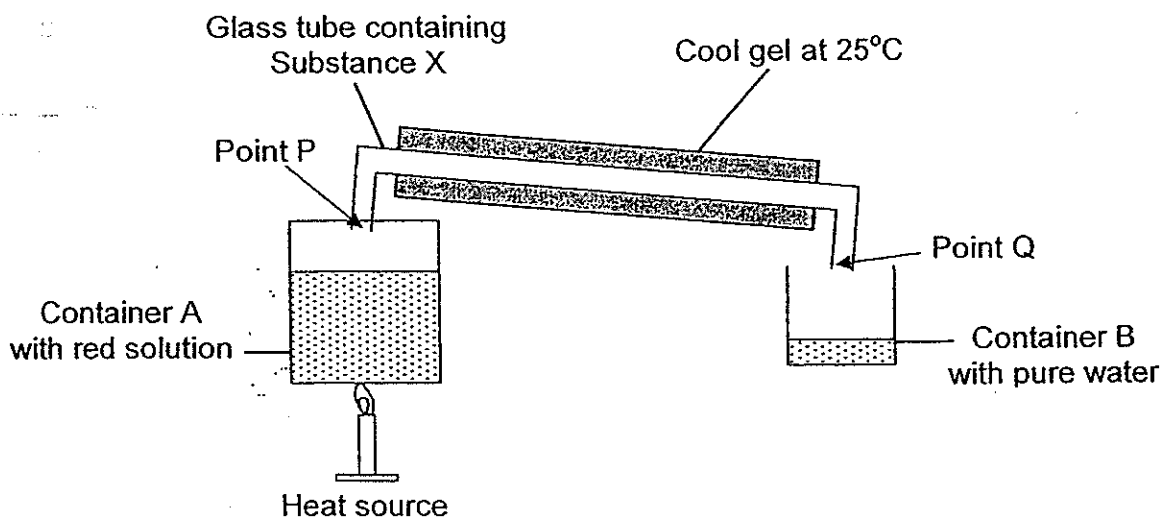

Explain why the amount of water collected in Container B was lesser as compared to the first experiment. (2m)

40. Xiang Wen was given 4 different types of containers with the same capacity as shown below to investigate how the rate of evaporation is affected by the exposed surface area of water.

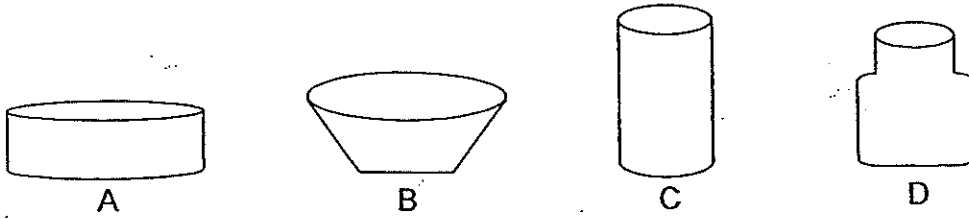

- a) Xiang Wen's teacher told her that she should not use Containers B and D in her experiment. Explain why her teacher said so. (1m)

- b) An equal amount of water was poured into Containers A and C, then Containers A and C were placed in an open field for 5 hours.

Complete the bar graph to show the amount of water left in Container C at the end of the experiment. (1m)

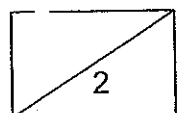
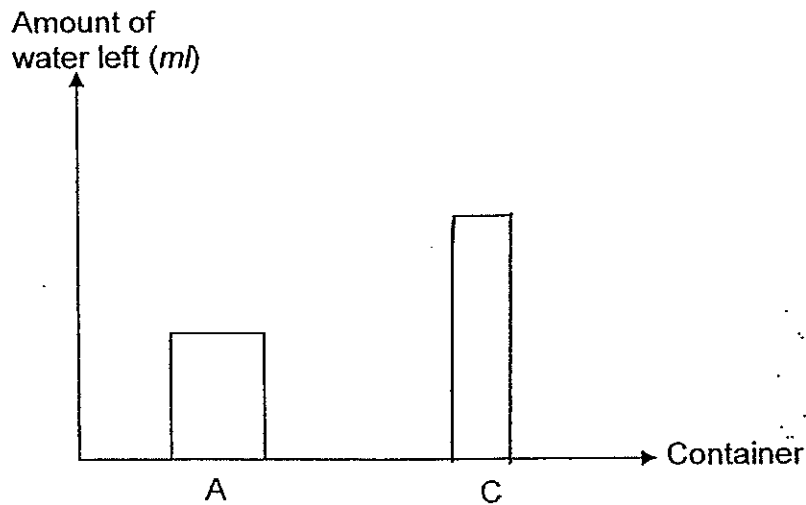

41. Sam conducted an experiment to find out if the distance of the light source will affect the rate of photosynthesis. He set up 4 set-ups, A, B, C and D with similar plants. Each set-up is placed at a different distance from the lamp. A test tube was used to collect the gas as shown in the set-up below.

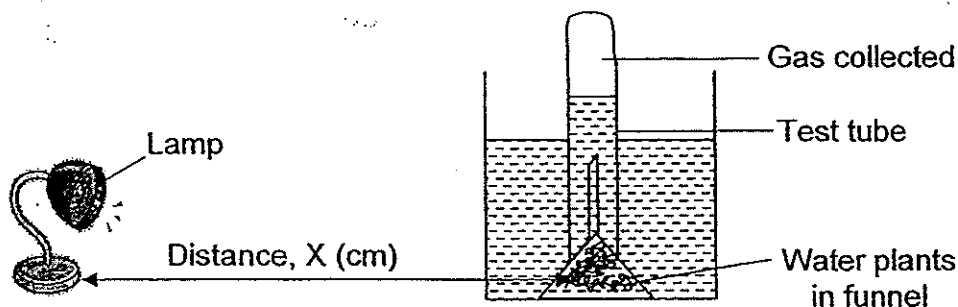

He carried out the experiment for one hour and measured the volume of gas collected at the end of the experiment.

Set-up	Distance between light source and water plants, X (cm)	Volume of gas collected in the test tube (cm ³)
A	40	1
B	30	2
C	20	3
D	10	4

- a) Name the gas collected in the test tube. (1m)
- _____
- b) Based on Sam's results in the table above, how does the distance between the light source and the plant affect the volume of gas collected? (1m)
- _____
- _____
- c) Sam continued his experiment using only Set-up D for another hour. However, he noticed that the volume of gas collected did not increase. Explain why this happened. (1m)
- _____
- _____

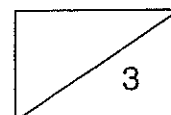

42. James conducted an experiment using different types of solids and liquids. He heated each of them with the same amount of heat and recorded the results of the experiment in the tables below.

Solid	Volume before heating	Volume after heating
A	100 cm ³	106 cm ³
B	100 cm ³	118 cm ³
C	100 cm ³	113 cm ³

Liquid	Volume before heating	Volume after heating
P	100 cm ³	125 cm ³
Q	100 cm ³	122 cm ³
R	100 cm ³	131 cm ³

- a) Based on the results in the tables above, what can James conclude about the similarities between solids and liquids when they are heated? (1m)

- b) Based on the results in the tables above, what can James conclude about the differences between solids and liquids when they are heated? (1m)

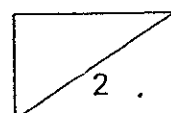

43. Jaime heated 300 ml of water in each of the 2 containers which were of the same size but made of different materials as shown below.

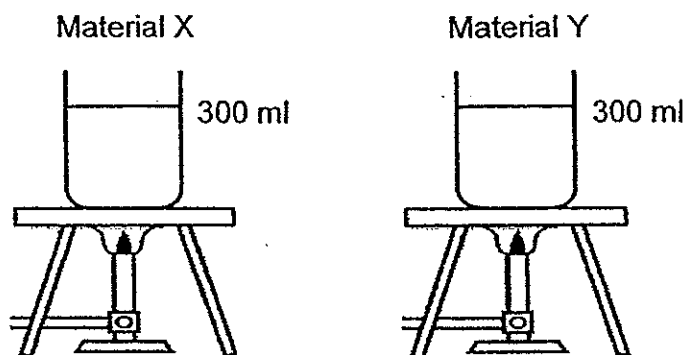

- a) The water in the container made of Material X took 20 mins to reach boiling point while the water in the container made of Material Y took 30 mins to reach boiling point. Explain why the water in the container made of Material X reached boiling point first. (2m)

Jaime conducted another experiment using a container made of Material P and a container made of Material Q. She poured 300 ml of water at 90°C into each container and left them on a table in a room.

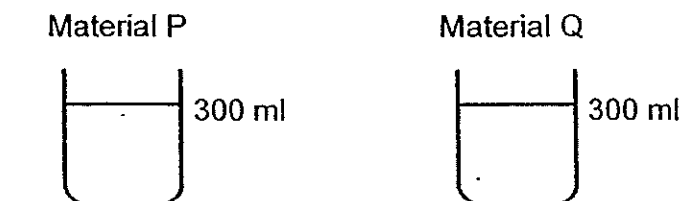

- b) The water in the container made of Material P cooled down to room temperature first. Which material, P or Q, is a poorer conductor of heat? (1m)

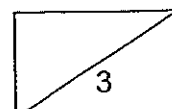

44. Alice placed 4 different objects between a torch and a screen as shown below.

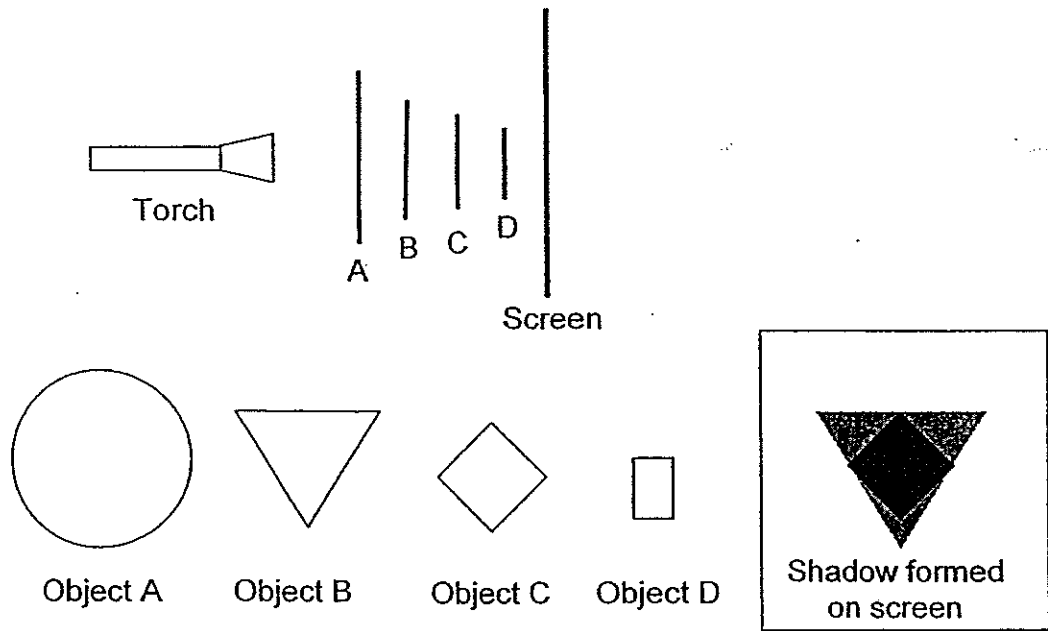

a) Which of the object/s is/are definitely transparent? (1m)

Alice switched the positions of Objects B and C as shown below.

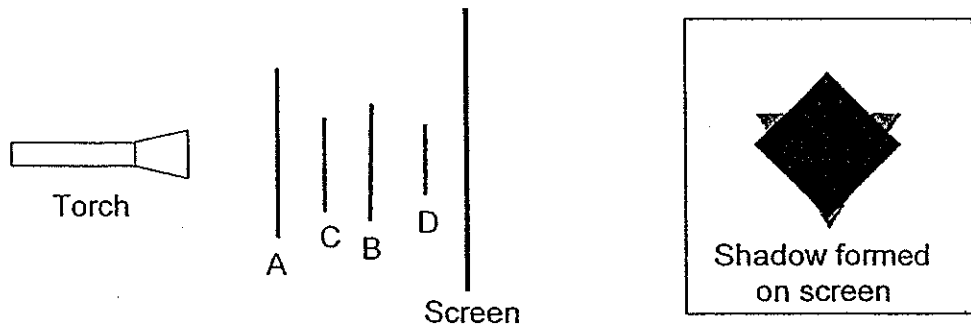

b) Explain why there was a change in the shadow formed on the screen when the positions of Objects B and C were changed. (2m)

PRIMARY 5 SCIENCE SA2 2014

1) 1	6) 3	11) 2	16) 4	21) 2	26) 1
2) 2	7) 1	12) 3	17) 1	22) 4	27) 1
3) 3	8) 4	13) 2	18) 4	23) 1	28) 4
4) 2	9) 1	14) 3	19) 2	24) 3	29) 3
5) 4	10) 2	15) 2	20) 2	25) 4	30) 3
Qn	Suggested Answer				
31a	Flexibility				
31b	Variables				
	i)	Type of material			
	ii)	Colour of the material			
	iii)	Thickness of the material		✓	
iv)	Distance each material has been pushed down				
32a	Yes. Cells A have regular shape as they have cell wall but Cells B do not have regular shape as they do not have cell walls.				
32bi	Cell membrane				
32bii	Observe if red solution is inside Cell B.				
33a	The leaves on Side A died because the stomata were blocked so the leaves could not carry out respiration but (most of) the stomata on the leaves on Side B were not blocked so it could carry out respiration.				
33b	The leaves could not receive light to carry out photosynthesis / to make food.				
34					
35a	Rod Y is made of magnetic material so it can be made into a magnet but Rod X is not made of magnetic material so it cannot be made into a magnet .				
35b	Stroke Rod Y with the magnet more times. Use a stronger magnet to stroke Rod Y.				
36a	4				
36b	No. Animal A has the larva / pupa stage. / Animal A has 4 stages in its life cycle.				
36c	21				
36d	No. The number of days / duration each animal stays as an adult is not shown on the graph.				

37a	i)	Method of seed dispersal	Plant			
		By water	Q			
	ii)	By splitting	S			
	iii)	By animals	R			
	iv)	By wind	P			
37b	The young of Plant R is further away from its parent plant as compared to Plant S.					
38		Conclusion	True	False	Not possible to tell	
	a)	Substance A is a solid.		✓		
	b)	Substance B is a liquid.			✓	
	c)	Substance C can be compressed.		✓		
39a	Water vapour / Steam					
39b	The temperature difference between the Substance X and the glass tube / cool gel was smaller so condensation took place at a slower rate.					
	OR: The 25°C cool gel was not as cold as before, thus steam/ water vapour took a longer time to lose heat and condense into water droplets.					
40a	The exposed surface area in Containers B and D is not the same throughout the experiment.					
40b	<p>Amount of water left (ml)</p> <p style="text-align: center;">A C → Container</p>					
41a	Oxygen					
41b	The longer the distance between the light source and the plant, the less the amount of gas collected.					
41c	There was not enough carbon dioxide left for the plant to carry out photosynthesis.					
42a	Solids and liquids expand when heated.					
42b	Solids expands less than liquids when heated.					
43a	Material X is made of a better conductor of heat than Material Y so it can conduct heat to the water faster than Container Y.					
43b	Material Q					
44a	Object A					
44b	Object B was moved nearer the screen so its shadow becomes smaller while Object C was moved further from the screen so its shadow becomes bigger.					
	OR: Object B was moved further from the light source so its shadow becomes smaller while Object C was moved nearer to the light source so its shadow becomes bigger.					