



NAN HUA PRIMARY SCHOOL
SEMESTRAL ASSESSMENT 2 – 2017
PRIMARY 5

SCIENCE

BOOKLET A

28 Multiple Choice Questions (56 marks)

Total Time for Booklets A and B : 1 hour 45 minutes

INSTRUCTIONS TO CANDIDATES

1. Write your name and index number in the space provided.
2. Do not turn over the page until you are told to do so.
3. Follow all instructions carefully.
4. Answer all questions.
5. Shade your answers in the Optical Answer Sheet (OAS) provided.

Marks Obtained

Booklet A		/ 56
Booklet B		/ 44
Total		/ 100

Name: _____ () Class: P 5 _____

Date : 31 October 2017

Parent's Signature: _____

Section A: (28 x 2 marks = 56 marks)

For each question from 1 to 28, four options are given. One of them is the correct answer. Make your choice (1, 2, 3 or 4). Shade the correct oval (1, 2, 3 or 4) on the Optical Answer Sheet.

1. Which of the following traits can a child inherit from his/her parents?

- A Fingerprints
- B Colour of skin
- C Length of hair
- D Colour of eyes

- | | |
|---------------------|---------------------|
| (1) A and C only | (2) B and D only |
| (3) A, B and D only | (4) B, C and D only |

2. The picture below shows the female reproductive system.

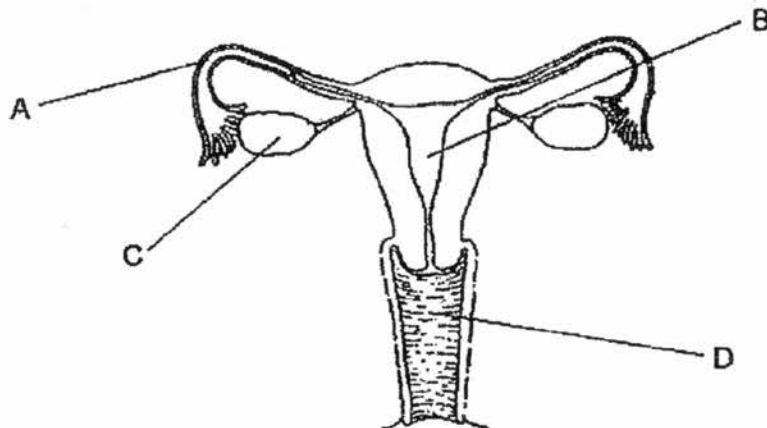

At which location will the fertilised egg grow into a foetus?

- (1) A
- (2) B
- (3) C
- (4) D

3. The diagram below represents the transport system of a plant.

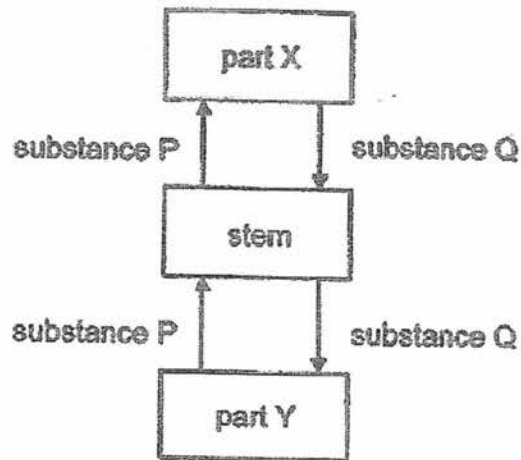

Which of the following correctly identifies parts X and Y, and substances P and Q?

	part X	part Y	substance P	substance Q
(1)	leaf	root	sugar	mineral salts
(2)	root	leaf	water	sugar
(3)	root	leaf	mineral salts	water
(4)	leaf	root	water	sugar

4. Four blood samples, R, S, T and U, were taken from different blood vessels in different parts of the human body. The graph below shows the amount of carbon dioxide found in each of the blood samples.

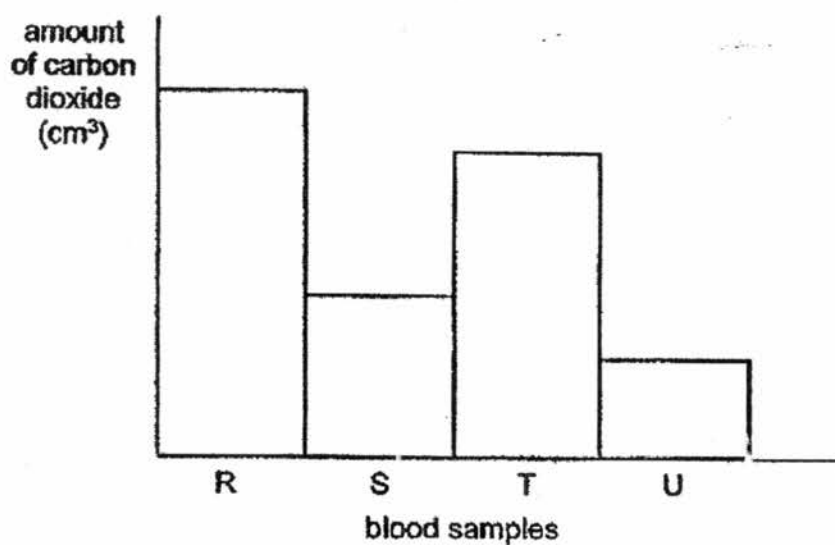

Which blood sample was most likely taken from the blood vessel carrying blood from the heart back to the lungs?

- (1) R
- (2) S
- (3) T
- (4) U

5. Mary wrote down some statements about the cell as shown below.

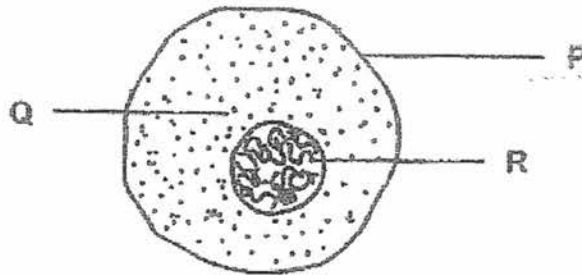

- A Q is a jelly-like substance.
B P gives the cell a regular shape.
C R controls the activities within the cell.

Which of the statements written by Mary are true?

- (1) A and B only
(2) A and C only
(3) B and C only
(4) A, B and C

6. Sue conducted an experiment on two different organisms, X and Y. She left the organisms in the set-ups shown below for 1 week.

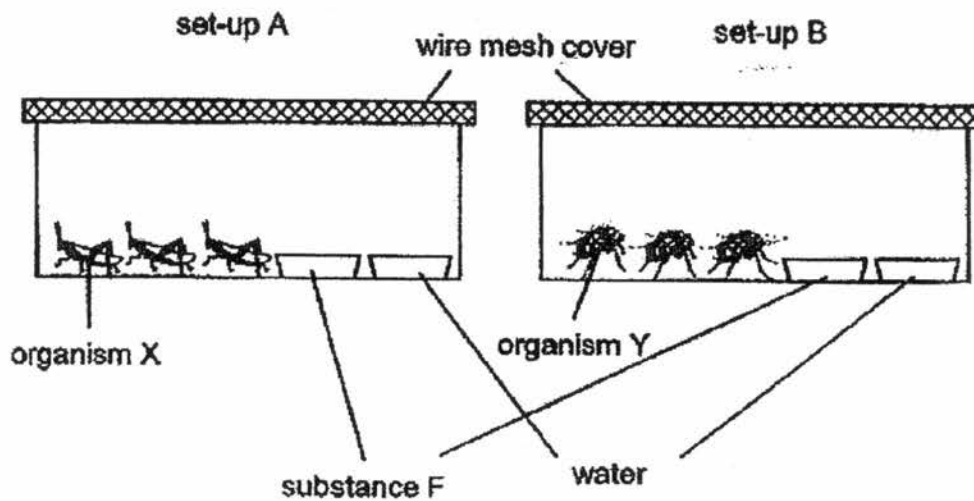

She observed how well the organisms survived and recorded the number of organisms left after 1 week in the table below.

Set-up	Number of organisms	
	At the start of the experiment	At the end of the experiment
A	3	3
B	3	0

Based on the results above, which of the following statement(s) is/are true?

- A Substance F is a source of food for X.
- B Y does not have enough air for survival.
- C Y does not have food and water to survive.
- D X can carry out its life processes as it is able to obtain energy from the water.

- (1) A only
- (2) A and D only
- (3) B and C only
- (4) B, C and D only

7. Study the diagram below.

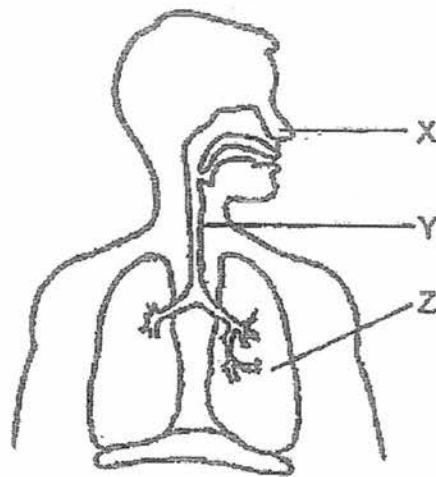

Which one of the following correctly matches the labelled parts.

	Part X	Part Y	Part Z
(1)	Filters dust and harmful gases entering the body	Transports oxygen from Part X to Part Z	Takes In oxygen needed by the body
(2)	Traps dust particles in the air that we breathe in	Transports air from Part X to Part Z	Enables exchange of gases to take place
(3)	Traps dust particles in the air we breathe out	Transports oxygen from Part X to Part Z	Gives out carbon dioxide released from the body
(4)	Filters germs and harmful gases entering the body	Transports carbon dioxide from Part X to Part Z	Enables exchange of gases to take place

8. Annie carried out an investigation on the growth of seedlings. She set up the experiment in the diagram shown below.



seedling A
(seed leaves present)



seedling B
(seed leaves removed)

Both containers are left in a dark room and the same amount of water is given daily. She observed the growth of both seedlings for 5 days.

Graph A shows how the mass of seedling A and the seed leaves changes over 10 days whereas graph B shows how the mass of the seedling B changes over the same period of time.

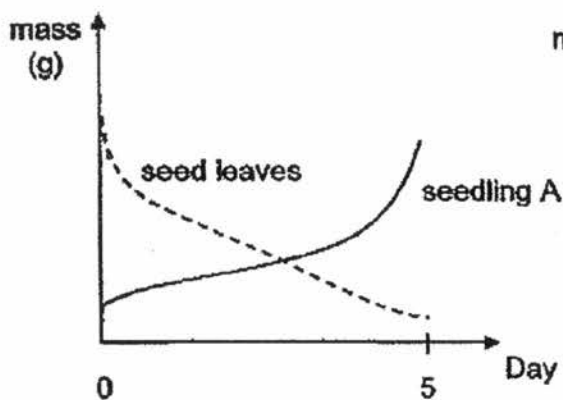

graph A

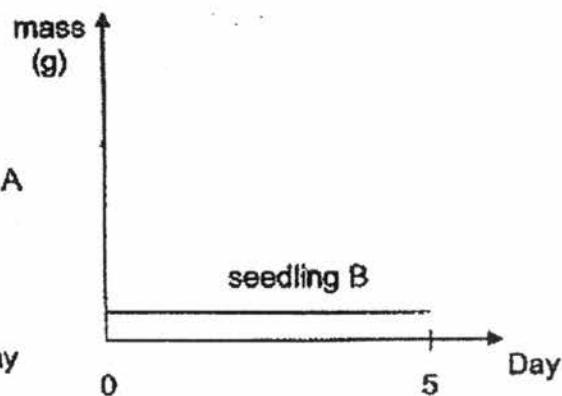

graph B

Based on the graphs, what can you conclude about the growth of the seedlings?

- (1) The seedlings do not depend on the seed leaves for its growth.
- (2) The seedlings start to make its own food once the shoots appear.
- (3) The roots will grow downwards first before the shoots start to grow upwards.
- (4) The mass of the seed leaves of seedling A decreases as the seedling continues to grow.

9. Benny carried out an experiment using 2 similar flowers, X and Y, of the same plant as shown below. He removed some parts of the 2 flowers. He then transferred some pollen grains from another flower of the same plant to the remaining parts of each flower. After that, he observed if fruits were formed.

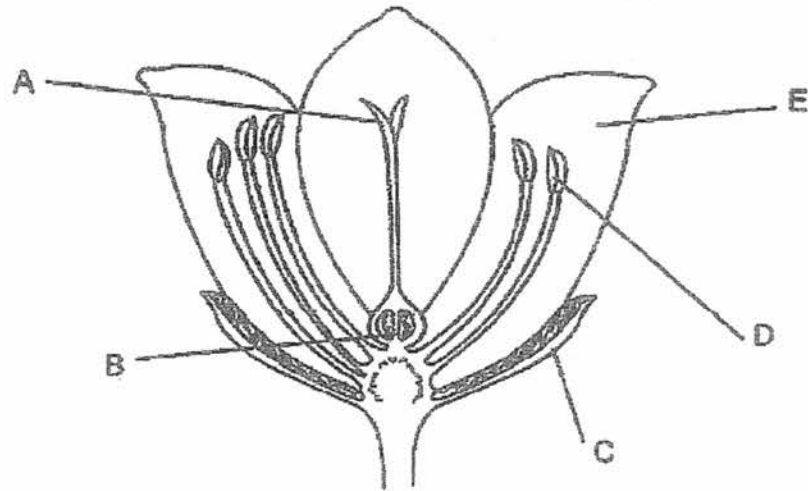

The results of the experiment are shown below.

Flower	Did it develop into a fruit?
X	NO
Y	Yes

Which of the following shows the parts of the flowers that have been removed?

Parts removed	
Flower X	Flower Y
(1) A and E	C, D and E
(2) C and D	A, B and C
(3) D and E	C and D
(4) C, D and E	B and C

10. Study the diagram below carefully. The diagram can be used for both the human and the plant reproductive systems.

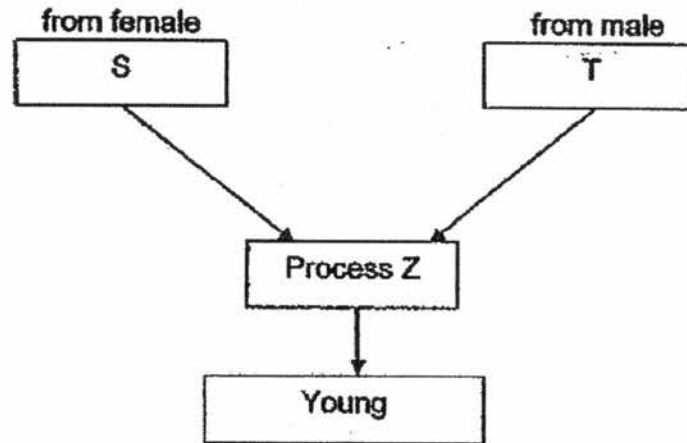

Which of the following correctly represents S, T and process Z in both the human and the plant reproductive systems?

	Human reproductive system			Plant reproductive system		
	S	T	Process Z	S	T	Process Z
(1)	Ovary	Testis	Fertilisation	Stigma	Anther	Pollination
(2)	Egg	Sperm	Pollination	Ovule	Pollen grain	Pollination
(3)	Egg	Sperm	Fertilisation	Ovule	Pollen grain	Fertilisation
(4)	Egg	Sperm	Fertilisation	Egg	Male Sex Cell	Fertilisation

11. Casey was stuck in a lift with a group of people for 30 minutes when it stopped working. The fan was not working and the lift door was tightly shut.

In the tables below, what is the most likely changes in the amount of oxygen, carbon dioxide, nitrogen and water vapour in the lift after 30 minutes?

(1)

Gas	Changes
Oxygen	Decrease
Carbon dioxide	Increase
Nitrogen	No change
Water vapour	No change

(2)

Gas	Changes
Oxygen	Decrease
Carbon dioxide	Increase
Nitrogen	Increase
Water vapour	No change

(3)

Gas	Changes
Oxygen	Increase
Carbon dioxide	Decrease
Nitrogen	No change
Water vapour	Decrease

(4)

Gas	Changes
Oxygen	Decrease
Carbon dioxide	Increase
Nitrogen	No change
Water vapour	Increase

12. The diagram below shows the direction of blood flow indicated by arrows A, B, C and D, in the human circulatory system.

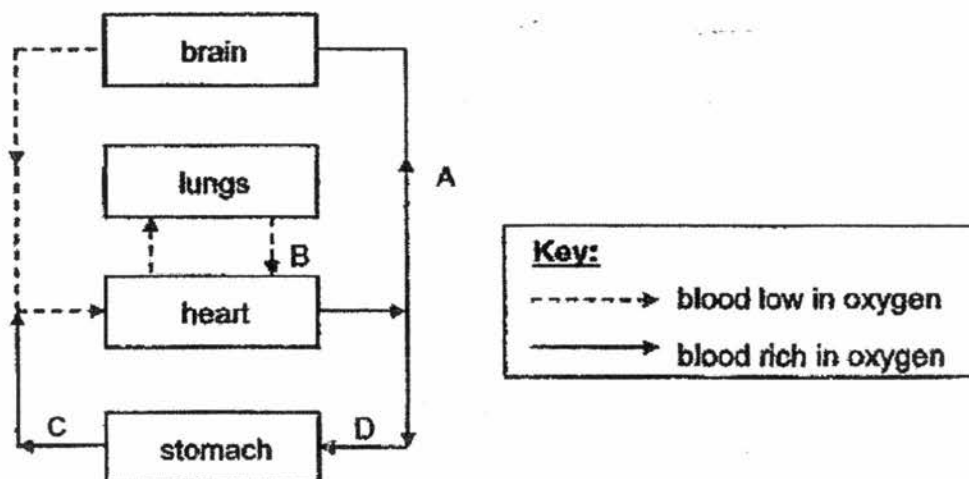

Which two arrows were not drawn correctly?

- (1) A and B
 (2) B and C
 (3) C and D
 (4) A and D
13. Joseph observed two cells using a microscope and recorded his observations in the table below. A tick (✓) indicates the presence of the cell part.

Cells	Nucleus	Chloroplasts	Cell Wall	Cytoplasm	Cell Membrane
R	✓	✓	✓	✓	✓
S	✓		✓	✓	✓

From the information above, what can be inferred about cells R and S?

- (1) Both cell R and cell S are plant cells.
 (2) Both cell R and cell S can make food.
 (3) Cell S has a regular shape but not cell R.
 (4) Cell R is a plant cell and cell S is an animal cell.

14. John conducted an experiment on photosynthesis. He left 3 similar pots of plants in a dark room for 3 days and watered them daily.

After 3 days, he placed the plants in set-ups X, Y and Z containing different substances as shown below and left them under strong sunlight.

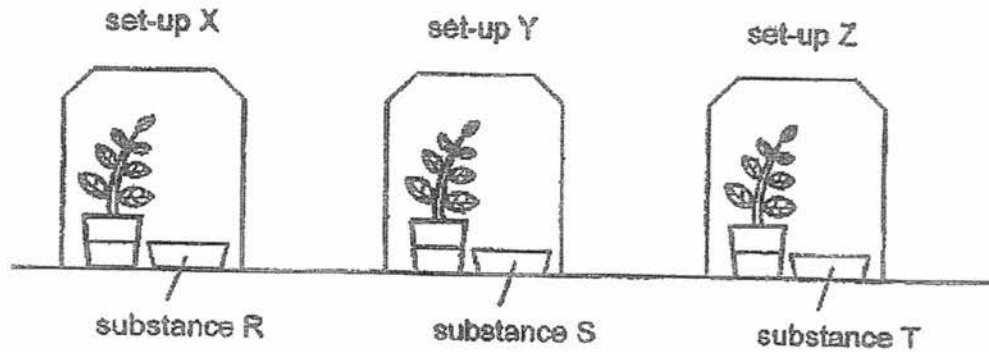

After 5 hours, John removed a leaf from each set-up and drip some iodine solution on each of them. The observations are shown in the table below.

Leaf from set-up	Observation
X	Iodine solution turned dark blue
Y	Iodine solution remained yellowish brown
Z	Iodine solution turned dark blue

Which of the following is most likely to be substances R, S and T?

	Substance R	Substance S	Substance T
(1)	water	substance that absorbs carbon dioxide	substance that produces carbon dioxide
(2)	substance that absorbs carbon dioxide	water	substance that absorbs oxygen
(3)	substance that produces carbon dioxide	substance that absorbs oxygen	water
(4)	water	substance that produces carbon dioxide	substance that produces oxygen

15. The diagram below shows the digestive system of a human body.

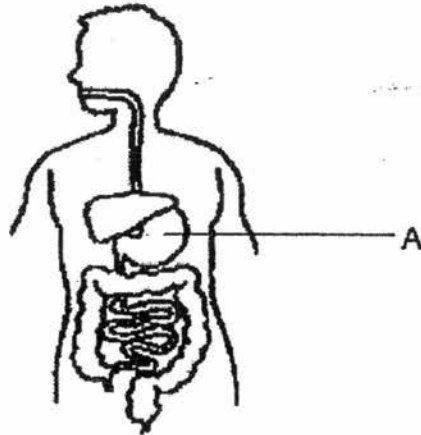

Michael has to reduce his mass as he is severely obese. The doctors suggested that he goes through an operation to tie up his organ A to reduce its size.

How does this help to reduce Michael's mass?

- (1) To reduce the amount of food that can be digested.
- (2) To reduce the amount of water that can be digested.
- (3) To increase the amount of food that can be digested.
- (4) To increase the amount of water that can be digested.

16. Study the diagrams below.

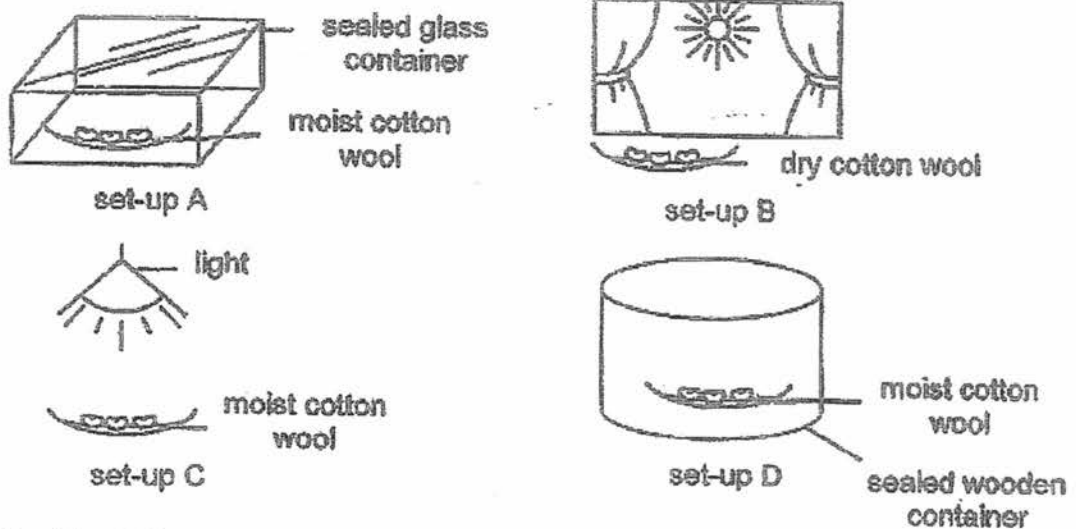

Which of the following set-up(s) will the seeds germinate?

- (1) B only
- (2) B and C only
- (3) A, B and C only
- (4) A, C and D only

17. The diagram below shows the young of a cockroach and a butterfly.

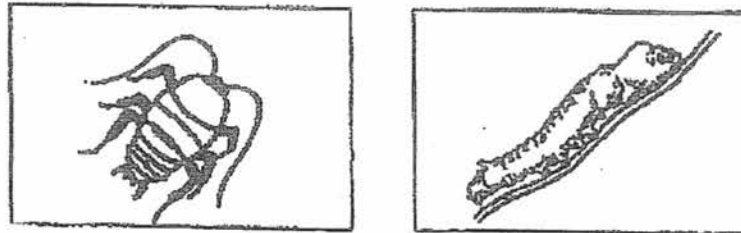

Which of the following statement(s) correctly describe(s) the difference between the life cycle of the cockroach and the butterfly?

- A The cockroach reproduces by laying eggs but the butterfly gives birth.
- B The cockroach has a three-stage life cycle but the butterfly has a four-stage life cycle.
- C The young of the butterfly does not resemble the parent but the young of the cockroach does.

- (1) A only
- (2) B only
- (3) B and C only
- (4) A, B and C

18. Four pupils, Ali, Ben, Carl and Deanna, were told to set up a circuit that could test if the batteries are flat. The ticks (✓) in the table below show the electrical parts that each pupil has chosen for their own circuits.

Pupil	Bell	Bulb	Wires	Switch	Battery
Ali		✓	✓	✓	✓
Ben		✓	✓		
Carl		✓		✓	✓
Deana	✓		✓		✓

Which pupil(s) has/have chosen the correct electrical parts for their circuit?

- (1) Ali only
- (2) Ben and Carl only
- (3) Ali and Deana only
- (4) Carl and Deana only

19. Which of the following statements explain why we have to use electricity wisely?

- A Generating electricity is costly.
- B The supply of fossil fuels is unlimited.
- C Fossil fuels cannot be replaced easily.
- D Burning fossil fuels to generate electricity will give off harmful gases.

- (1) A and B only
- (2) C and D only
- (3) A, C and D only
- (4) A, B, C and D

20. Tommy designed a system whereby pure water is obtained from salt water.

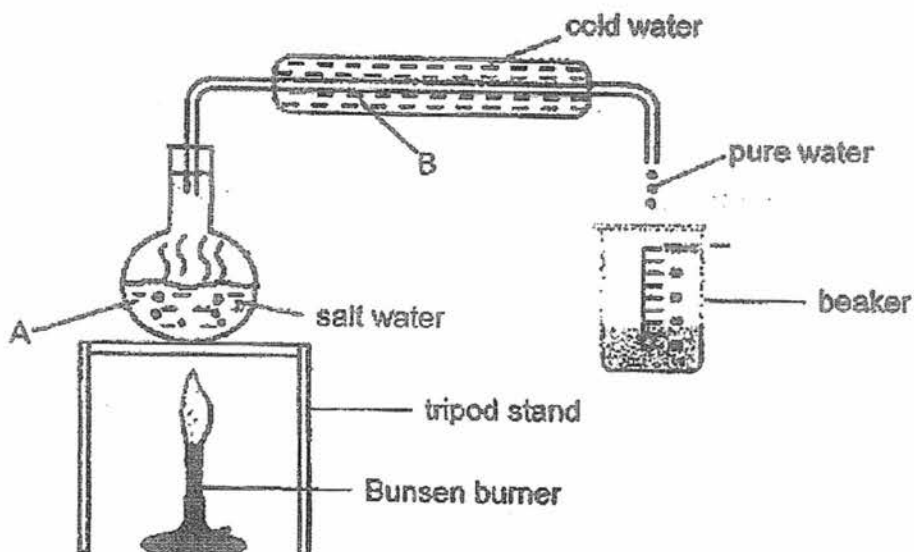

The salt water undergoes two processes. Name the processes taking place at A and B.

	A	B
(1)	Boiling	Condensation
(2)	Boiling	Evaporation
(3)	Evaporation	Condensation
(4)	Evaporation	Boiling

21. Mandy heated up a beaker of water until it reached the boiling point. She then removed the beaker from the heat source and placed the beaker of water in a well-ventilated room. She took note of the changes in the temperature of the water in the beaker for 20 minutes and plotted the graph with the values taken.

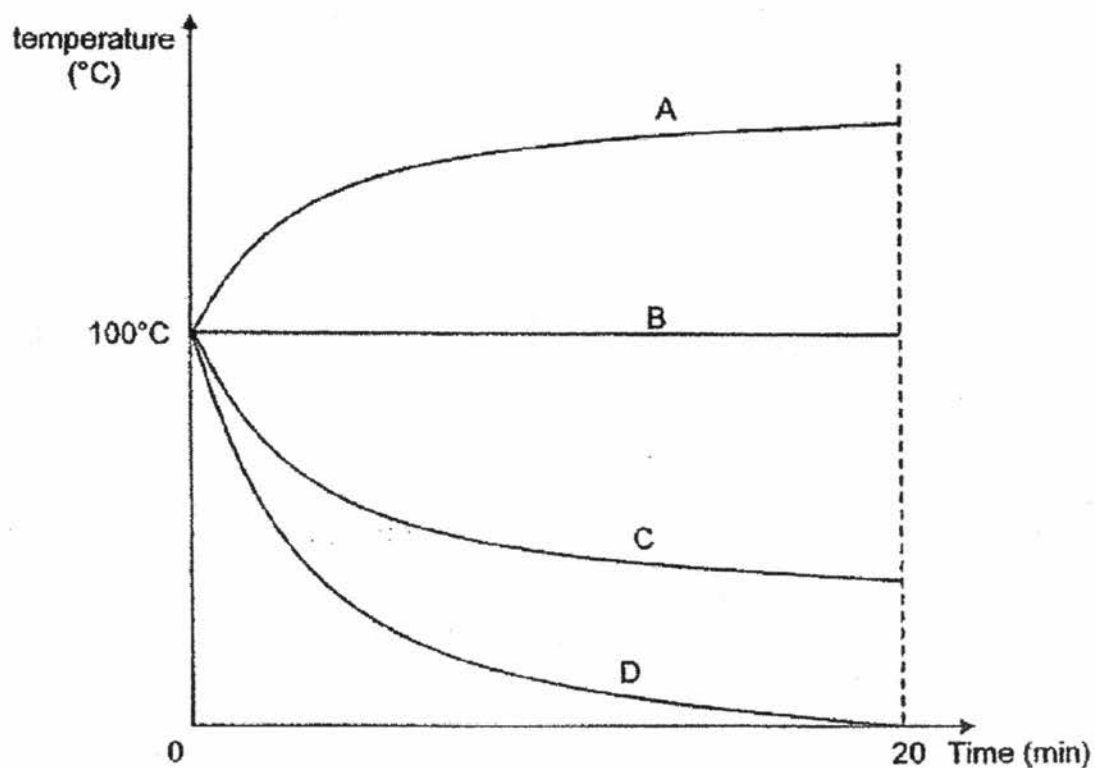

Which one of the following line graphs correctly shows the changes in the temperature of the water?

- (1) A
- (2) B
- (3) C
- (4) D

22. Jamie prepared a set-up as shown in the diagram below.

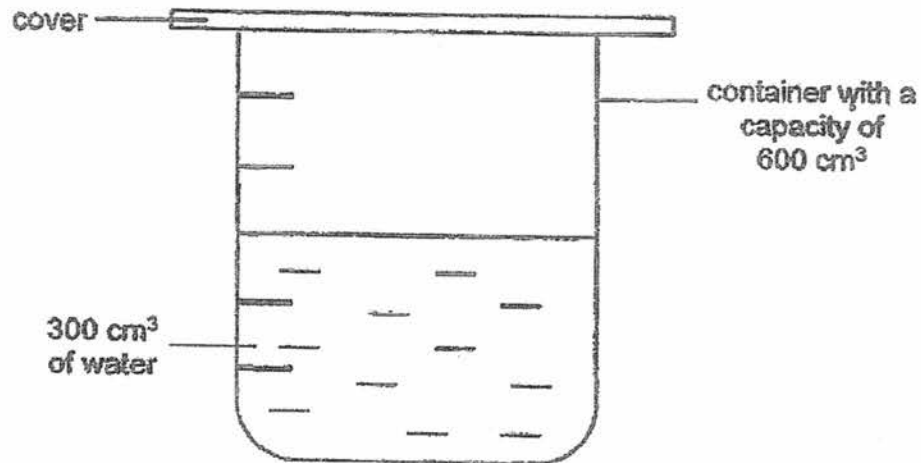

She then poured 50 cm³ of marbles into the container and pumped in 100 cm³ of air into the container and sealed it.

Which of the following statement(s) is/are possible observations made by her?

- A The mass of the set-up will not change.
- B The total volume of air in the set-up will increase.
- C The total volume of water in the set-up will increase.
- D The marbles will take up 50 cm³ of space in the set-up.

- (1) D only
- (2) A and C only
- (3) A, B and D only
- (4) B, C and D only

23 Jason wanted to find out the best way to cook soft-boiled eggs.

He conducted an experiment with the following 4 set-ups as shown in the picture below. 4 identical eggs were left in each beaker for 5 minutes. After 5 minutes, the eggs were taken out and cracked to see how cooked each of the egg was.

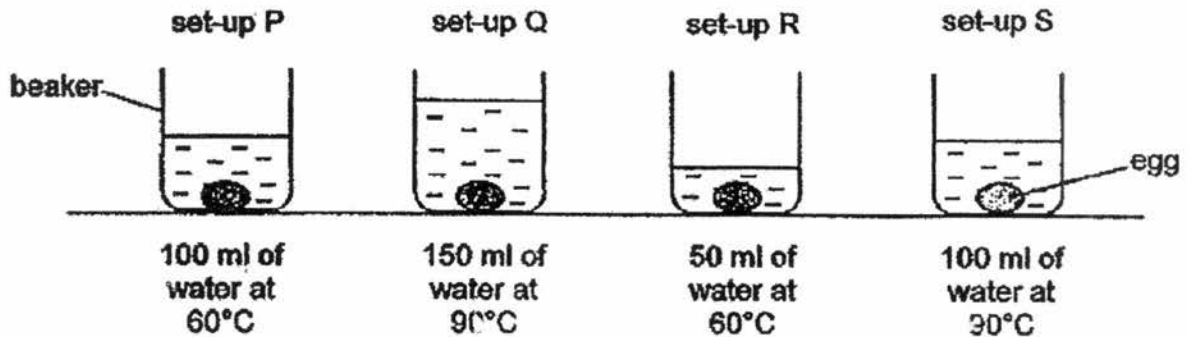

Which one of the following shows the correct arrangement of the set-ups starting with the egg that was most cooked to the egg that was least cooked?

- (1) R, P, S, Q
- (2) S, P, Q, R
- (3) Q, S, P, R
- (4) P, R, Q, S

24. The diagram below shows an iron nail that was freely suspended in between electromagnet X and electromagnet Y.

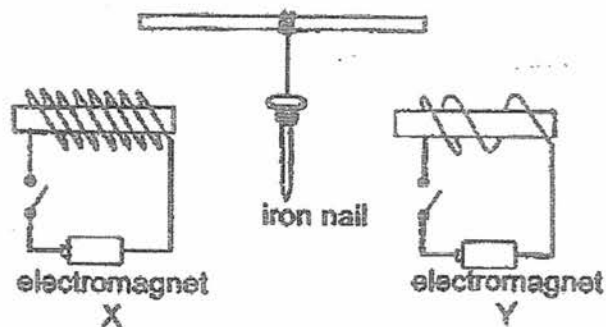

If both circuits are closed, what will happen to the iron nail?

- (1) The iron nail will swing from side to side.
- (2) The iron nail will remain at the same position.
- (3) The iron nail will move towards electromagnet X.
- (4) The iron nail will move towards electromagnet Y.

25. What happens when the ice cubes in the container are melting?

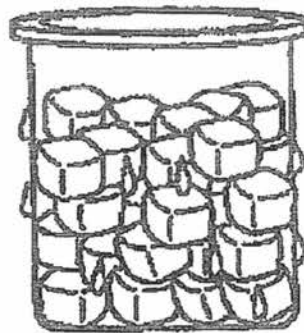

- A The ice cubes lose heat.
- B The ice cubes gain heat.
- C The ice cubes change into a gaseous state.
- D The temperature of the ice cubes rises to room temperature.

- (1) B only
- (2) A and C only
- (3) B and D only
- (4) B, C and D only

26. Xavier set up two electrical circuits, P and Q, as shown below. The bulbs and batteries used were identical. All the bulbs lighted up when the switches were closed.

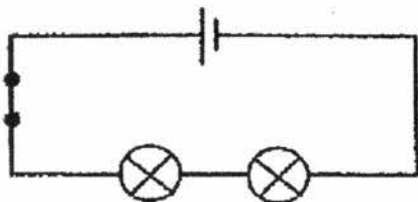

circuit P

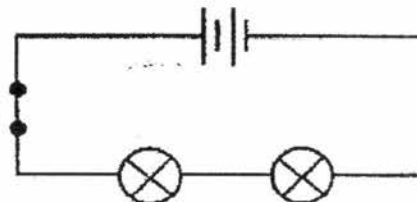

circuit Q

What variables must he keep constant if he wants to find out if the number of batteries will affect the brightness of the bulb?

- A The number of bulbs.
- B The number of batteries.
- C The brightness of the bulbs.
- D The arrangement of the bulb.

- (1) A and C only
- (2) A and D only
- (3) B and C only
- (4) A, C and D only

27. Faith set up the experiment below to find out if liquid P is a conductor of electricity. The nichrome wire will turn red and heat up when electric current passes through it in a closed circuit.

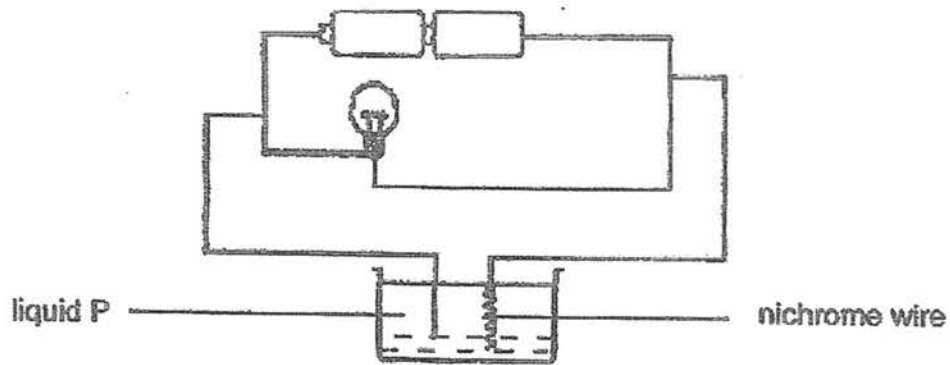

Which of the following will help Faith to conclude that liquid P is a conductor of electricity?

- A The bulb lights up.
- B The nichrome wire turns red.
- C The temperature of liquid P rises.

- (1) A only
- (2) A and B only
- (3) B and C only
- (4) A, B and C

28. All the bulbs in the circuit below light up when all the switches are closed. Elaine made following statements.

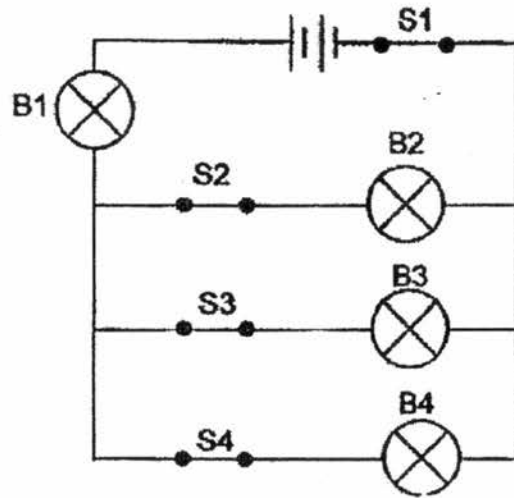

- A When S4 is opened, B1, B2 and B3 will light up.
B S1 can be used to control all the bulbs in the circuit.
C When B1 is fused, the rest of the bulbs can still light up.
D When B3 is fused, the rest of the bulbs can still light up.

Which of her statement(s) is/are true?

- (1) C only
(2) A and D only
(3) A, B and C only
(4) A, B and D only



NAN HUA PRIMARY SCHOOL
SEMESTRAL ASSESSMENT 2 – 2017
PRIMARY 6

SCIENCE

BOOKLET B

12 Open-ended questions (44 marks)

Total Time for Booklets A and B : 1 hour 45 minutes

INSTRUCTIONS TO CANDIDATES

1. Write your name and index number in the space provided.
2. Do not turn over the page until you are told to do so.
3. Follow all instructions carefully.
4. Answer all questions.
5. Write your answers in this booklet.

Marks Obtained

Section B	144
-----------	-----

Name: _____ () Class: P 5 _____

Date : 31 October 2017

Parent's Signature: _____

Section B: (44 marks)

Write your answers to questions 29 to 40. The number of marks available is shown in brackets [] at the end of each question or part-question.

29. Cindy created a classification chart as shown below. The classification chart shows the substances that are transported by the plant transport system and the human circulatory system.

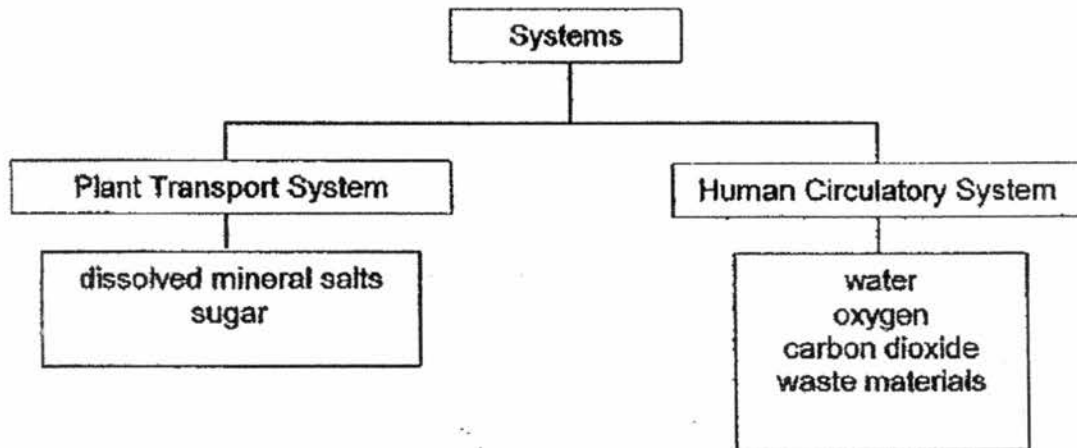

- (a) There are two missing substances in the chart above. Fill in the missing substances in the table below. [2]

System	Missing substance
Plant Transport System	
Human Circulatory System	

- (b) Name an organ that is found in the human circulatory system that enables blood to flow continuously through the blood vessels around the body. [1]

- (c) What will happen to a plant if all the food-carrying tubes are removed? Explain your answer [1]

Score	4
-------	---

30. Zoe immersed a cell in a solution with substances X, Y and Z.

After some time, she found the substances at different parts of the cells as shown below.

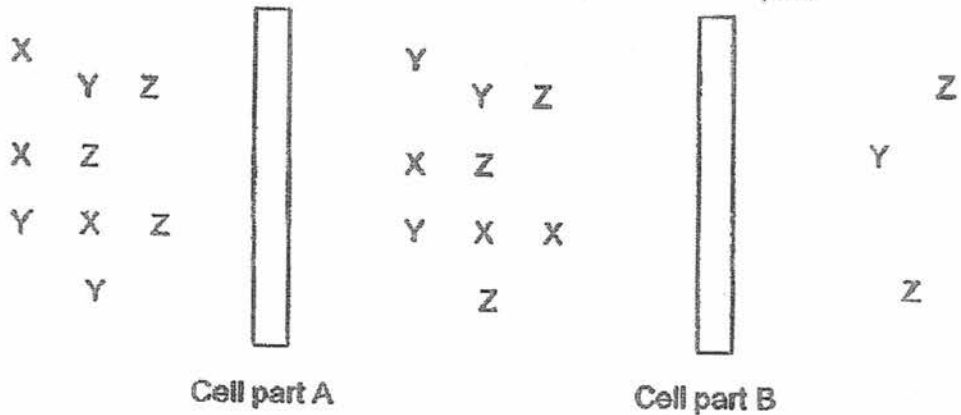

(a) From the diagram above, identify Cell part A and Cell part B. [1]

Cell part A: _____

Cell part B: _____

(b) Explain your answer in (a). [1]

Score	2
-------	---

31. Peter recently set up a fish tank in his house beside a window.

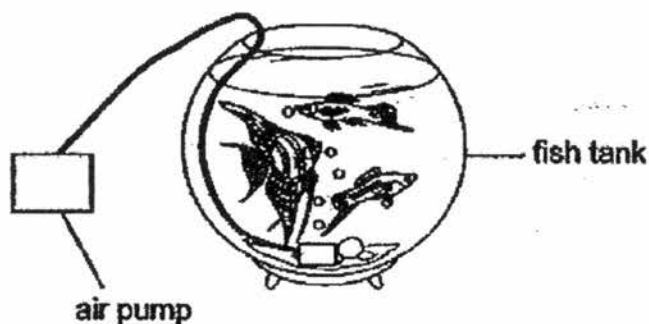

Peter then left for a 2-week overseas work trip. Before he left for the trip, he had cleaned the tank and made sure that the fish were healthy. When he came back, he found that all his fish had died.

(a) Explain why his fish had died. [1]

Peter then added in some new fish and plants into the fish tank. When he came back from his second 2-week overseas work trip, he found that all the fish survived and his plants have grown taller.

(b) Give a possible reason why his fish are able to survive this time round. [1]

(c) What causes the plant to grow taller? [1]

Score	3
-------	---

32. Lily wanted to find out if seeds need warmth to germinate. She placed six seeds in each of the two containers which were filled with equal amount of moist cotton wool. She then placed one of the containers in her room.

(a) Suggest where she should place the other container in order for her to conduct her experiment. Explain clearly why. [2]

(b) Based on your answer in (a), what observation would enable her to conclude that seeds need warmth to germinate? [1]

(c) Name two other variables that seeds need in order to germinate. [1]

Score	4
-------	---

33. Laura wanted to investigate how the intensity of light affects the rate of photosynthesis of aquatic plant X.

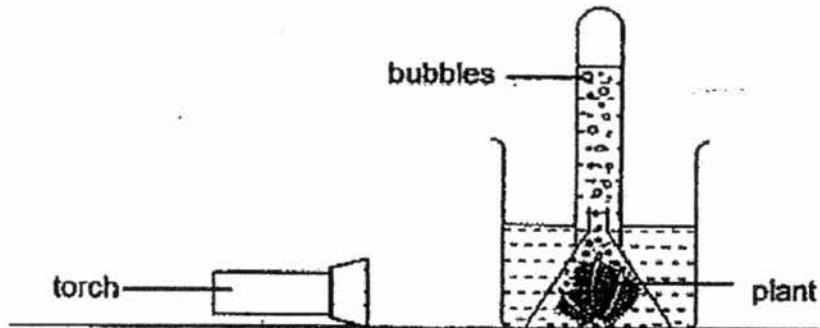

She set up 4 similar set-ups as shown above using torches of different light intensities, 20 lux, 60 lux, 100 lux and 140 lux, in a dark room. She counted and recorded the number of bubbles observed in each set-up over a period of 15 minutes.

Light intensity of torch (lux)	Number of bubbles
20	10
60	20
100	A
140	50

- (a) What could be a possible value for A? [1]

- (b) What is the relationship between light intensity and the rate of photosynthesis? [1]

- (c) Laura changed the plant to one which has more leaves and observed that the number of bubbles produced increased. Explain this observation. [2]



34. Mark prepared the set-ups shown below using different materials of equal thickness. He used identical beakers containing the same amount of water at 100°C .

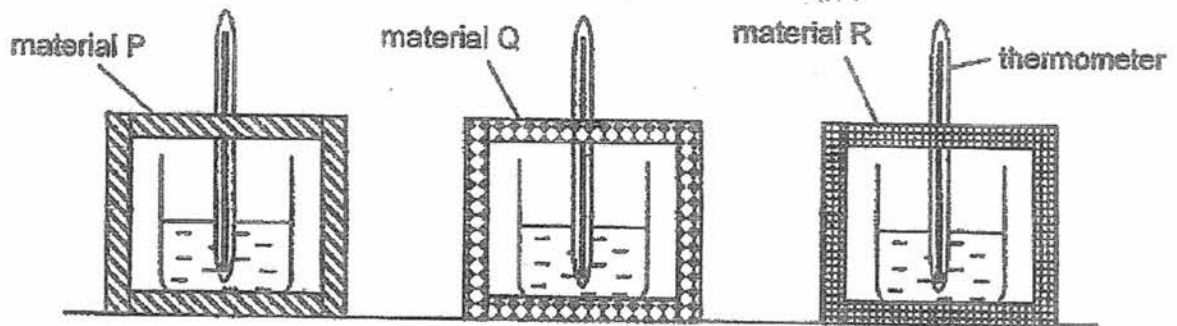

He measured and recorded the temperature of water in each beaker at regular intervals using a thermometer. The graph below shows the results of the experiment.

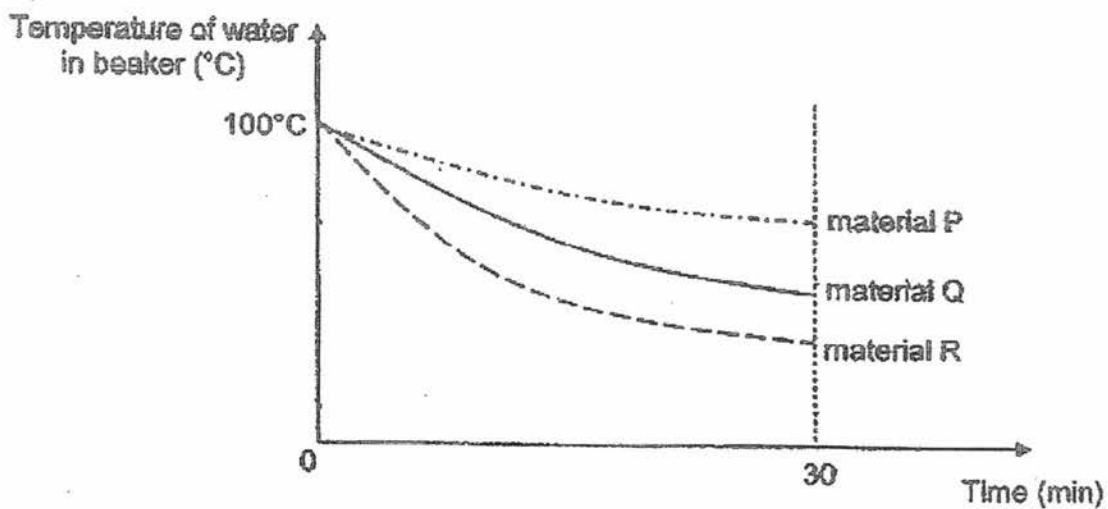

- (a) Give a reason why the thickness of materials P, Q and R must be kept the same in order to ensure a fair test. [1]

- (b) Arrange the materials, P, Q and R, according to their heat conductivity. Write your answers in the boxes below.

[1]

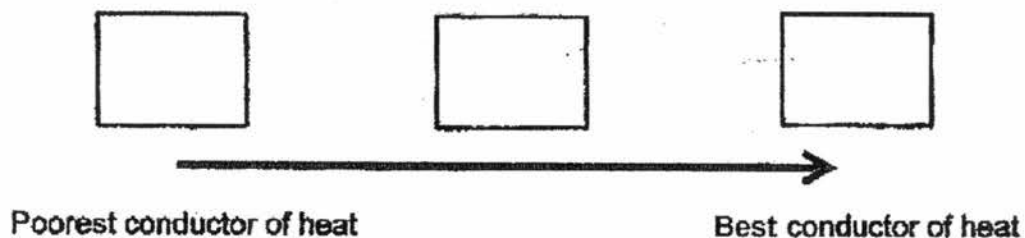

- (c) Which material, P, Q or R, is the most suitable material for making a container to keep ice-cream frozen for the longest time? Explain your answer clearly.

[2]

- (d) What can Mark do to improve on the reliability of the experiment?

[1]

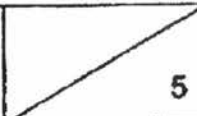
Score	
-------	---

35. Huishan connected a circuit as shown in the diagram below.

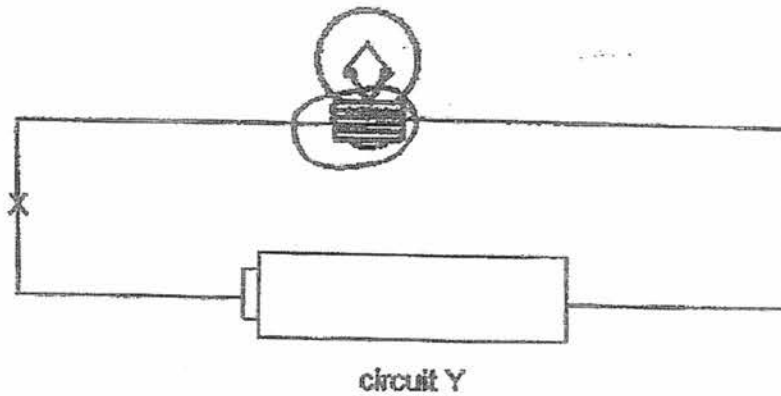

(a) Explain why the bulb does not light up in circuit Y? [1]

(b) Huishan made the changes in circuit Y to ensure that the bulb will light up and then added a switch at position X.

What will happen when the switch is closed? Explain the function of the switch. [1]

Score	2
-------	---

- 36 Fred made a circuit maze with strips of paper on a cardboard as shown below. The four corners labelled W, X, Y and Z are made of aluminium foil.

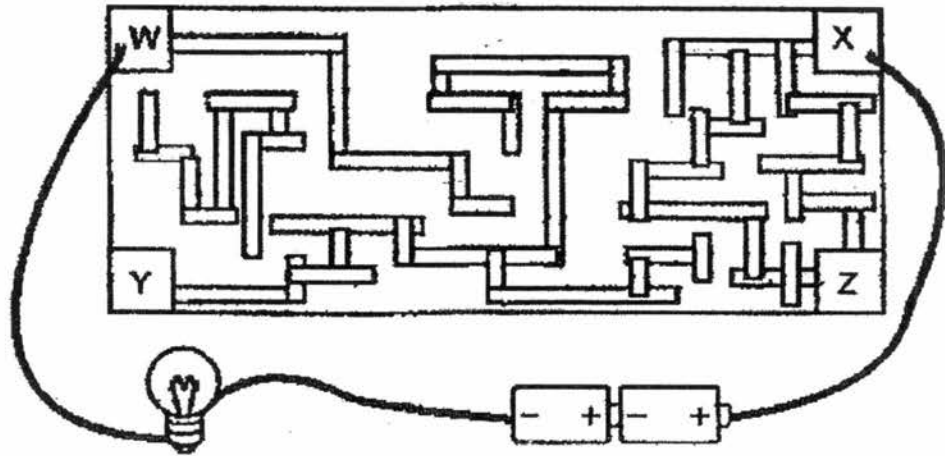

- (a) When he tried testing the circuit maze, the bulb did not light up. Why did the bulb not light up? [1]

- (b) What is a possible solution for Fred to solve the problem? [1]

- (c) When Fred had fixed the problem, which two corners should Fred connect the wires with so that the bulb will light up? Explain. [2]

Score	4
-------	---

- 37 Wei Liang set up the 2 set-ups as shown below to investigate if the number of batteries in the circuit will affect the temperature of the water. The batteries, wires and the nichrome wire used are identical.

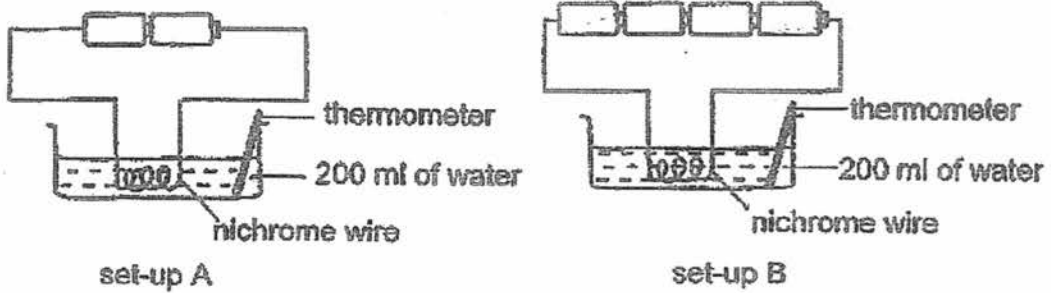

- (a) From the set-ups above, what is the variable that is changed? [1]

- (b) What are the two constant variables that Wei Liang needs to maintain? [2]

- (c) What are two observations that Wei Liang can make at the end of the experiment to conclude his experiment? [2]

Score	5
-------	---

- 38 The diagram below shows how Mrs Lim and Mrs Tan hung two similar T-shirt to dry.

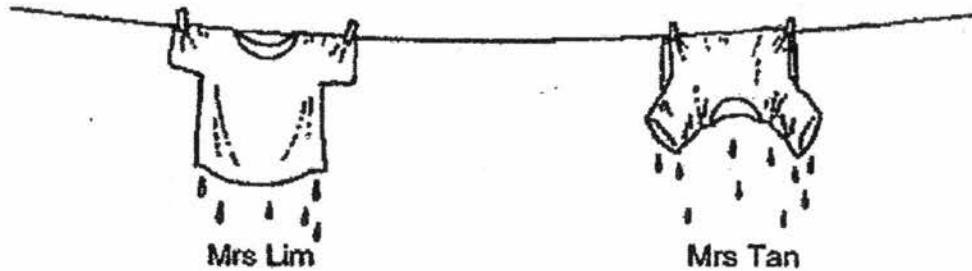

- (a) Whose T-shirt will take a longer time to dry? Explain your answer. [2]

- (b) Tim came out of the cold shower without drying himself well. When he opened the door of the toilet, he felt very cold.



- Explain why Tim felt cold when he left the toilet. [2]

Score	4
-------	---

39 Study the diagram below.

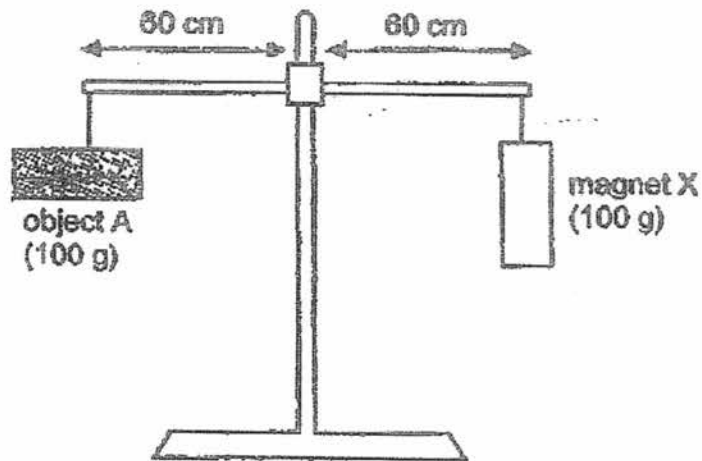

When object B is moved towards magnet X, the lever continued to be balanced as shown below.

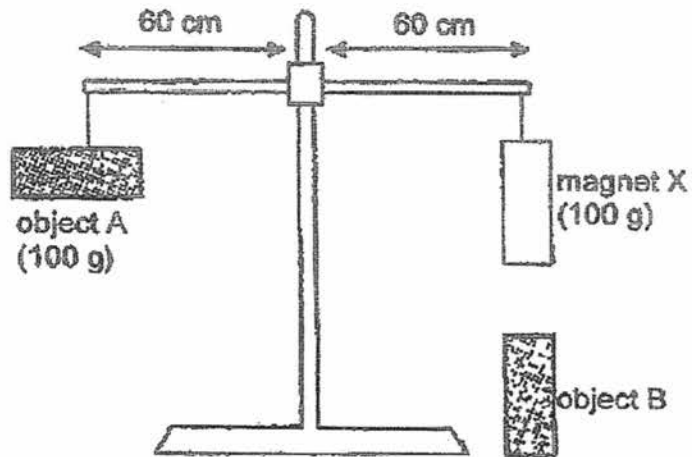

- (a) Based on the observation above, identify a property of object B. Give a reason for your answer. [2]

- (b) When object B was replaced with object C. The lever was no longer balanced. Position of magnet X is now higher than object A.

What could object C be? Explain your answer.

[2]

Score	4
-------	---

40. Jessica poured equal amounts of liquids W and X at room temperature into 2 similar containers, A and B. The containers were placed in the freezer for 12 hours. The temperature of the freezer is 0°C .



After 12 hours, she took out the containers and immediately tilted the containers as shown in the diagram below.

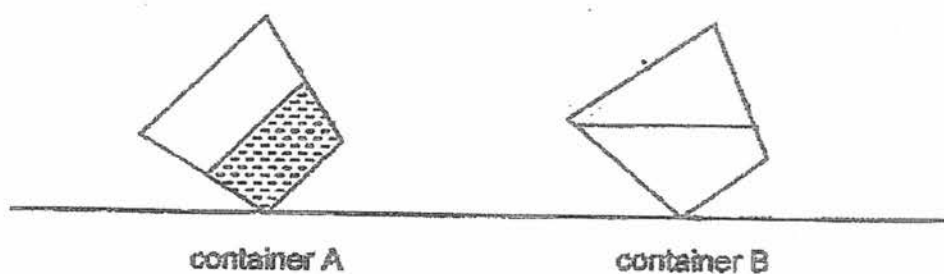

- (a) Based on what you observe from the experiment above, what can Jessica conclude about the freezing point of liquid X? [1]

The diagram below shows 2 ice packs. An ice pack could be placed on the forehead of the user to bring down the temperature when a person is having a fever. The user will place the ice pack into a freezer which is 0°C overnight first before placing it on the forehead.

In the diagram below, ice pack P is purchased from the shop. Ice pack Q is homemade using water.

Freezing temperature of liquid
in ice pack is below 0°C



ice pack P

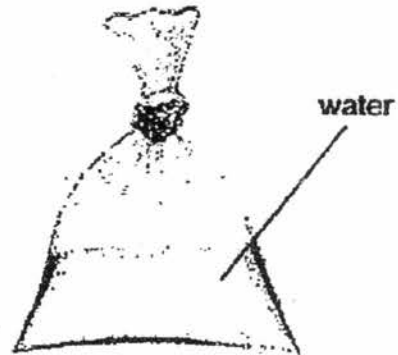

ice pack Q

- (b) Based on the above information, explain clearly which ice pack would be a more comfortable choice to use. [2]

End of Paper

Score	3
-------	---

EXAM PAPER 2017 (P5)

SCHOOL : NAN HUA

SUBJECT : SCIENCE

TERM : SA2

Q1	Q2	Q3	Q4	Q5	Q6	Q7	Q8	Q9	Q10
2	2	4	1	2	1	2	4	1	4
Q11	Q12	Q13	Q14	Q15	Q16	Q17	Q18	Q19	Q20
4	2	1	1	1	4	3	3	3	1
Q21	Q22	Q23	Q24	Q25	Q26	Q27	Q28		
3	1	3	3	1	2	3	4		

29)a)

	Water
	Digested food

b)Heart.

c)The plant will die. Food made by the leaves cannot be transported to other parts of the plants to perform respiration.

30)a)Cell part A: cell wall

Cell part B: cell membrane

b)Cell part A allows all the substance to pass through but cell part B allow only substance Y and Z to pass through.

31)a)The lack of food and the cleanliness of the water.

b)The fish fed on the plants.

c)The plants photosynthesized in the presence of light and carbon dioxide.

32)a)She should place it in the refrigerator. She wanted to find out if seeds need warmth to germinate so she needed to place the second container in a place where there is no warmth.

b)She should observe that only the seeds in the container in her room germinated.

c)water and oxygen.

33)a)40.

b)The light intensity increases the rate of photosynthesis increases.

c)With more leaves the plant is able to trap more energy to make more food. More bubbles will be produced as more oxygen will be released by the plant through photosynthesis.

34)a)It is so that the thickness of the materials will not affect the rate which heat is conducted from inside the container to the outside.

b)P Q R

c)Material P. The water in the beaker with box made from material P has highest temperature at the end of the experiment Material P is the poorest conductor of heat. So, the ice cream will gain heat slowest from the surrounding to melt.

d)Mark could repeat the experiment a few times.

- 35) a) The metal tip of the bulb was not connected causing an open circuit.
b) The bulb will light up. The switch helps to open and close a circuit.
- 36) a) The strips of paper are electrical insulators and causes an open circuit.
b) Replace the paper strips with aluminium strips.
c) X and Z. There is a completed path for electricity to flow to ensure a close circuit.
- 37) a) The numbers of batteries.
b) Amount of water in the container at the start temperature of water in the container at start.
c) The time taken for the water to reach boiling point.
The temperature of the water after is minutes.
- 38) a) Mrs Tan's shirt the T-shirt has lesser exposed surface area causing a lower rate of evaporation.
b) The water on his body gain heat from him and evaporate into water vapour.
- 39) a) Object B is a non-magnetic material, as it did not attract or repel from magnet X. Thus it concludes that object B is not a magnetic material.
b) Object C is a magnet. The like poles of magnet X and object C are facing each, causing them to repel.
- 40) a) Liquid X freezing point is belong 0°C .
b) Ice pack P. The liquid in ice pack P will not be frozen. The ice pack will be place more fittingly on the forehead as it can warp around the forehead . The water in ice pack Q will be frozen into ice.