

METHODIST GIRLS' SCHOOL

Founded in 1887



MID-YEAR EXAMINATION 2019

PRIMARY 5

SCIENCE

BOOKLET A

Total Time for Booklets A and B: 1 hour 45 minutes

INSTRUCTIONS TO CANDIDATES

Do not turn over this page until you are told to do so.

Follow all instructions carefully.

Answer all questions.

Shade your answers in the Optical Answer Sheet (OAS) provided.

Name: _____ ()

Class: Primary 5. _____

Date : 14 May 2019

This booklet consists of 20 printed pages including this page.

For each question from 1 to 28, four options are given. One of them is the correct answer. Make your choice (1, 2, 3 or 4). Shade the correct oval on the Optical Answer Sheet (OAS).
[56 marks]

- 1 Tim prepared four set-ups, A, B, C and D, as shown in the diagram below.

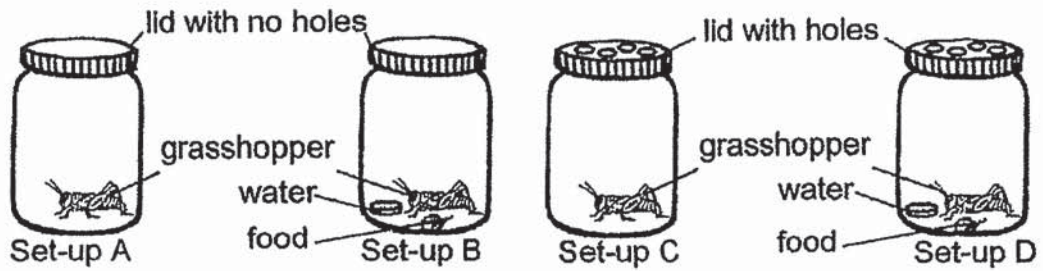

Which two set-ups should Tim choose to find out whether a grasshopper needs air to survive?

- (1) A and B
- (2) A and C
- (3) B and D
- (4) C and D

(Go on to the next page)

- 2 The table below shows information about three plants, S, T and U. A tick (✓) shows that the plant has the characteristic.

Plants	S	T	U
Characteristics			
Reproduce by spores	✓		
Grow on water		✓	

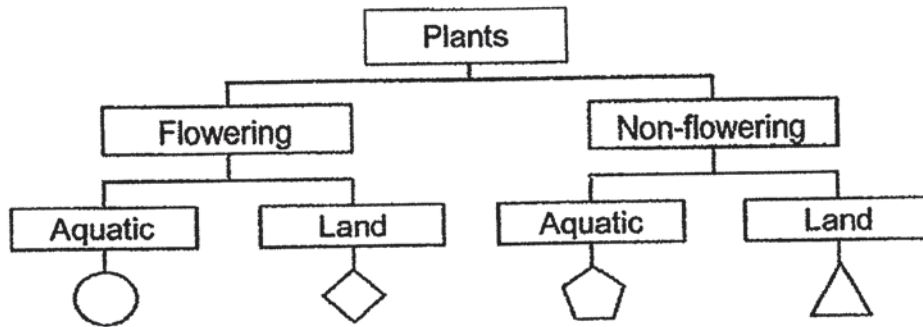

From the information given above, which of the following symbols best represent plants S, T and U in the classification chart?

	Plant S	Plant T	Plant U
(1)	△	○	◇
(2)	◇	⬠	○
(3)	○	△	◇
(4)	△	○	⬠

(Go on to the next page)

- 3 The flow chart below shows how animals, A, B, C, and D are classified.

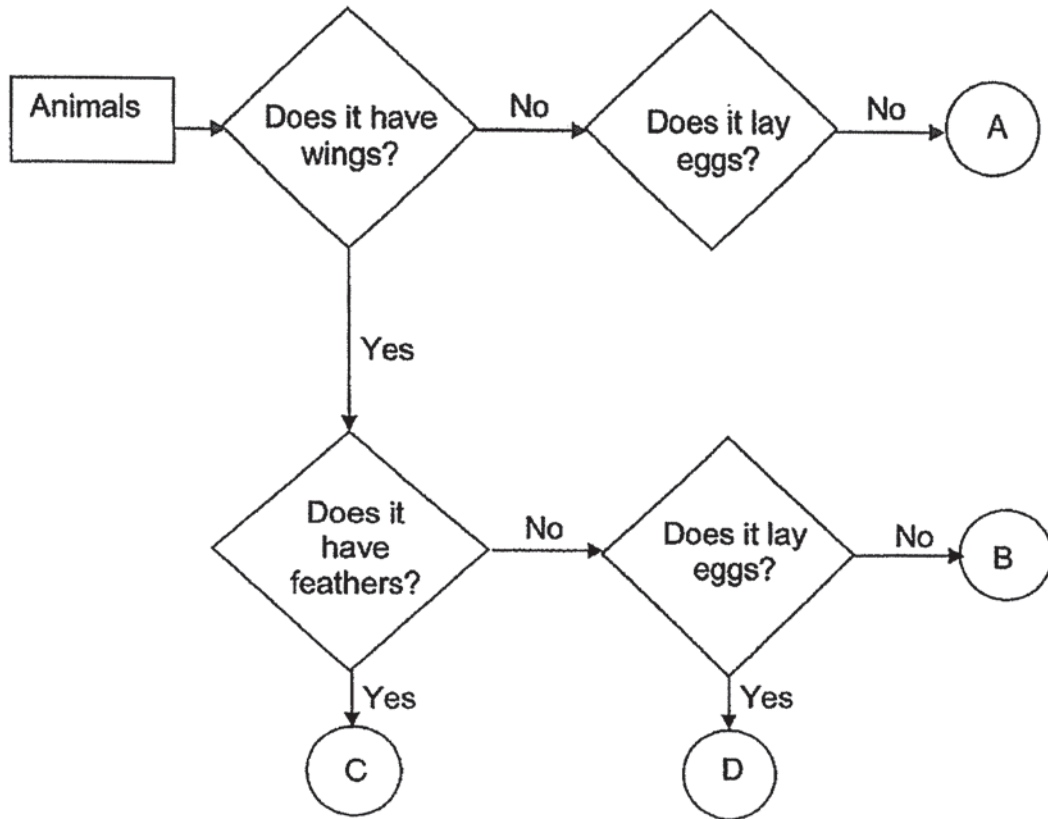

Which of the following represent animals A, B, C and D in the flow chart?

	Animal A	Animal B	Animal C	Animal D
(1)	guppy	bat	parrot	butterfly
(2)	bat	ant	penguin	butterfly
(3)	ostrich	bat	penguin	parrot
(4)	guppy	butterfly	parrot	bat

(Go on to the next page)

- 4 James wanted to investigate the suitable conditions for fungi to grow. He prepared four identical set-ups each in a sealed plastic bag and placed them in different locations.

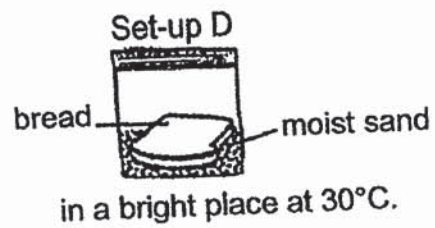
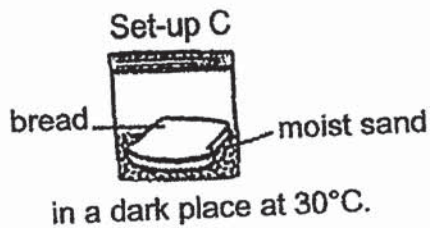
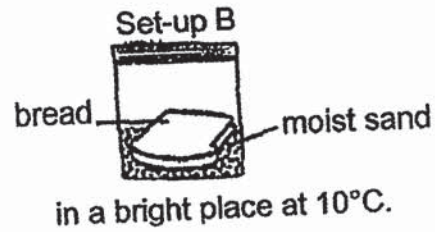
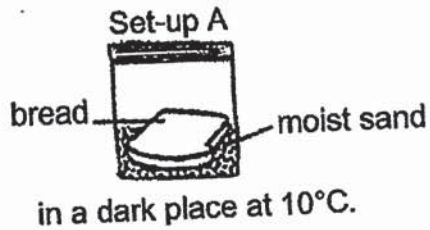

After three days, fungi were seen growing in set-ups C and D but not in set-ups A and B.

From this experiment, James concluded that fungi _____.

- (1) need light to grow
- (2) need water to grow
- (3) grow in a dark place
- (4) grow in a warm place

(Go on to the next page)

- 5 Raju wanted to find out how overcrowding can affect the growth of plants. He prepared five set-ups as shown in the table below.

Set-up	Type of seeds	Number of seeds	Conditions		
			air	warmth	water
A	green bean	5	air	warmth	water
B	red bean	5	air	warmth	water
C	broad bean	5	no air	no warmth	water
D	green bean	35	no air	no warmth	water
E	red bean	35	air	warmth	water

Which of the following set-ups should he choose to compare the results?

- (1) A and C
 - (2) B and E
 - (3) C and E
 - (4) C and D
- 6 Look at the diagram below.

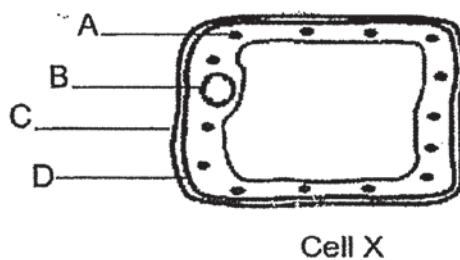

Which part of Cell X has the same function as the skeleton?

- (1) Part A
- (2) Part B
- (3) Part C
- (4) Part D

(Go on to the next page)

- 7 Two types of wire, A and B, of the same length were compared. When straightened, wire B measured longer as shown in the diagram below.

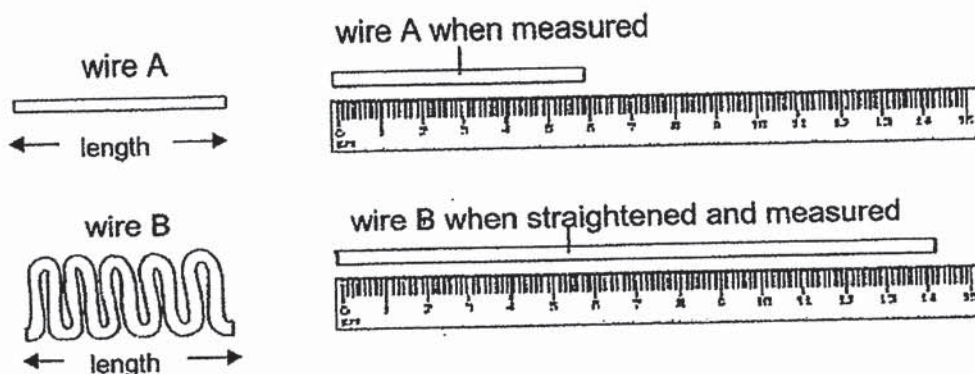

Wire B resembles part of the finger-like structures found in the small intestine as shown below.

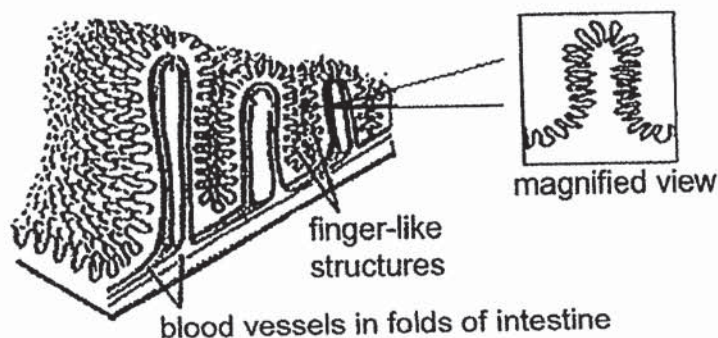

Which of the following statement(s) is/are correct?

- A The structures increase the rate of absorption of digested food.
- B The structures provide a greater surface area for the absorption of water.
- C The structures provide a greater surface area for the absorption of the digested food into the bloodstream.

- (1) A only
- (2) B only
- (3) A and B only
- (4) A and C only

(Go on to the next page)

- 8 The diagram below shows a seedling.



Which one of the following graphs below is correct?

(1)

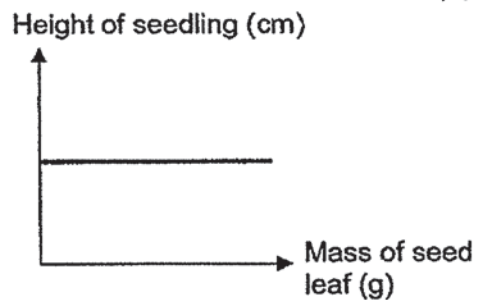

(2)

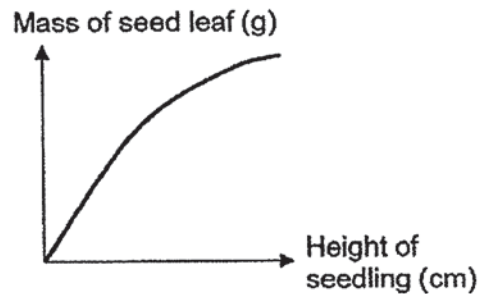

(3)

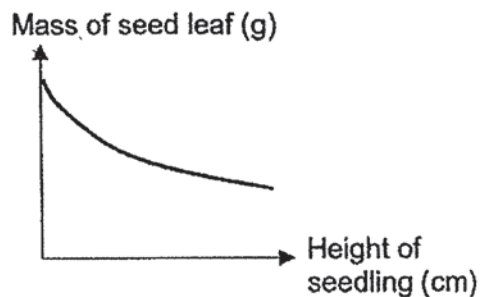

(4)

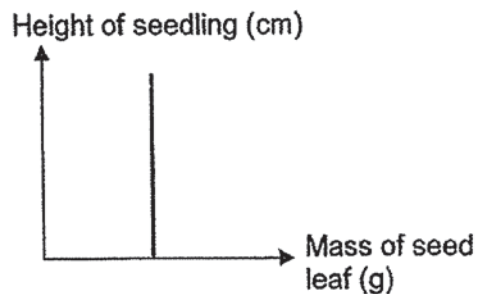

- 9 The table below shows some characteristics of organisms A and B.

Characteristics	Organism A	Organism B
Lays eggs	Yes	Yes
Its young resembles its parent	No	No
Number of stages in its life cycle	Four	Three

Which of the following best represent organisms A and B?

	Organism A	Organism B
(1)	butterfly	penguin
(2)	dragonfly	cockroach
(3)	cockroach	frog
(4)	mosquito	toad

(Go on to the next page)

10

The diagrams below show the dispersal patterns for three different types of plants, X, Y and Z.

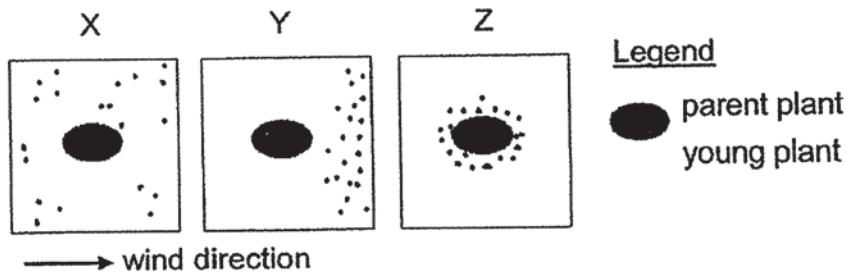

Which of the following are likely characteristics of the fruits of the plants?

	Plant X	Plant Y	Plant Z
(1)	wing-like structure	fibrous husk	dries up when ripe
(2)	stiff hairs	wing-like structure	splits open when ripe
(3)	feathery and light	fibrous husk	fleshy and juicy
(4)	fleshy and juicy	splits open when ripe	feathery and light

11

The diagram below shows a baby developing in a mother's womb.

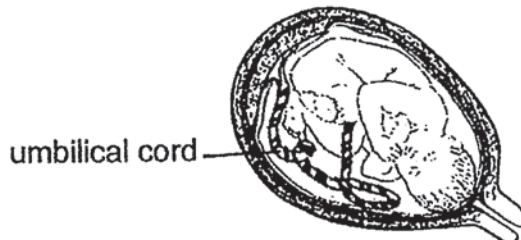

Which of the following statements about the umbilical cord are correct?

- A Fertilisation takes place in the umbilical cord.
- B It connects the developing baby to the mother.
- C It carries food and oxygen from the mother to the developing baby.
- D Wastes from the developing baby are passed out through the umbilical cord.

- (1) A and B only
- (2) B and C only
- (3) C and D only
- (4) B, C and D only

(Go on to the next page)

- 12 The table below shows some physical features of Mr Raju and his wife, Mrs Raju.

Parent	Face	Earlobes	Hair	Eyelid
Mr Raju	no dimple	attached	short	double
Mrs Raju	dimple	detached	long	single

Mr Raju and Mrs Raju have four children with the following physical features.

Child	Face	Earlobes	Hair	Eyelid
Aru	dimple	detached	short	double
Bala	no dimple	attached	long	double
Chitra	no dimple	detached	short	single
Devi	dimple	attached	long	single

Based on the information above which of the following statements are true?

- A Aru and Chitra are twins.
- B Chitra is the only child who inherited Mr Raju's physical features.
- C Bala did not inherit any physical features from his mother.
- D Aru and Devi each inherited two physical features from their mother.

- (1) A and D only
- (2) B ^{and} C only
- (3) C and D only
- (4) A, B and C only

(Go on to the next page)

- 13 Two cells, X and Y, were taken from the different parts of plant M as shown below.

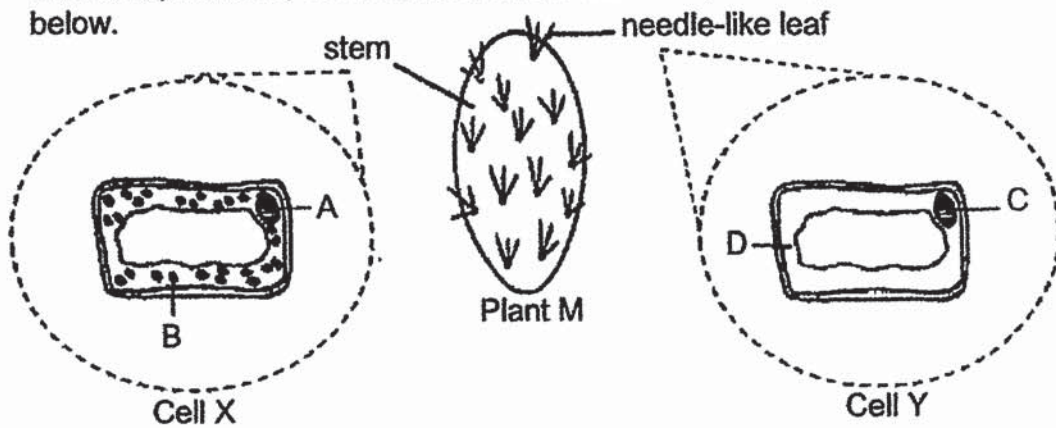

Which of the following is correct?

	Part of plant M that is able to make food	Part of the cell that contains the green pigment
(1)	stem	A
(2)	leaf	C
(3)	stem	B
(4)	leaf	D

- 14 Sara put a plant into a beaker of water in which some red ink had been added. A few hours later, she observed that the flower petals had turned from white to red.



What could Sara conclude from her experiment?

- (1) The stem holds the plant upright.
- (2) Water is taken in by the plant through its roots.
- (3) The plant needs water to make food and to grow.
- (4) The stem transports water to the other parts of the plant.

(Go on to the next page)

- 15 The picture below shows a piece of paper passing through a paper shredder.

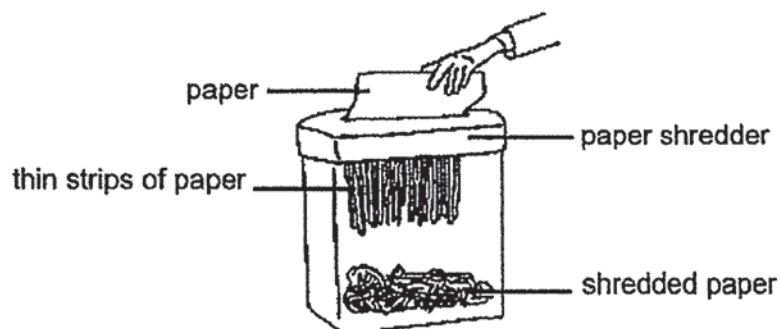

Which organ of the human digestive system carries out the same function as the paper shredder?

- (1) Teeth
 - (2) Gullet
 - (3) Tongue
 - (4) Small intestines
- 16 Daryl moved a magnet towards a toy lorry, as shown below and observed that the lorry did not move.

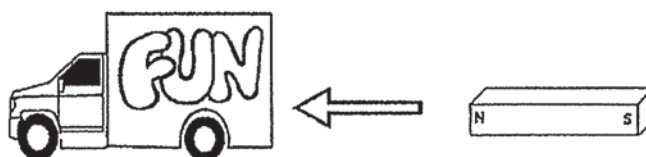

What material could the toy lorry be made of?

- A iron
 - B steel
 - C copper
 - D aluminium
- (1) C only
 - (2) A and B only
 - (3) C and D only
 - (4) B, C and D only

(Go on to the next page)

17 The table below shows some characteristics of four materials.

Characteristic	Material A	Material B	Material C	Material D
Waterproof	yes	no	yes	yes
Flexible	yes	yes	no	no
Transparent	no	yes	yes	no

Which material is the most suitable for making part X of a greenhouse as shown below?

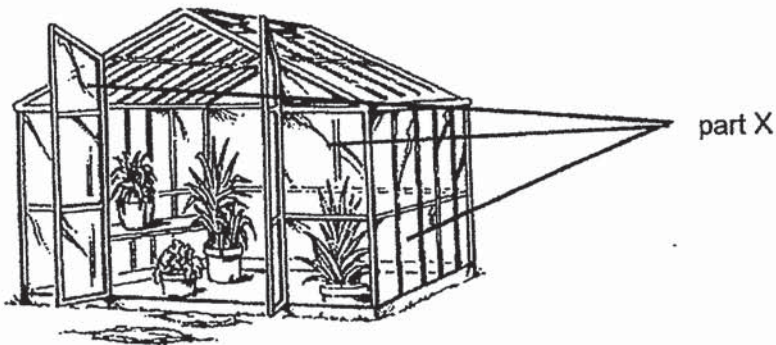

- (1) Material A
- (2) Material B
- (3) Material C
- (4) Material D

18 Which of the following are examples of matter?

	Matter			
(1)	oxygen	shadow	mist	snow
(2)	snow	water	light	water vapour
(3)	ice	air	heat	water
(4)	mist	water	ice	water vapour

(Go on to the next page)

- 19 Minah and her brother were playing table tennis when she accidentally stepped on the ping pong ball and made a dent as shown below.



Which one of the following observations is correct after Minah stepped on the ping pong ball and made a dent in the ball?

	Volume of air in ping pong ball	Mass of the ping pong ball
(1)	remains the same	remains the same
(2)	decreases	decreases
(3)	decreases	remains the same
(4)	remains the same	decreases

- 20 The graph below shows how the temperature of water in a beaker changes when heated over time.

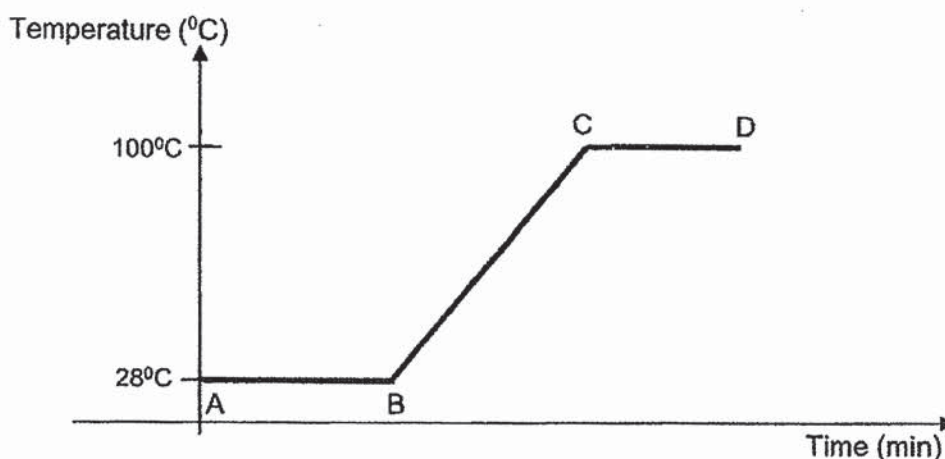

Which line in the graph shows the boiling point of the water?

- (1) AB
- (2) BC
- (3) CD
- (4) BD

(Go on to the next page)

- 21 Two identical cups, A and B were each filled with the same amount of water. The temperature of water in cup A and B were 40°C and 5°C , respectively. They were left in the science room for forty minutes.

Which one of the graphs correctly shows the change of temperature for the two cups of water?

(1)

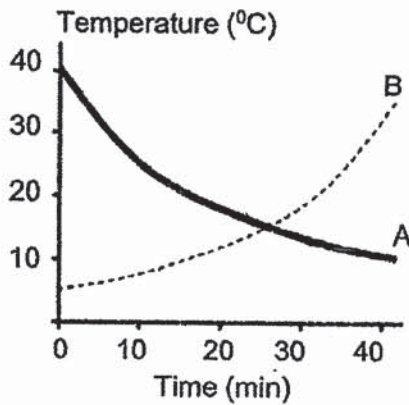

(2)

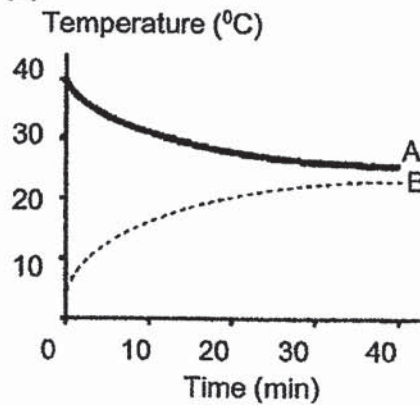

(3)

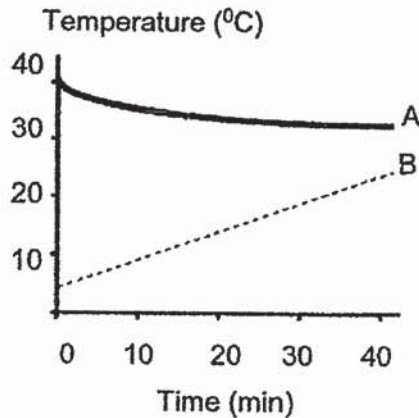

(4)

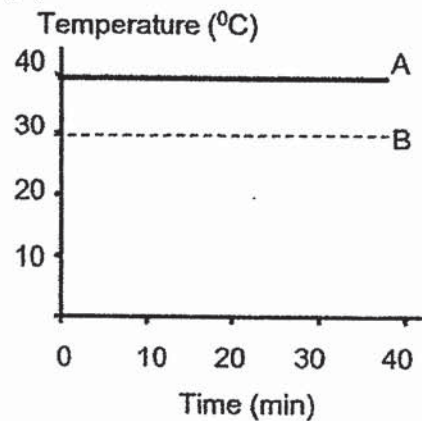

(Go on to the next page)

- 22 An experiment was conducted to investigate if light could pass through four different materials, W, X, Y and Z. The materials were of equal size and arranged in two set-ups, P and Q, as shown below.

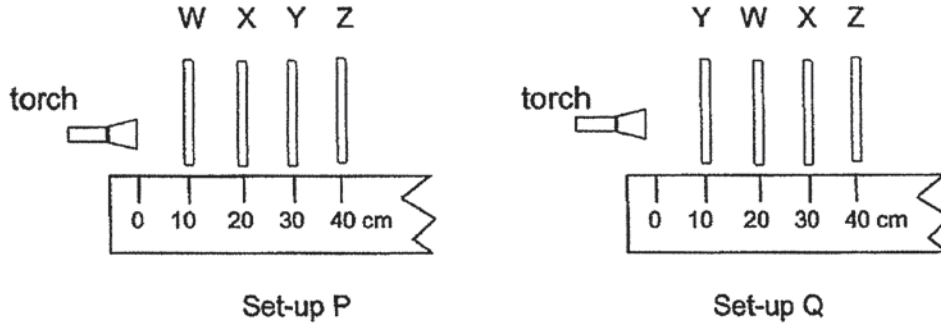

The distance travelled by light in each set-up was measured and recorded in the table as shown below.

	Set-up P	Set-up Q
Distance travelled by light (cm)	20	30

Which of the following correctly describe the degree of transparency for materials W, X, Y and Z?

Does it allow light to pass through?				
	W	X	Y	Z
(1)	No	not sure	yes	no
(2)	Yes	no	yes	not sure
(3)	not sure	yes	no	yes
(4)	Yes	no	not sure	no

(Go on to the next page)

23 Mary could see her black cat in a dimly lit room.

Which diagram shows why Mary could see the cat's eyes clearly?

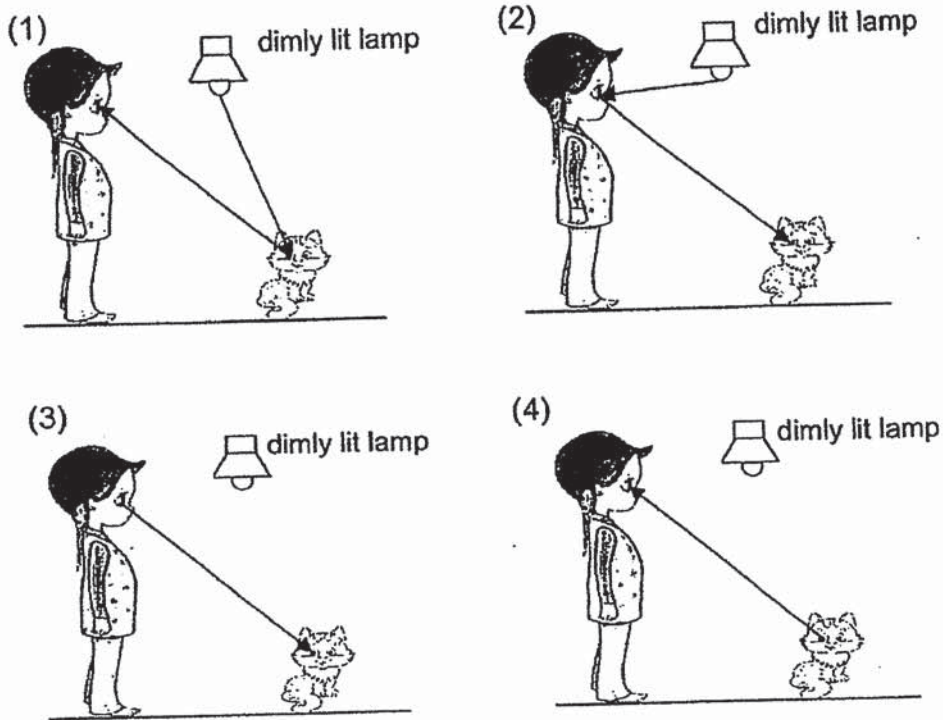

24 The diagram below shows a beaker filled with 500 ml of boiling water. The beaker is then covered completely with a metal lid with blue-coloured ice cubes placed on it.

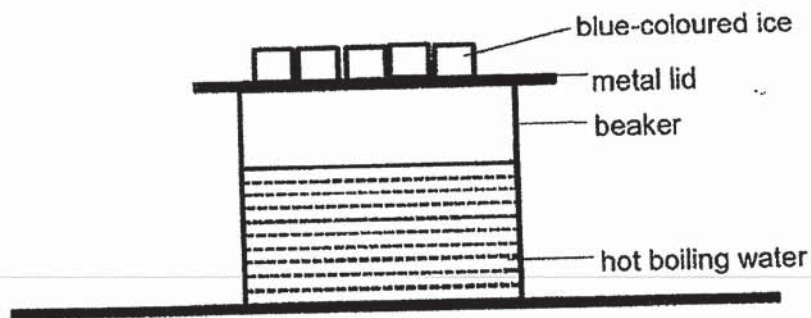

After one hour, water droplets were formed.

Which of the following correctly states the colour of the water droplets and where the water droplets were formed?

	Colour of water droplets	Place where water droplets were formed
(1)	Blue	under the metal lid
(2)	Clear	outside the beaker
(3)	Clear	under the metal lid
(4)	Blue	inside and outside the beaker

(Go on to the next page)

- 25 Meiling carried out an experiment to find out how the exposed surface area affects the rate of evaporation. She used four identical T-shirts, A, B, C and D. She soaked each T-shirt with an equal amount of water and placed them on a table for six hours as shown below.

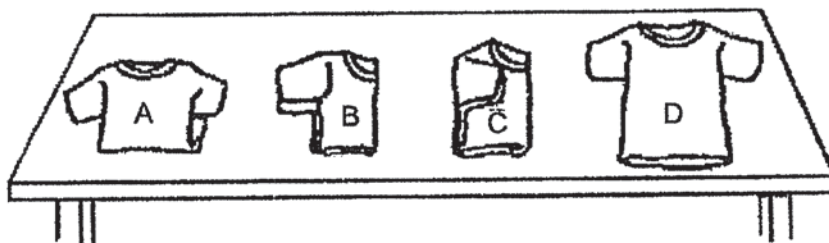

Meiling recorded the mass of each T-shirt after the experiment.

T-shirt	Mass of T-shirt at the start of the experiment (g)	Mass of T-shirt at the end of the experiment (g)
A	30	10
B	30	14
C	30	20
D	30	5

Which one of the following statements explains Meiling's results as shown above?

- (1) The bigger the size of the T-shirt, the more water is evaporated.
- (2) The lighter the mass of the T-shirt, the less water is evaporated.
- (3) The thicker the material of the T-shirt, the less water is evaporated.
- (4) The bigger the exposed surface area of the T-shirt, the more water is evaporated.

(Go on to the next page)

- 26 The diagram shows how processes A, B and C caused the state of water to change.

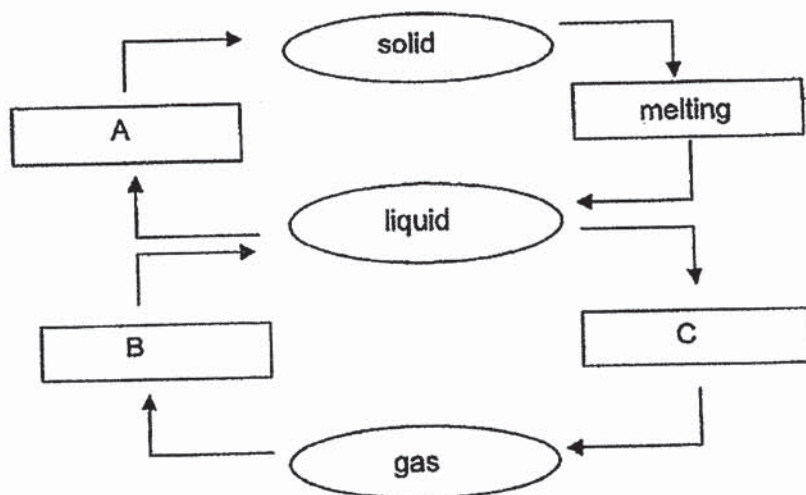

Which of the following correctly describe processes A, B and C?

	A	B	C
(1)	freezing	condensation	evaporation
(2)	freezing	evaporation	condensation
(3)	melting	freezing	evaporation
(4)	melting	condensation	freezing

- 27 Three substances, A, B and C are heated to 80°C. The table below shows the states at which the substances A, B and C are at 80°C.

Substances	State at which substances are at 80°C
A	solid
B	gas
C	liquid

Based on the information above, which of the following correctly show the melting and boiling point of substances A, B and C?

Substance	Melting point (°C)	Boiling point (°C)
A	110	280
B	44	100
C	20	90

- (1) A only
 (2) B and C only
 (3) A and C only
 (4) A, B and C

(Go on to the next page)

- 28 The graph below shows the usage of water for the Tan family from April to July.

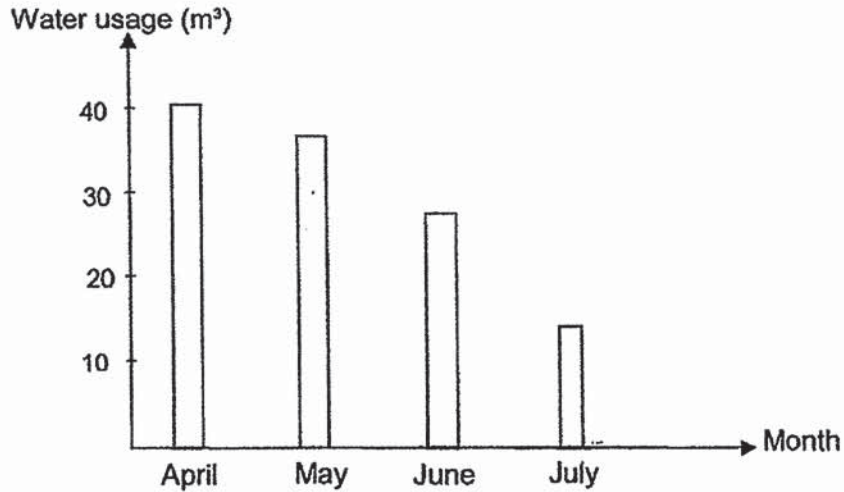

Which of the following activities are the reasons for the change in the usage of water for the Tan family?

- A Taking shorter showers daily
- B Washing half load of laundry in a machine
- C Washing the family car with a running water hose
- D Rinsing with a cup and not under a running tap after meals

- (1) A and B only
- (2) A and D only
- (3) A and C only
- (4) A, B and D only

METHODIST GIRLS' SCHOOL
Founded in 1887



MID-YEAR EXAMINATION 2019
PRIMARY 5
SCIENCE

BOOKLET B1

Total Time for Booklets A and B: 1 hour 45 minutes

INSTRUCTIONS TO CANDIDATES

Do not turn over this page until you are told to do so.
Follow all instructions carefully.
Answer all questions.

Name: _____ ()

Class: Primary 5. _____

Date : 14 May 2019

Booklet A	56
Booklet B1	22
Booklet B2	22
Total	100
Parent's Signature	

This booklet consists of 10 printed pages including this page.

For questions 29 to 34, write your answers in the spaces provided. The number of marks available is shown in brackets [] at the end of each question or part question.

[22 marks]

- 29 Jim wanted to find out the effect of different temperatures on the number of days needed for each stage of the life cycle of organism X. He observed and recorded his findings in the table below.

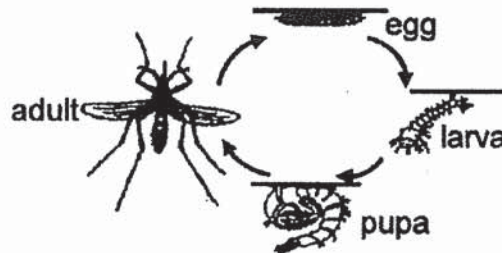

Stage	Number of days needed for each stage at different temperatures			
	27°C	29°C	31°C	33°C
Egg	3	3	3	3
Larva	10	9	8	7
Pupa	3	3	3	3

- (a) Which group of animals does organism X belong to? Give a reason for your answer. [1]

- (b) From the results above, how would temperature affect the length of one complete life cycle of organism X? [1]

- (c) Why does organism X lay many eggs at one time? [1]

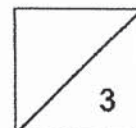

(Go on to the next page)

- 30 Siti had a plate of chicken rice for dinner. The graph below shows how the amount of undigested food changed as the food passed through the different parts of her digestive system.

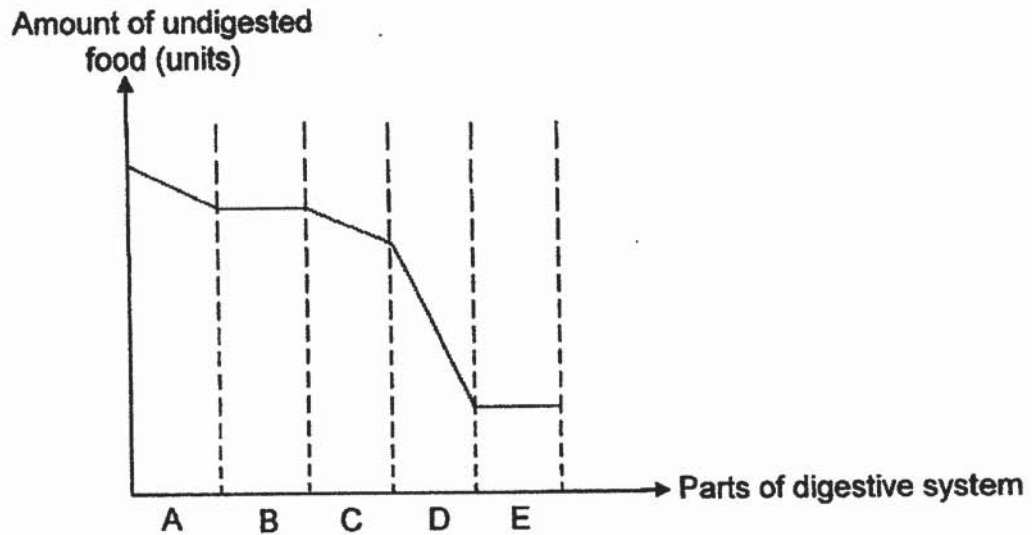

- (a) What happens to the food when it is at part A? [1]

- (b) In which part of Siti's digestive system, A, B, C, D or E, was the food completely digested? Give a reason for your answer. [1]

- (c) Name the organ that represents part E and state its function. [1]

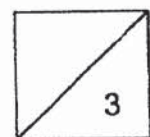

(Go on to the next page)

- 31 The diagrams below show the reproductive systems of a plant and a human.

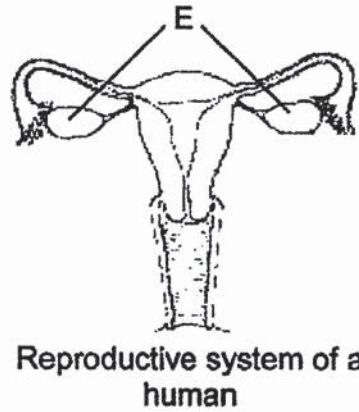
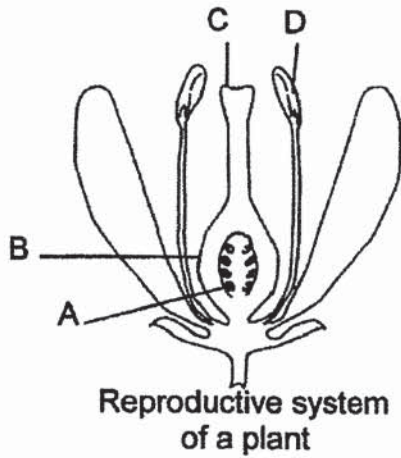

- (a) Which part, A, B, C or D, of the reproductive system of the plant has the same function as part E of the human reproductive system? Give a reason for your answer. [1]

The diagram below shows some cells during a process that took place in the reproduction of a human.

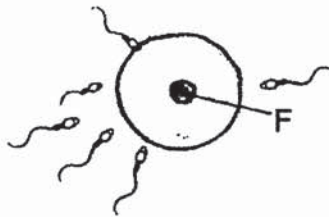

- (b) Other than controlling all the activities of the cell, state another function of part F. [1]

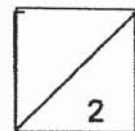

(Go on to the next page)

The flower of plant Q goes through two processes, W and X, before it becomes a fruit as shown below.

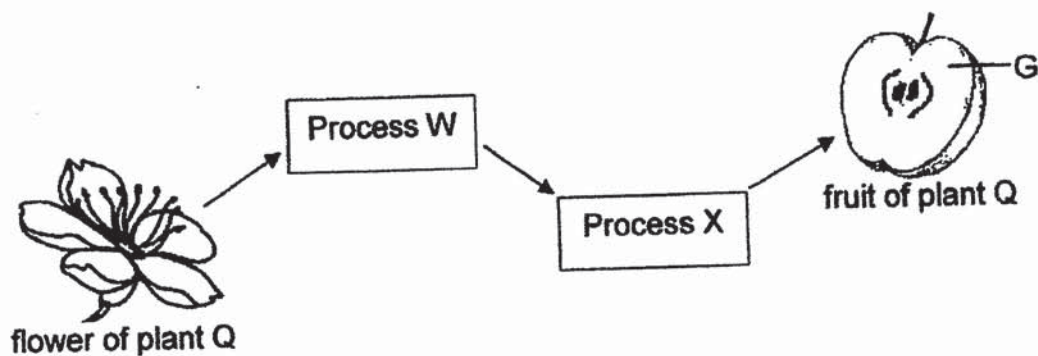

(c) Why is process W important? [1]

(d) Describe how part G developed from the flower. [1]

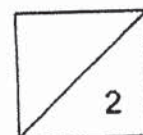

(Go on to the next page)

32 The diagram below shows the fruit of a plant.

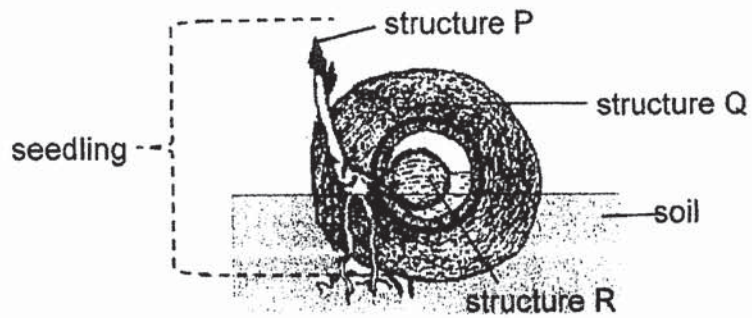

Structure P develops through a certain process.

- (a) Identify the process and state all the conditions needed for this process to take place. [2]

Structure R serves an important function before structure P develops fully.

- (b) Explain the importance of structure R. [1]

The plants are commonly found growing along the river.



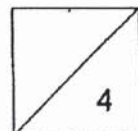

- (c) State the characteristic of structure Q and explain how it helps the fruit in its dispersal. [1]

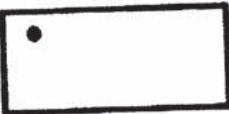
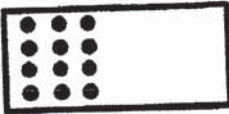

(Go on to the next page)

- 33 Bacteria X could be found on raw food and could cause a person to fall sick when it is present in large amount.

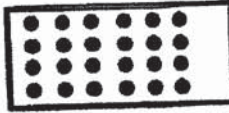
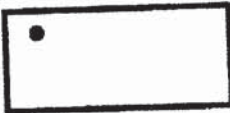
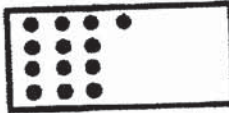
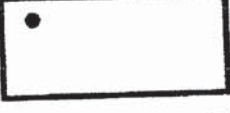
Siti conducted an experiment to find out how quickly bacteria X could reproduce when it was kept at different temperatures. She observed the bacteria under a microscope at the start of the experiment and after 30 minutes. The table below shows her results.

Temperature at which bacteria X is kept (°C)	Amount of bacteria X (unit)	
	Start of experiment	End of experiment (after 30 mins)
30°C		
36°C		
41°C		
46°C		

- (a) Based on the results above, describe how the changes in temperature affected the amount of bacteria X. [1]

- (b) A human body temperature is about 37°C. Based on the results above, explain clearly how eating uncooked salmon, containing bacteria X could cause a person to fall sick? [1]

The diagram below shows a solar-powered vehicle which had won in the World Solar Challenge Race below.

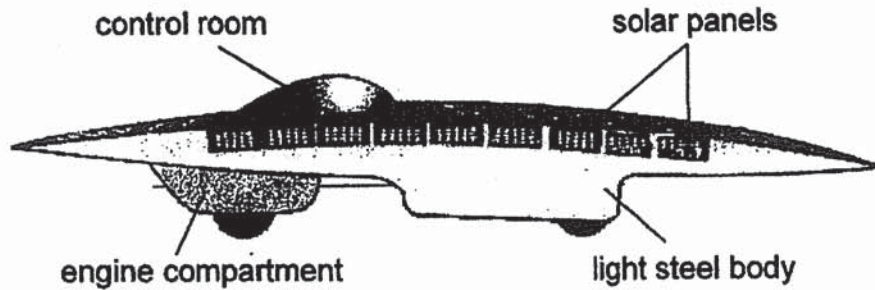

- (c) If the vehicle above was to model a plant cell, which part of the plant cell would be best represented by the light steel body? Give a reason for your answer. [1]

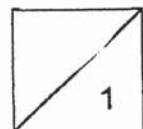

(Go on to the next page)

34 The diagram below shows four parts of a flowering plant.

(a) **Draw** arrows (→) in the diagram below to show how water is transported in a plant. [1]

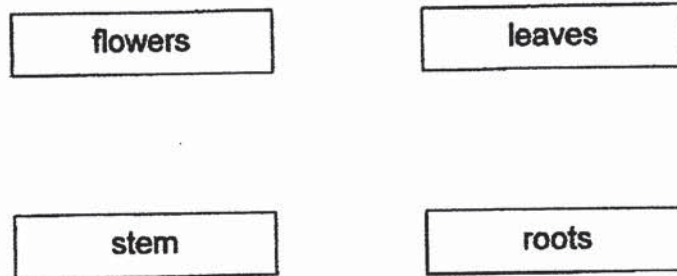

The diagram below shows an insect eating its way into the stem of a plant.

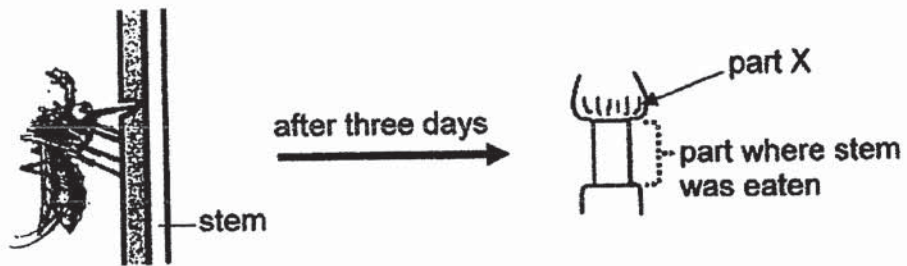

After three days, it was observed that part X of the stem was swollen.

(b) Explain how this would eventually affect the growth of the roots. [1]

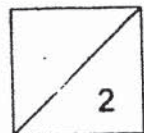

(Go on to the next page)

An experiment was conducted to find out if different ways of cutting the stalks of roses would affect the amount of water taken in by them. Two similar vases, A and B, were filled with some water. A stalk of white rose was then placed into each vase. Both vases were placed at the same location. Each stalk of rose was cut in two different ways, X and Y, as shown below.

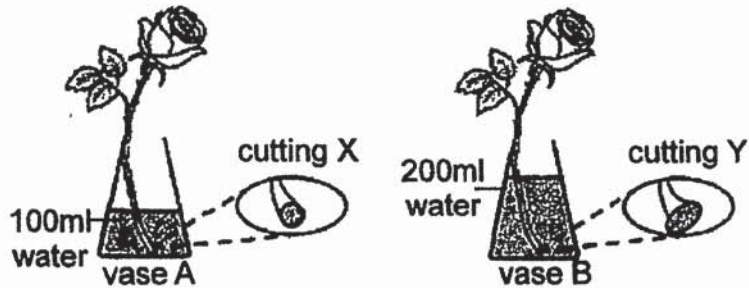

- (c) What could be measured to determine which stalk of rose had taken in more water? [1]

- (d) Based on the set-ups as shown above, explain why the experiment was not fair. [1]

Some changes were made to the set-up as shown in the diagram below.

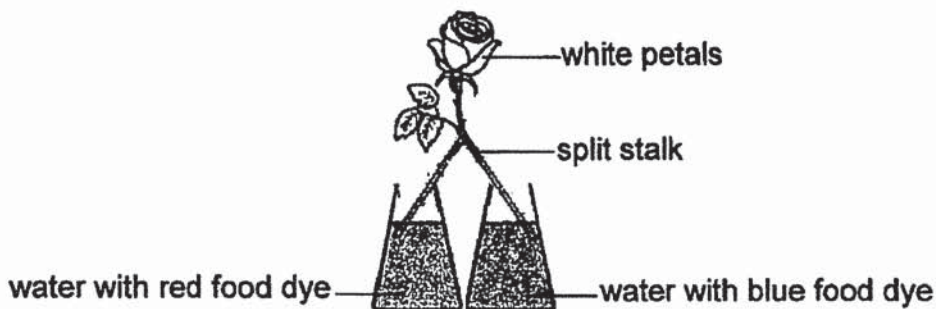

- (e) What would happen to the white petals when the set-up was left overnight? Give a reason for your answer. [1]

METHODIST GIRLS' SCHOOL

Founded in 1887



**MID-YEAR EXAMINATION 2019
PRIMARY 5
SCIENCE**

BOOKLET B2

Total Time for Booklets A and B: 1 hour 45 minutes

INSTRUCTIONS TO CANDIDATES

Do not turn over this page until you are told to do so.
Follow all instructions carefully.
Answer all questions.

Name: _____ ()

Class: Primary 5.

Date : 14 May 2019

Booklet B2	22
------------	----

This booklet consists of 10 printed pages including this page.

For questions 35 to 42, write your answers in the spaces provided. The number of marks available is shown in brackets [] at the end of each question or part question.

[22 marks]

- 35 Mary set up an experiment as shown below to compare a property among three strips made of different materials, A, B and C.

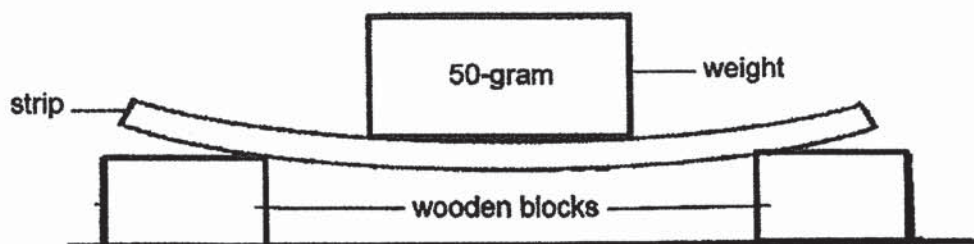

She added 50-gram weights onto each strip and measured the amount of weights each strip could hold until it broke.

Material	Mass that the material could hold until it broke (g)
A	50
B	100
C	200

- (a) Based on the results above, which material, A, B or C, is the most suitable for making a food tray? Explain your answer. [1]

Mary found that material B could be used to make part X of an umbrella.



- (b) What are two important properties of material B which will protect Mary from the unpredictable weather? [1]

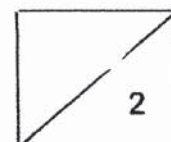

(Go on to the next page)

- 36 In factory P, steam was produced and allowed to flow through metal pipes from one place to another. When straight pipes were used, the pipes will be damaged as shown below.

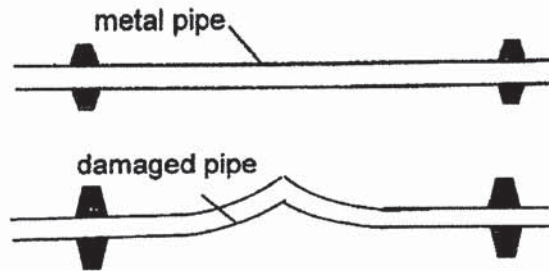

To prevent pipes from being damaged, pipes are fixed with a bend as shown below.

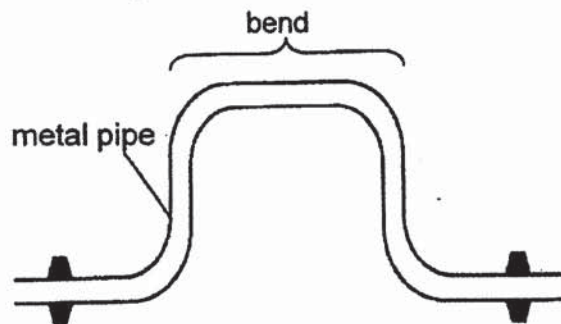

- (a) How does the bend prevent the pipe from being damaged? [1]

After some time, factory P replaced the metal pipes with new pipes made of material L. It was observed that the new pipes were not damaged like the old pipes when steam flowed through.

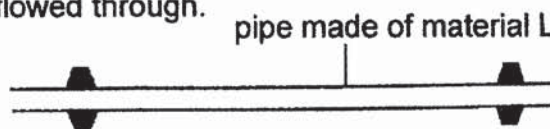

- (b) Give a reason why the new pipes were not damaged when steam flowed through, unlike the old pipes. [2]

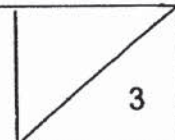

(Go on to the next page)

- 37 Ali tied a bar magnet to a rubber band and hung it above an electromagnet as shown below. Distance x measured the distance between the electromagnet and the bar magnet. When the wire was not connected to the battery, distance x was 3 cm.

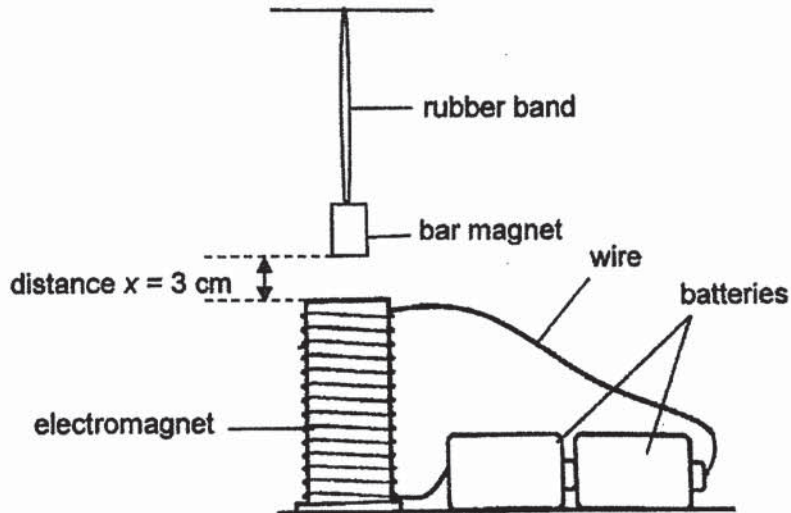

When Ali connected the wire to the battery, distance x increased to 3.5 cm.

- (a) Why did distance x increase when the wire was connected to the batteries? [1]

Ali then added one more battery to the set-up.

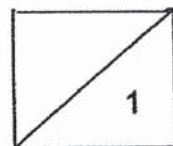
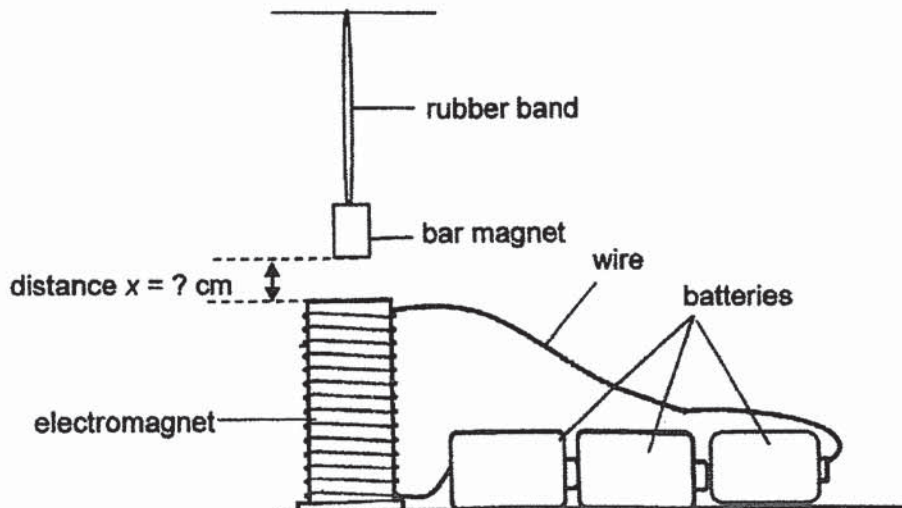

(Go on to the next page)

- (b) What would be the new distance between the electromagnet and the bar magnet after the wire was connected to the batteries?
Put a tick in the correct box.

4 cm 3.5 cm 3 cm

Give a reason for your answer.

[1]

Ali then replaced the bar magnet with object Z. He observed that distance x decreased to 2 cm when the wire was attached to the battery.

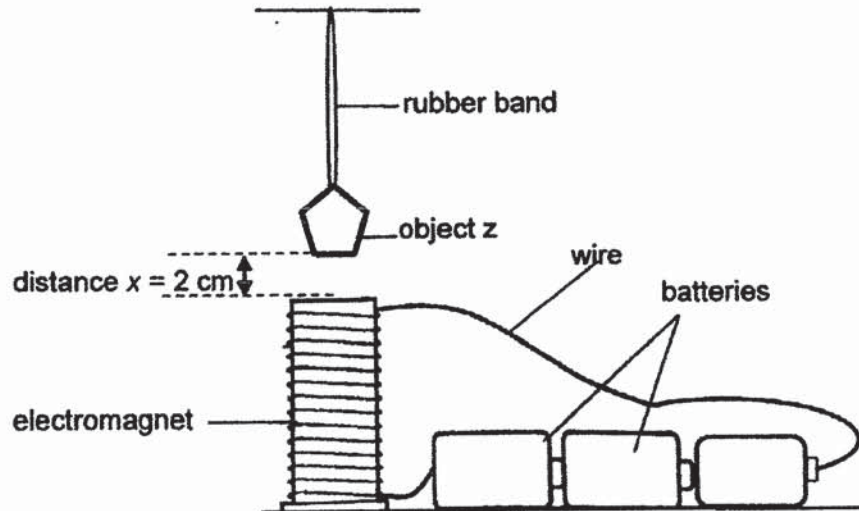

- (c) Suggest a possible reason for Ali's observation.

[1]

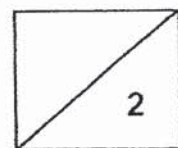

(Go on to the next page)

- 38 Sumei carried out an experiment by pouring an equal amount of liquids, X and Y, at 80°C into two similar flasks and lowered them into a basin of cold water for five minutes.

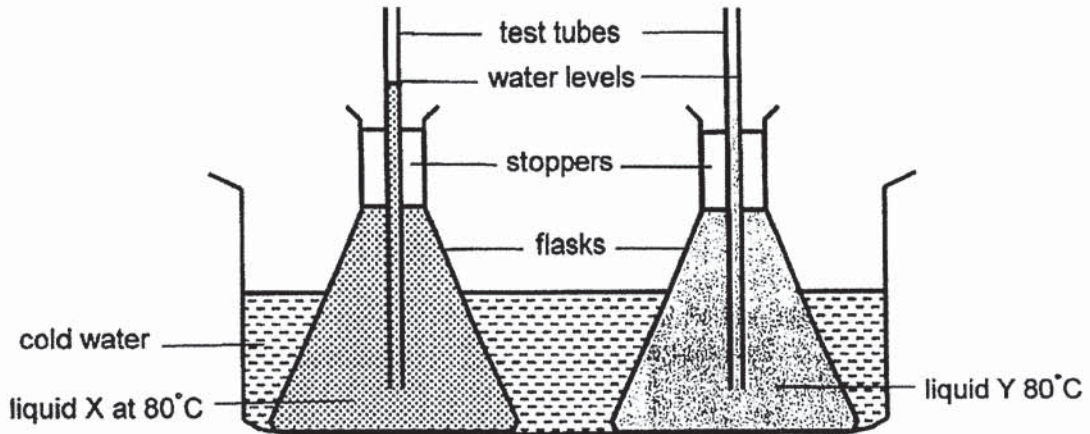

She then plotted a graph below to show how the temperatures of liquid X and Y changed over time.

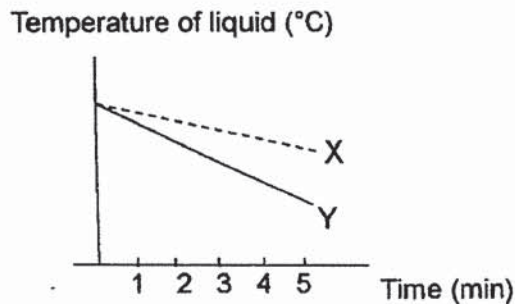

- (a) Which liquid, X or Y, would Sumei observe a lower level in the test tube after five minutes? Explain your answer based on the graph above. [2]

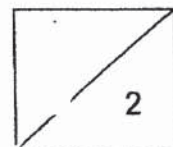

(Go on to the next page)

Sumei then poured an equal amount of liquid X at 26°C into three similar beakers. She put each beaker into three similar boxes, A, B and C, with a different temperature in it for five hours.

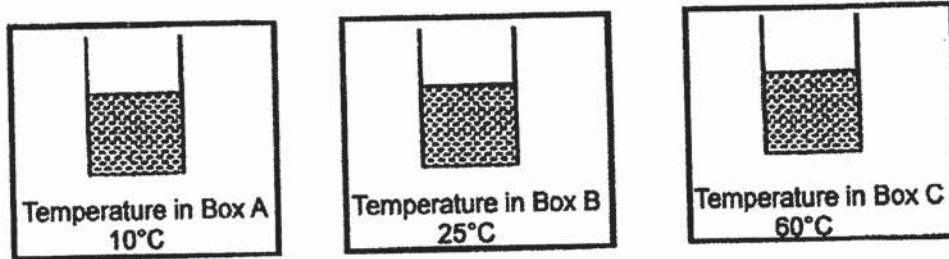

(b) The graph below shows the amount of liquid X left in each beaker after five hours.

Write the correct letters, A and C, in the appropriate boxes below to indicate the graph for the amount of liquid X left in the beakers of boxes A and C after five hours. [1]

Amount of liquid X (ml)

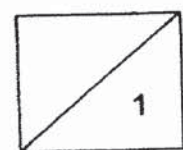
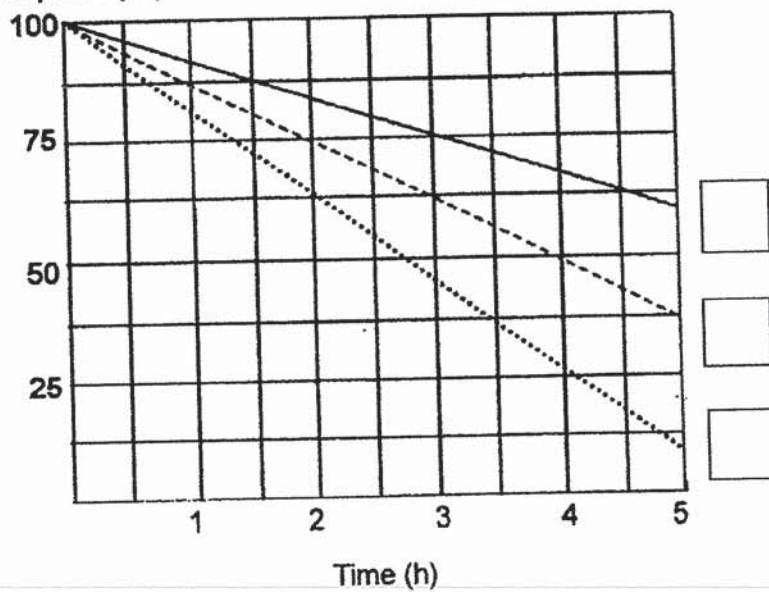

(Go on to the next page)

(c) Describe clearly how the following variables when kept the same would help Sumei's experiment to be a fair one. [2]

(i) Using similar beakers:

(ii) Putting the same amount of liquid:

39 Farah put two packets of hot french fries into Box R and S as shown below.

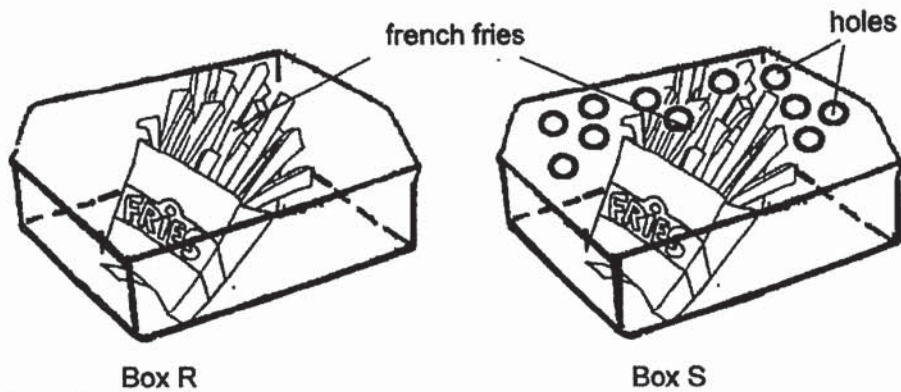

she observed
~~she observed~~ that the french fries in one of the boxes were crispy while the french fries in the other box turned slightly moist after some time.

Which box, R or S, has french fries that remained crispy? Explain your answer. [2]

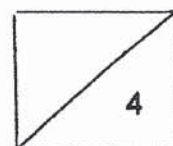

(Go on to the next page)

- 40 The shadows of four artistes, A, B, C and D, who were of similar heights, are cast on a screen as shown in the diagram below.



The positions of the four artistes between the light source and the screen are as shown below.

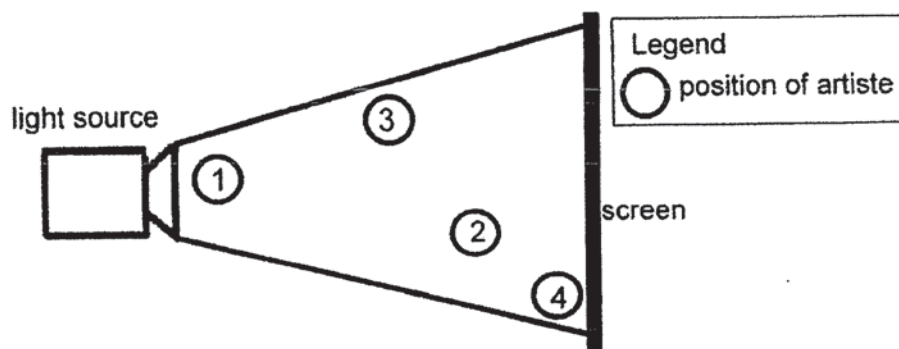

- (a) How are the shadows formed? [1]

- (b) At which position, 1, 2, 3 or 4, was artiste C standing? Explain your answer. [2]

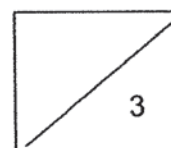

(Go on to the next page)

- 41 Mr Tan parked his car at an open car park at night. The next morning, he noticed substance X on his car windscreen. There was no rain the night before.



- (a) What is substance X? [1]

Substance X was formed through a process in the diagram as shown below.

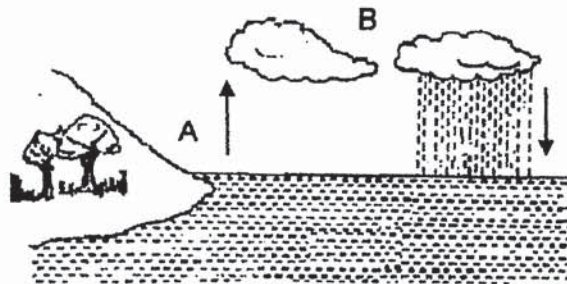

- (b) Which process, A or B, resulted in the formation of substance X? Explain how substance X was formed. [2]

Mr Tan then decided to park his car at a sheltered car park. The next morning, he noticed that less substance X was formed on his car windscreen. [1]

- (c) Give a reason for Mr Tan's observation.
-
-

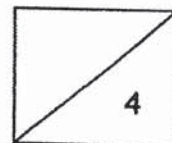

Methodist Girls' School (Primary)
P5 Mid-Year Examination 2019
Booklets B1 & B2

Q.	Acceptable Answers
29 a	Insects, because it has three body parts/ 6 legs / a pair of antennae.
29 b	The higher the temperature, the shorter the length of one complete life cycle of organism X.
29 c	To increase the chance of survival so that the young can develop into the adult stage.
30 a	The food is chewed into smaller pieces and partially digested by the saliva.
30 b	Part D. The amount of undigested food stops decreasing after leaving part D.
30 c	Large intestine. Water is absorbed from the undigested food.
31 a	Part B, because they both contain the egg cells/ female reproductive cells.
31 b	It carries the genes that could be passed on from the parents to their young.
31 c	It ensures that the pollen grain is transferred from the anther to the stigma of the flower.
31 d	The male reproductive cell in the pollen tube fuses with the egg cell during fertilization and the ovary develops into part G.
32 a	Germination. The conditions needed are air, water and warmth.
32 b	Structure R provides food for the seedling before it can make its own food using structure P.
32 c	Structure Q is fibrous/ traps air and enables it to be dispersed by water.
33 a	The amount of bacteria increases when the temperature increases from 30°C to 36°C but started to decrease after 36°C.
33 b	The human body temperature is the best temperature for the largest amount of bacteria to be produced so it could cause a person to fall sick.
33 c	The cell wall, because it supports and gives the plant cell its shape.
34 a	<pre> graph TD stem[stem] --> flowers[flowers] stem --> leaves[leaves] stem --> roots[roots] stem --> stems[stems] </pre>
34 b	The food made by the leaves could not be transported down to the roots so the roots would eventually wither and die.
34 c	The amount of water left in the vase. [1]
34 d	The amount of water in the vases is not the same. [1]

34 e	The white petals will be half-red and half-blue because the water mixed with red and blue food dye was carried in separate water-carrying tubes.
35a	Material C is the strongest as it could hold the greatest amount of weight until it broke so it is most suitable for making a food tray, which is used to carry heavy things.
35 b	Waterproof and allows some/ no light to pass through.
36 a	The bend provided space for the hot metal pipe to expand when it gained heat from the steam that flowed through it.
36 b	Material L is a poor conductor of heat so it expands less than the metal pipes.
37 a	Like poles of the bar magnet and the electromagnet repel.
37 b	4 cm. The electromagnet increases its strength causing the bar magnet to repel more.
37 c	Object Z is a magnetic material and it is attracted by the electromagnet.
38 a	Liquid Y, because its temperature decreases more shows that it is a better heat conductor and it will contract more.
b	A and C – 1 st and 3 rd boxes
c i	To ensure the exposed surface area/ temperature of the liquid is the same.
c ii	To ensure the same amount of heat in the liquid.
39	Box S, because the hot water vapour could escape through the holes so less water vapour condense on the box surface to form water droplets.
40a	Shadows are formed when the path of light is blocked by the artistes.
40b	Position 1. The nearer the person is to the light source, the more light is being blocked and a bigger shadow is formed.
41 a	Substance X is water droplet.
41 b	Process B. Warm water vapour in the surrounding lost heat to the cooler windscreen and condensed to form substance X.
41 c	As the temperature of the sheltered carpark is higher, the windscreen is less cool/ warmer and less water vapour condense on it to form substance X.

1. 3	11. 4	21. 2
2. 1	12. 3	22. 2
3. 1	13. 3	23. 1
4. 4	14. 4	24. 3
5. 2	15. 1	25. 4
6. 3	16. 3	26. 1
7. 4	17. 3	27. 3
8. 3	18. 4	28. 2
9. 4	19. 3	
10. 2	20. 3	

BND.