

SINGAPORE CHINESE GIRLS' SCHOOL (PRIMARY)

FIRST SEMESTRAL ASSESSMENT 2019

NAME: \_\_\_\_\_

DATE: 10 May 2019

CLASS: PRIMARY 5

Parent's Signature:

\_\_\_\_\_

**SCIENCE**  
**BOOKLET A**

28 questions

56 marks

Total time for Booklets A & B: 1 h 45 min

**DO NOT OPEN THIS BOOKLET UNTIL YOU ARE TOLD TO DO SO.**

**FOLLOW ALL INSTRUCTIONS CAREFULLY.**



**Booklet A (56 marks)**

For each question from 1 to 28, four options are given. One of them is the correct answer. Make your choice (1, 2, 3 or 4). **Shade the correct oval (1, 2, 3 or 4) on the Optical Answer Sheet.**

1. The diagram below shows Animal W. It lives in the soil and comes out only when the temperature of the environment is cooler.



Animal W

Which characteristic of living things can be observed from the description above?

- (1) Living things die.
  - (2) Living things reproduce.
  - (3) Living things respond to changes.
  - (4) Living things need air, food and water.
2. Observe the table below carefully.

P	Q	R
Ostrich Sparrow Penguin	Whale Tiger Shark	Ant Bee Grasshopper

In the table above, which one of the following organisms is grouped **incorrectly**?

- (1) Bee
- (2) Penguin
- (3) Tiger
- (4) Shark

3. The table below shows the characteristics of the items D, E, F and G.

Items	Can move	Can absorb water	Can reproduce
D	✓		
E		✓	
F	✓	✓	
G			✓

Which one of the following items is likely to be a living thing?

- (1) D
- (2) E
- (3) F
- (4) G

4. Dennis has 2 different plastic cases A and B for his delicate spectacles as shown below.

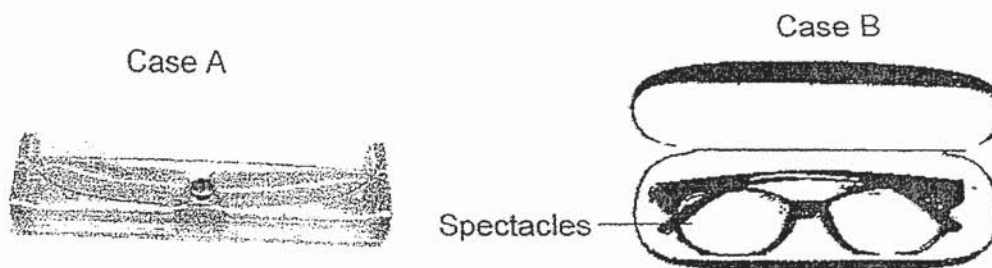

Which of the following shows the reason why his spectacles broke when he placed them in Case A and not Case B?

- (1) Case A is not flexible but Case B is flexible.
- (2) Case A is flexible but Case B is not flexible.
- (3) Case A is transparent but Case B is opaque.
- (4) Case A is waterproof but Case B is not waterproof.

5. 4 pupils made the statements below.

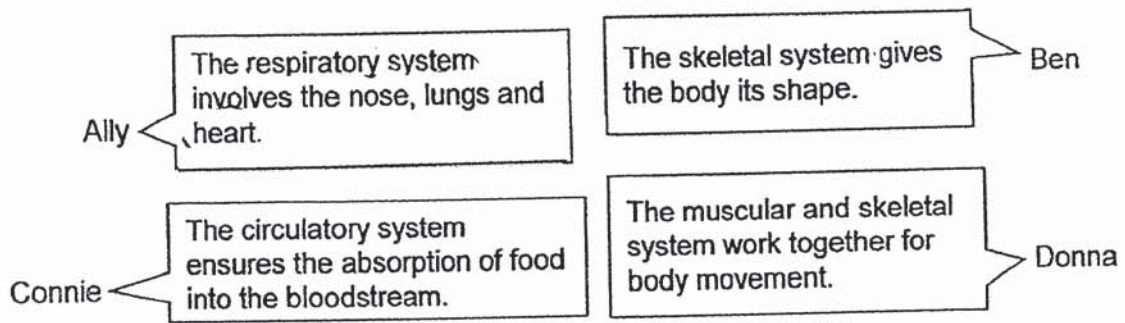

Which of the pupils are correct?

- (1) Ally and Connie only
- (2) Ben and Donna only
- (3) Ally, Ben and Donna only
- (4) All of the pupils

6. Zoe conducted an experiment on the digestive system. She recorded the amount of food digested in different parts of the digestive system in the table below.

Organ	Amount of food digested in the organ (units)
W	50
S	0
T	300

Based on her results, which of the following statements is correct?

- (1) Organ T is the gullet.
- (2) Organ S is the gullet.
- (3) Organ W is the large intestine.
- (4) Organ T is the large intestine.

7. Kiko wrote down some statements on the topic of "Air as a mixture of gases" as shown below.

P: Air contains about 78% of nitrogen.

Q: There is more water vapour than oxygen in the air.

R: There is more oxygen than carbon dioxide in the air.

Which of the following statements about the air around us is/are correct?

- (1) P only  
 (2) Q only  
 (3) P and R only  
 (4) Q and R only

8. Sally caught 2 frogs and placed them in an enclosed container as shown below.

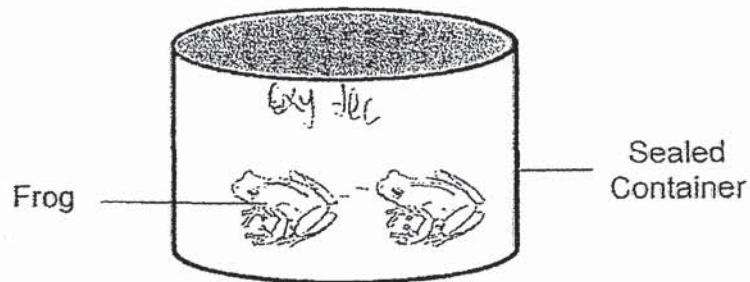

Which of the following shows the possible changes in the amount of oxygen, carbon dioxide and water vapour in the container after a few hours?

	Oxygen	Carbon dioxide	Water vapour
(1)	Increases	Decreases	Increases
(2)	Increases	Decreases	Decreases
(3)	Decreases	Increases	Increases
(4)	Decreases	Increases	Decreases

9. Philip was walking to the bus stop when he saw his bus approaching. He ran as fast as he could to the bus. He caught it and found a seat. The graph below shows Philip's pulse rate over 30 seconds.

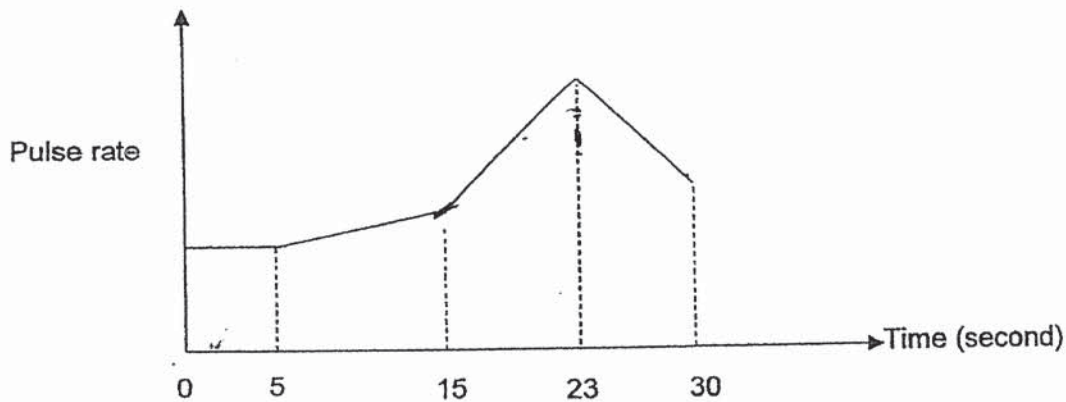

Which of the following statements is correct?

- (1) Philip ran for 8 seconds.
  - (2) Philip ran for 15 seconds.
  - (3) Philip ran for 23 seconds.
  - (4) Philip ~~stopped~~ running at the 15<sup>th</sup> second.  
stopped
10. The diagram below shows the flow of blood in the human body.

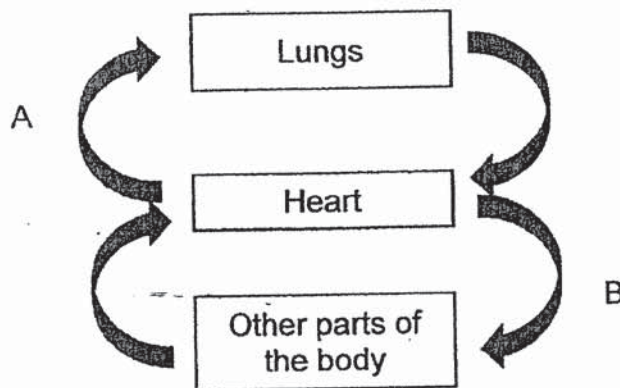

The blood in B has \_\_\_\_\_ than the blood in A.

- (1) less oxygen and less carbon dioxide
- (2) less oxygen and more carbon dioxide
- (3) more oxygen and less carbon dioxide
- (4) more oxygen and more carbon dioxide

11. Which of the following shows where gaseous exchange takes place in a fish and a plant?

	Fish	Plant
(1)	Gills	Stomata
(2)	Gills	Phloem
(3)	Mouth	Stomata
(4)	Mouth	Phloem

12. The diagrams below shows 2 different set-ups.

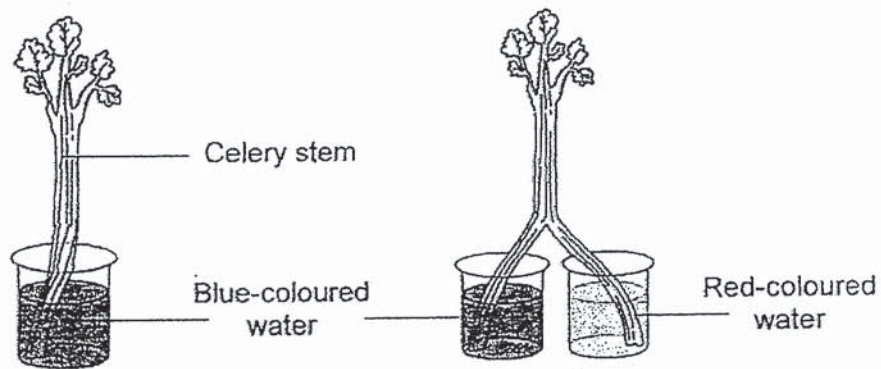

Which of the following shows the possible aim of the experiment?

- (1) To find out if the stem can absorb water.
- (2) To find out if the stem has separate tubes to transport water.
- (3) To find out if the number of stems will affect the amount of water absorbed.
- (4) To find out if the number of leaves will affect the amount of water absorbed.



13. Benedict prepared 3 set-ups as shown below. All of them have an equal volume of water but similar plants with different number of leaves.

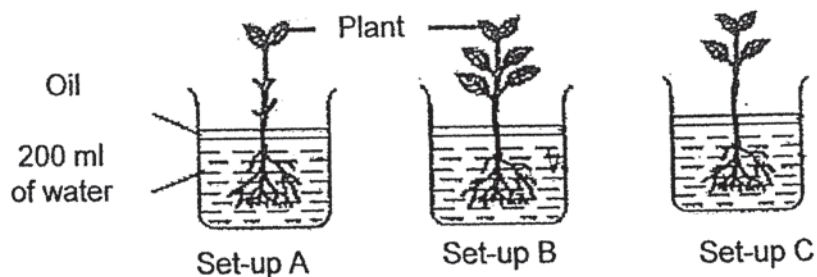

Arrange the set-ups, A, B and C, starting from the set-up with the least water left to the one with the most water left after 3 days.

- (1) A, B, C  
(2) A, C, B

- (3) B, A, C  
(4) B, C, A

14. Mei arranged 4 ring magnets in the position as shown below.

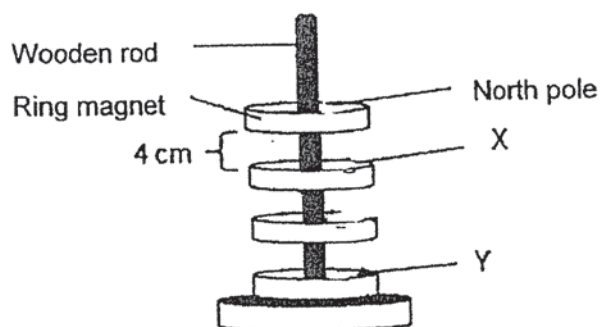

Which of the following correctly identifies X pole and Y pole?

	X pole	Y pole
(1)	North	North
(2)	North	South
(3)	South	North
(4)	South	South

15. Study the classification chart below.

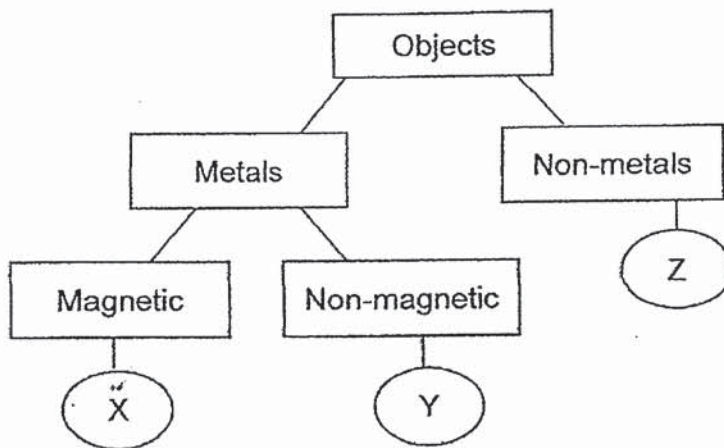

Which of the following represents objects X, Y and Z?

	X	Y	Z
(1)	Iron nail	Gold coin	Plastic cup
(2)	Steel rod	Silver ring	Aluminium foil
(3)	Gold coin	Iron nail	Plastic cup
(4)	Silver ring	Plastic cup	Gold coin

16. The diagram below shows the growth of a seed over a period of time.

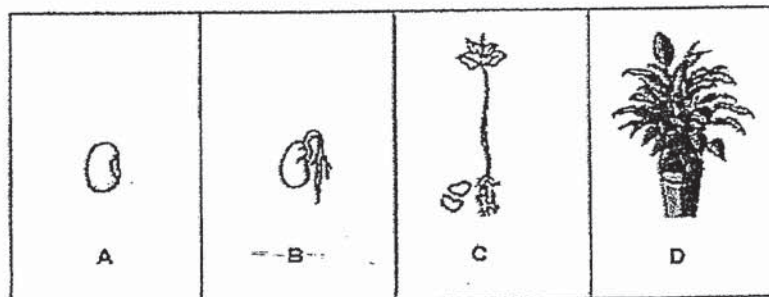

Which of the following is/are needed for plant growth at stage B?

- (1) warmth and water only
- (2) warmth and air only
- (3) water, warmth and air only
- (4) light, water and air only



- 19 Mrs Deanna sets up the experiment as shown below. As she pushes the plunger in, more air is pumped into the container. The container has a capacity of  $100 \text{ cm}^3$ .

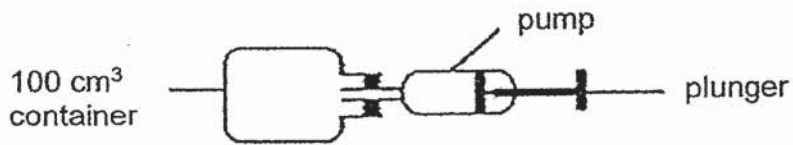

Which of the following graphs show the amount of air in the container as she continues to push the plunger in?

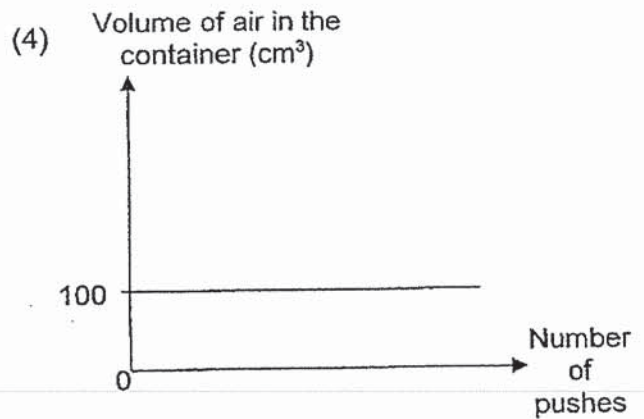
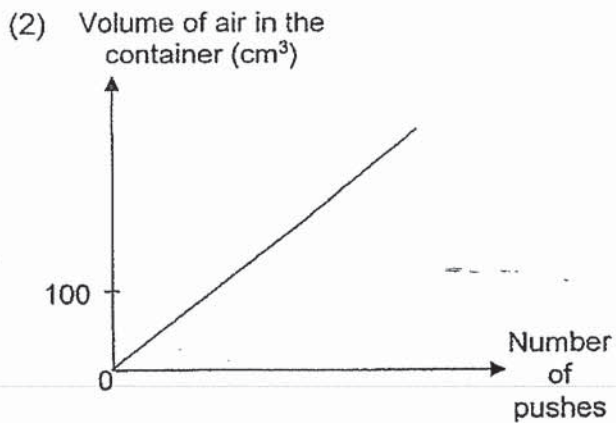
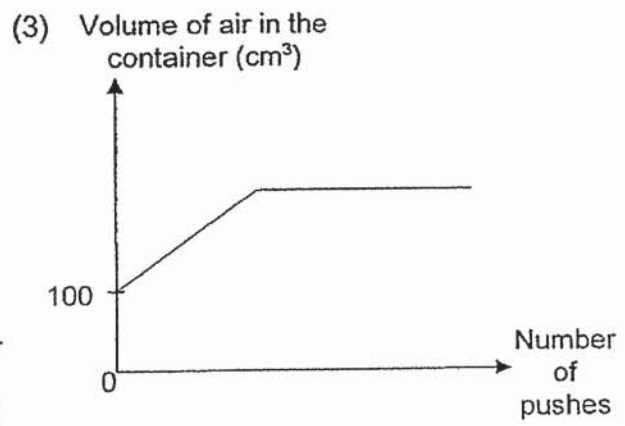
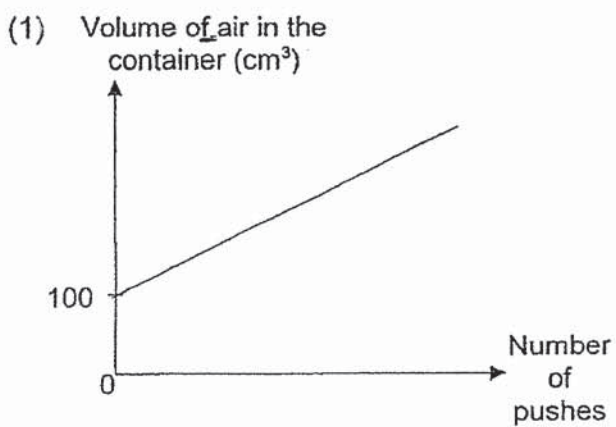

20. The table below shows the melting and boiling points of Substances A, B, C and D.

Substances	Melting point (°C)	Boiling point (°C)
A	10	30
B	20	90
C	120	300
D	45	110

Which of the substances is/are in the solid state at 30°C?

- (1) A only  
 (2) B only  
 (3) A and C only  
 (4) C and D only
21. Ganesh removed a pot of boiling water from the stove and placed it on a table. After that, he took the temperature of the water every 10 minutes.

Which of the following graphs show the temperature of the water correctly?

(1) temperature of water (°C)

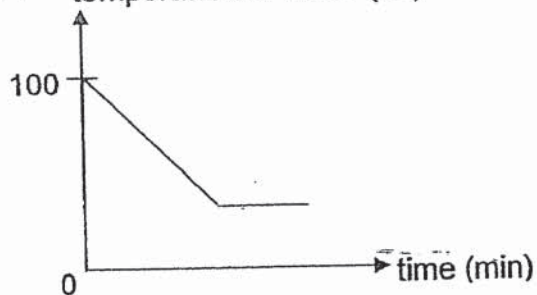

(3) temperature of water (°C)

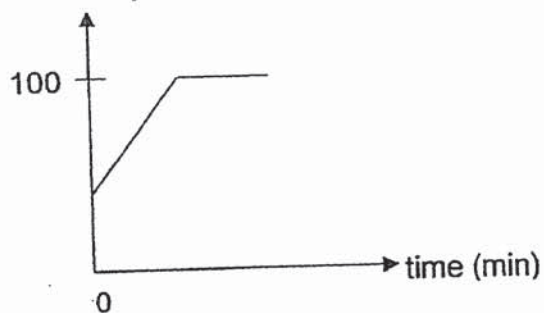

(2) temperature of water (°C)

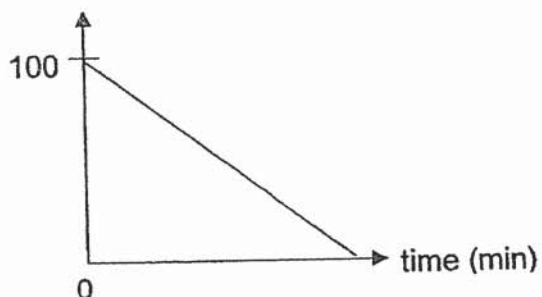

(4) temperature of water (°C)

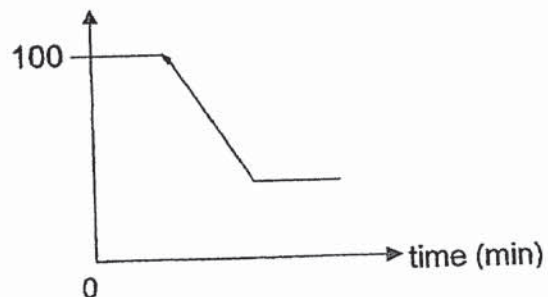

22. Hashim placed an equal volume of water into 4 different containers and placed them near the window. After 3 days, he measured the amount of water left in the containers.

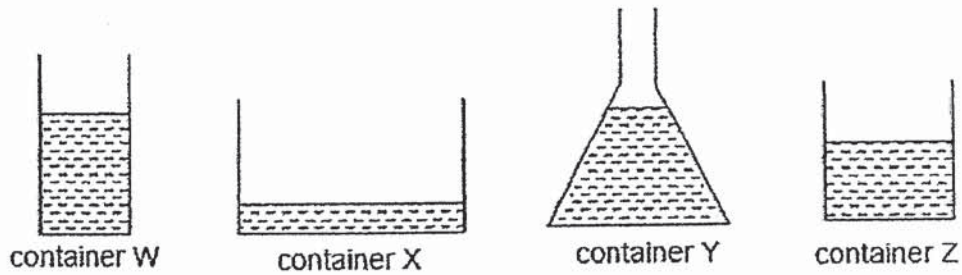

Which of the following containers will have the least amount of water left?

- (1) Container W
- (2) Container X
- (3) Container Y
- (4) Container Z

23. Different amounts of water was poured into 4 similar glasses as shown below. The water are of different temperatures too.

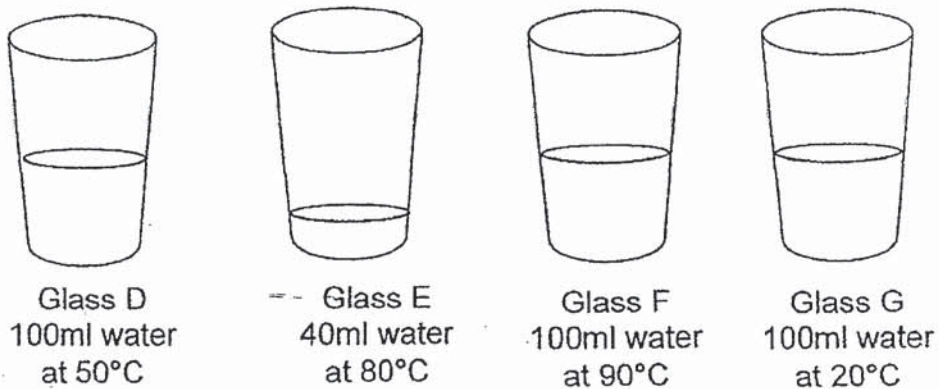

Which one of the glasses has water with the most amount of heat energy?

- (1) Glass D
- (2) Glass E
- (3) Glass F
- (4) Glass G

24. Mr Wong placed a metal spoon into his cup of hot tea.



After a few minutes, the spoon felt hot. Which of the following best explains Mr Wong's observation?

- (1) The metal spoon lost heat to the hot tea.
  - (2) The hot tea lost heat to the metal spoon.
  - (3) The hot tea lost heat to the surrounding air.
  - (4) The metal spoon lost its coolness to the hot tea.
25. Joy could not open the lid of the jam jar and she placed the whole jar into a container of hot water. After a few minutes, she still could not open the lid of the jam jar.



Which of the following best explains why Joy could not open the lid of the jam jar even after placing it in hot water?

- (1) The water was not hot enough.
- (2) Both the lid and jam jar expanded.
- (3) Both the lid and jam jar contracted.
- (4) The jar was not in the hot water long enough.

26. Jolly switches on her lamp whenever she reads. Which of the following arrows shows how light travels?

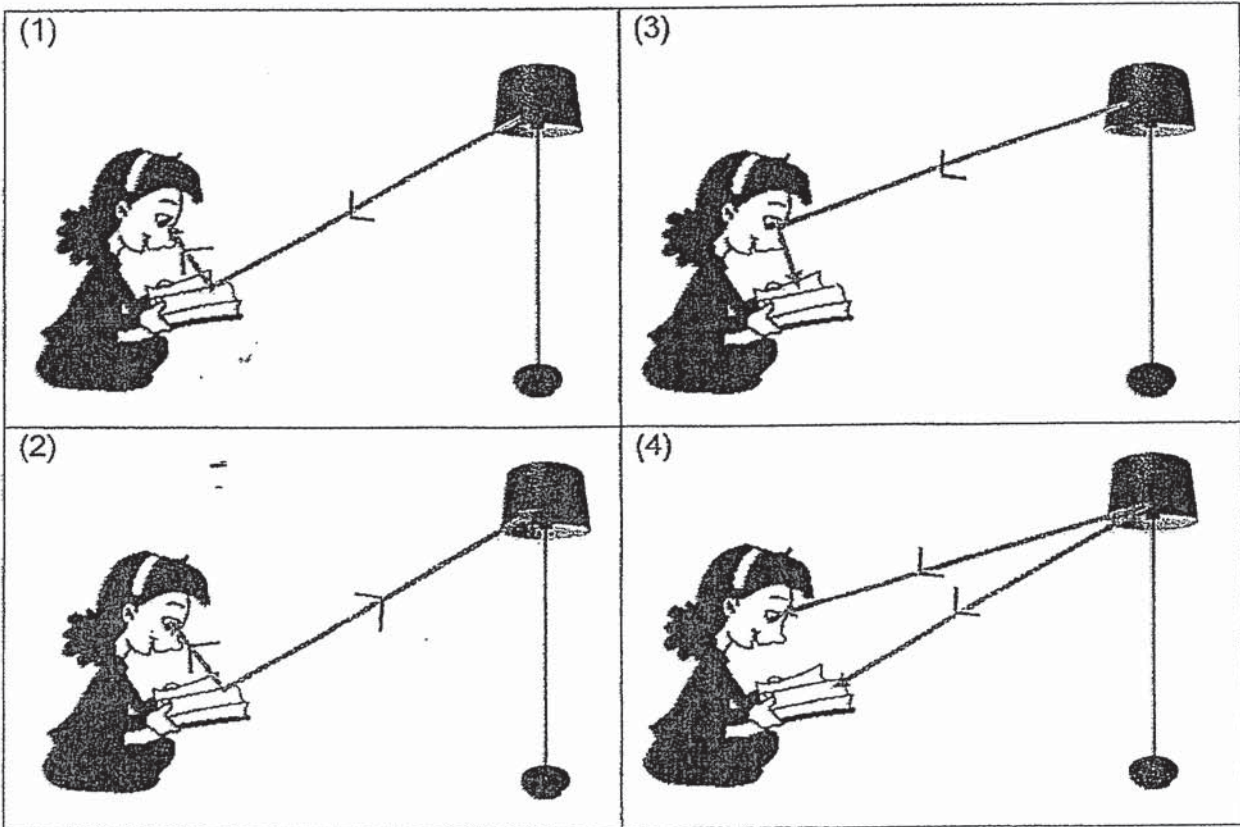

27. Observe the diagram below.

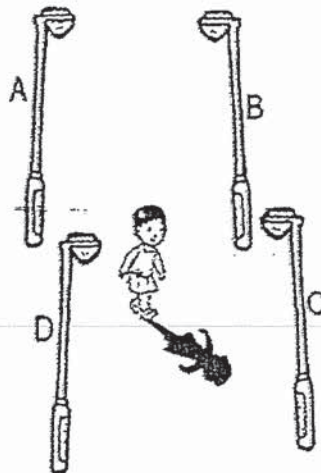

Which of the following street lamps, A, B, C or D, was lit up to cast the shadow shown above?

- (1) Street lamp A
- (2) Street lamp B
- (3) Street lamp C
- (4) Street lamp D



28. Danny wanted to conduct a light experiment. He glued 3 objects together as shown below and used a torch to shine on them.

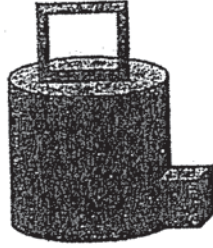

He turned the objects in several ways to form shadows. Which of the following is not a possible shadow formed by the objects above?

(1)

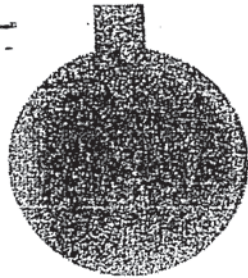

(3)



(2)



(4)



End of Booklet A  
Please check your work.

SINGAPORE CHINESE GIRLS' SCHOOL (PRIMARY)  
FIRST SEMESTRAL ASSESSMENT 2019

NAME: \_\_\_\_\_

DATE: 10 May 2019

CLASS: PRIMARY 5

SCIENCE

BOOKLET B

13 questions

44 marks

Total time for Booklets A & B: 1 h 45 min

**DO NOT OPEN THIS BOOKLET UNTIL YOU ARE TOLD TO DO SO.  
FOLLOW ALL INSTRUCTIONS CAREFULLY**

**Part II (44 marks)**

Answer all the following questions.

29. The diagram below shows the different states of water. A and B represent part of the processes when water changes from one state to another.

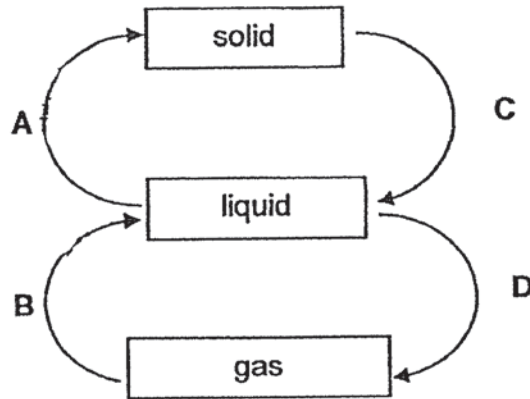

- (a) Identify the processes that take place at A and B. (1m)

Process A: \_\_\_\_\_

Process B: \_\_\_\_\_

- (b) Observe the following set-up.

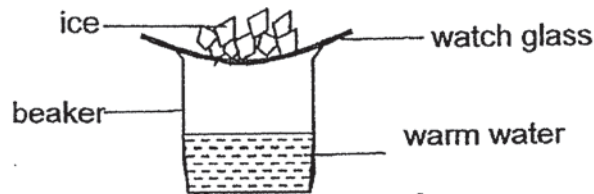

Water droplets are observed under the ~~water~~<sup>watch</sup> glass after a few minutes. Which one or more of the processes, A, B, C and/or D above, is/are involved in the formation of water droplets? (1m)

\_\_\_\_\_

- (c) Explain the difference between boiling and evaporation. (1m)

\_\_\_\_\_

\_\_\_\_\_

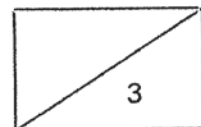

30. The picture below shows 2 similar trees, P and Q, with their roots.

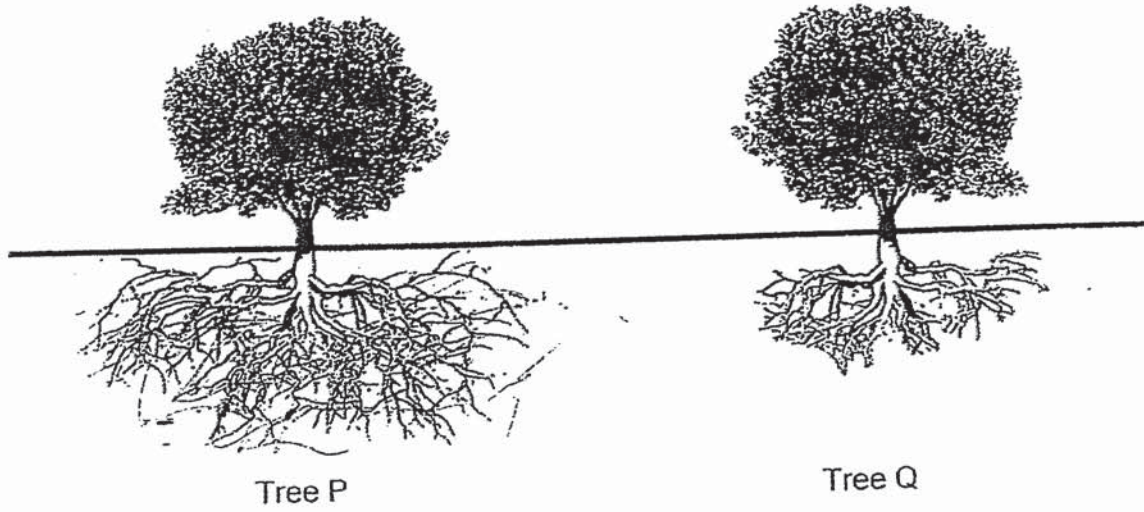

(a) On a windy day, which tree is more likely to topple? Explain your answer. (2m)

---

---

(b) How do the roots help the trees to stay alive? (1m)

---

---

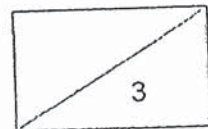

31. The diagram below shows a cross-section of a plant stem.

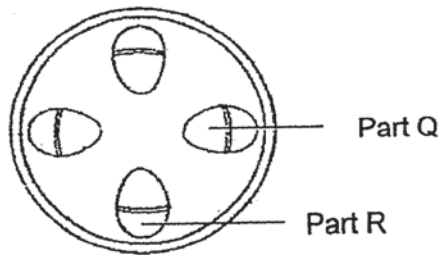

(a) Fill in the blanks below with 'Part Q' or 'Part R'. (1m)

Food-carrying tubes: \_\_\_\_\_

Water-carrying tubes: \_\_\_\_\_

(b) The picture below shows the plant.

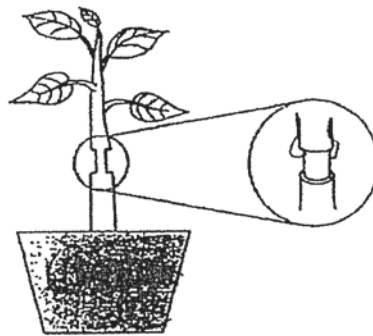

Outer ring containing Part R is removed.

The outer ring containing Part R is removed at the position shown in the diagram above.

Will the swelling of the stem be above or below the cut? Explain your answer. (2m)

---



---

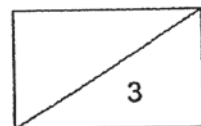

32. Diva wants to find out if the material of a nail affects the strength of an electromagnet. Materials A and B are both magnetic materials.

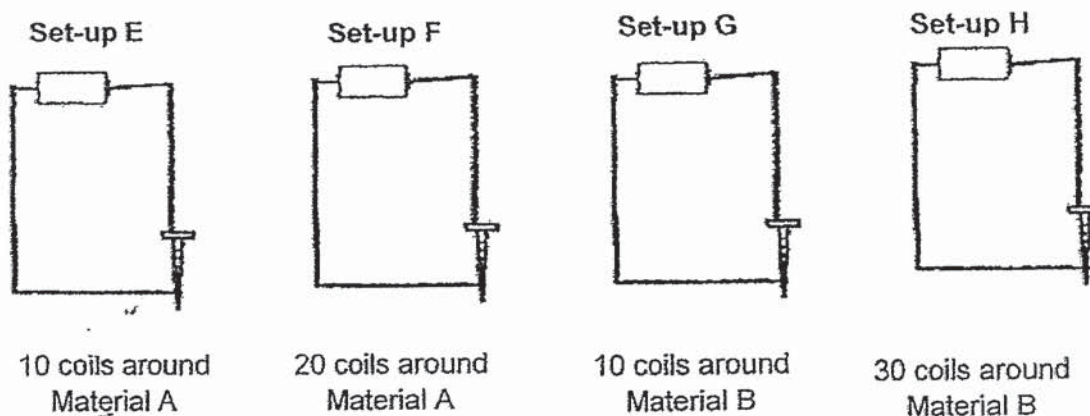

(i) Which 2 set-ups should she use? (1m)

---

(ii) Explain why Diva cannot use set-up E and H for the aim stated above? (1m)

---



---

(iii) Which 2 set-ups should she use if she wants to find out if the number of coils would affect the strength of an electromagnet? (1m)

---

(b) The diagram below shows the circuit diagram of an electric bell. When the switch is closed, the iron metal arm will hit the gong, causing the electric bell to ring.

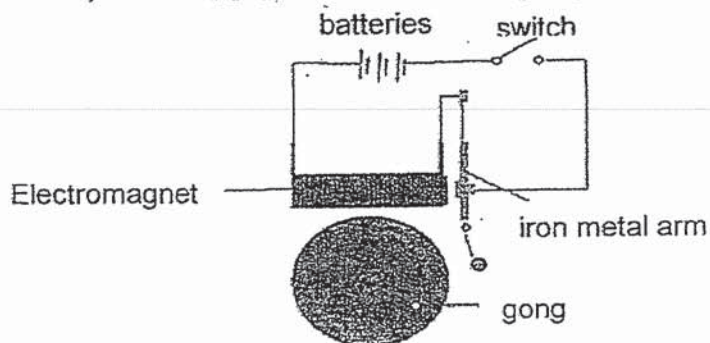

Explain why the bell will not ring when the iron metal arm is changed to an aluminium arm. (1m)

---

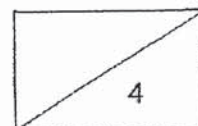

33. The diagram below shows the Lee family tree.

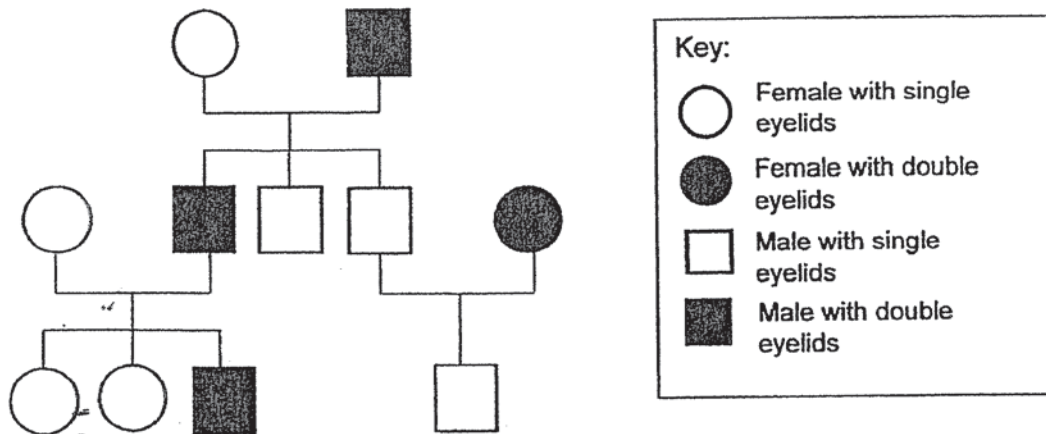

Kanis

Based on the diagram above,

(a) Who did Kanis inherit her single eyelids from? (1m)

\_\_\_\_\_

(b) How many sister/s does Kanis have? (1m)

Number of sisters: \_\_\_\_\_

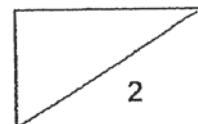

34. Jemimah observed the life cycle of a flowering plant as shown below.

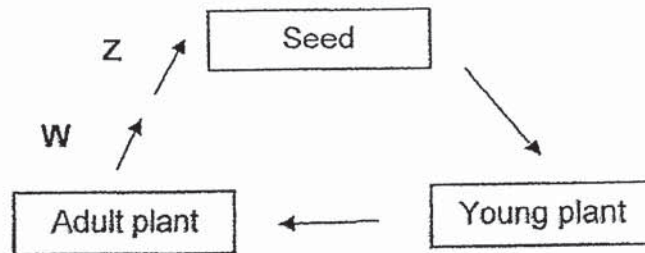

(a) Process W happens before Process Z. Name the 2 processes. (1m)

Process W: \_\_\_\_\_

Process Z: \_\_\_\_\_

(b) Fill in the blanks for Process W. (1m)

Transfer of \_\_\_\_\_ from the anthers to the \_\_\_\_\_ of the female part of a flower.

(c) Jemimah took 3 similar flowers, R, S and T, and removed different parts of the flower. None of the flowers were pollinated before the removal of the different parts. The table below shows the parts that were removed.

Flowers	Anthers	Stigma	Petal
R	Removed	Not removed	Removed
S	Removed	Removed	Not removed
T	Not removed	Not removed	Removed

Which flower/s will not be able to develop into fruits? Explain your answer. (2m)

---



---

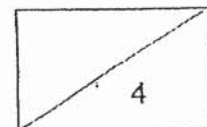



35. Diana observed 3 different types of plants A, B and C on a piece of land. A year later, she observed the same piece of land again.

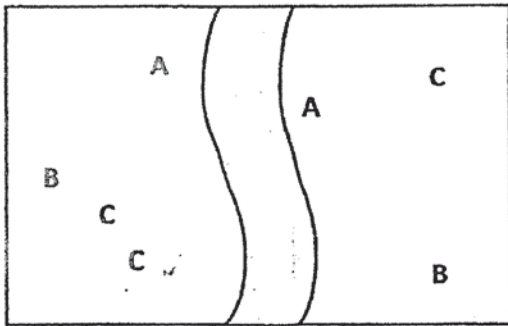

First observation

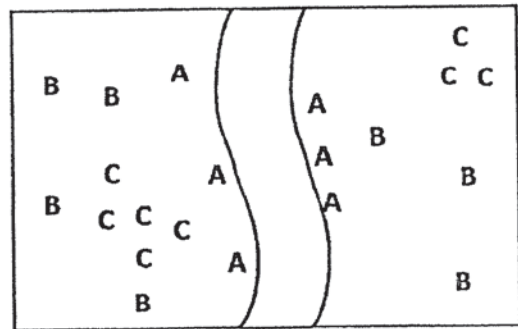

Second observation

- (a) Identify the methods of seed dispersal of Plants A, B and C. (1.5m)

Plant A: \_\_\_\_\_

Plant B: \_\_\_\_\_

Plant C: \_\_\_\_\_

- (b) The diagram below shows the fruits of Plant Z. The fruits are edible with indigestible seeds.



Which of the plants, A, B or C, best represents Plant Z? (0.5m)

\_\_\_\_\_

- (c) In the year 2015, on an isolated island, there were no Plants A, B and C. In the year 2016, out of the 3 types of plants, only 2 types were found there. Which of the plants, A, B or C, was not found there? Explain. (2m)

\_\_\_\_\_

\_\_\_\_\_

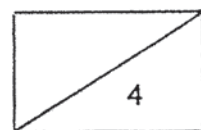

36. Jo placed a piece of plasticine into a beaker of water containing 100ml. Then she broke the same plasticine into smaller pieces and placed them back into the beaker of water.

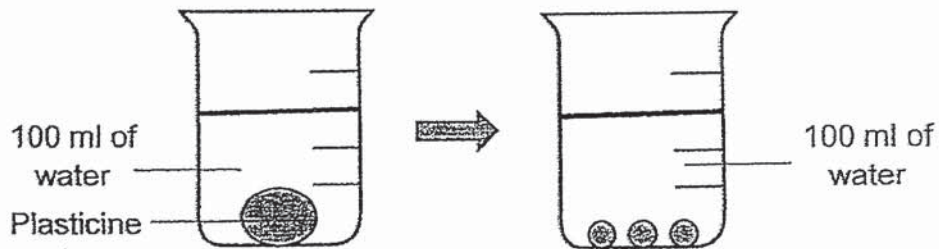

- (a) Jo observed that there was no change to the water level in the beaker. Explain her observations. (1m)

---



---

- (b) Jo conducted another experiment. She took  $100\text{cm}^3$  of water and poured it into a beaker containing  $100\text{cm}^3$  of sand.

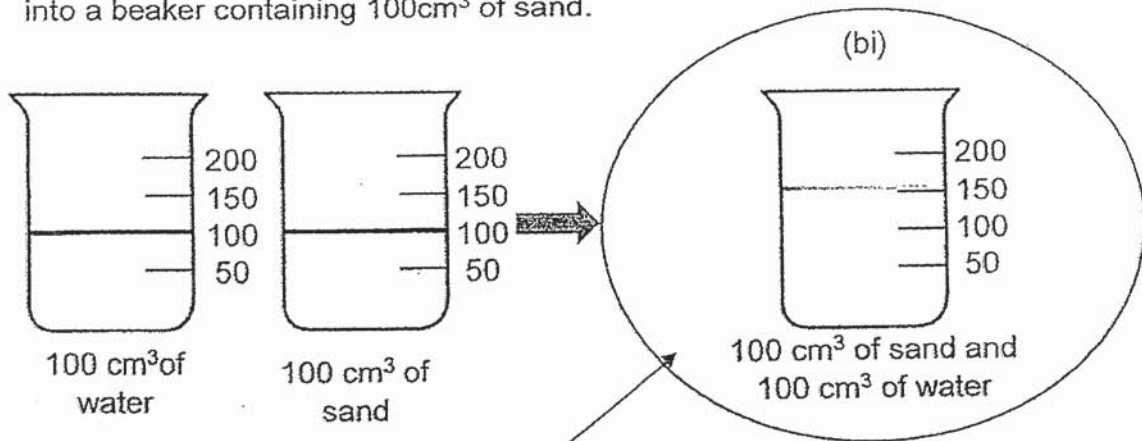

- (bi) Draw the volume that Jo is likely to observe when the water is poured into the beaker of sand. (1m)

- (bii) Explain Jo's observation. (1m)

---



---

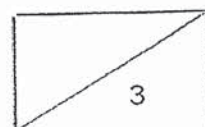

37. Mrs Thiri placed 100ml of water into 3 identical glasses F, G and H. Each glass has water of a different temperature.



5 minutes later, she observed that water droplets formed on the outer surface of the glasses. She recorded the results in the table below.

Glass	Number of water droplets formed
F	20
G	10
H	6

- (a) Which of the glasses contains water of the lowest temperature? (1m)

Glass:

- (b) Explain how water droplets formed on the outer surface of the glasses. (2m)

---



---



---

- (c) Mrs Thiri observed that no more water droplets form after the temperature of water in all the glasses was increased to room temperature. Explain why. (2m)

---



---

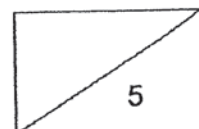

38. The diagram below shows 2 identical cups, J and K, with the same volume of water. 1 big ice cube was placed in Cup J. Another ice cube of the same volume was crushed into smaller pieces before placing in Cup K, as shown below.

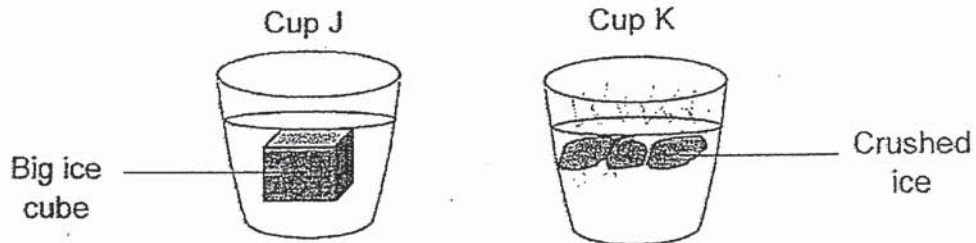

- (a) Which cup will have colder water after 5 minutes? Explain your answer. (2m)

---



---



---

- (b) A beaker of liquid was heated and the temperature of the liquid was recorded in the graph below.

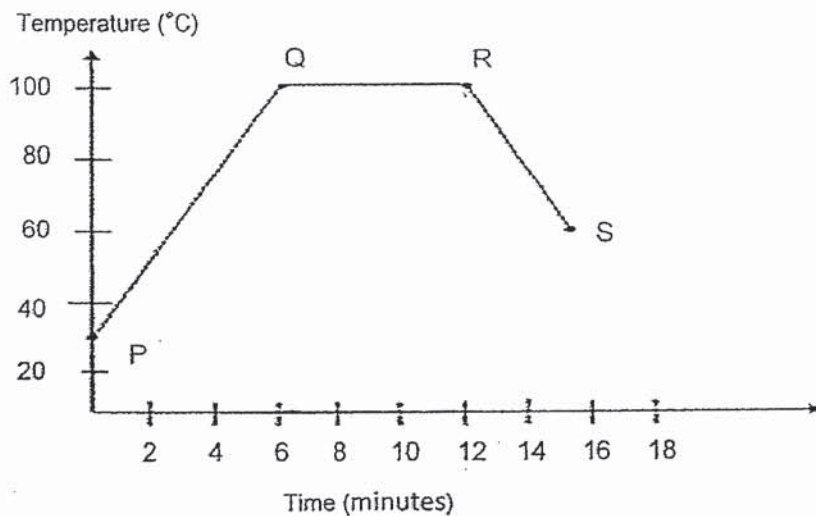

Put a tick (✓) in the correct column. (2m)

Statements	True	False
There is no heat gain from Q to R.		
Water was heated for 6 minutes.		
The boiling point of the liquid is 100°C.		
There is a change in state from Q to R.		

39. Poppy washed some plates and stacked the wet plates facing downwards on the table as shown below.

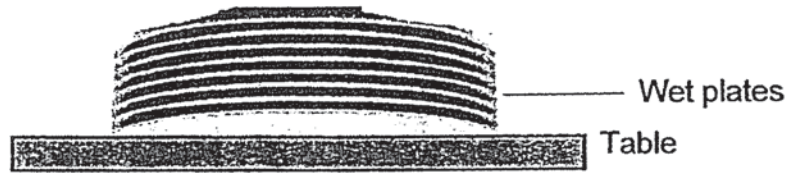

Poppy's mother saw the wet plates and rearranged them on a holder as shown below.

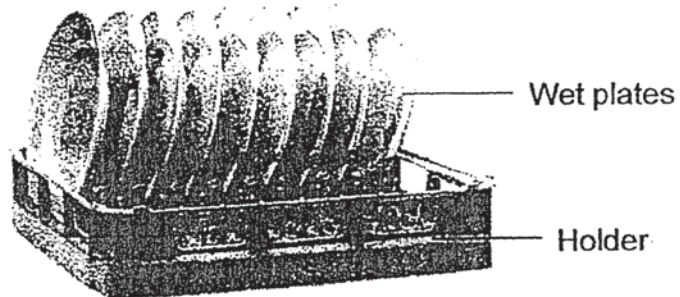

Explain how the new arrangement will allow the plates to dry faster. (2m)

---

---

---

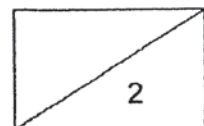

40. Kira has 2 cups of similar sizes as shown below. Cup G is made of plastic while Cup H is made of metal.



Plastic cup G



Metal cup H

- (a) If Kira wants to keep her hot milo as hot as possible, which cup should she use? Explain your answer. (2m)

---

---

---

- (b) Kira took out a pot from a cupboard. She touched the plastic handles and metal base of the pot and felt that the metal base of the pot is cooler.



Plastic handles

Metal base

- (i) She measured the temperature of the handles and it is similar to the room temperature ( $28^{\circ}\text{C}$ ). What is the temperature of the metal base of the pot? (1m)

---

- (ii) Explain why the metal base of the pot feels cooler to her hands than the plastic handles. (1m)

---

---

---

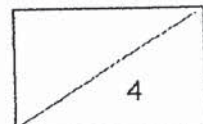

41. Mr Kumar set up the experiment as shown below.

Distance N represents the distance between the torch and the object.  
Distance L represents the distance between the object and the wall.

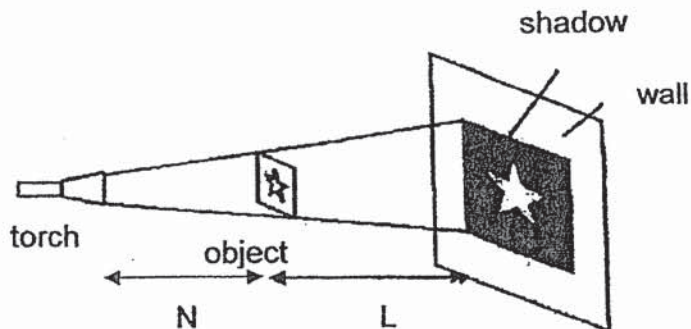

He changed Distance N and Distance L and recorded the height of the shadow formed in the table below.

Distance N (cm)	Distance L (cm)	Height of shadow (cm)
6	6	10
(ai)	6	14
8	4	(aii)

(a) Complete the table above. (1m)

(b) The object was made up of 2 different materials as shown below.

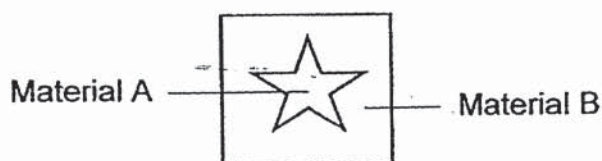

Put a tick ( ✓ ) in the correct column. (2m)

	Transparent	Translucent	Opaque
Material A			
Material B			

End of Booklet B

Please check your work.

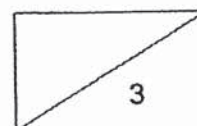





SINGAPORE CHINESE GIRLS' PRIMARY SCHOOL  
P5 SEMESTRAL ASSESSMENT 1 (SCIENCE) 2019  
Model Answer

1) 3	6) 2	11) 1	16) 3	21) 1	26) 1
2) 4	7) 3	12) 2	17) 4	22) 2	27) 1
3) 4	8) 3	13) 4	18) 1	23) 3	28) 3
4) 2	9) 1	14) 4	19) 4	24) 2	
5) 2	10) 3	15) 1	20) 4	25) 2	

Qn	Model Answer
29a	Process A: <u>Freezing</u> Process B: <u>Condensation</u>
29b	B and D
29c	Boiling takes place at a fixed temperature but evaporation takes at any temperature.
30a	Tree Q. Tree Q has less/shorter roots so the tree is anchored less firmly to the ground.
30b	Roots take in water from the soil to stay alive.
31a	Food-carrying tubes: <u>Part R</u> Water-carrying tubes: <u>Part Q</u>
31b	Above the cut. Food made by the leaves could not be transported down beyond the cut.
32ai	E and G
32aii	It is not a fair test. The number of coils is changed when it is supposed to be a controlled variable.
32aiii	E and F / G and H
32b	Aluminium is a non-magnetic material.
33a	Mother
33b	
34a	Process W: <u>Pollination</u> Process Z: <u>Fertilisation</u>
34b	Transfer of <u>pollen grains</u> from the anther to the <u>stigma</u> of the female part of a flower.
34c	Flower S. Without stigma, the flower cannot be pollinated and fertilised.
35a	Plant A: <u>By water</u> Plant B: <u>By animals/wind</u> Plant C: <u>By splitting</u>

Qn	Model Answer			
35b	Plant B			
35c	Plant C. C dispersed its seeds by splitting, thus its seeds can only be dispersed at short distances away from the parent plant.			
36a	Plasticine has a definite volume.			
36bi	Volume must be above 100cm <sup>3</sup> but less than 200cm <sup>3</sup> , eg. 150cm <sup>3</sup>			
36bii	The water took up the space previously occupied by the air spaces between the sand.			
37a	F			
37b	Warmer water vapour in the surrounding air lost heat and condenses on the cooler outer surface of the glasses to form water droplets.			
37c	The glass surface was not cool enough for water vapour in the surrounding air to condense into water droplets. / There is no significant temperature difference between the water in the glasses and the water vapour in the surrounding air to condense into water droplets.			
38a	Cup K. The crushed ice has a greater surface area in contact with the water so water in Cup K lost heat faster to the ice.			
38b	Statements	True	False	
	There is no heat gain from Q to R.	\	✓	
	Water was heated for 6 minutes.		✓	
	The boiling point of the liquid is 100°C.	✓		
	There is a change in state from Q to R.	✓		
39	When the wet plates are arranged in the holder, there is a greater exposed surface area of the wet plates to the surrounding air so the rate of evaporation is higher to make the plates will dry faster.			
40a	Plastic is a poorer conductor of heat than metal so heat will be conducted from the to the surrounding air slower.			
40bi	Ans: 28°C			
40bii	Metal is a better conductor of heat than plastic so heat is conducted from her hands to the metal base faster.			
41a	(ai) 1-5cm (aii) 5-9cm			
41b		Transparent	Translucent	Opaque
	Material A	✓		
	Material B			✓

2  
END