

Name : _____ ()

Class : Primary 5 _____

CHIJ ST NICHOLAS GIRLS' SCHOOL

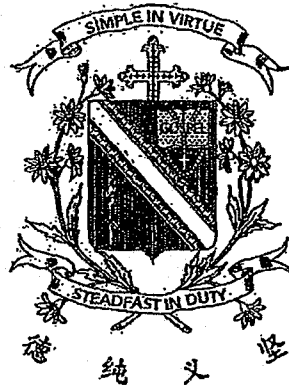

Primary 5

Semestral Assessment 1

SCIENCE

BOOKLET A

10 May 2018

Total Time for Booklets A and B: 1 hour 45 minutes

**28 questions
56 marks**

**Do not open this booklet until you are told to do so.
Follow all instructions carefully.**

This paper consists of 17 printed pages.

Section A (28 x 2 marks = 56 marks)

For each question from 1 to 28, four options are given. One of them is the correct answer. Make your choice (1, 2, 3 or 4). Shade the correct oval (1, 2, 3 or 4) on the Optical Answer Sheet provided.

1. Study the table below.

| Function | Part of the human digestive system | | | |
|--|------------------------------------|---|---|---|
| | E | F | G | H |
| Digestion takes place here | ✓ | ✓ | | ✓ |
| Digested food is absorbed into the bloodstream | | ✓ | | |
| Solid waste is passed out of the body | | | ✓ | |

| |
|------------|
| Key |
| ✓ present |

Which one of the following correctly shows the parts labelled E, F, G and H?

(1)

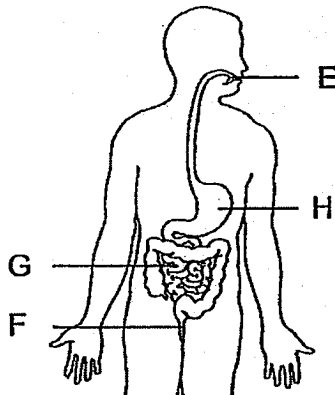

(2)

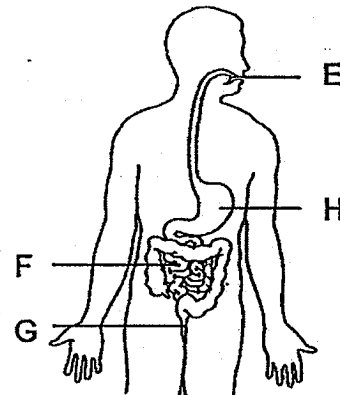

(3)

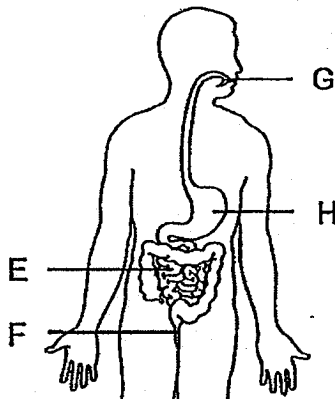

(4)

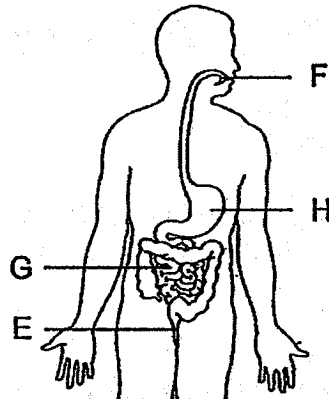

2. Study the chart below.

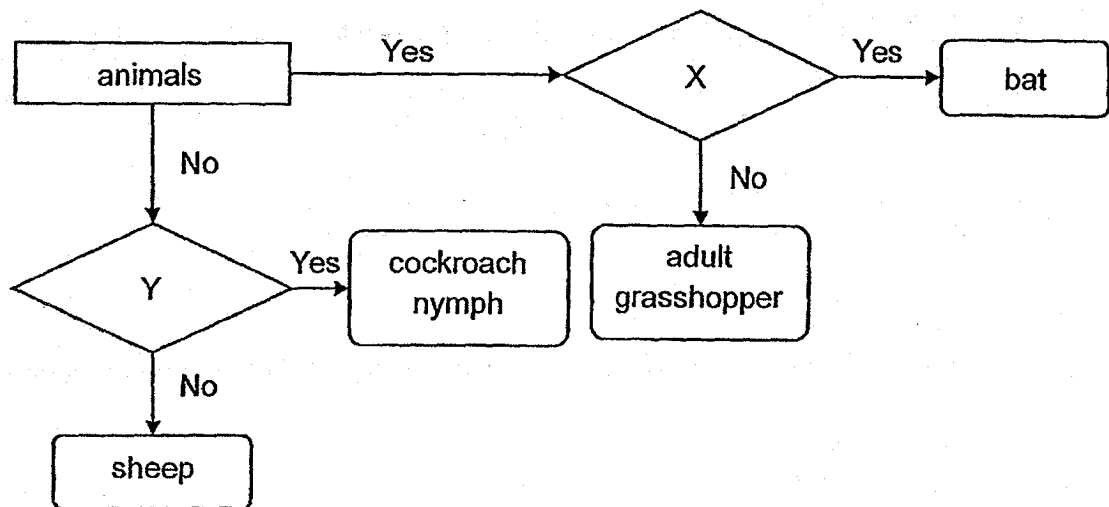

Which of the following shows the characteristics represented by X and Y?

| Characteristics | |
|----------------------------|--------------------------------|
| X | Y |
| (1) lays eggs | has 3 body parts |
| (2) breathes through lungs | has 3 body parts |
| (3) has 6 legs | gives birth to its young alive |
| (4) has feathers | gives birth to its young alive |

3. What is generally common among birds and fish?

- (1) They can swim.
- (2) They can reproduce by laying eggs.
- (3) They have the same outer covering.
- (4) They have the same breathing method.

4. Study the diagram shown below.

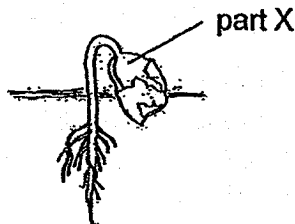

What is the function of part X?

- (1) It provides air for the young plant.
- (2) It provides food for the young plant.
- (3) It provides water for the young plant.
- (4) It provides protection for the young plant.

5. A, B, C and D represents the different stages in the life cycle of a butterfly.

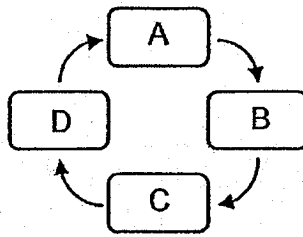

If B represents the adult stage of the butterfly, what stage does D represent?

- (1) Egg
- (2) Larva
- (3) Pupa
- (4) Nymph

6. The diagram below shows movement of substances A and B in a cell.

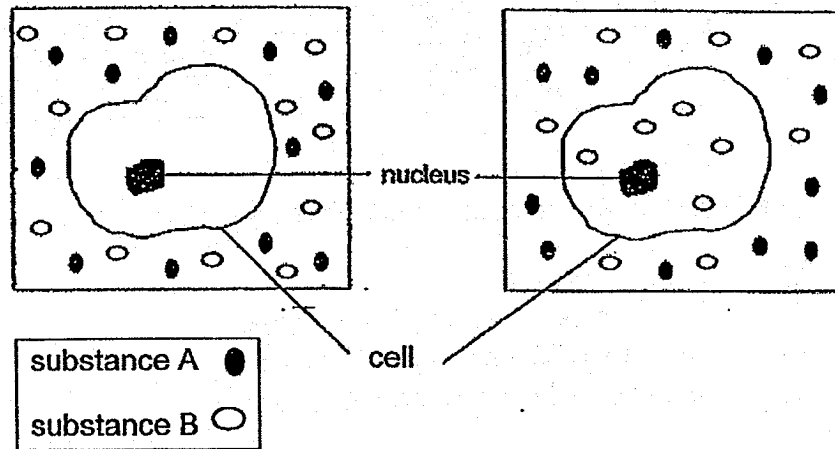

Which one of the following best explains the above observation?

- (1) The cell membrane of the cell only allows substance A to pass through.
- (2) The cell membrane of the cell only allows substance B to pass through.
- (3) The cell membrane of the cell allows substance A and B to pass through.
- (4) The cell membrane of the cell does not allow any substances to pass through.

7. Study the diagram below.

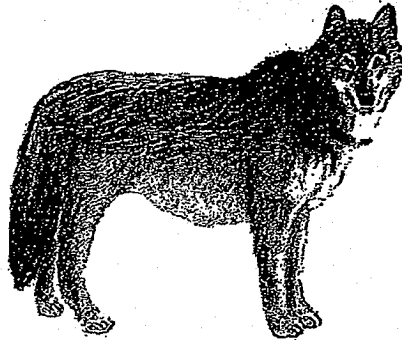

organism W



organism S

Which of the following statement(s) about the organisms is/are true?

- A Organism W has more cells than organism S.
- B Both organisms have cells that carry out different functions.
- C Organism W is bigger than organism S because its cells are much larger.

- (1) B only
- (2) A and C only
- (3) A and B only
- (4) B and C only

8. The table below lists the parts of a cell. Each tick (✓) represents the part of a cell that cells G, H and J have.

| Part of the cell | Cell G | Cell H | Cell J |
|------------------|--------|--------|--------|
| Cell Membrane | ✓ | ✓ | ✓ |
| Cell Wall | ✓ | | ✓ |
| Chloroplasts | ✓ | | |
| Nucleus | ✓ | ✓ | ✓ |

Where are cells G, H and J likely to be found?

| | Cell G | Cell H | Cell J |
|-----|--------|--------|--------|
| (1) | cheek | leaf | root |
| (2) | root | cheek | leaf |
| (3) | leaf | root | cheek |
| (4) | leaf | cheek | root |

9. The diagram below shows some fruit flies kept in a sealed jar.

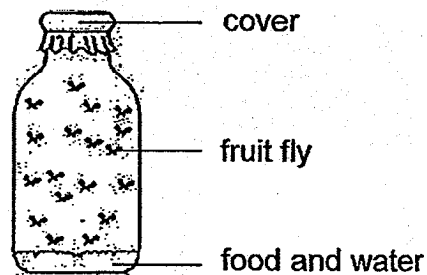

Which of the following correctly shows the changes in the amount of gases in the jar after five hours?

| | Carbon dioxide | Oxygen | Nitrogen | Water vapour |
|-----|----------------|----------|-----------------|-----------------|
| (1) | decrease | increase | decrease | remain the same |
| (2) | increase | decrease | remain the same | decrease |
| (3) | decrease | increase | increase | remain the same |
| (4) | increase | decrease | remain the same | increase |

10. Study the lung-model below.

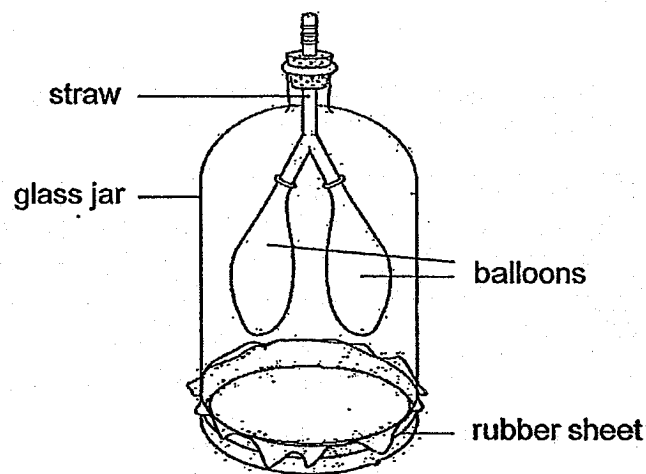

Which one of the following correctly matches the parts of the lung-model to the human respiratory system?

| | Balloons | Rubber sheet | Straw |
|-----|-----------|--------------|----------|
| (1) | heart | diaphragm | gullet |
| (2) | lungs | heart | gullet |
| (3) | lungs | diaphragm | windpipe |
| (4) | diaphragm | lungs | windpipe |

11. The diagram shows the direction of blood flow in some parts of the body.

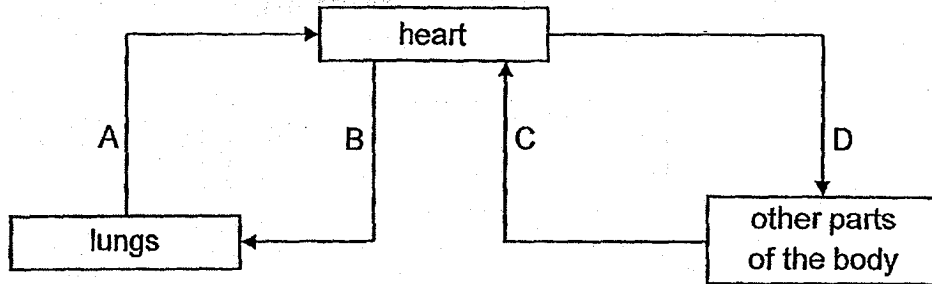

Which chart shows the correct comparison of the amount of carbon dioxide in the blood samples?

(1) Amount of Carbon dioxide

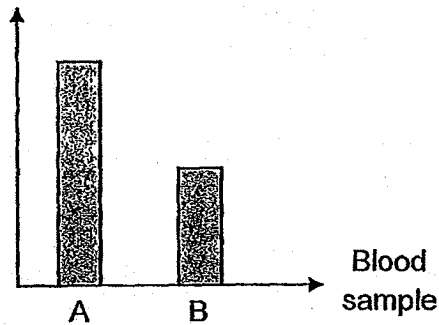

(2) Amount of Carbon dioxide

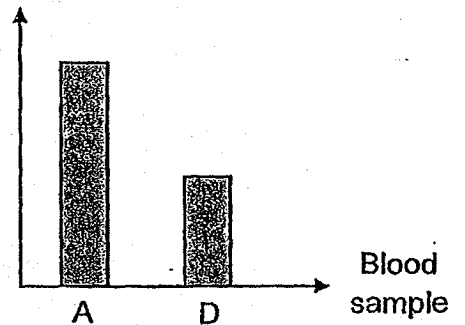

(3) Amount of Carbon dioxide

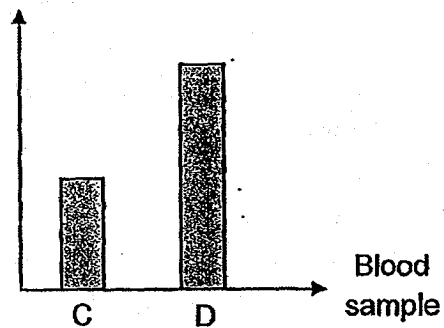

(4) Amount of Carbon dioxide

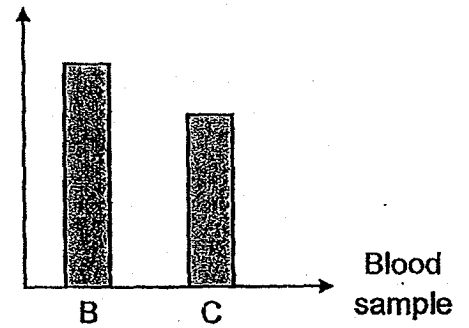

12. The table below shows Steve's pulse rate when he carries out three different activities.

| Activity | Pulse rate per minute |
|----------|-----------------------|
| E | 60 |
| F | 75 |
| G | 105 |

Which of the following is likely to represent the three activities correctly?

| | E | F | G |
|-----|-----------------------|-----------------------|-----------------------|
| (1) | sleeping | strolling in the park | playing basketball |
| (2) | playing hockey | strolling in the park | sleeping |
| (3) | reading a book | playing badminton | strolling in the park |
| (4) | strolling in the park | playing netball | reading a book |

13. Which one of the following comparisons between the human circulatory system and the plant transport system is correct?

| | Human circulatory system | Plant transport system |
|-----|---|--|
| (1) | does not transport gases | transports gases |
| (2) | substances moves in two directions | substances moves in one direction |
| (3) | has an organ to pump substances around the body | does not have an organ to pump substances around the plant |
| (4) | has only one tube to carry substances around the body | has one tube to carry food and one tube to carry water |

14. Arron put a plant in a beaker of blue-coloured water for 24 hours. The diagram below shows a section of the stem after 24 hours.

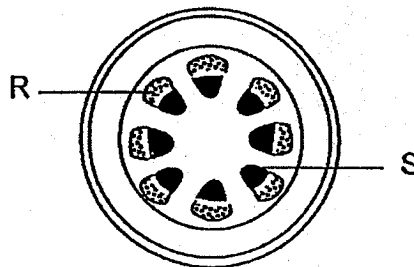

Arron observed that tube S turned blue but not tube R. Which of the following is a possible explanation for this observation?

- (1) Tube S transports food from the roots to all parts of the plant.
- (2) Tube S transports water from the roots to all parts of the plant.
- (3) Tube S transports food from the leaves to all parts of the plant.
- (4) Tube S transports water from the leaves to all parts of the plant.

15. An outer ring of a stem was removed from a plant as shown below. As a result, the tubes carrying food and water were removed.

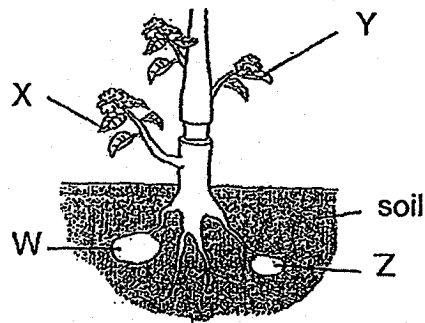

It was observed that part W of the plant grew bigger after one week.

Which of the following statement(s) best explains this observation?

- A Food at Z is transported to W.
- B Food made by X is transported to W.
- C Food made by Y is transported to W.
- D W absorbs water and becomes bigger.

- (1) B only
- (2) A and D only
- (3) B and C only
- (4) C and D only

16. The diagram below shows a car.

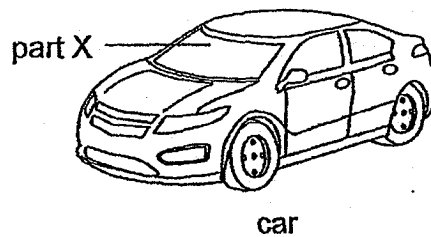

Part X helps to keep the rain away and allows the driver of the car to see the road ahead clearly.

Which of the following best represents the properties of part X?

| Properties of part X | |
|----------------------|------------------------------|
| waterproof | allows light to pass through |
| (1) yes | yes |
| (2) yes | no |
| (3) no | yes |
| (4) no | no |

17. Study the diagram below.

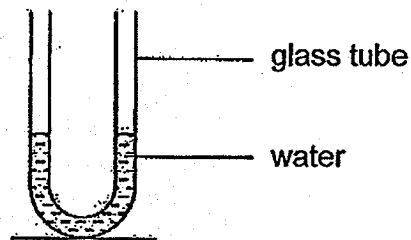

Which one of the following diagrams shows how the water in the tube would look like when the glass tube is tilted?

(1)

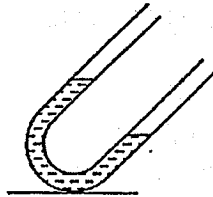

(2)

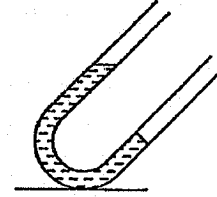

(3)

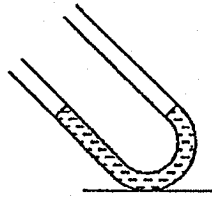

(4)

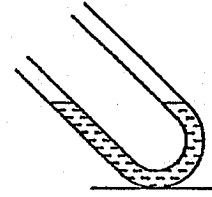

18. The diagram below shows a syringe connected to a glass jar. The capacity of the glass jar is 500 cm^3 .

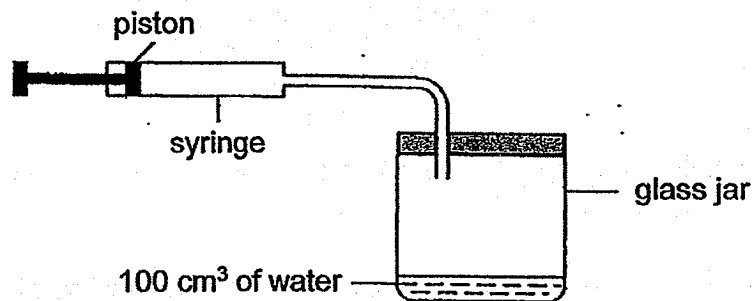

When the piston is pushed in completely, another 90 cm^3 of air is forced into the jar. What is the volume of air in the jar?

- (1) 90 cm^3
- (2) 400 cm^3
- (3) 490 cm^3
- (4) 500 cm^3

19. The set-ups below show two similar containers with water at different temperatures. Both containers were left on the table for 30 minutes.

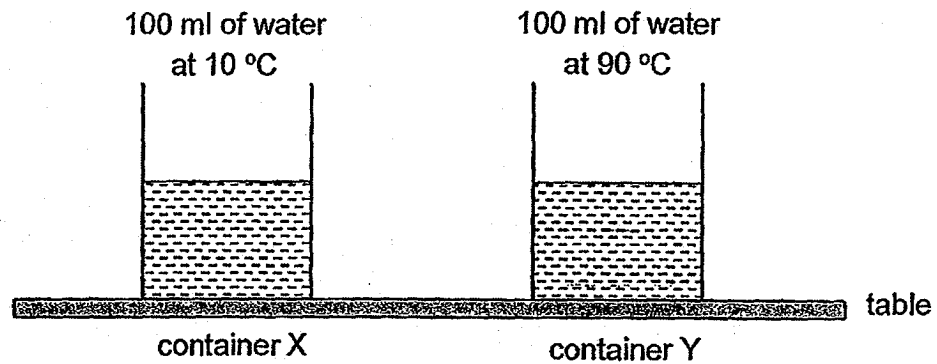

Which one of the following table shows what happened to the water in the containers after 30 minutes?

(1)

| | Gained heat | Lost heat | Temperature |
|----------------------|-------------|-----------|-------------|
| Water in container X | ✓ | | Increased |
| Water in container Y | | ✓ | Decreased |

(2)

| | Gained heat | Lost heat | Temperature |
|----------------------|-------------|-----------|-------------|
| Water in container X | ✓ | | Increased |
| Water in container Y | ✓ | | Decreased |

(3)

| | Gained heat | Lost heat | Temperature |
|----------------------|-------------|-----------|-------------|
| Water in container X | | ✓ | Increased |
| Water in container Y | | ✓ | Increased |

(4)

| | Gained heat | Lost heat | Temperature |
|----------------------|-------------|-----------|-------------|
| Water in container X | | ✓ | Decreased |
| Water in container Y | ✓ | | Decreased |

20. Study the set-ups below.

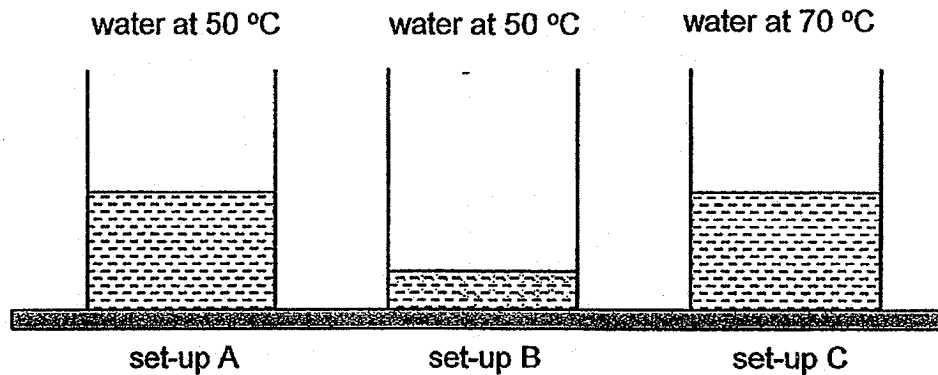

Which one of the following shows the correct order of increasing amount of heat in the water for set-ups A, B and C?

| | least amount of heat → most amount of heat | | |
|-----|---|---|---|
| (1) | B | A | C |
| (2) | C | A | B |
| (3) | C | B | A |
| (4) | A | B | C |

21. Study the table below.

| Metal | Temperature before heating (°C) | Temperature after heating (°C) |
|-------|---------------------------------|--------------------------------|
| S | 20 | 90 |
| T | 24 | 79 |
| U | 21 | 87 |
| V | 25 | 69 |

Which metal S, T, U or V is most suitable for making the base of a frying pan?

- (1) S
- (2) T
- (3) U
- (4) V

22. Najmi used the set-up below to conduct an experiment on shadows in a dark room. He used a light sensor to measure the amount of light on the screen.

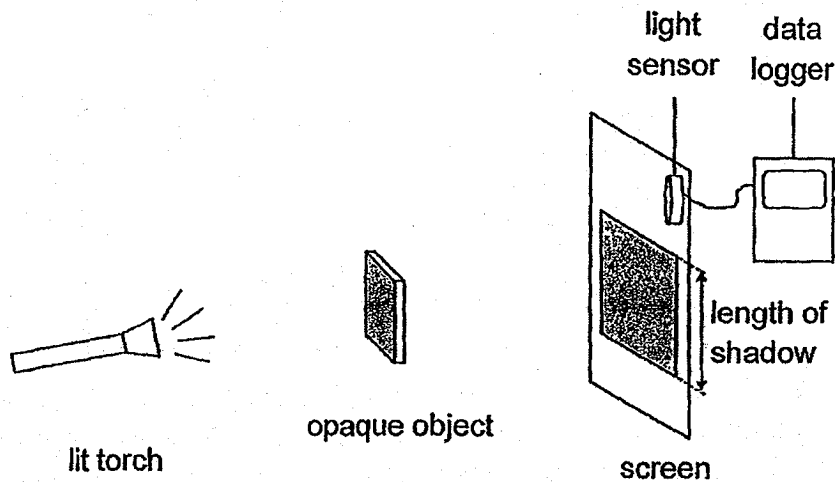

He changed the position of one of the items in the set-up and recorded his observations for each position as follows.

| Length of shadow (cm) | Light sensor reading (units) |
|-----------------------|------------------------------|
| 20 | 120 |
| 17 | 170 |
| 11 | 260 |
| 9 | 300 |

What change did Najmi make?

- (1) Object was moved towards the torch.
- (2) Torch was moved towards the object.
- (3) Screen was moved towards the object.
- (4) Object was moved away from the screen.

23. Cheng Yee wanted to find out which material could reflect the most light. He conducted the following experiment in a dark room.

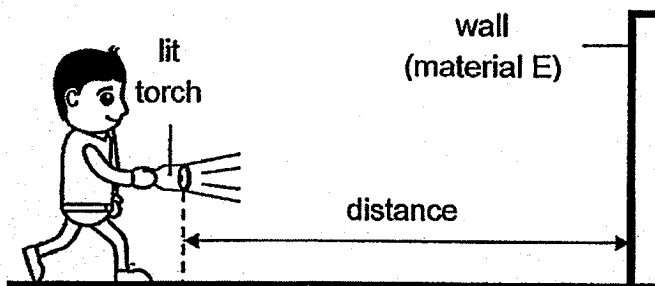

He shone the torch onto material E and walked towards it. When he could see the material clearly, he stopped and recorded the distance between the torch and the material. He repeated this experiment using materials F, G and H and recorded the results in the table below.

| Material | E | F | G | H |
|---------------|----|-----|-----|-----|
| Distance (cm) | 80 | 120 | 160 | 200 |

Which one of the following statements is correct?

- (1) Material E is better at reflecting light than material H.
 - (2) Material G is better at reflecting light than material F.
 - (3) Material H is poorer at reflecting light than material E.
 - (4) Material F is poorer at reflecting light than material E.
24. Siti tried to attract some steel clips using a nail which had been stroked by a bar magnet. She observed that no steel clips were attracted. Which of the following could be possible reason(s) for this observation?

- A The nail was made of copper.
- B The nail was stroked by the south pole of the bar magnet only.
- C The nail was stroked many times in the same direction with the same pole of the bar magnet each time.
- D The nail was stroked many times in different directions with the same pole of the bar magnet each time.

- (1) A only
- (2) B only
- (3) A and D only
- (4) B and C only

25. Calista set up the circuit as shown below. She arranged two identical bulbs in box D. When she closed the circuit, both bulbs lit up.

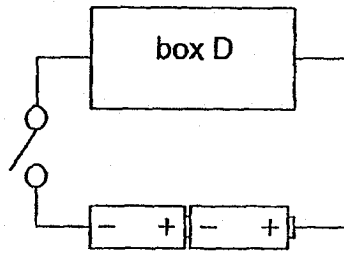

Which one of the following arrangements of bulbs in box D is not possible?

(1)

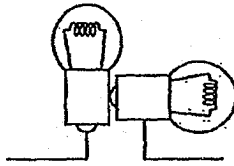

(2)

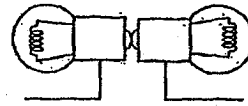

(3)

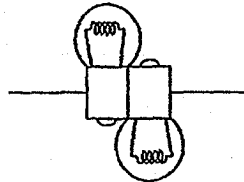

(4)

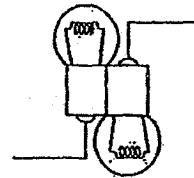

26. Firdaus set up a circuit as shown below. All the five identical bulbs lit up when all switches A, B and C were closed.

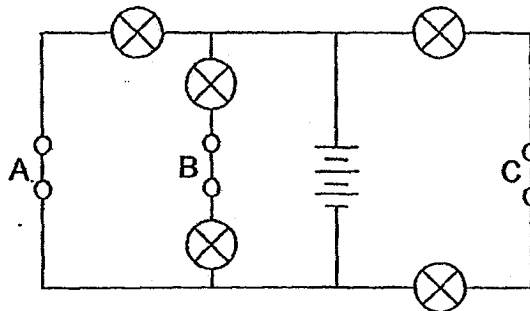

Which of the following switch(es) should be opened in order to have the least number of bulbs lit?

- (1) B only
- (2) C only
- (3) A and B only
- (4) B and C only

27. Three rods P, Q and R each made of a different material were connected in a circuit as shown below.

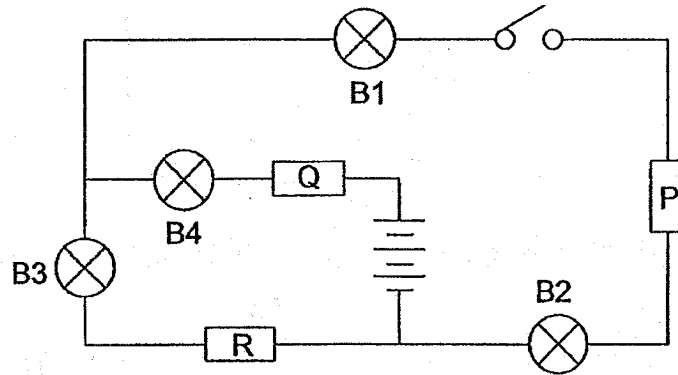

The table below shows the results when the switch was closed.

| Did the bulb light up? | | | |
|------------------------|-----|----|-----|
| B1 | B2 | B3 | B4 |
| yes | yes | no | yes |

Which of the following describes P, Q and R correctly?

| | P | Q | R |
|-----|-----------|-----------|-----------|
| (1) | conductor | insulator | conductor |
| (2) | conductor | conductor | insulator |
| (3) | insulator | insulator | conductor |
| (4) | insulator | conductor | insulator |

28. Chee Hsiang was given a circuit card and a circuit tester as shown below. When one end of the circuit tester was clipped onto A and the other end onto D, the bulb lit up.

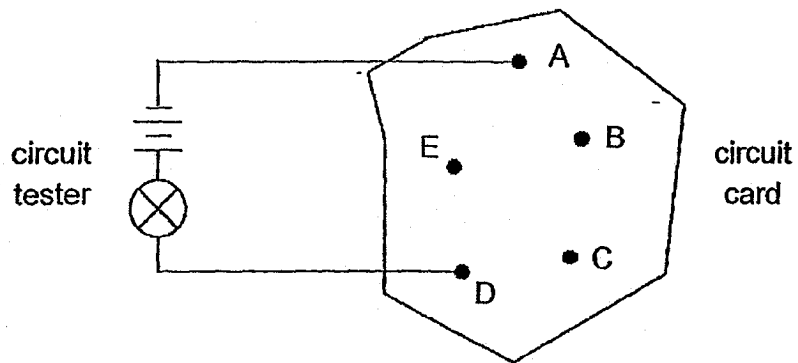

Which one of following connections correctly shows how the wires are connected on the reverse side of the circuit card?

(1)

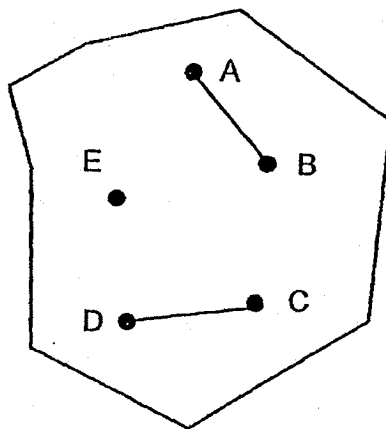

(2)

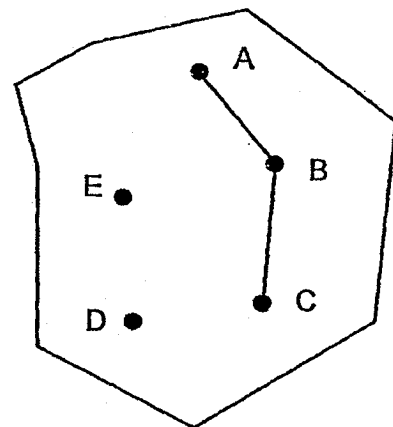

(3)

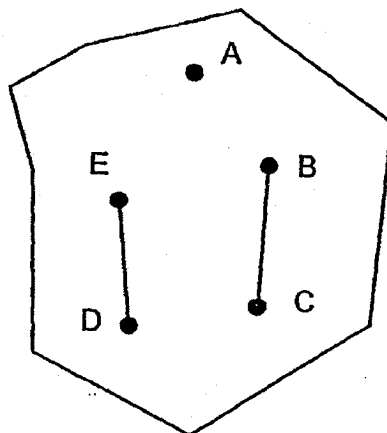

(4)

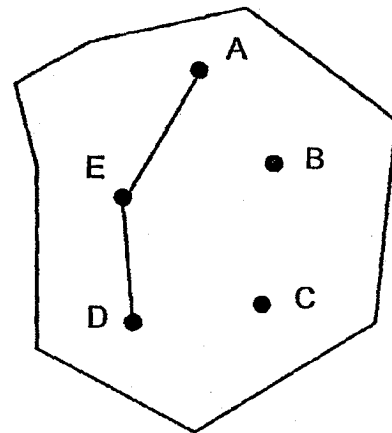

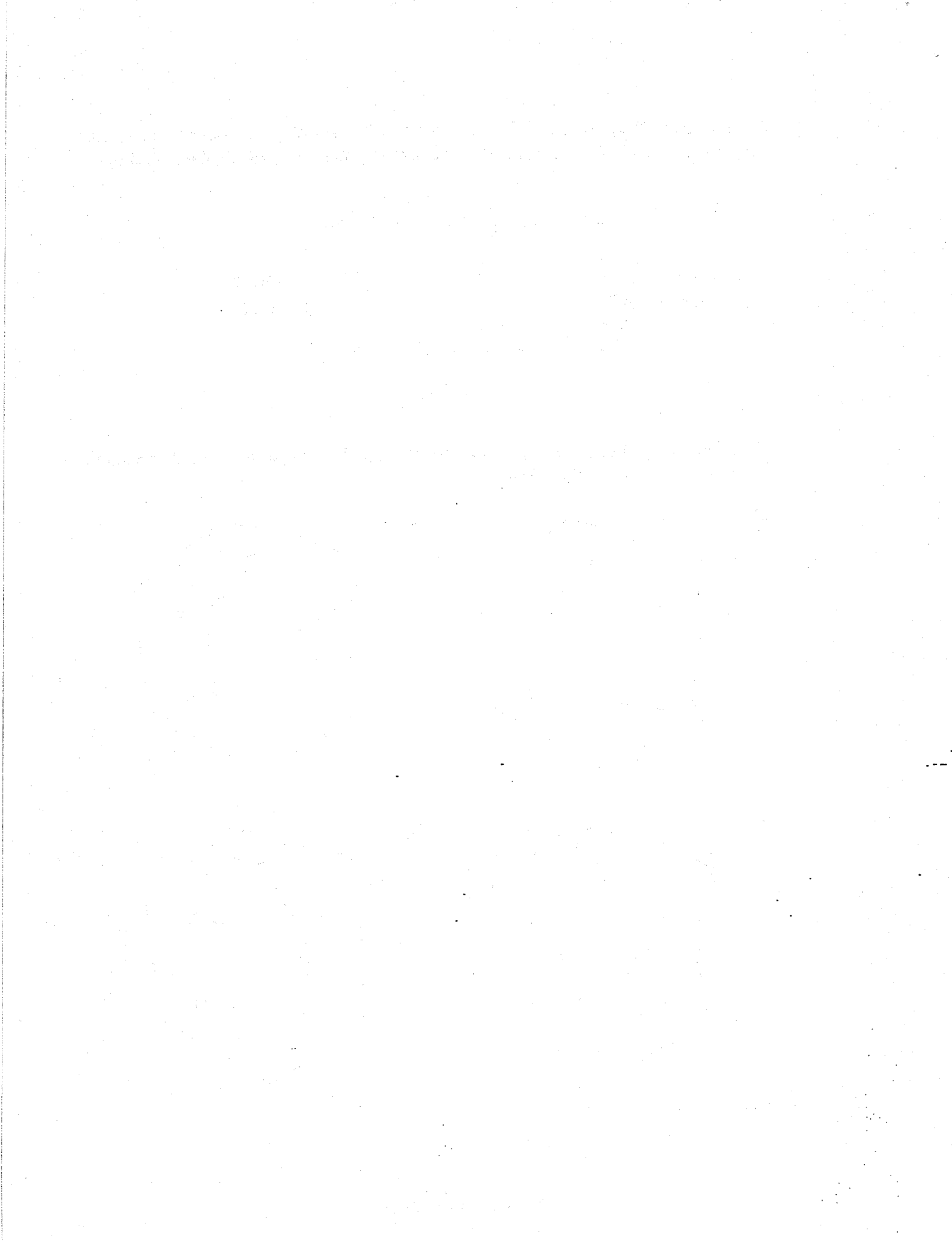

Name : _____)

Class : Primary 5 _____

CHIJ ST NICHOLAS GIRLS' SCHOOL

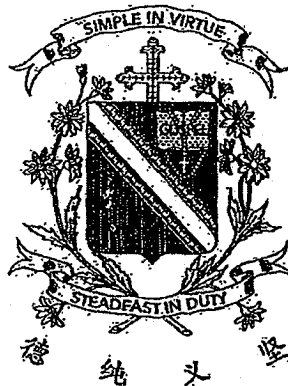

Primary 5

Semestral Assessment 1

SCIENCE

BOOKLET B

10 May 2018

Total Time for Booklets A and B: 1 hour 45 minutes

13 questions
44 marks

Do not open this booklet until you are told to do so.
Follow all instructions carefully.
Answer all questions.

| | |
|-----------|-----|
| Booklet A | 56 |
| Booklet B | 44 |
| Total | 100 |

This booklet consists of 16 printed pages.

Parent's Signature/Date

Section B (44 marks)

For questions 29 to 41, write your answers in this booklet. The number of marks available is shown in the brackets at the end of each question or part question.

29. Study the chart below carefully.

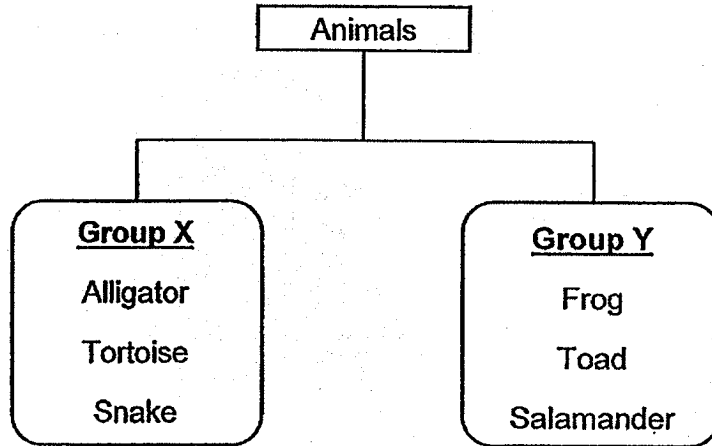

(a) State one similarity and one difference between the characteristics of the animals in the two groups above.

Similarity: _____ [1]

Difference: _____ [1]

(b) Study animal H below carefully.

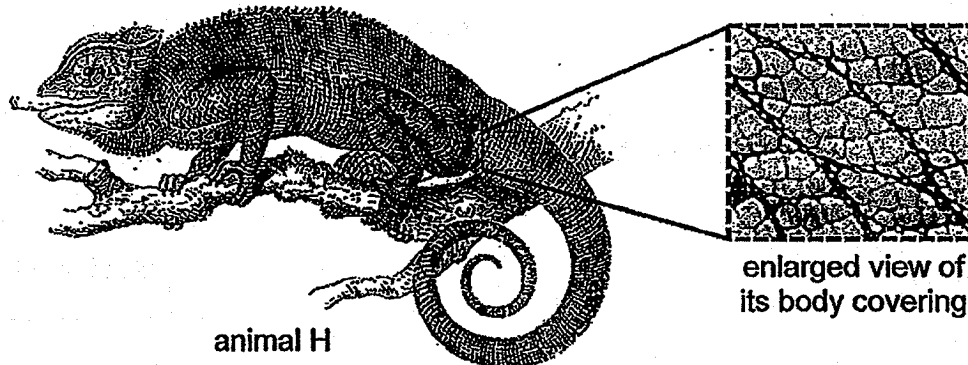

Which group X or Y should animal H be placed under? Give a reason for your answer. [1]

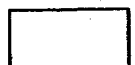

30. Zhi Hui wanted to find out if germinating seeds produced heat. He soaked some seeds in water before placing them in a glass container as shown.

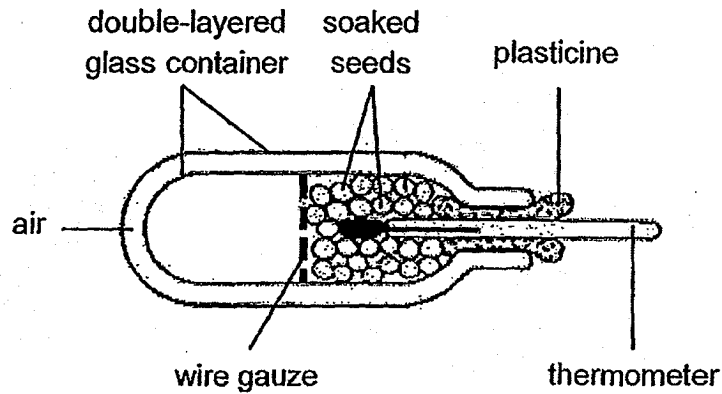

He measured the temperature in the container from time to time until all the seeds had germinated.

- (a) Give a reason why Zhi Hui did not fill the container completely with seeds. [1]

- (b) Explain how using a double-layered glass container with air in between helps to make the results of the experiment more reliable. [1]

- (c) As the seeds were germinating, the temperature in the glass container increased. What can Zhi Hui conclude from this observation? [1]



31. The diagram below shows an animal cell and a plant cell.

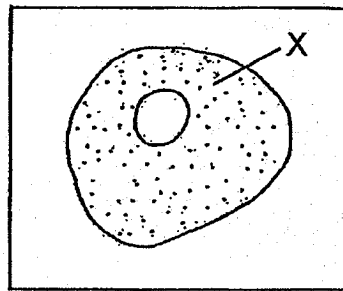

cell A

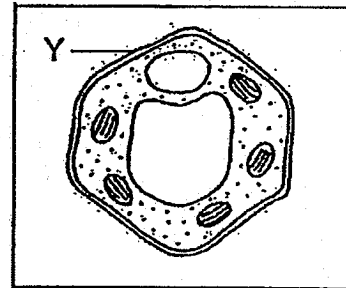

cell B

- (a) Identify which cell is a plant cell and which is an animal cell. [1]

Cell A: _____

Cell B: _____

- (b) State the function of part X of cell A. [1]

- (c) What will happen to the cell if part Y of cell B is removed? Explain your answer. [1]

32. Diagram 1 below shows the movement of substances in a plant.

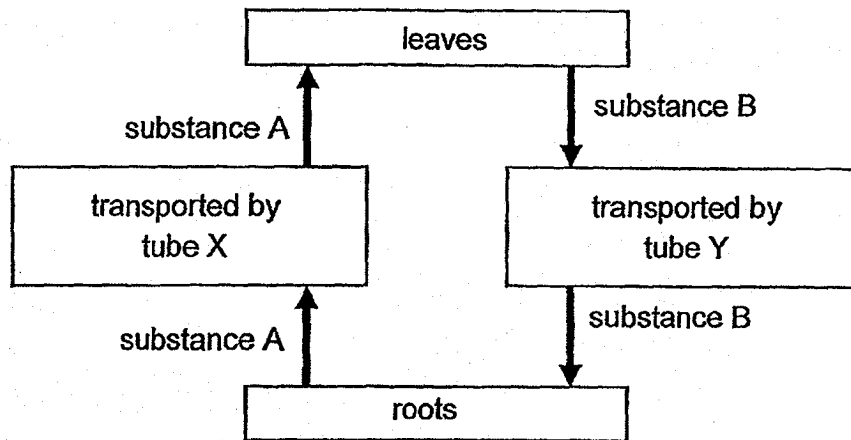

diagram 1

(a) (i) Identify tubes X and Y.

[1]

Tube X: _____

Tube Y: _____

(ii) Identify the substances A and B.

[1]

Substance A: _____

Substance B: _____

Diagram 2 below shows the circulatory system of organism K.

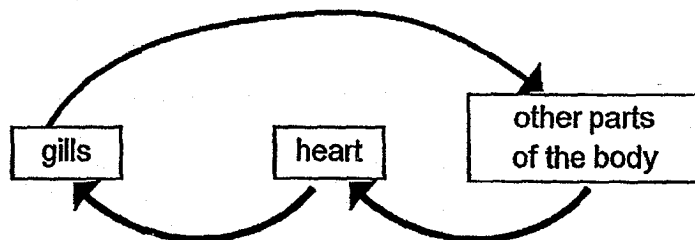
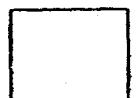
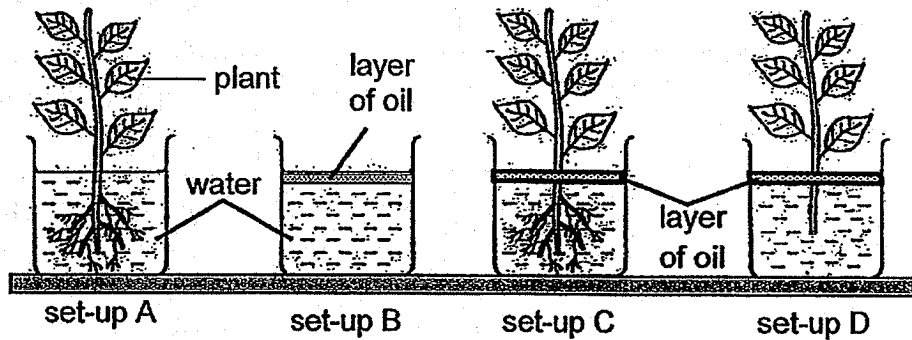

diagram 2

(b) Comparing diagrams 1 and 2, state one difference between the direction of transport system of the plant and the circulatory system of organism K. [1]



33. Laura conducted an experiment in a classroom as shown below. She wanted to find out if roots take in water.



- (a) Which pair of set-ups should she use to make a fair comparison? Explain your answer. [1]

Laura wanted to conduct another experiment to find out if the number of leaves affect the amount of water absorbed by the roots. She decided to use set-ups A and C to conduct the experiment.

- (b) Suggest two changes that Laura should do to set-up A and C to make the experiment a fair test. [2]

(i) _____

(ii) _____

- (c) What is the purpose of the layer of oil in this experiment? [1]

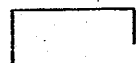

34. Wei Ling carried out an experiment on four sheets W, X, Y and Z each made of a different material. She placed sheet W on the side of a table and placed a heavy rock on it to hold it down firmly. Then she pressed the sheet down slowly until it broke. She repeated the experiment using sheets X, Y and Z.

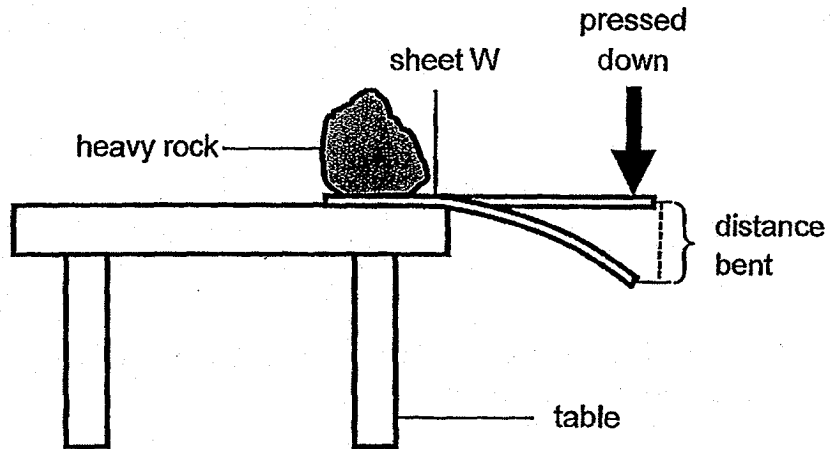

She recorded the results in the table below.

| Sheet | Greatest distance bent before breaking (cm) |
|-------|---|
| W | 7 |
| X | 1 |
| Y | 5 |
| Z | 2 |

- (a) State the property of material that Wei Ling was testing. [1]
-
- (b) Based on the results of the experiment, which one of the materials W, X, Y or Z should Wei Ling use to make a pair of chopsticks? Give a reason for your answer. [1]
-
-



35. Kim gently lowered an iron ball into a beaker of water as shown in the diagram below.

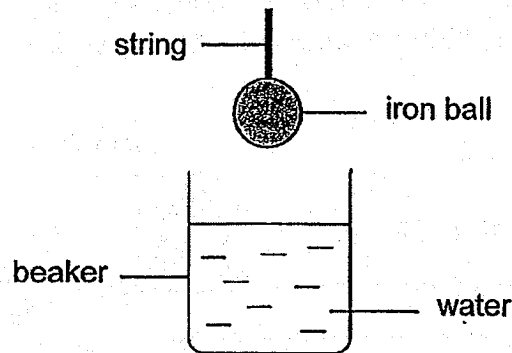

- (a) What change to the water level will Kim observe when the iron ball is fully lowered into the beaker of water? [1]

Kim then replaced the iron ball with a lighter glass ball of the same size and repeated the experiment.

- (b) Will the water level be lower, higher or remain the same as in her previous experiment? Explain your answer. [2]

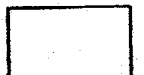

36. Study the set-up below.

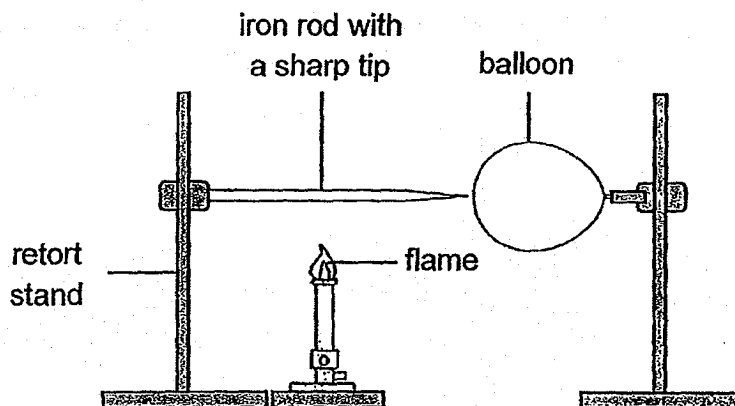

- (a) The iron rod was heated for 5 minutes and the balloon burst. Explain why the balloon burst. [1]

- (b) The iron rod was changed to a ceramic rod and the experiment was repeated. After 5 minutes, the balloon did not burst. Explain why. [2]

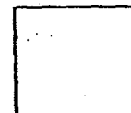

37. Ken conducted an experiment using two identical pots as shown below. Pot Y has a black surface while pot X has a white surface. Both pots were filled with 200 cm³ of water at 0 °C and heated with 2 similar burners.

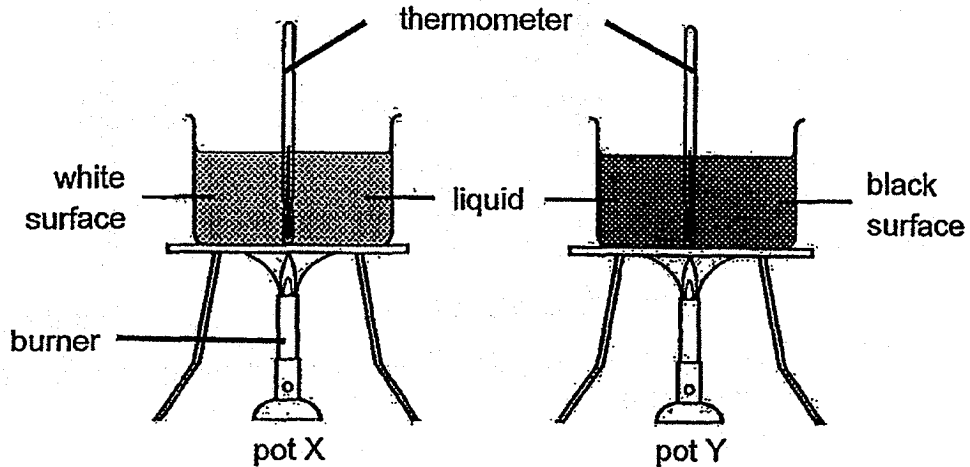

The temperatures of water in both pots X and Y were recorded every minute for some time. The graph below shows the results of Ken's experiment.

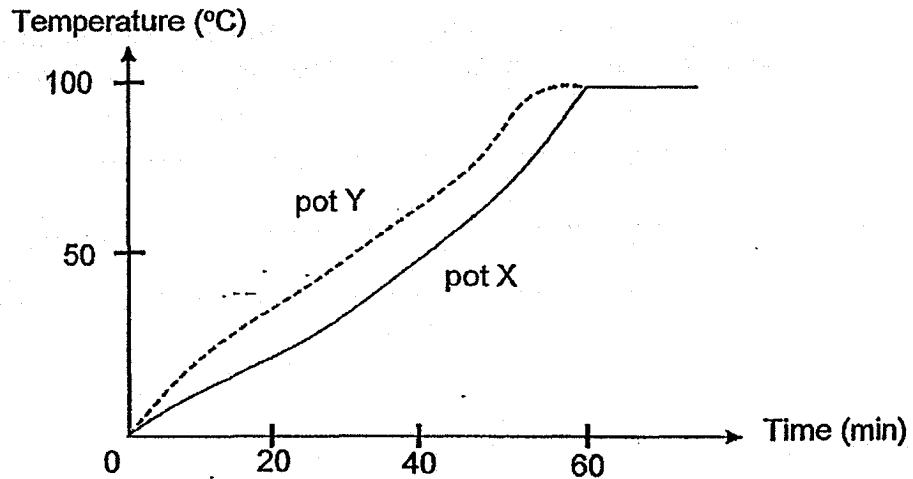

- (a) Based on the results above, which pot X or Y can be used to cook soup in a shorter time? Explain your choice. [2]

- (b) What will the temperature of the water be in both pots at the 65th minute? [1]

The diagram below shows a dog house that is in the garden.

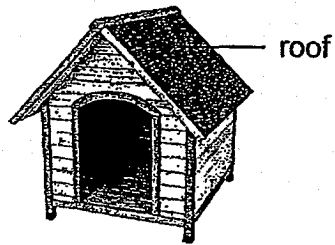

- (c) Based on the results of Ken's experiment, should Ken paint the roof of the dog house black or white if he wants to keep his dog cooler on a sunny day? Explain your answer. [2]



38. Rina wanted to find out which material is the most suitable for making a bottle to store essential oils. Essential oils, usually used for scenting rooms, are best stored away from direct light to prevent a loss of quality.

She placed material E at position X and shone the torch on it as shown below. A light sensor attached to a data logger was used to record the amount of light that passed through the material.

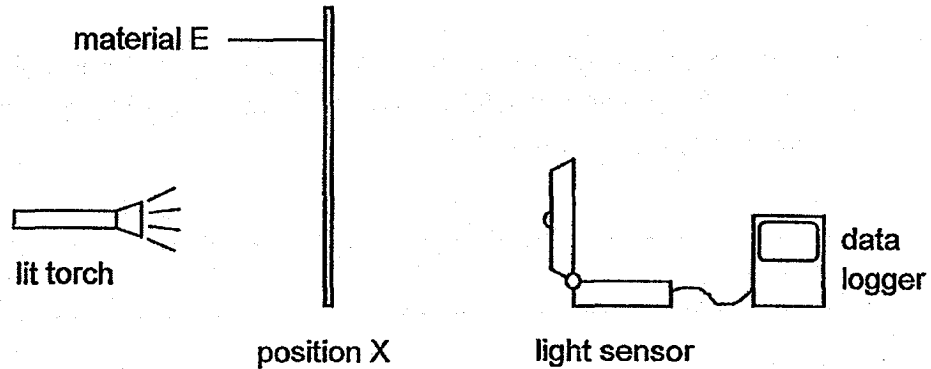

She repeated the experiment with materials F, G and H. For each material, she conducted the experiment three times and recorded the results in the table below.

| Material | Thickness (cm) | Average amount of light detected (units) |
|----------|----------------|--|
| E | 1 | 52 |
| F | 1 | 43 |
| G | 1 | 38 |
| H | 1 | 15 |

- (a) Give a reason why Rina repeated the experiment three times on each type of material. [1]

- (b) State the changed variable in this experiment. [1]

- (c) Based on the results in the table, which material E, F, G or H is most suitable for making bottles used for storing essential oils? Give a reason for your answer. [1]

Rina conducted a similar experiment using different thickness of material K.

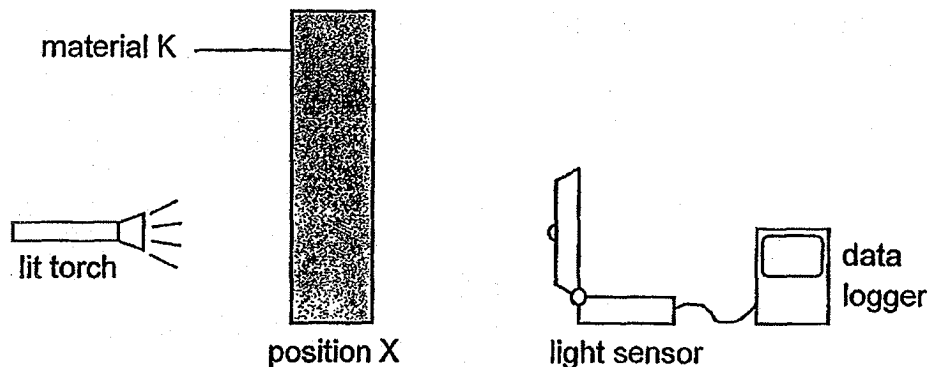

She recorded the results in the table below.

| Thickness (cm) | Average amount of light detected (units) |
|----------------|--|
| 5 | 42 |
| 6 | 32 |
| 7 | 25 |
| 8 | 8 |

(d) Write down a suitable aim for the experiment. [1]

(e) What can she conclude from the experiment? [1]



39. Tom conducted an experiment as shown below.

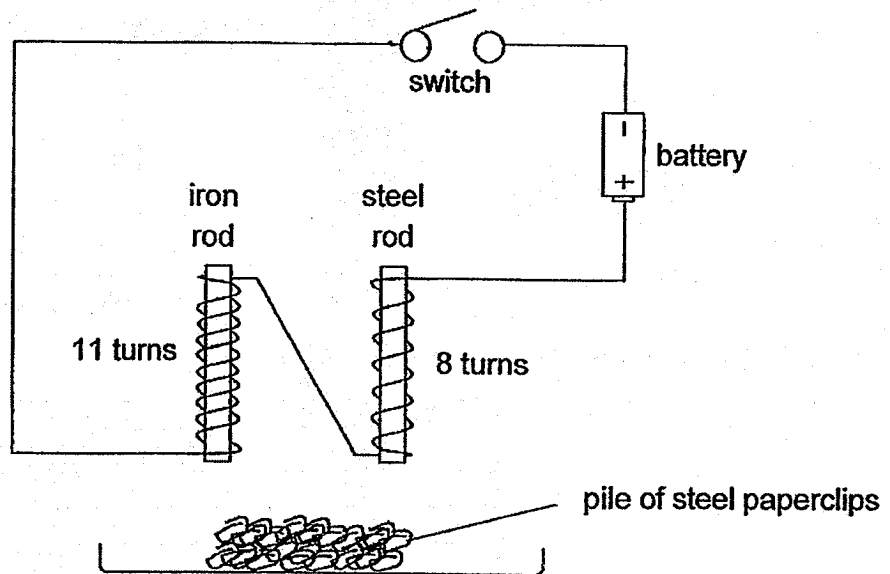

The two rods were placed 5 cm above a pile of steel paperclips before the switch was closed. The number of paperclips attracted to each rod are shown below.

| | Iron Rod | Steel Rod |
|-----------------------|----------|-----------|
| 1 st Trial | 15 | 10 |
| 2 nd Trial | 14 | 8 |
| 3 rd Trial | 16 | 9 |

(a) Tom's friend said that the experiment was not fair and they were not able to conclude which rod, iron or steel, was an electromagnet with a greater magnetic strength. Explain why Tom's friend is right. [2]

(b) List one change Tom can make to the set-up such that he can conclude which rod is an electromagnet with a greater magnetic strength. [1]

(c) What would be observed if two more batteries are connected in series to the circuit above? [1]



40. Study the circuits below. In the given circuits, all the bulbs were lit.

circuit X

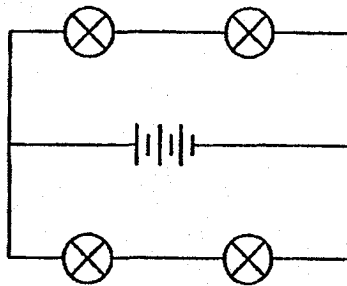

circuit Y

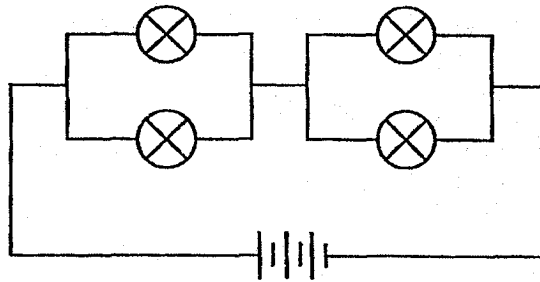

In the table below, write down the number of bulbs that would remain lit when one of the bulbs in each circuit is blown. [2]

| | Circuit X | Circuit Y |
|-------------------------------|-----------|-----------|
| Number of bulbs remaining lit | | |



41. Study the two graphs below. Graph 1 shows the average electricity bill for John's family. Graph 2 shows the average monthly temperature in Singapore.

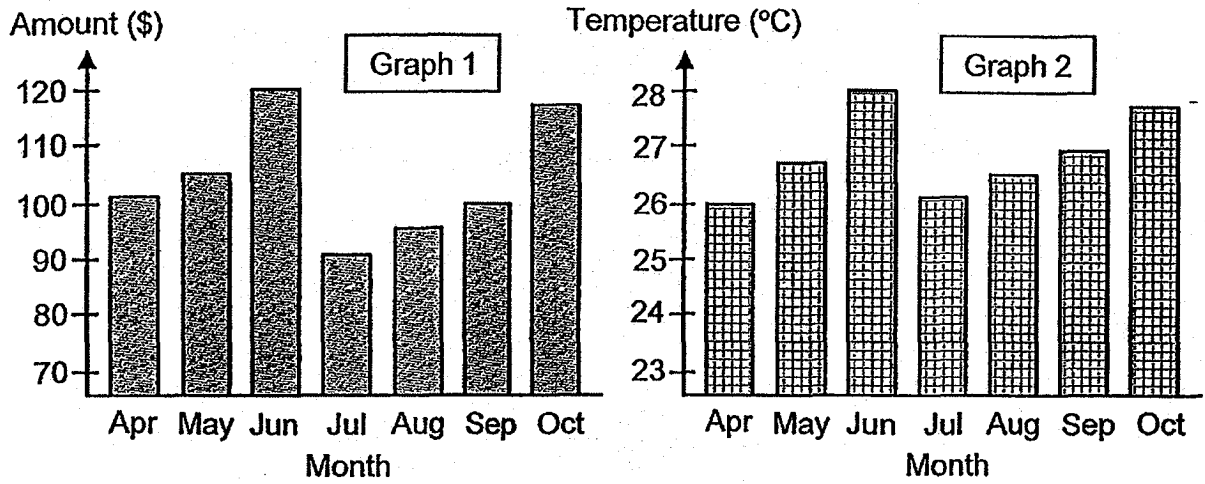

(a) John observed that there was a large increase in his electricity bill for the months of June and October. Based on the graphs, give a possible explanation for this increase. [2]

The following situation was observed at an electrical socket in John's house.

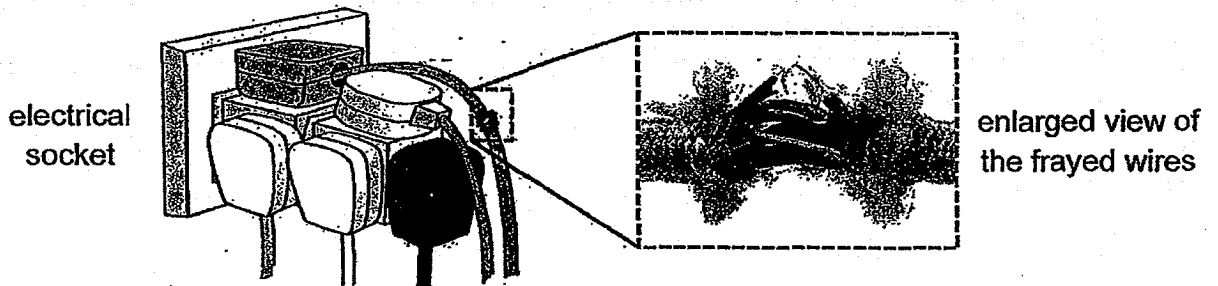

(b) Based on the above diagram, state two electrical safety issues and give a possible precaution John can take to address each issue. [2]

| | Safety Issue | Possible Precaution(s) to be taken |
|------|--------------|------------------------------------|
| (i) | | |
| (ii) | | |

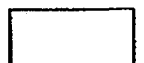

**CHIJ ST NICHOLAS GIRLS' SCHOOL (PRIMARY SECTION)
2018 P5 SA1 SCIENCE | CORRECTIONS SHEET
BOOKLET B (OPEN-ENDED QUESTIONS)**

NAME: _____ () CLASS: P5 _____ DATE: _____

INSTRUCTIONS: Please fill in this sheet using **GREEN INK** only.

| QN. NO. | CORRECTION(S) |
|---------|---------------|
| 29 | Similarity: |
| | Difference: |
| 30 | (a) |
| | (b) |
| | (c) |
| 31 | Cell A: |
| | Cell B: |
| 32 | Tube X: |
| | Tube Y: |
| | Substance A: |
| 33 | Substance B: |
| | (a) |
| (b) | |

| QN. NO. | CORRECTION(S) |
|---------|---------------|
| (c) | |
| 34 | (a) |
| | (b) |
| 35 | (a) |
| | (b) |
| 36 | (a) |
| | (b) |
| 37 | (a) |
| | (b) |
| | (c) |
| 38 | (a) |
| | (b) |
| | (c) |
| 39 | (d) |
| | (e) |
| | (a) |
| (b) | |
| (c) | |

| CIR. NO. | CORRECTION(S) | |
|--------------|-------------------------------|------------------------------------|
| | Circuit X | Circuit Y |
| 40 | Number of bulbs remaining lit | |
| 41 | (a) | |
| | (b) | |
| | Safety Issue | Possible Precaution(s) to be taken |
| | (1) | |
| | (11) | |
| END OF PAPER | | |

SCHOOL : CHIJ PRIMARY SCHOOL
 LEVEL : PRIMARY 5
 SUBJECT : SCIENCE
 TERM : 2018 SA1

SECTION A

| | | | | | | | | | |
|------|-----|-----|-----|-----|-----|-----|-----|-----|-----|
| Q 1 | Q2 | Q3 | Q4 | Q5 | Q6 | Q7 | Q8 | Q9 | Q10 |
| 2 | 2 | 2 | 2 | 2 | 2 | 3 | 4 | 4 | 3 |
| Q 11 | Q12 | Q13 | Q14 | Q15 | Q16 | Q17 | Q18 | Q19 | Q20 |
| 4 | 1 | 3 | 1 | 1 | 1 | 4 | 2 | 1 | 1 |
| Q 21 | Q22 | Q23 | Q24 | Q25 | Q26 | Q27 | Q28 | | |
| 1 | 3 | 2 | 3 | 3 | 4 | 2 | 4 | | |

SECTION B

| | |
|------|---|
| Q29) | <p>a)Similarity : They both reproduce by laying eggs. Difference: Y can breathe in water but X cannot breathe in water.</p> <p>b)X. All animals in X have scaly skin as a body covering like H but Y has moist skin as their body covering .</p> |
| Q30) | <p>a)So that there is space for air in the glass container for the seeds to germinate.</p> <p>b)Air is a poor conductor of heat and will not allow heat to enter or be lost . As his aim is to find out if germinating seeds produced heat, the heat the thermometer senses is only from the seeds.</p> <p>c)Germinating seeds produces heat.</p> |
| Q31) | <p>a)Cell A : Animal cell Cell B : Plant cell</p> <p>b)It allows substance to move within the cell</p> <p>c)The cell will not have a regular shape. Part Y is the cell wall and cell wall are structures that gives the cell its regular shape.</p> |

| | |
|------|--|
| Q32) | <p>a)i)Tube X : Xylem tube Tube Y : Phloem tube</p> <p>a)ii)Substance A : Water Substance B : Food</p> <p>b)Plant transport system flows in one direction but the circulatory system of K flows in a circular direction.</p> |
| Q33) | <p>a)C and D. All other variables are kept constant except only the changed variable which is the presence of roots.</p> <p>b)i)A should have a larger of oil over the water. ii)There should be lesser leaves in one set-up and more leaves in the other.</p> <p>c)To ensure that the amount of water lost in the beaker is due to the presence of leaves and not due to water evaporation.</p> |
| Q34) | <p>a)The material's flexibility.</p> <p>b)X as it bends the least distant before breaking so that it will be firm to pick up the food.</p> |
| Q35) | <p>a)The water level will be higher.</p> <p>b)Remain the same. Both balls have the same size so they have the same volume and therefore the water level will remain the same.</p> |
| Q36) | <p>a)The iron rod gained heat form the flame and expanded until the tip of the rod reached the balloon and popped it.</p> <p>b)The ceramic rod did not gain as much heat and did not expand as much as the iron rod, as ceramic is not a good conductor of heat as compared to the iron rod.</p> |
| Q37) | <p>a)Y. The temperature of water increased faster to 100c than that of X. This shows that water in Y gained heat from the burner faster than in X thus is will be able to cook the soup in a shorter time.</p> <p>b)100°C.</p> <p>c)White. The pot with a black surface gained heat faster than the pot with the white surface. If he wants to keep his dog cool, a white painted roof will not gain heat as fast as a black painted roof.</p> |
| Q38) | <p>a)So that the results are more reliable as sometime there are different out comes.</p> |

| | |
|------|---|
| | <p>b)The type of material</p> <p>c)H as it allowed the least amount of light to pass through which makes the essential oil not have a loss of quality as it is not under direct light.</p> <p>c)To find out if the thickness of a material affects the amount of light that can pass through it.</p> <p>d)The thicker the object, the lesser the amount of light that can pass through.</p> |
| Q39) | <p>a)There was another changed variable which was the amount of turns of coils around each rod. The more the number of turns of coils around an electromagnet, the stronger it is therefore Tom's friends was right.</p> <p>b)Have the same amount of turns of coils around each rod.</p> <p>c)There would be more paper clips attracted by each of the rods.</p> |
| Q40) | 2 / 3 |
| Q41) | <p>a)As it is warmer in June and October, John's family would have turned on the fan or air-conditioner for a longer period of time which uses more electricity therefore his electricity bill increases.</p> <p>b)i)Too many plugs in one socket -->Limit one socket to a maximum of two or three plugs.</p> <p>ii)Exposed wires -->Not to use this plug any more or get an electrician to fix it.</p> |

