



HENRY PARK PRIMARY SCHOOL
2014 SEMESTRAL EXAMINATION 1
PRIMARY 6 SCIENCE

Booklet A

Name: _____ ()

Class: Primary 6 _____

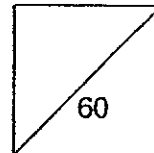

30 Questions
60 Marks

Total Time for Booklet A and B: 1 h 45 min

DO NOT OPEN THIS BOOKLET UNTIL YOU ARE TOLD TO DO SO.

READ AND FOLLOW INSTRUCTIONS CAREFULLY.

Booklet A (60 marks)

For each question from 1 to 30, four options are given. One of them is the correct answer. Make your choice (1, 2, 3 or 4). Shade the correct oval (1, 2, 3 or 4) on the **Optical Answer Sheet**.

1. Alex made some observations of Animal F and wrote them in his Science journal.

Animal F
• Has hair on its body
• Can fly

Which of the following animal groups does Animal F belong to?

- (1) Fish
- (2) Birds
- (3) Insects
- (4) Mammals

()

2. Siti conducted an experiment with a flower shown below.

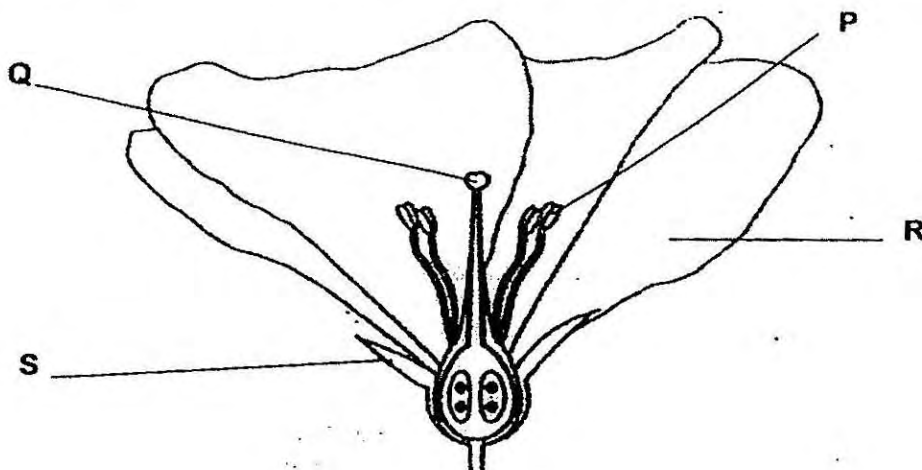

She removed one part of the flower. The flower did not produce any seeds after that.

Which part of the flower, P, Q, R or S did Siti remove?

- (1) P
- (2) Q
- (3) R
- (4) S

()



3. Ali had to classify the four plants, A, B, C and D, shown below.

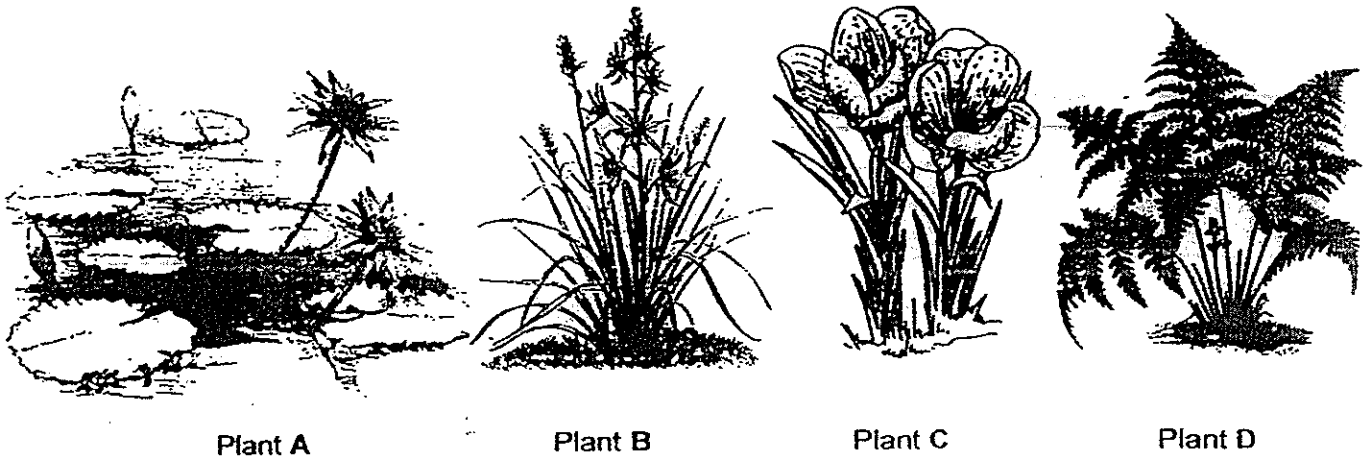

He classified them using the chart below.

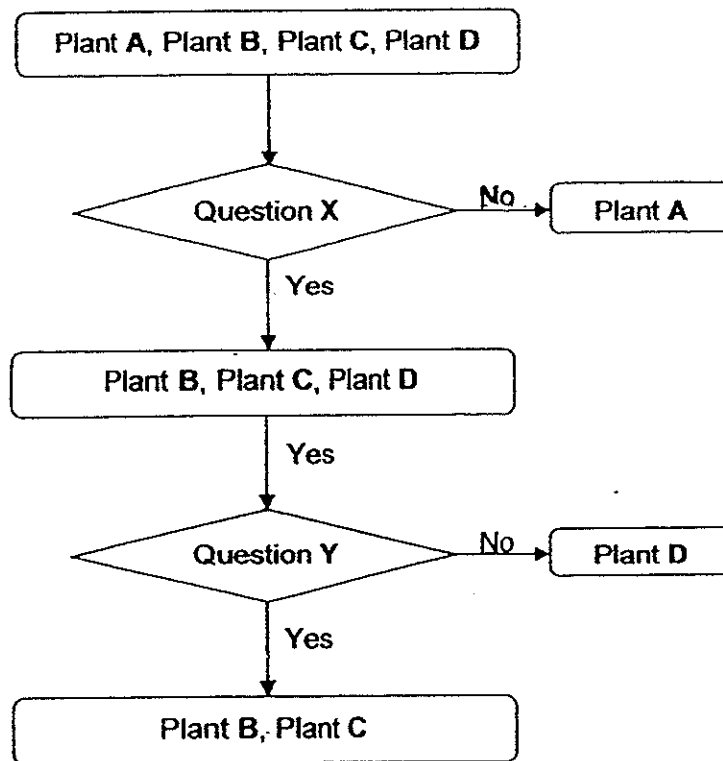

What were the two questions, X and Y?

	Question X	Question Y
(1)	Does it grow on water?	Does it reproduce from seeds?
(2)	Does it grow on land?	Does it reproduce from seeds?
(3)	Does it grow on water?	Does it reproduce from spores?
(4)	Does it grow on land?	Does it reproduce from spores?

()



4. Which one of the following shows the correct order of processes in the life cycle of a flowering plant?

(1)

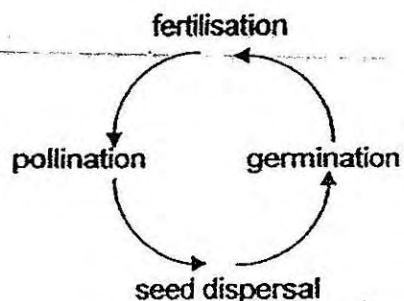

(2)

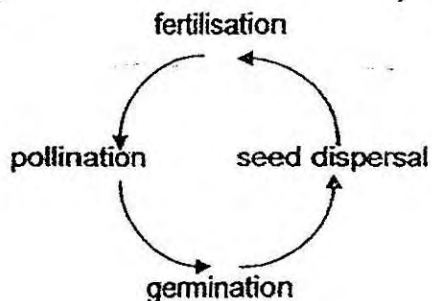

(3)

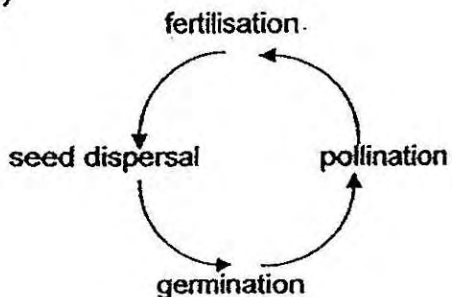

(4)

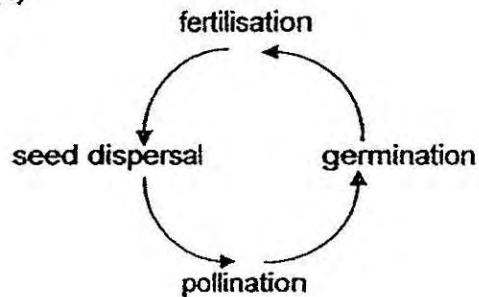

()

5. Sarah conducted an experiment with substances X, Y and Z. These are her observations.

X cannot be compressed.
 Y will take the shape of the container.
 Z can be compressed.

Y becomes Z when it gains heat.
 X becomes Y when it gains heat.

Based on her observations, identify X, Y and Z respectively.

	X	Y	Z
(1)	Solid	Liquid	Gas
(2)	Solid	Gas	Liquid
(3)	Liquid	Solid	Gas
(4)	Gas	Liquid	Solid

()



6. The diagram below shows how water changes from one state to another.

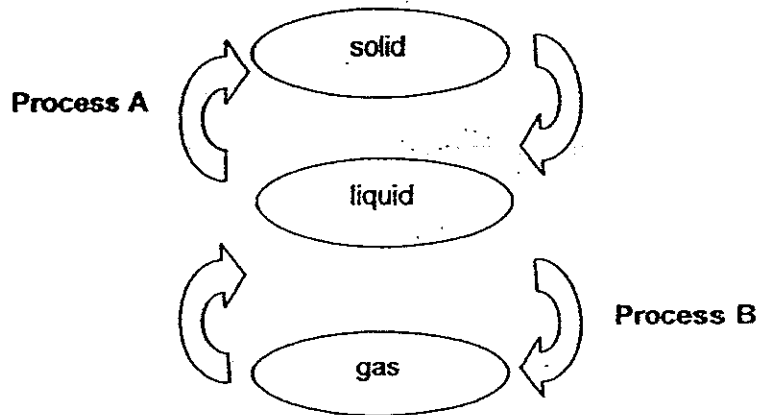

Which of the following is true about Process A and Process B?

	Process A		Process B	
(1)	Freezing	Heat gain	Evaporation	Heat loss
(2)	Freezing	Heat loss	Evaporation	Heat gain
(3)	Boiling	Heat gain	Condensation	Heat gain
(4)	Boiling	Heat loss	Condensation	Heat loss

()

7. The table below shows the boiling and freezing points of four substances, W, X, Y and Z.

Substance	Boiling Point (°C)	Freezing Point (°C)
W	50	20
X	120	40
Y	200	130
Z	90	3

Which of the following substances will be a liquid at 65°C?

- (1) W and X only
 - (2) W and Y only
 - (3) X and Z only
 - (4) Y and Z only
- ()

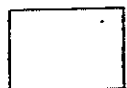

8. The diagram below shows four different parts of the balsam plant.

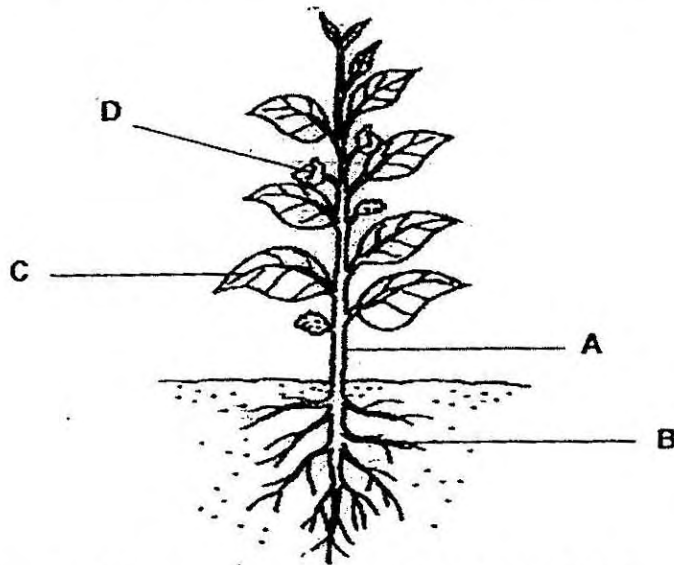

The main function of part _____ of the plant is reproduction.

- (1) A
- (2) B
- (3) C
- (4) D

()

9. The diagram below shows the human digestive system.

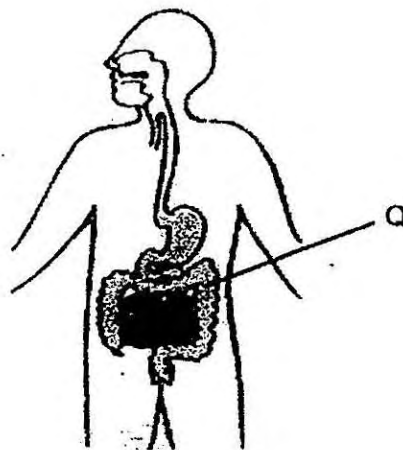

What is the function of part Q?

- (1) It removes water from the undigested food.
- (2) It breaks food down into simple substances.
- (3) It passes the undigested food out of the body.
- (4) It absorbs the digested food into the bloodstream.

()

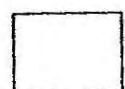

10. The diagram below shows the direction of blood flow indicated by arrows, A, B, C and D, in the human circulatory system.

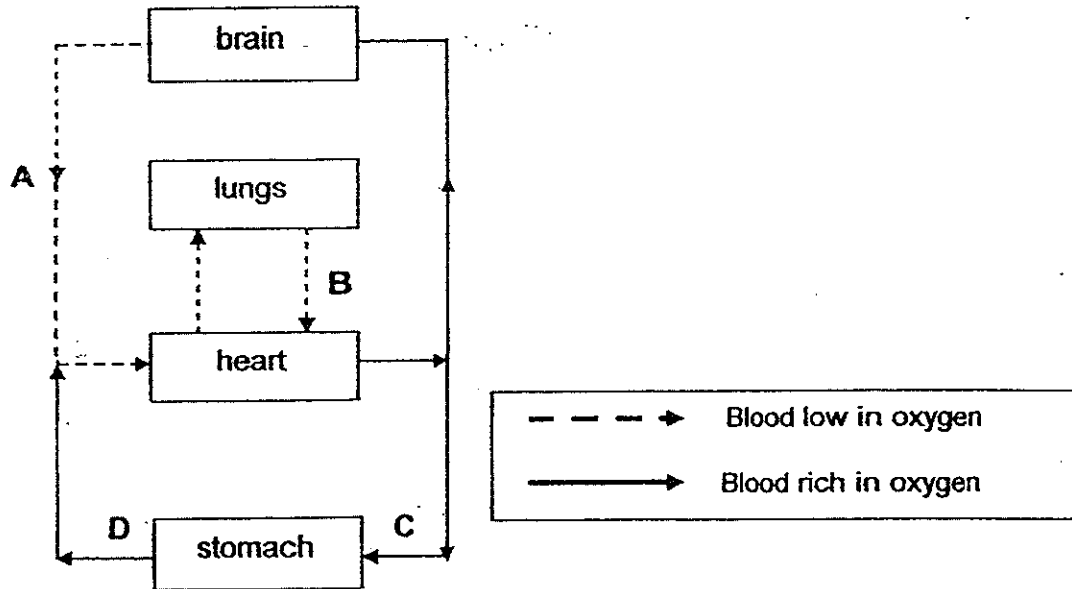

Which two arrows were not drawn correctly?

- (1) A and B
- (2) B and D
- (3) B and C
- (4) C and D

()

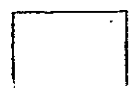

11. Ali had three rods, P, Q and R, made of different materials. He placed them in various positions, X, Y and Z, in the circuit below.

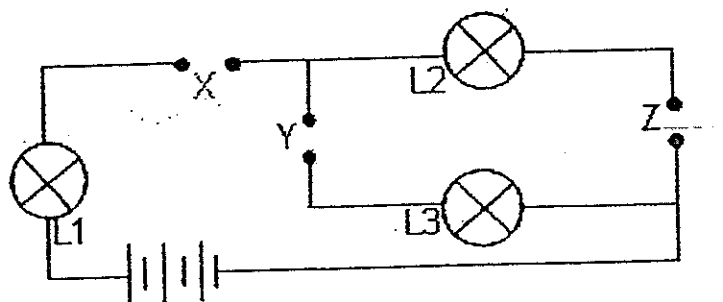

The results of the experiment are shown in the table below.

Positions where rods were placed			Did the bulb light up?		
X	Y	Z	L1	L2	L3
P	Q	R	Yes	Yes	No
Q	R	P	No	No	No
R	P	Q	Yes	No	Yes

Which one of the inferences can he make based on the results above?

- (1) Only rod R is a non-conductor of electricity.
- (2) Only rods P and R are conductors of electricity.
- (3) Only rods P and Q are conductors of electricity.
- (4) Rods Q and R are better conductors of electricity than rod P.

()

12. Which of the following does **not** show effects of heat gain?

- (1) Water freezing
- (2) Ice cube melting
- (3) Drying clothes in the garden
- (4) Cooking rice in a rice cooker

()



13. In an experiment, Jamal uses an electrical hot plate to heat four containers of water, S, T, U and V, to 100°C.

The amount and temperature of water in each container is the same at the start of the experiment. The material of each container is different.

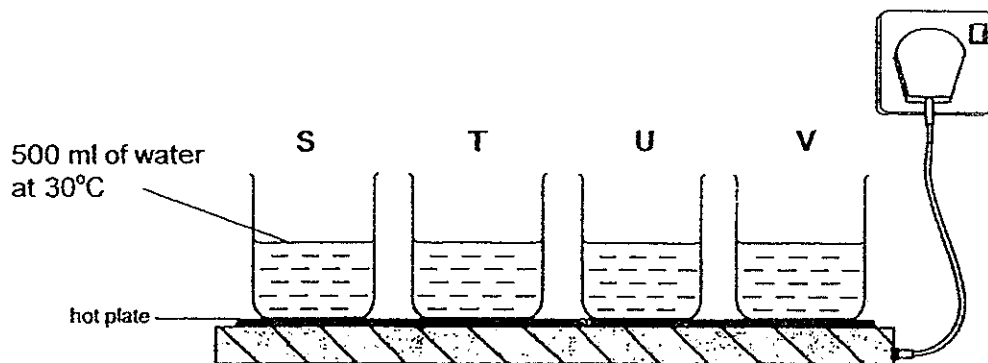

He then recorded how long it took for each container to reach 100°C in the table below.

Container	Time taken to reach 100°C (minutes)
S	20
T	50
U	15
V	35

Based on his results above, arrange the containers from the poorest conductor to the best conductor of heat.

- (1) T, V, S, U
- (2) T, S, V, U
- (3) U, S, V, T
- (4) U, V, S, T

()

14. Many of our daily activities use energy from burning fossil fuels such as coal and oil.

We need to conserve such energy resources because fossil fuels

- A: are renewable.
- B: take millions of years to form.
- C: are not used up and the environment stays clean.

- (1) B only
- (2) C only
- (3) A and B only
- (4) A and C only

()



15. Dheeva made a toy with rubber bands, a Y-shaped stick and a marble as shown in the diagram below.

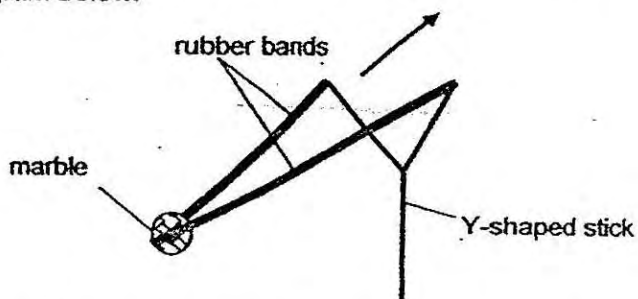

Dheeva released the marble and it landed at a distance.

If he wanted the marble to travel a longer distance when released, which of the following would Dheeva carry out?

- A: Use more rubber bands
- B: Stretch the rubber bands further.
- C: Use a marble with a greater mass.
- D: Change the colour of the rubber band.

- (1) A and B only
- (2) A and C only
- (3) B and D only
- (4) A, B and C only

()

16. Bob kicks a football.
The path taken by the football after he has kicked it is shown below.

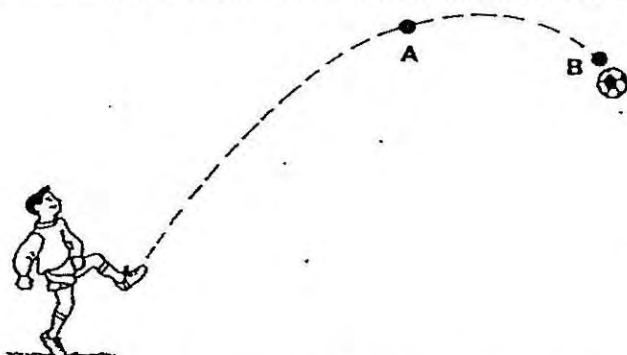

Which of the following statements show correctly what happens to the amount of gravitational potential energy and kinetic energy of the football between points A and B?

	Gravitational Potential Energy	Kinetic Energy
(1)	Decreases then increases	Decreases then increases
(2)	Decreases then increases	Increases then decreases
(3)	Increases then decreases	Decreases then increases
(4)	Increases then decreases	Increases then decreases

()



17. Raja wanted to investigate how the amount of light affects the growth of plants. The diagram below shows each of his set-ups in a glass tank.

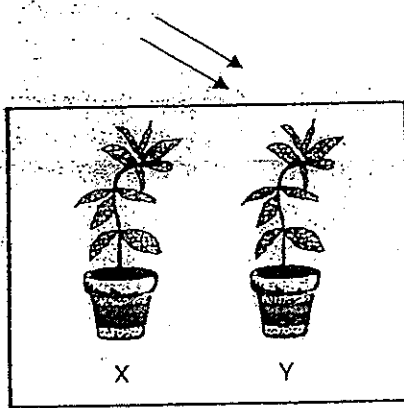

glass tank covered with tracing paper

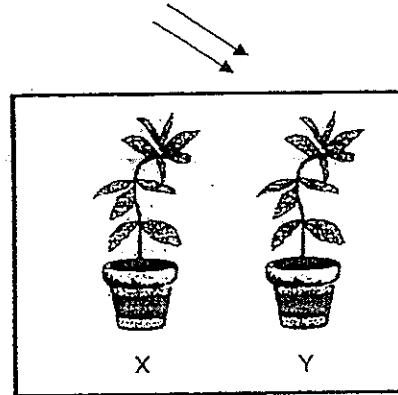

glass tank covered with black paper

Which one of the following could be used as a control for his experiment?

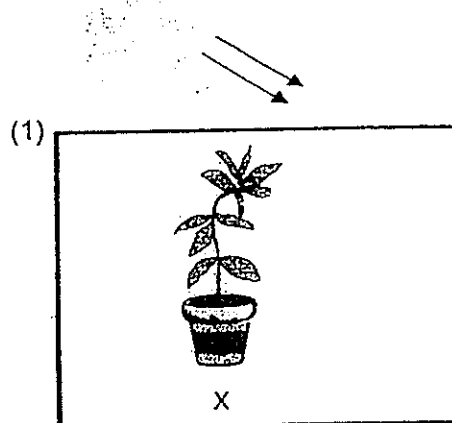

glass tank covered with tracing paper

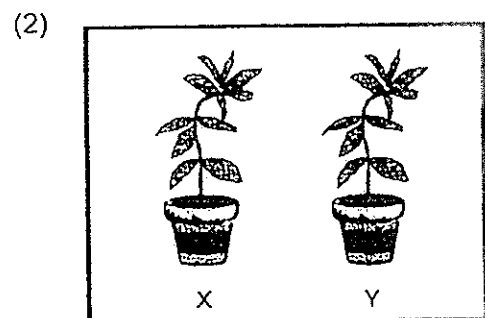

glass tank covered with dark paper

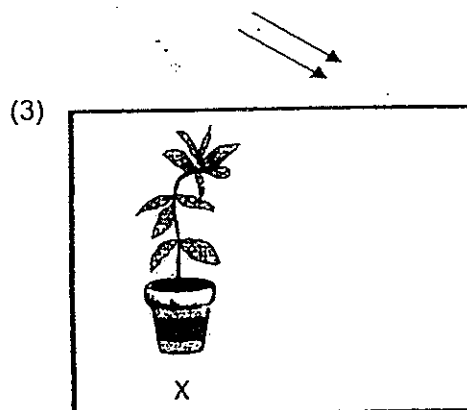

glass tank

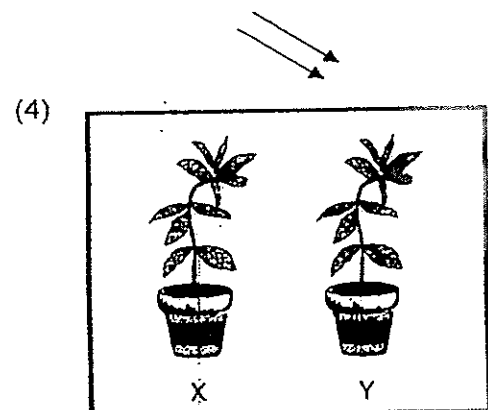

glass tank

()



18. Sue carried out an experiment with some water plants and fishes. She used 3 transparent jars, A, B and C, of the same size for her experiment. In each jar, she put in 10 fishes of the same type.

The table below shows the results of her experiment.

Jar	Size of jar	Amount of light (lux)	Number of water plants	Amount of water (ml)	Number of fishes alive at the end of the experiment
A	Medium	300	2	1500	3
B	Medium	300	8	1500	9
C	Medium	300	4	1500	6

What hypothesis is Sue testing?

- (1) The greater the size of the jar, the greater the chance of survival of the fishes.
- (2) The greater the amount of light, the greater the chance of survival of the fishes.
- (3) The greater the amount of water, the greater the chance of survival of the fishes.
- (4) The greater the number of water plants, the greater the chance of survival of the fishes.

()



19. The diagram below shows a loop apparatus and a ball bearing that is released from Point Y.

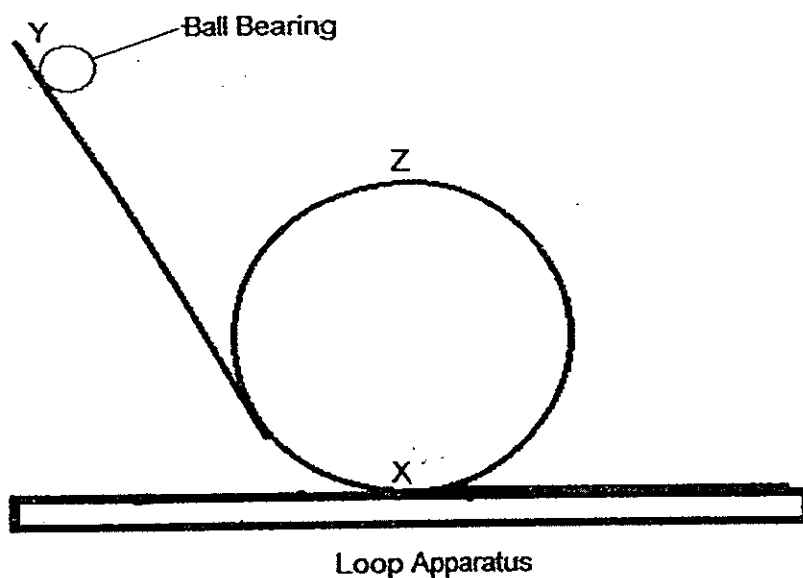

Which of the following statements are correct about the ball bearing at points, X, Y and Z?

- A: The ball bearing has the greatest kinetic energy at X.
- B: The ball bearing has the greatest kinetic energy at Y.
- C: The ball bearing has less gravitational potential energy at X than at Y.
- D: The ball bearing has less gravitational potential energy at Y than at Z.

- (1) A and C only
- (2) B and D only
- (3) A, C and D only
- (4) B, C and D only

()

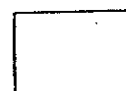

20. In an experiment, Moses put a bar magnet which has been divided into five equal parts, A, B, C, D and E, into a tray of iron filings as shown in the diagram below.

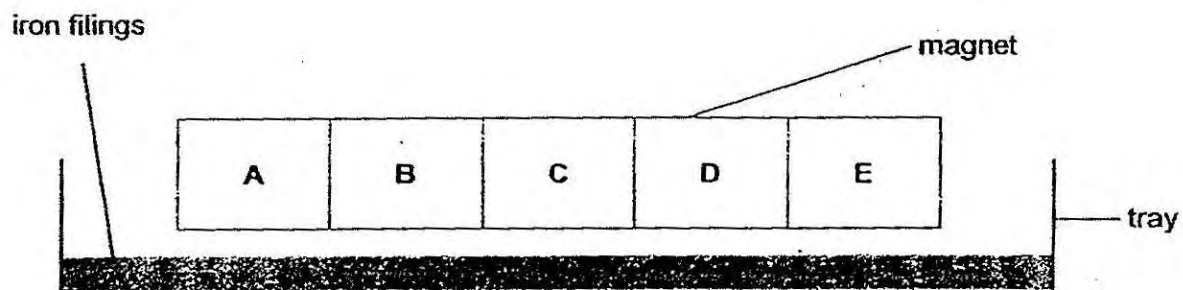

Then, he measured the mass of iron filings found attracted to each part of the bar magnet. He repeated the experiment another two times.

The table below shows the results of the experiment.

Experiment	Mass of iron filings (g)				
	A	B	C	D	E
1 st	10.2	7.1	2.2	7.4	10.5
2 nd	10.9	6.9	2.6	7.1	10.6
3 rd	10.3	7.5	3.0	7.3	10.6

Which of the following statements about the bar magnet are correct?

- A: There is no magnetic force in the middle part of the magnet.
- B: The magnetic strength of the poles of the magnet is the strongest.
- C: The magnetic strength of the middle part of the magnet is the weakest.
- D: The magnetic strength increases from one pole to the other pole of the magnet.

- (1) A and B only
- (2) B and C only
- (3) B and D only
- (4) C and D only

()



21. Fiona carried out an experiment to find out whether magnetism can pass through aluminium or steel.

In her experiment, she used aluminium and steel sheets of the same thickness. She also used identical magnets and iron nails.

The diagram below shows her experimental set-ups, A and B.

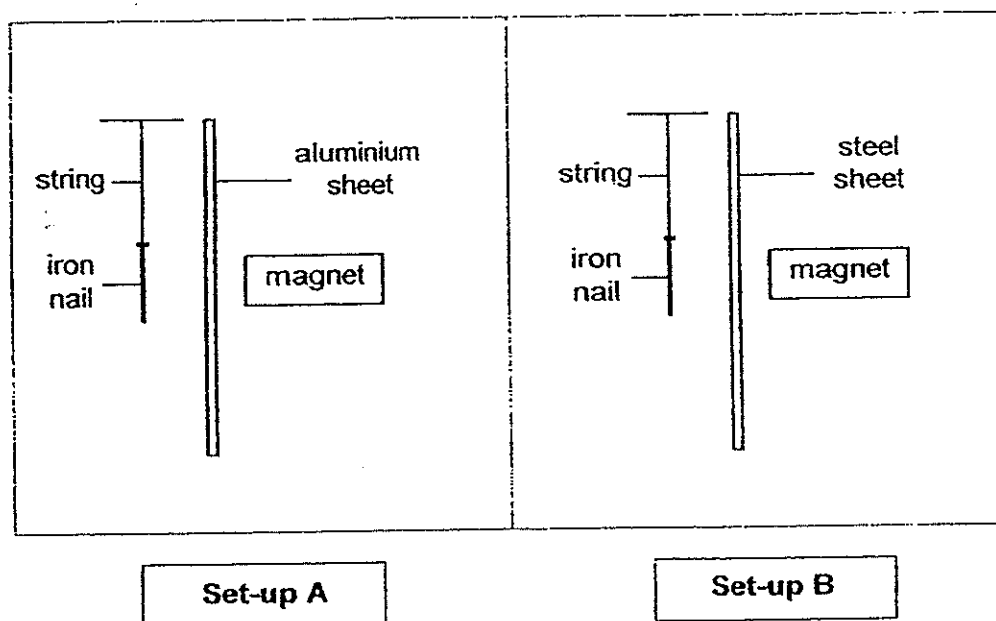

What would Fiona observe in set-ups A and B?

- (1) Both iron nails would remain stationary.
- (2) Both iron nails would move towards the magnets.
- (3) Only iron nail in set-up A would move towards the magnet.
- (4) Only iron nail in set-up B would move towards the magnet.

()



22. The experimental set-up shown below has a heavy iron ball hung from the ceiling with a slab of plasticine under it.

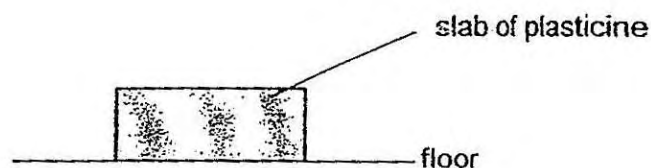
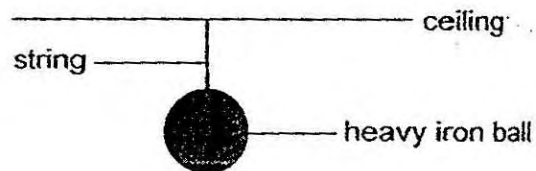

Which of the following is correct about the force involved and its effect when the string is cut with a pair of scissors?

	Force involved	Effect of the force
(1)	Friction	The slab of plasticine changes shape.
(2)	Weight	The slab of plasticine changes shape.
(3)	Friction	The slab of plasticine bounces up and down.
(4)	Gravity	The mass of the slab of plasticine decreases.

()



23. Chloe plays with a pogo stick as shown in the diagram below.

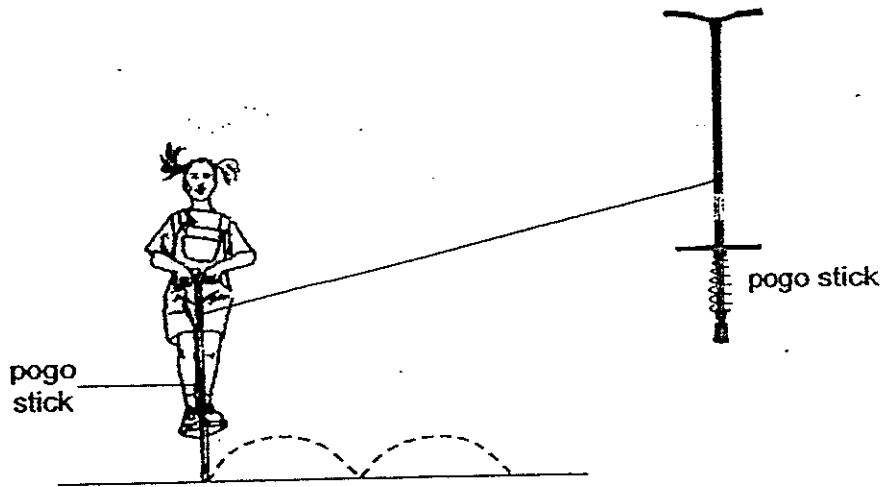

What are the forces involved when she jumps around on the pogo stick?

- A: Frictional force
- B: Magnetic force
- C: Gravitational force
- D: Elastic spring force

- (1) C and D only
- (2) A, B and D only
- (3) A, C and D only
- (4) B, C and D only

()

24. The diagram below shows the sole of a shoe.

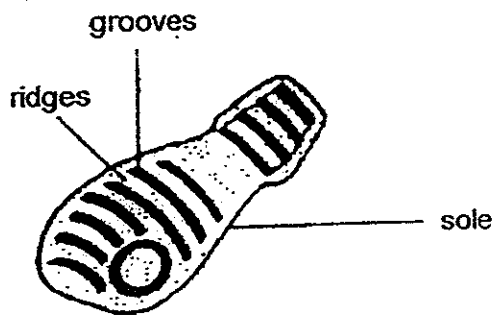

The sole is covered with grooves and ridges because _____

- (1) they help to increase friction
- (2) they form a beautiful pattern
- (3) they make the sole last longer
- (4) they help to cut down material used

()



25. An experiment was carried out for four objects, A, B, C and D, of different masses and a spring.

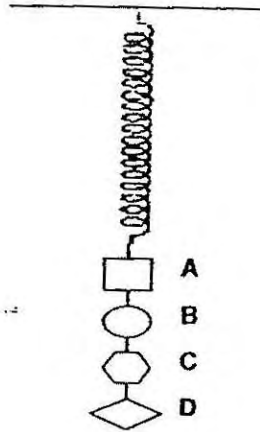

When each of the objects was hung on the spring, the length of the spring was measured.

The graph below shows the results of the experiment.

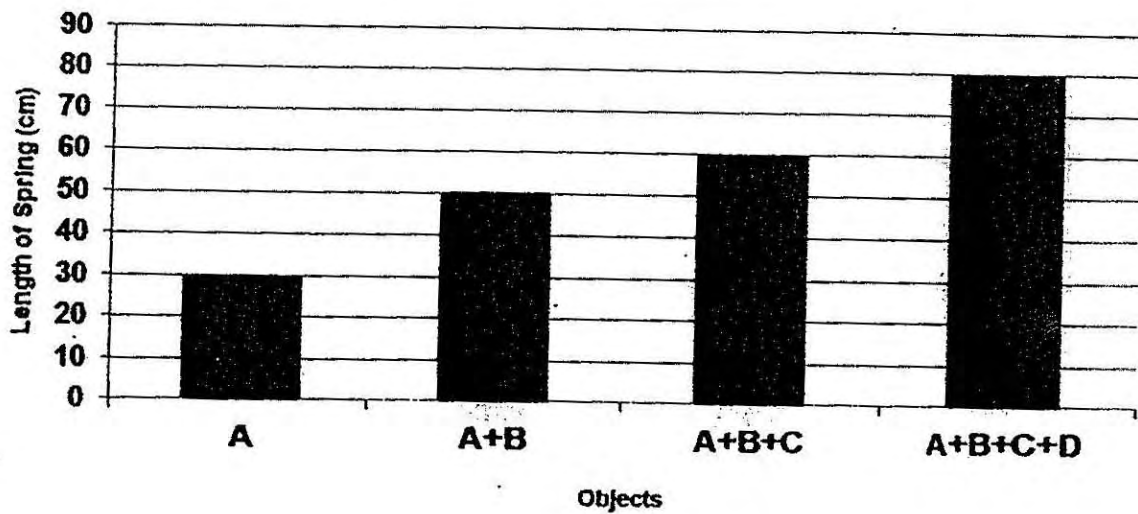

The original length of the spring is 18 cm.

Which one of the following objects causes the **shortest** extension in the spring?

- (1) A
- (2) B
- (3) C
- (4) D

()

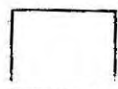

26. An iron nail becomes a temporary magnet when it is placed in a coil of wire joined to the batteries.

Jonathan wants to find out if the number of batteries affects the strength of a magnet. He sets up two arrangements. In each arrangement, he test the strength of the magnet by counting the number of steel paper clips it can attract.

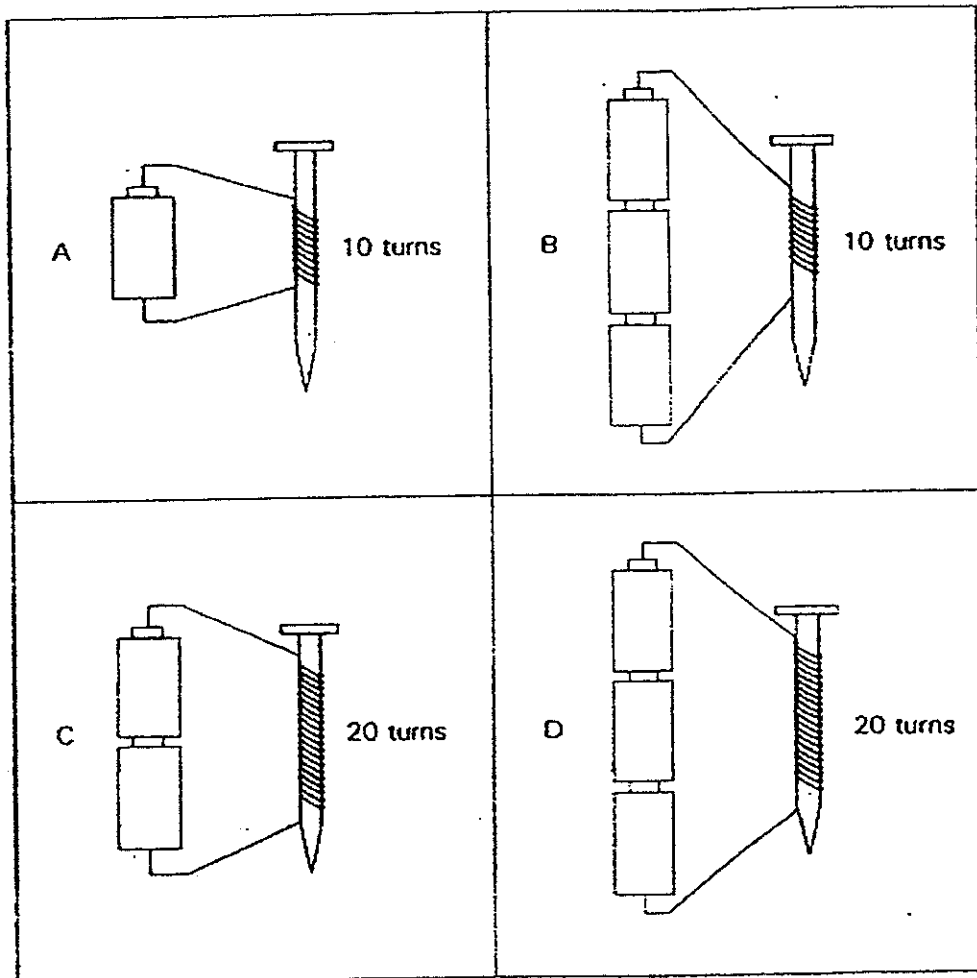

In order for Jonathan to conduct a fair test, which of the two arrangements as shown above should he use?

- (1) A and C.
- (2) B and C
- (3) B and D
- (4) C and D

()

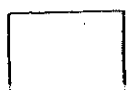

27. Which of the following effects are possible when a force is applied to an object?

- A: The mass of the object can change.
- B: The shape of the object can change.
- C: The speed of the object can change if it is moving.

- (1) A and B only
- (2) A and C only
- (3) B and C only
- (4) A, B and C

()

28. Fahrin has three rods labelled A, B and C.

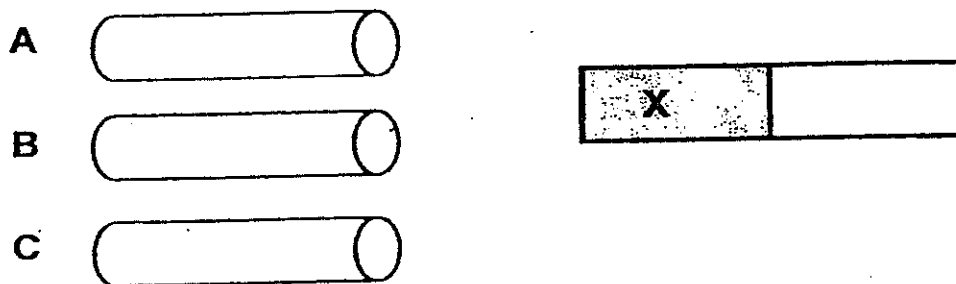

He carried out an experiment by bringing part X of a bar magnet near to each end of the three rods, A, B and C, as shown above.

He then recorded his results in the table below.

Rod	Observation
A	Both ends of Rod A are attracted to part X of the bar magnet.
B	One end of Rod B is attracted to part X of the bar magnet while the other end repels.
C	Both the ends of Rod C are not attracted to part X of the bar magnet.

Which of the following statements about rods A, B and C is likely to be correct?

- (1) Rod A is non-magnetic.
- (2) Rod B is a magnet.
- (3) Both Rod A and Rod B are magnets.
- (4) Both Rod A and Rod C are made of magnetic materials.

()



29. Phyllis wanted to investigate whether garden snails prefer dark or bright conditions. She used the following apparatus and materials for her investigation.

- some water
- some leaves
- some garden snails
- 2 similar containers

Which variables should Phyllis keep the same to ensure that her investigation was fair?

- A: The amount of leaves in each container.
 B: The amount of water sprinkled over the leaves.
 C: The number of garden snails in each container.
 D: The amount of light each container was exposed to.

- (1) A and C only
 (2) A, B and C only
 (3) A, B and D only
 (4) B, C and D only

()

30. The graph below shows the effect of temperature on the number of organisms, A, B, C and D, living at a particular habitat.

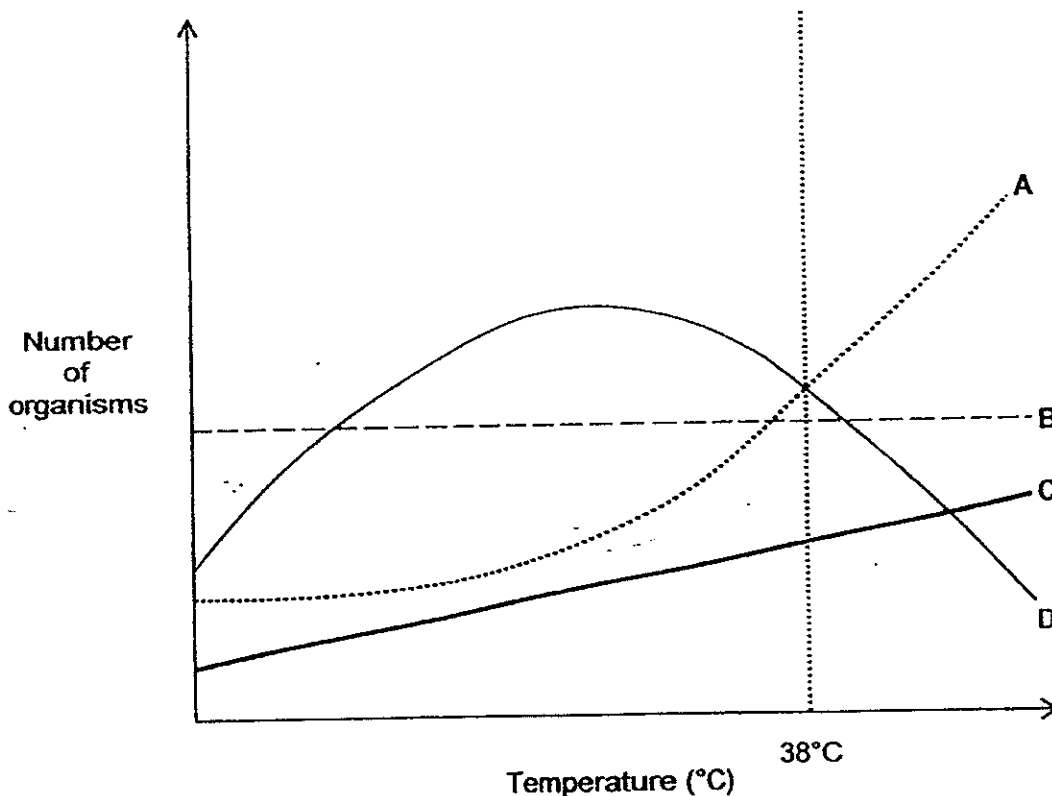

Which of the organisms, A, B, C or D, will survive better when the temperature of the habitat starts to rise above 38°C?

- (1) C only
 (2) A and C only
 (3) B and D only
 (4) A, B and C only

()

End of Booklet A

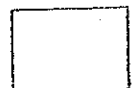





HENRY PARK PRIMARY SCHOOL
2014 SEMESTRAL EXAMINATION 1
PRIMARY 6 SCIENCE
Booklet B

Name: _____ ()

Class: Primary 6 _____

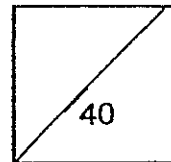

14 Questions
40 Marks

Total Time for Booklet A and B: 1 h 45 min

DO NOT OPEN THIS BOOKLET UNTIL YOU ARE TOLD TO DO SO.

READ AND FOLLOW INSTRUCTIONS CAREFULLY.

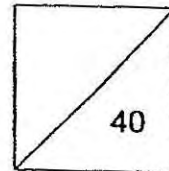

Name: _____ ()

Class: Pr 6 _____

Parent's Signature: _____

Booklet B (40 marks)

Write your answers to questions 31 to 44 in the spaces given.

31. James and Mei Ling went to Bukit Chandra for an excursion and observed animals X and Y as shown below.

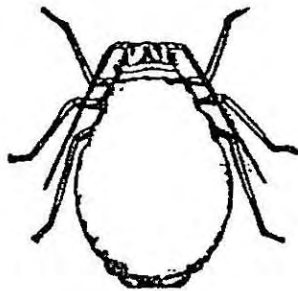

Animal X



Animal Y

The two pupils then came up with a classification chart as shown below.

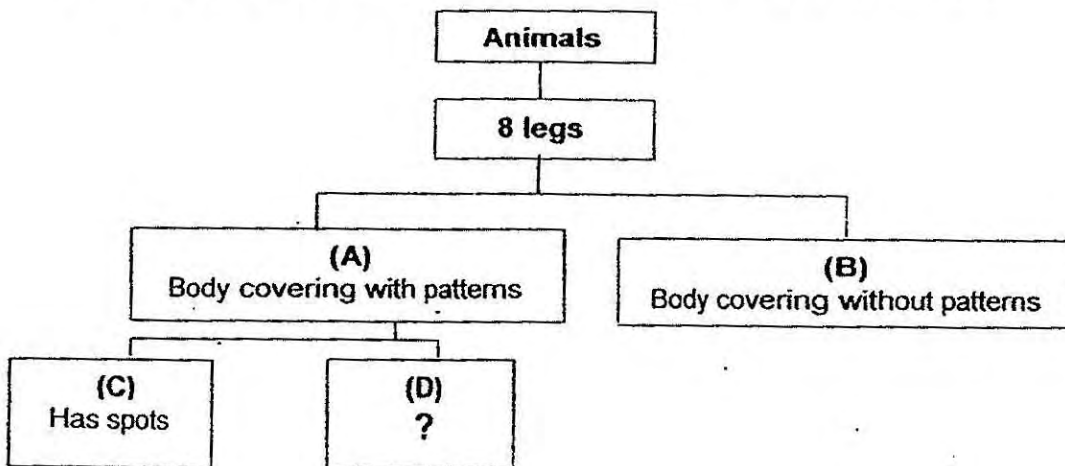

a) Based on the classification chart above, write a suitable heading for (D). (1m)

b) Mei Ling stated that animal X cannot be placed in the classification chart above. (1m)

Do you agree with Mei Ling? Give a reason for your answer.



32. The diagram below shows process G that will be taking place soon in the egg.

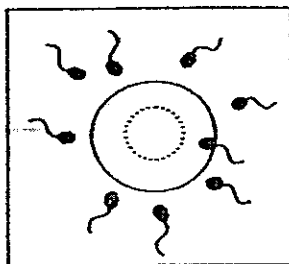

a) What is process G? (1m)

b) Process G also takes place in flowering plants. (1m)

On the diagram of the flower F below, label with an 'X' where process G takes place.

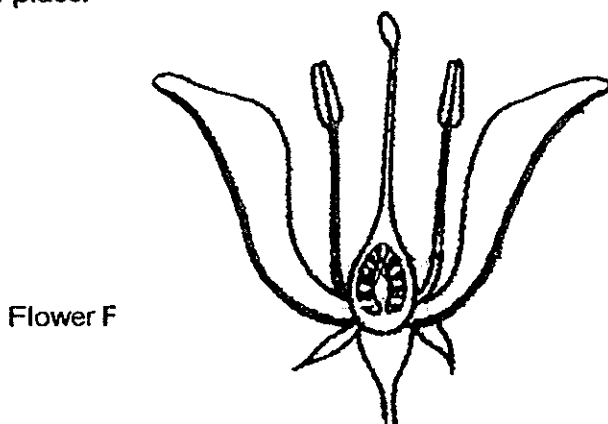

Ahmad saw flower H, as shown below, in his garden.

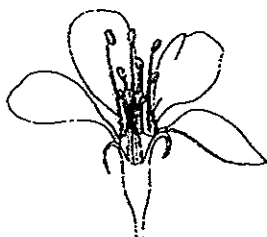

Flower H

c) What will Ahmad observe about flower H that confirms that process G has taken place in the flower successfully? (1m)



33. Four different types of plants (A, B, C and D) were found growing near a river as shown in Diagram X. Diagram Y shows what was observed after 5 years.

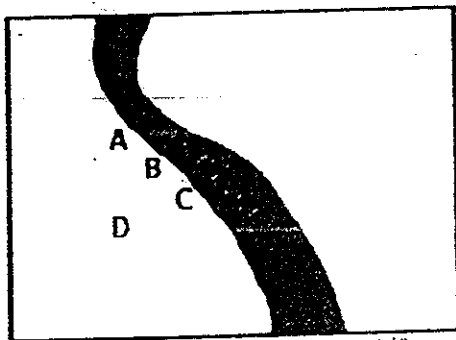

Diagram X

5 years later

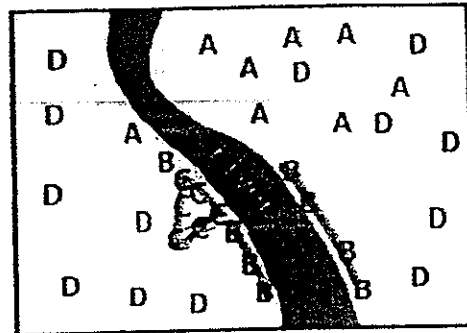
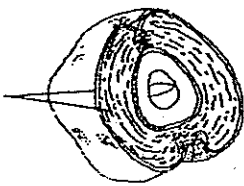
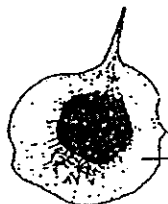

Diagram Y

(1m)

a) The diagram below shows 2 fruits, P and Q.

Identify which plant, A, B, C or D, they came from. Write A, B, C or D in the boxes provided.

<div style="display: flex; align-items: center; margin-bottom: 10px;"> <input style="width: 40px; height: 20px; margin-right: 10px;" type="text"/> <div style="text-align: center;">  </div> </div> <p style="margin-left: 20px;">Fibrous husks</p> <p style="text-align: center; margin-top: 10px;">Fruit P</p>	<div style="display: flex; align-items: center; margin-bottom: 10px;"> <input style="width: 40px; height: 20px; margin-right: 10px;" type="text"/> <div style="text-align: center;">  </div> </div> <p style="margin-left: 20px;">wing-like part</p> <p style="text-align: center; margin-top: 10px;">Fruit Q</p>
--	--

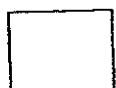

Continued from page 3

The diagram below shows another fruit, Fruit Z.

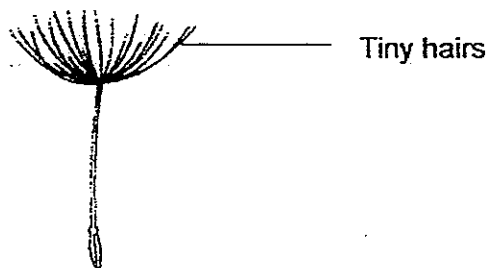

Denny carried out an experiment with Fruit Q and Fruit Z and measured the distance between the seeds of each fruit from their parent plant.

He recorded his results in a table below.

Fruit	Distance between seeds of each fruit and parent plant (km)
Q	2
Z	5

- b) Which fruit, Q or Z, has a more advantageous method of seed dispersal? (1m)

- c) Explain your answer in (b). (1m)

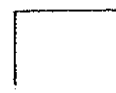

34. Xiaoming wanted to investigate how the surrounding temperature will affect the rate of evaporation of water.

He set up his experiment using three containers, P, Q and R, of the same material. Water was poured into each of them until it reached the same height for all the containers. He then left the containers at different locations with different surrounding temperatures for one day.

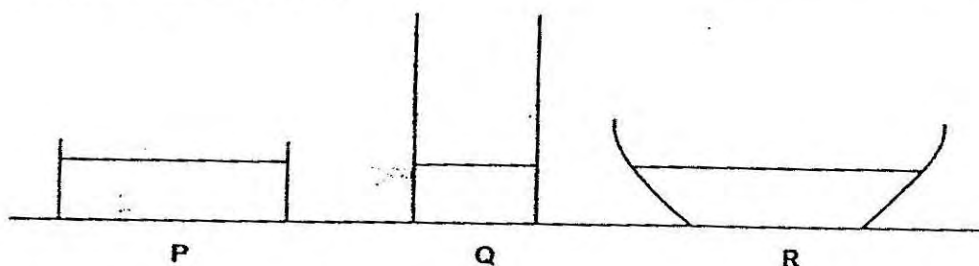

- a) His Science teacher commented that his experiment was not fair. (2m)

State 2 changes he needed to make for a fair experiment.

Change 1:

Change 2:

- b) What can Xiaoming measure to collect results for his experiment? (1m)

As Xiaoming was preparing his experiment, he spilt a puddle of water on the floor. He used a broom to spread the puddle out as shown below.



- c) Explain how his action helped to dry the floor faster. (1m)



35. The diagram shows a seed growing into a young plant.

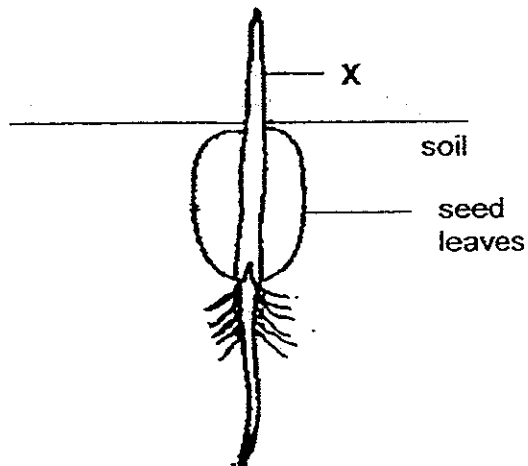

- a) What is the direction in which food and water are being transported at X? (1m)

Write in each box below the word 'upwards' or 'downwards'

Direction for transport of	
Food	Water

- b) Name the part of the seed that provides the young plant with food. (1m)

- c) Name the part of the seed that grows out first. (1m)



36. In an experiment, Ahmad constructed a circuit card with six metal buttons, A, B, C, D, E and F, and a piece of cardboard.

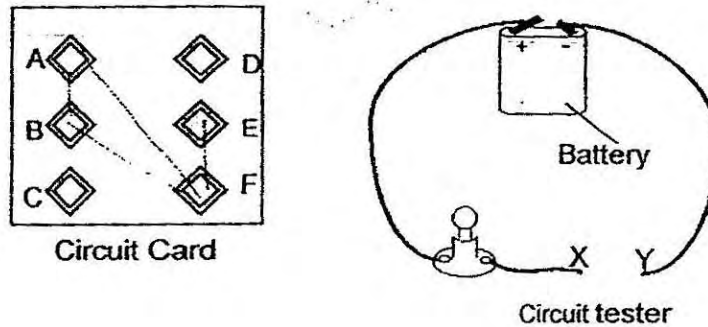

On the back of the cardboard he connected the six metal buttons using some wires. The following table shows what happened to the bulb in the circuit tester when points X and Y of the circuit tester was connected to a pair of metal buttons on the circuit card.

Buttons connected by wire	Did the bulb light up?
A and B	Yes
A and F	Yes
C and E	No
B and F	Yes
E and F	Yes
A and D	No

- (a) On the incomplete circuit card shown below, **draw 2 more wires** to connect all relevant buttons such that information given in the table above is correct. (1m)

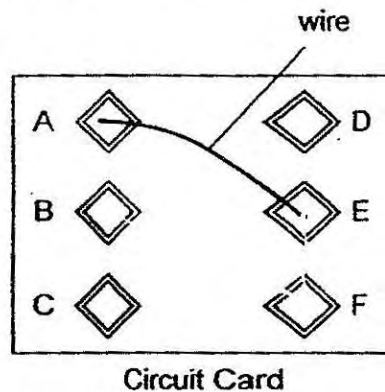

continued from page 7

- (b) Joy wants to find out if the number of bulbs, arranged in parallel, will affect the brightness of bulbs. Joy sets up two circuits, P and Q, to conduct the experiment.

Circuit P is drawn below. Draw a circuit diagram to represent Circuit Q in the box below. (2m)

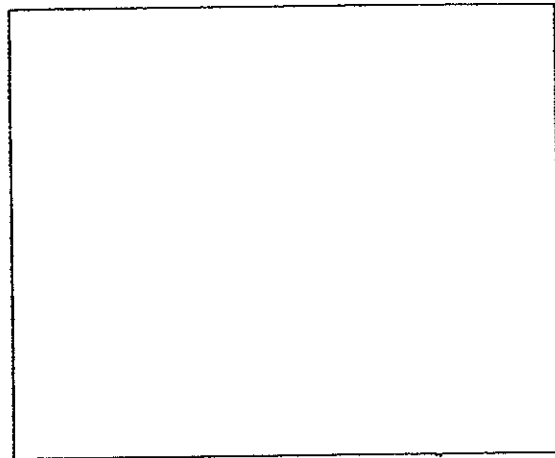
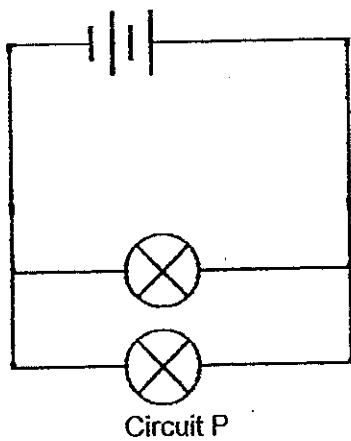

Circuit Q



37. A green leaf from a plant was covered with black paper with star cut-outs as shown in the diagram below.

The plant was left in the open for 48 hours before a starch test was performed on this leaf.

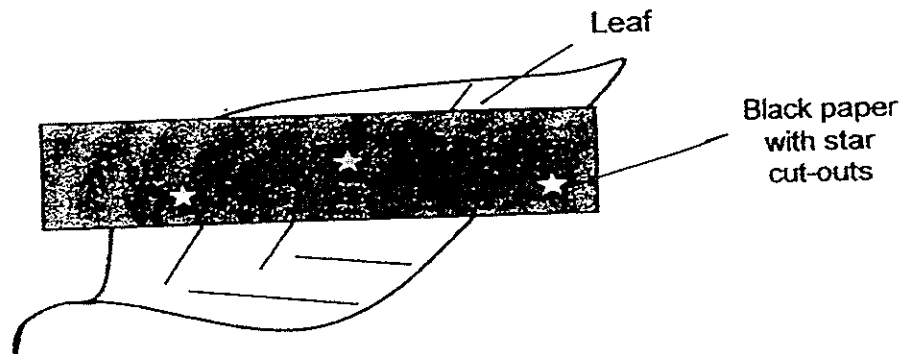

The plant was de-starched before the experiment was conducted.

- a) In the box given below, when the black paper is removed, **shade** the parts of the leaf where the iodine solution, when added, turns dark blue. (1m)

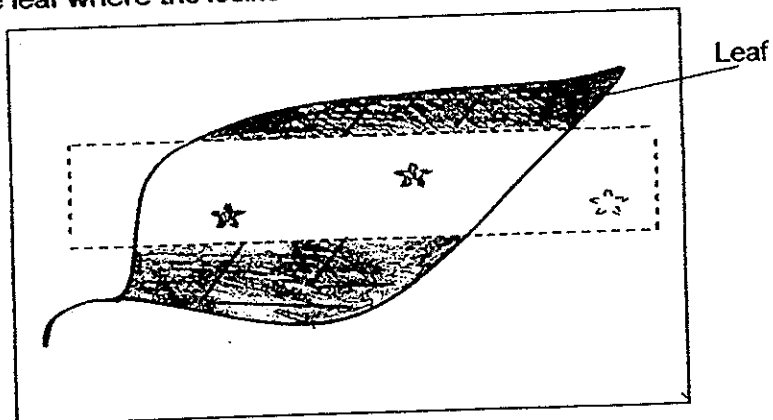

- b) Explain why the iodine solution remains yellowish brown on some parts of the leaf. (2m)

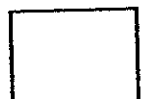

38. Mary conducted an experiment as shown in the diagram below.

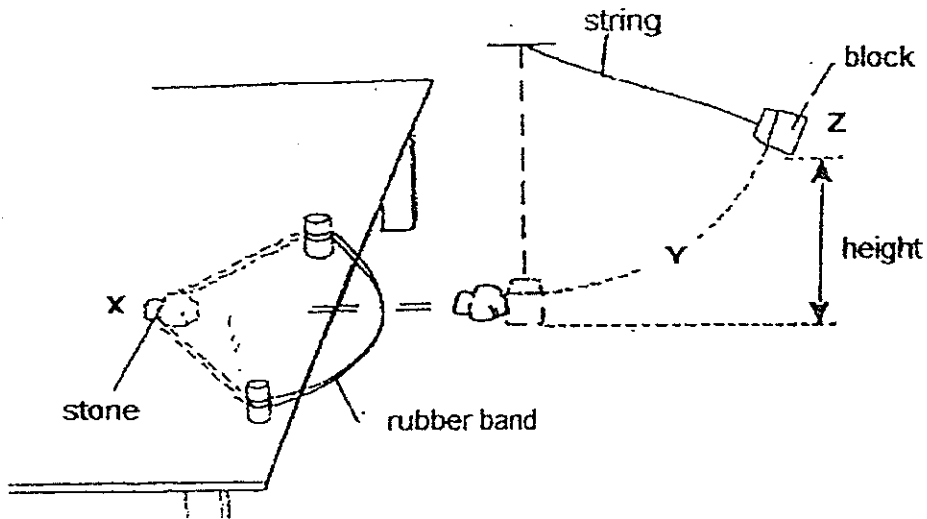

She pulled the rubber band backwards together with a stone to position X. When she released the stone, it moved forward and hit the block.

The block, which was suspended by a string, swung upwards to position Y and then position Z before falling back.

- a) State the energy conversion from position X to position Y. (2m)

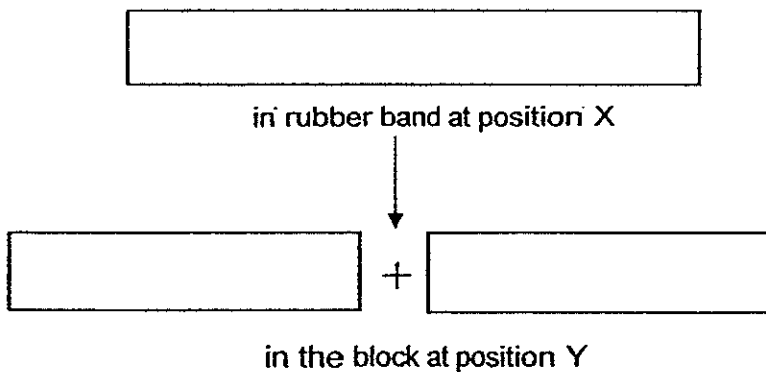

- b) Suggest two methods that will cause the block to swing higher than position Z. (2m)

Method 1: _____

Method 2: _____



39. Two similar glass jars, X and Y, which contained 100g of soil each, were placed under the Sun next to each other. Jar X was covered with a lid while jar Y was left open.

A thermometer was placed into each jar and the temperature of the air inside each jar was measured at hourly intervals for 3 hours.

The table below shows the temperature readings of the air in the two jars.

Temperature reading	Temperature (°C) at different times			
	10am	11am	12pm	1pm
Set A	30	32	39	45
Set B	30	33	37	40

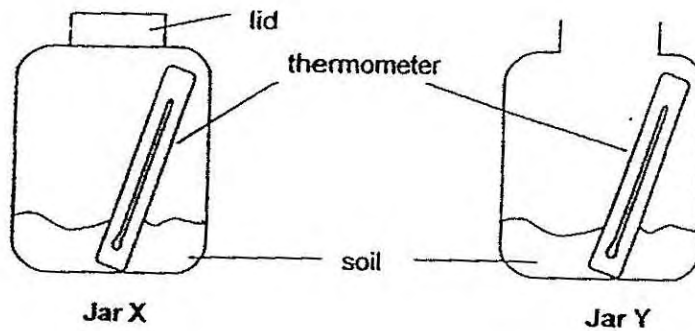

- a) The temperature of air in both jars X and Y increased at the end of the experiment. (1m)

Explain why this is so.

- b) Which set of readings, A or B, will more likely represent the temperature of air in jar Y? Explain your answer. (2m)



40. The diagram below shows a hydroelectric power station. The arrows show the movement of water.

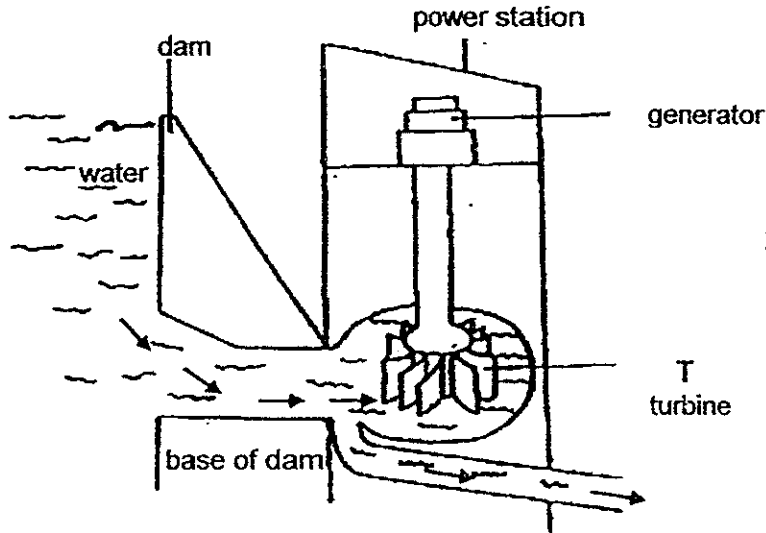

At Point T, the turbine turns to generate electricity.

Explain how the turbine is able to turn.

(2m)



41. In an experiment, Walter placed a toy car on a cardboard and object X below it as shown in diagram 1.

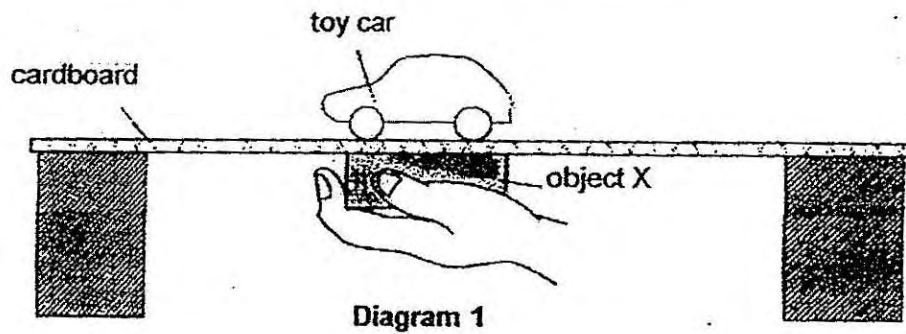

- a) Walter moved object X and the toy car moved in the same direction as object X. (1m)
Explain why this is so.

In another experiment, Walter used the same toy car on a thicker cardboard and placed object X below it as shown in diagram 2.

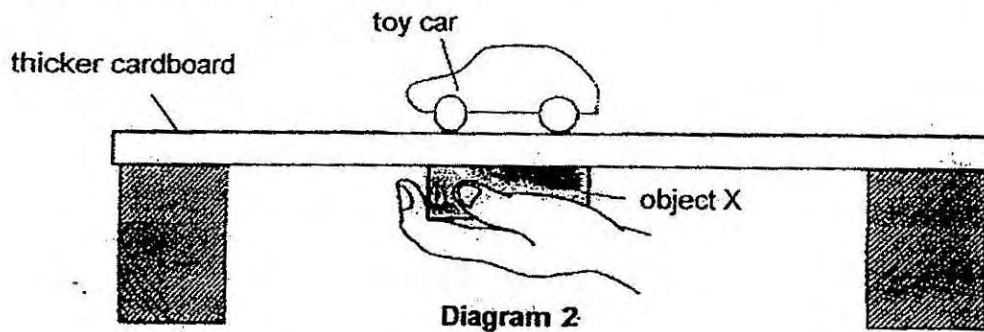

- b) When Walter moved object X, the toy car did not move at all.
Explain why the toy car did not move when a thicker cardboard is used. (1m)

- c) Using the same method, suggest what Walter can do to make the toy car move when the thicker cardboard is used. (1m)



42. Diagram 1 shows the set-up of an experiment with three metal rods, A, B and C, each of the same size and length, three identical magnets and springs.

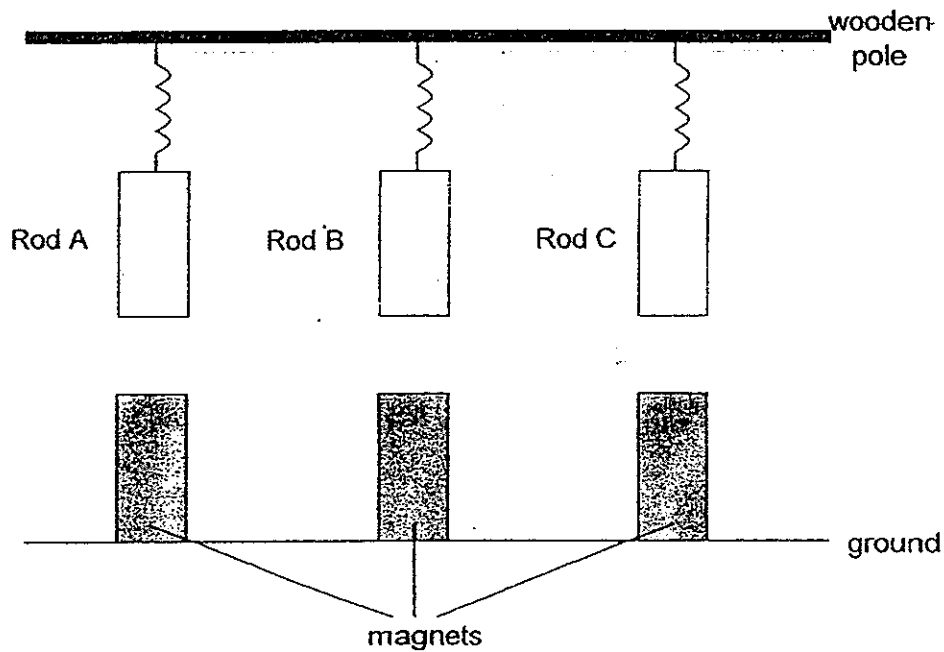

Diagram 1

Diagram 2 shows the results of the experiment.

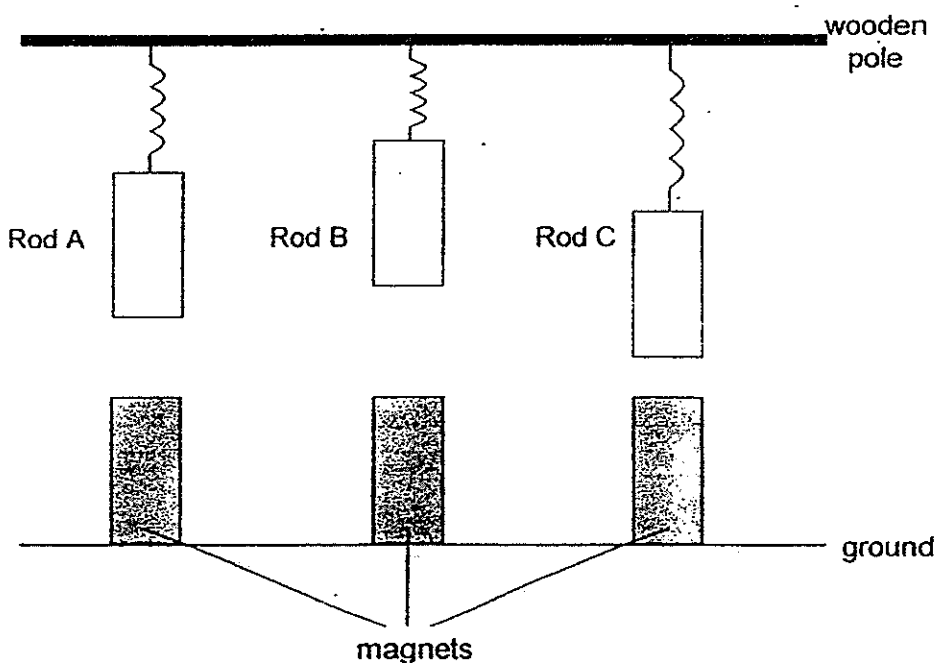

Diagram 2



continued from page 14

a) Based on your observation in Diagram 2, state which rod, A, B or C is (1m)

(i) a magnet : _____

(ii) a non-magnetic metal : _____

b) Give a reason for your answer in (a)(i). (2m)



43. Mr Tan made a study of two types of animals, birds and earthworms, in a particular habitat. The number of birds and earthworms were counted and the weather condition and temperature were noted over a period of five days.

The results of the study are shown below.

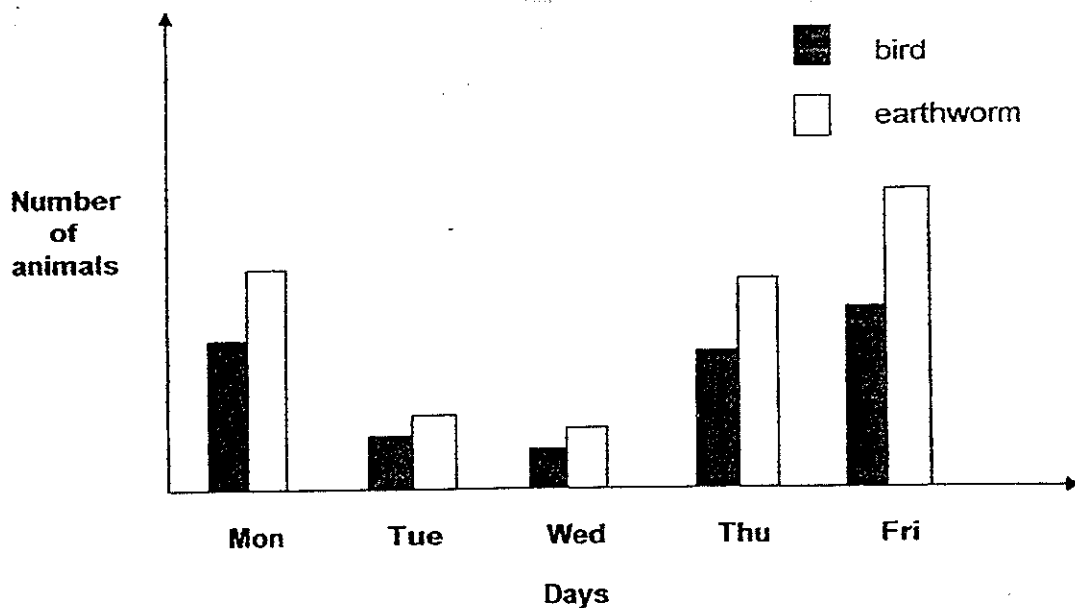

Day	Monday	Tuesday	Wednesday	Thursday	Friday
Weather condition	Rainy	Sunny	Sunny	Rainy	Rainy
Temperature (°C)	27	31	32	28	26

Describe how the **weather condition** and **temperature** affect the number of birds and earthworms observed over the five days. (2m)



44. Mrs Tan has difficulty removing the jade bangle on her wrist as shown below.

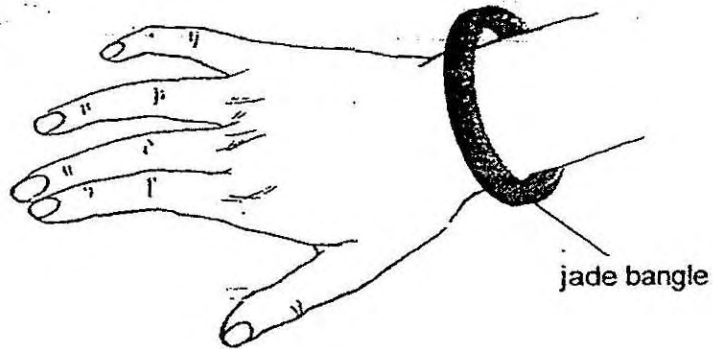

a) Suggest a method for Mrs Tan to remove the jade bangle without breaking it. (1m)

b) Give a reason for your answer. (1m)

End of Booklet B

Setters:
Mdm Cecilia Quah
Mrs Liu Ying Hui
Mr Tan Joo Nam



EXAM PAPER 2014**LEVEL : PRIMARY 6****SCHOOL : HENRY PARK****SUBJECT : SCIENCE****TERM : SA1**

Q1	4	Q7	3	Q13	1	Q19	1	Q25	3
Q2	2	Q8	4	Q14	1	Q20	2	Q26	4
Q3	2	Q9	1	Q15	1	Q21	3	Q27	3
Q4	3	Q10	2	Q16	3	Q22	2	Q28	2
Q5	1	Q11	2	Q17	4	Q23	3	Q29	2
Q6	2	Q12	1	Q18	4	Q24	1	Q30	2

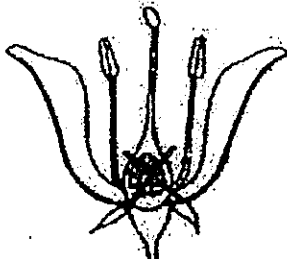
Q31	(a)	Has no spots
	(b)	Yes. The chart is for animals with 8 legs while X has only 6 legs.
Q32	(a)	Fertilisation
	(b)	
	(c)	It will start developing into a fruit and the petals would drop off.
Q33	(a)	Fruit P : B Fruit Q : A
	(b)	Z
	(c)	As it can fly further from the parent plant, it will enable the seeds to be more spread out, reducing the chance of overcrowding, allowing the seedlings to grow healthily without having to compete over sunlight, water and nutrients.
Q34	(a)	Change 1: Ensure the containers have the same exposed surface. Change 2: Ensure that the amount of water poured into each container is the same.
	(b)	The amount of water left in each container after a certain period of time.
	(c)	Spreading out the puddle of water enables the puddle to have a larger exposed surface area of water increasing the rate of evaporation of the water.
Q35	(a)	Food : upwards Water : upwards
	(b)	Seed leaves
	(c)	Roots

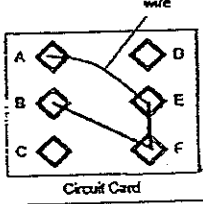
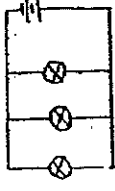
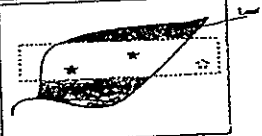
Q36	(a)	 <p style="text-align: center;">Circuit Card</p>
	(b)	 <p style="text-align: center;">Circuit Q</p>
Q37	(a)	
	(b)	<p>When the iodine turns yellowish brown, this shows that those parts of the leaf have no starch present. This happened as the black paper covered some parts of the leaf preventing sunlight from reaching these parts. Without sunlight, the leaf would not be able to make food and no sugar was produced to be converted to starch.</p>
Q38	(a)	<p>Elastic Potential Energy Kinetic Energy Gravitational Potential Energy</p>
	(b)	<p>Method 1: Use a lighter block Method 2: Use more rubber bands</p>
Q39	(a)	<p>They were both placed under the sun. The air inside both jar gain heat from the sun thus there is an increase in temperature of the air.</p>
	(b)	<p>Set B. As it is not covered with a lid thus allowing warm air to escape from the jar and will be replaced by cooler air resulting in lower temperature of the air.</p>
Q40		<p>The water behind the dam has GPE which is converted to KE, thus causes the turbine to turn.</p>
Q41	(a)	<p>X could be a magnet and the toy could have been made of magnetic materials. Moreover, cardboard is not a magnetic material. Hence, magnetism can pass through the cardboard and attract the car so as the object X moves, the car attracted to it follows.</p>
	(b)	<p>The distance between the magnet and the toy car has increased, thus not being able to attract the toy car. This resulted on the toy car not being able to move.</p>
	(c)	<p>He could use a stronger magnet.</p>
Q42	(a)	<p>(i) Rod B (ii) Rod A</p>
	(b)	<p>Rod A was not attracted to the magnets showing that is it not a magnetic material. Rod B had repelled the magnet and the spring holding it was compressed.</p>