



**NAN HUA PRIMARY SCHOOL
CONTINUAL ASSESSMENT 1 2017
PRIMARY SIX
SCIENCE**

Name : _____ ()

Class : Primary 6 / ____

Date : 1 March 2017

Duration : 1 hr 45 min







| MARKS | |
|----------------|--------------|
| Sect A: | / 56 |
| Sect B: | / 44 |
| Total : | / 100 |

Parent's Signature : _____

Section A: (28 x 2 marks = 56 marks)

For each question from 1 to 28, four options are given. One of them is the correct answer. Make your choice (1, 2, 3 or 4). Shade the correct oval (1, 2, 3 or 4) on the Optical Answer Sheet.

1. Study the classification table below carefully.

| Group A | Group B |
|--|---|
|  Honeydew Melon  Chilli  Lady's finger |  Bread mould  Mushroom  Fern |

Which of the following headings correctly represent groups A and B?

| | Group A | Group B |
|-----|--------------------|---------------------|
| (1) | Fruit | Fungi |
| (2) | Edible | Inedible |
| (3) | Dispersed by water | Dispersed by wind |
| (4) | Reproduce by seeds | Reproduce by spores |

2. The diagram below shows the female human reproductive system.

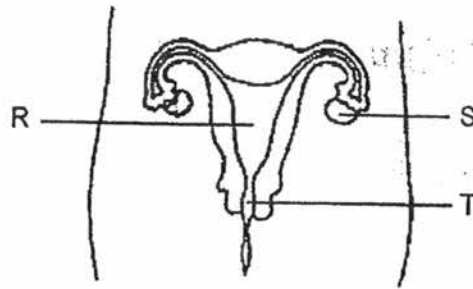

Which of the following statement(s) is/are correct?

- A Fertilisation takes place at T.
- B The unfertilised eggs are produced by S.
- C The developing baby develops in R for about nine months.

- (1) A only
- (2) B only
- (3) A and C only
- (4) B and C only

3. The diagram below shows a plant cell.

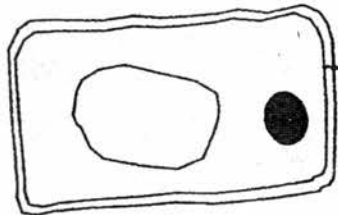

The pictures below show parts of plants where the cell could have been taken from.

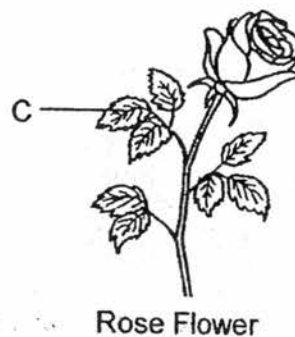
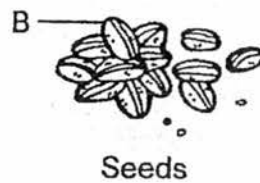

Which part(s) could the cell be taken from?

- (1) A only
- (2) B only
- (3) A and B only
- (4) A, B and C

4. A snail and a water plant were placed into two identical test tubes containing the same amount of water as shown in the diagram below. Both test tubes were placed in a brightly lit room for a week.

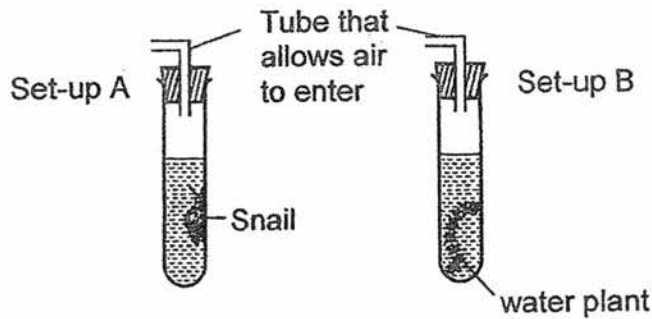

Based on the experiment above, which statement is true?

- (1) The snail would die first as it has no food whereas the water plant could make its own food.
 - (2) The plant would die first as there was no snail to provide carbon dioxide for it to photosynthesize.
 - (3) The snail would die first as the dissolved oxygen in the water was used up by the snail for respiration.
 - (4) The snail and the plant would die at the same time as the dissolved oxygen in the water was used up for respiration.
5. A plant was placed in a black box with a hole made on the right side as shown in the diagram below. The boxes were placed by the window for three days.

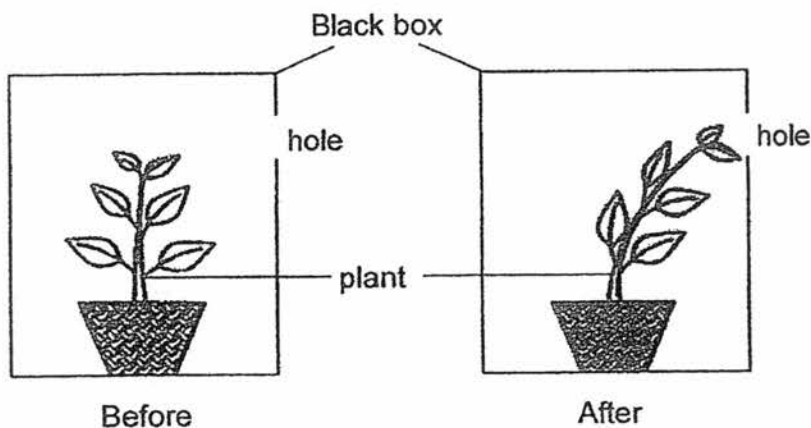

Which of the following can be concluded from the observation above?

- A Plants can make food.
- B Plants can respond to changes.
- C Plants need food, water and sunlight.

- (1) A only
- (2) B only
- (3) A and C only
- (4) B and C only

6. The graph below shows the amount of food eaten at various stages in the life cycle of the butterfly.

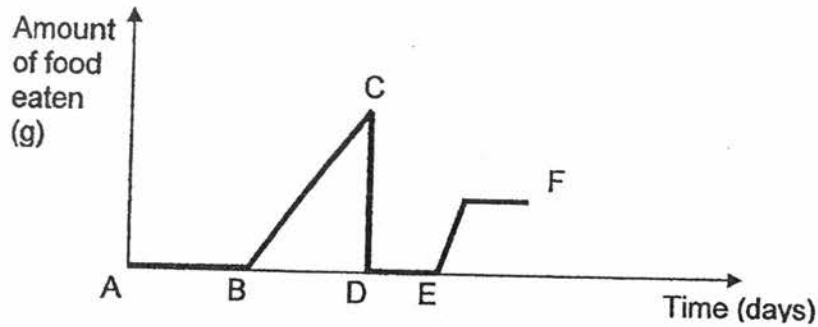

Which part of the line graph shows the larva and pupa stages?

| | Larva stage | Pupa stage |
|-----|-------------|------------|
| (1) | AB | BC |
| (2) | BC | DE |
| (3) | CD | DE |
| (4) | AB | EF |

7. Jack wants to set up an experiment to find out if seeds need light to germinate. He prepared four petri-dishes as shown below.

placed under light

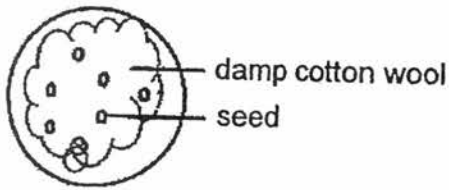

A

placed in darkness

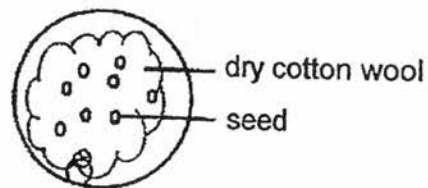

B

placed under light

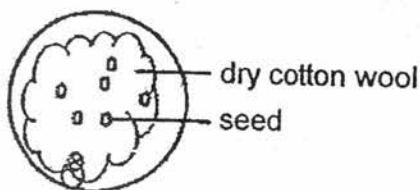

C

placed in darkness

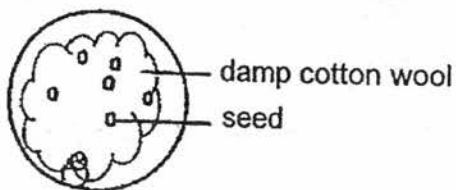

D

Which two petri-dishes should he choose for his experiment?

- (1) A and B
- (2) A and D
- (3) B and C
- (4) C and D

8. The diagram below shows how food and various gases are transported in the human body.

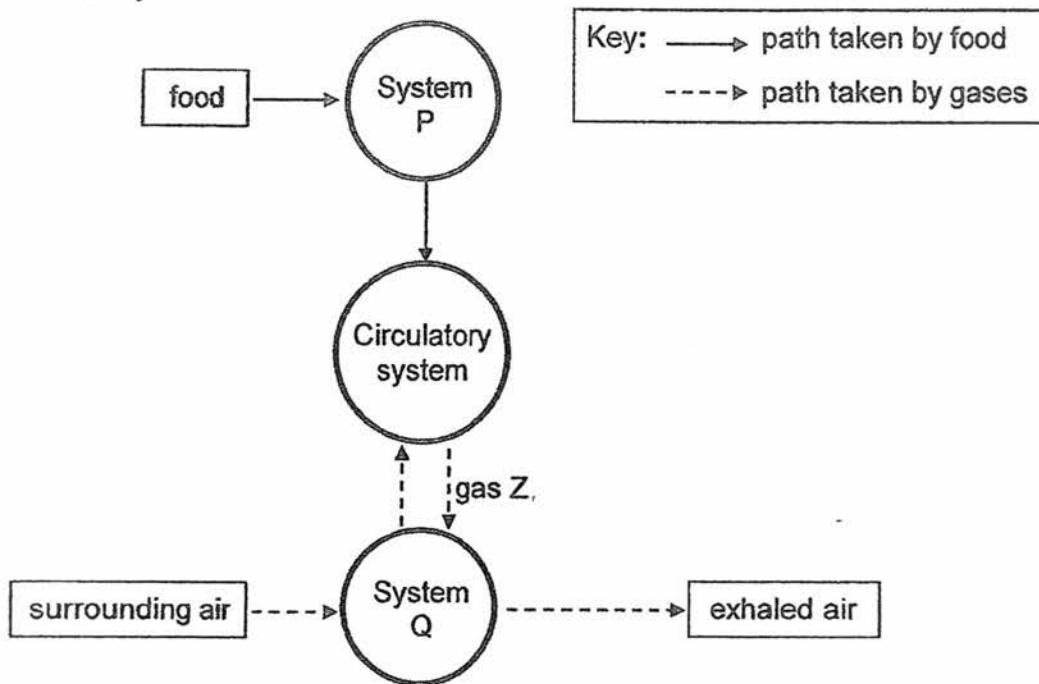

Identify system P, system Q and gas Z.

| | System P | System Q | Gas Z |
|-----|-----------------|-----------------|----------------|
| (1) | Digestive | Respiratory | Oxygen |
| (2) | Respiratory | Digestive | Oxygen |
| (3) | Respiratory | Digestive | Carbon dioxide |
| (4) | Digestive | Respiratory | Carbon dioxide |

9. The diagrams below show the direction of the flow of materials in the human circulatory system and the plant transport system.

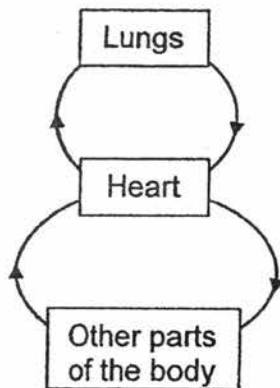

Human Circulatory System

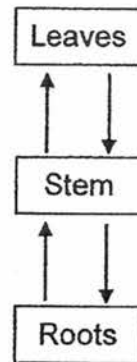

Plant Transport System

Which statement(s) about the two systems is/are correct?

- A Both systems transport exactly the same materials.
- B The plant transport system has two different types of tubes whereas the human circulatory system has blood vessels.
- C The human circulatory system has a heart to move materials around whereas the roots pump materials from the soil up to the leaves.

- (1) A only
- (2) B only
- (3) A and C only
- (4) B and C only

10. Study the diagram below carefully.

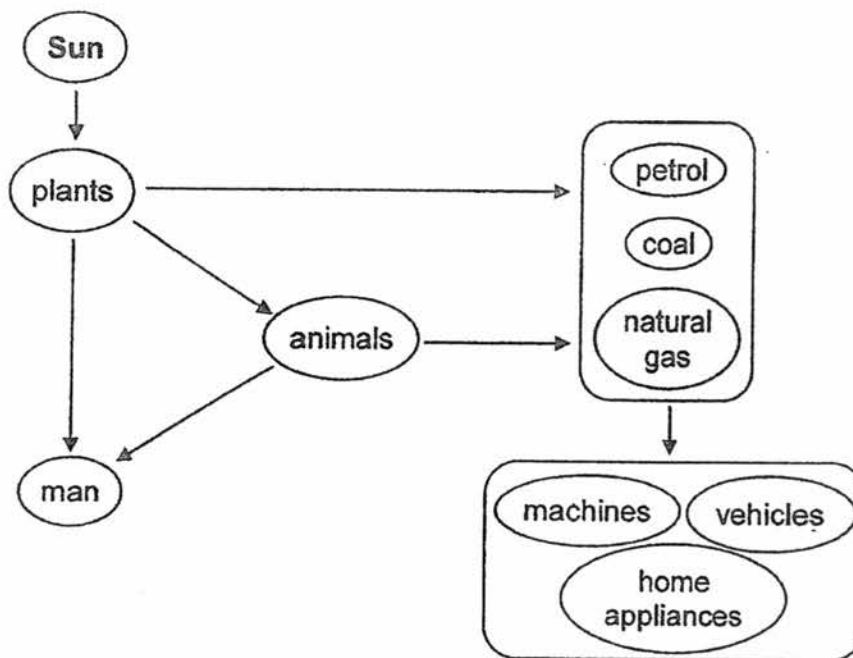

Based on the diagram, which statements are true?

- A The Sun is the main source of energy.
- B The arrows show how food is obtained.
- C The arrows show the direction of energy transfer.

- (1) A and B only
- (2) A and C only
- (3) B and C only
- (4) A, B and C

11. There has been a lot of focus on alternative sources of energy such as the Sun and the wind.

Solar Energy



Wind Energy



Which of the statements below explain why there is so much focus on harnessing energy from the Sun and the wind?

- A Wind and sunlight are easily available.
- B New technologies are more interesting to use.
- C We have plenty of land to build wind turbines and solar panels.
- D We cannot rely on the same source of energy which can run out one day.

- (1) A and C only
- (2) A and D only
- (3) B and C only
- (4) B and D only

12. Study the diagrams below carefully.

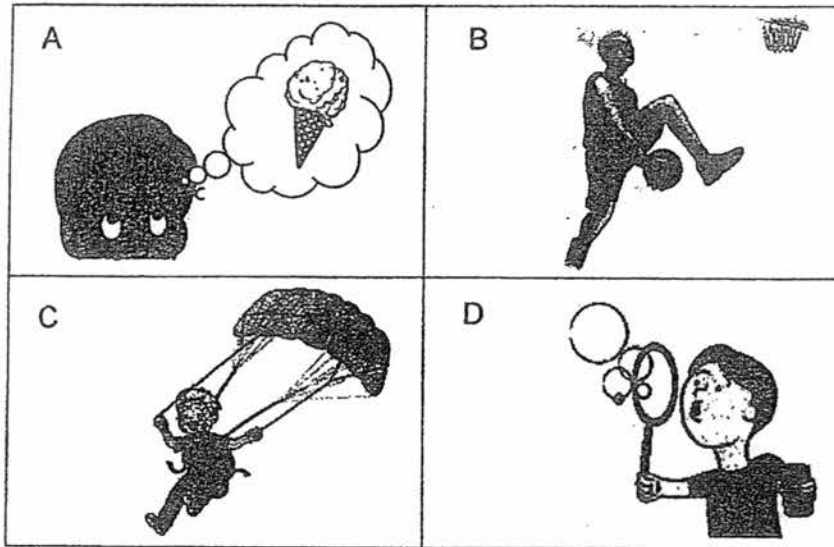

Which activity **does not** involve a force?

- (1) A
- (2) B
- (3) C
- (4) D

13. The diagram below shows someone pushing a balloon into a container of water.

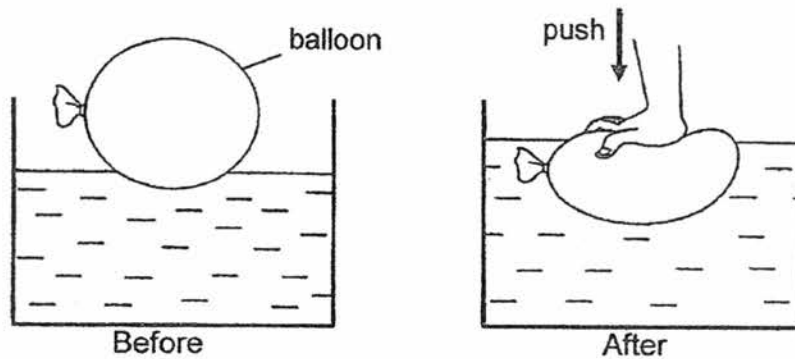

What is/are the effect(s) of the force on the balloon?

- A Stop a moving balloon
- B Move the stationary balloon
- C Change the shape of the balloon

- (1) A only
- (2) C only
- (3) A and B only
- (4) B and C only

14. The diagram below shows a girl jumping on a trampoline.

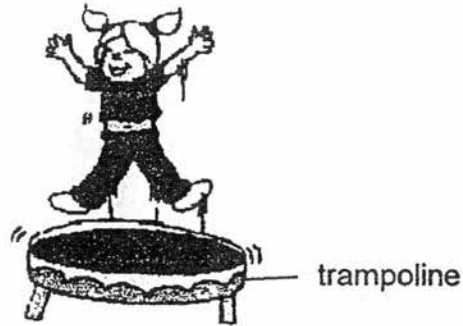

What force(s) is/are involved that enabled the girl to do the activity?

- (1) Gravitational force only
 - (2) Gravitational force and frictional force only
 - (3) Elastic spring force and frictional force only
 - (4) Gravitational force, elastic spring force and frictional force
15. During a science lesson, each pupil was given a bulb, two batteries and all the other necessary parts to make a circuit that would light up the bulb.

If all the parts are connected but the bulb did not light up, what could be a possible reason?

- (1) Only one battery was used.
 - (2) A switch was not added to the circuit.
 - (3) Some rubber covering around the wire had come off.
 - (4) The same terminals of the batteries were facing each other.
16. A ball which is released in a bowl at point A rolls to B and then to C as shown below.

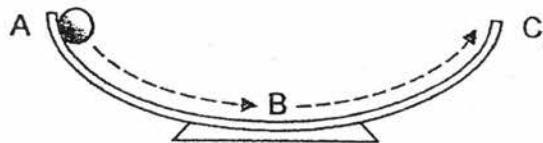

Which of the following correctly shows the changes in the potential energy and kinetic energy of the ball as it rolls from A to C?

| | Change in kinetic energy from A to B | Change in potential energy from B to C |
|-----|--------------------------------------|--|
| (1) | increase | increase |
| (2) | decrease | decrease |
| (3) | decrease | increase |
| (4) | increase | decrease |

17. The diagram below shows a set-up that uses a light sensor to count the number of identical canned food moving on a belt.

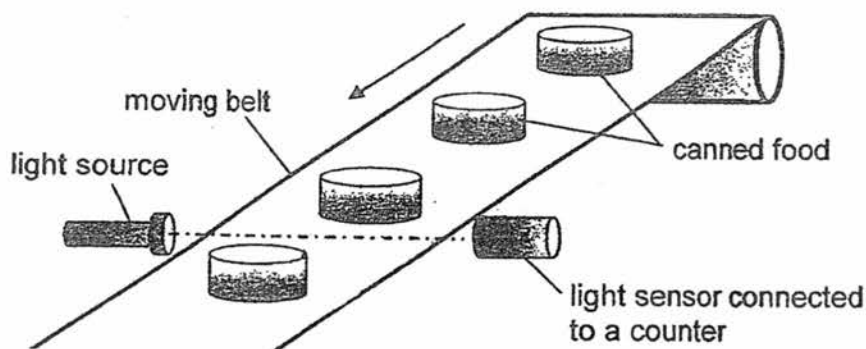

The belt moves at a constant speed. When a can is between the light source and the sensor, it blocks the light from reaching the sensor.

Which graph correctly shows the data recorded by the light sensor?

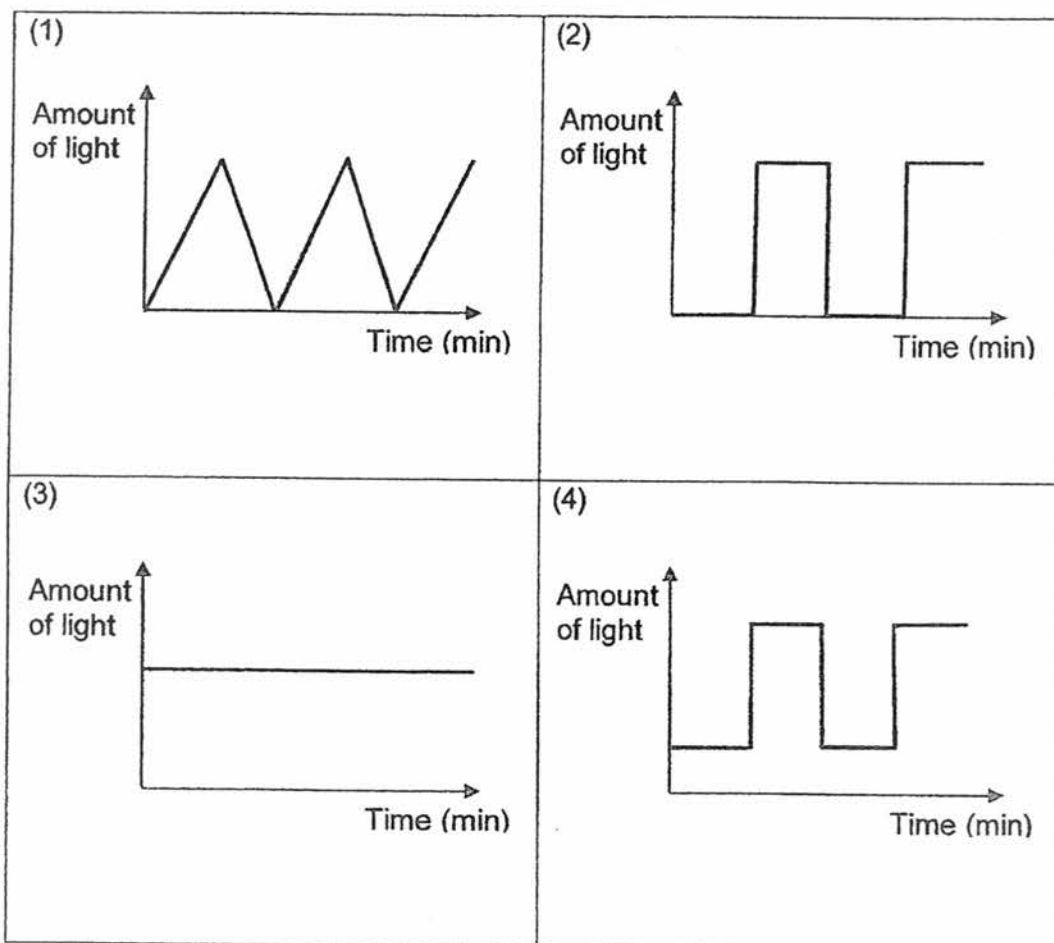

18. A bottle of cold milk is placed in a hot water bath.

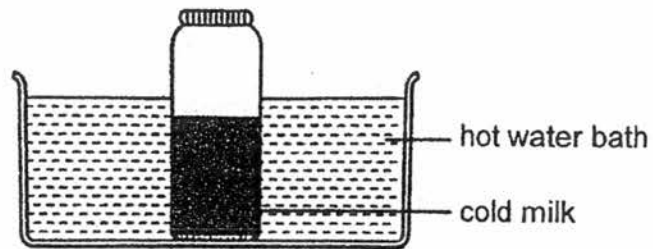

Which statements correctly describe what will happen in the set-up?

- A Heat travelled from the water to the milk.
- B The temperature of the milk will increase.
- C The temperature of water will not change since there is a lot of water.
- D The temperature of the milk and the water will eventually be the same.

- (1) A and B only
- (2) C and D only
- (3) A, B and D only
- (4) B, C and D only

19. Clara conducted an experiment using a wooden block X and a flat wooden plank YZ. In Figure 1, block X was placed on wooden plank YZ that was placed horizontally. He raised the end Y of the plank slightly as shown in Figure 2 but the block did not slide down.

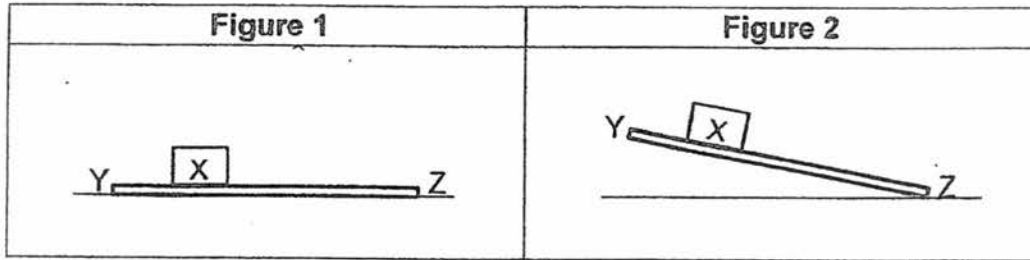

Which of the following statements is/are correct?

- (1) Frictional force acted on block X in Figure 1.
 - (2) Frictional force acted on block X in Figure 2.
 - (3) No frictional force acted on block X in Figure 1 and Figure 2.
 - (4) There is more frictional force between block X and the plank in Figure 1 than in Figure 2.
20. Gravitational force acted on the skateboarder so he moved down from point A.

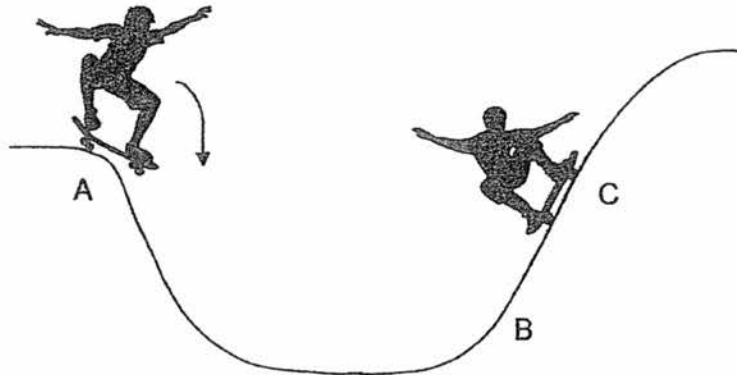

When the skateboarder is moving from B to C, what is/are the force(s) acting on him that slows him down?

- A Magnetic force
 B Frictional force
 C Gravitational force

- (1) A only
- (2) C only
- (3) B and C only
- (4) A, B and C

21. Pria conducted an experiment on springs A and B that have the same original length of 8 cm. She placed identical wooden blocks on both springs as shown below.

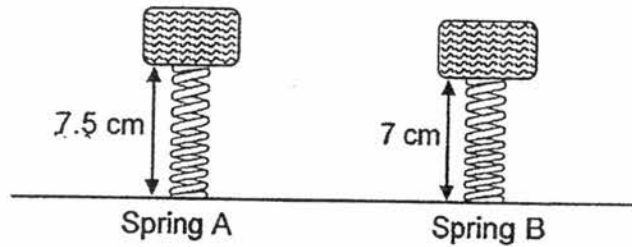

As she continued to add more identical wooden blocks to both springs, which statement is true?

- (1) For every wooden block added, the length of Spring A was longer than Spring B.
 - (2) When the same load was added to both springs, Spring B compressed less than Spring A.
 - (3) If more load was added to both springs, Spring A would be completely compressed first.
 - (4) When the first wooden block was placed on both springs, Spring B stretched less than Spring A.
22. Isaac carried out an experiment using an electromagnet he made to attract as many paper clips as possible.

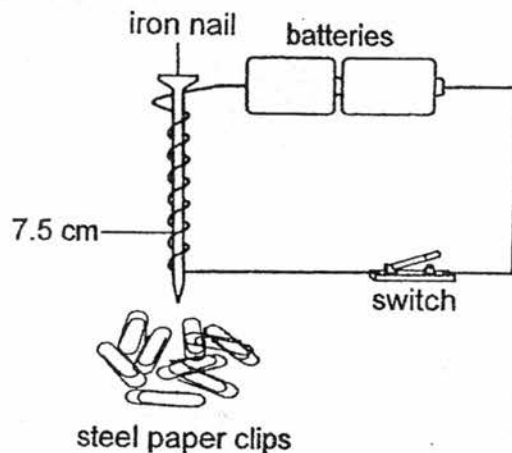

Which of the method(s) will not enable the iron nail to attract more paper clips?

- A Use a longer iron nail.
 - B Add another battery in series to the batteries.
 - C Increase the length of the wire connecting every part in the circuit.
 - D Keep the switch closed for a longer time to magnetise the iron nail.
- (1) B only
 - (2) A, B and C only
 - (3) A, C and D only
 - (4) B, C and D only

23. A circuit card is tested with a circuit tester and the results are recorded in the table below.

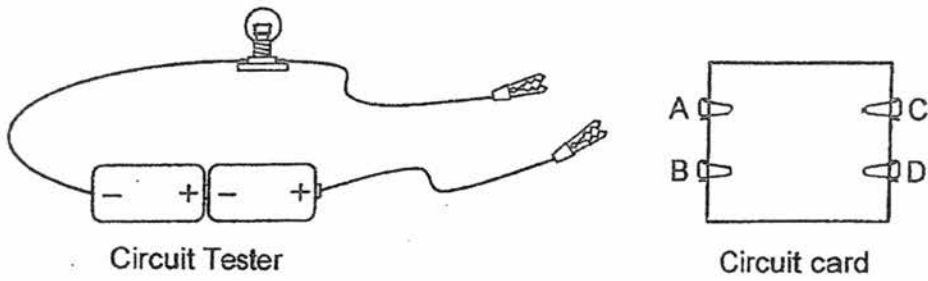

| Pairs of clips | Did the bulb light up? | |
|----------------|------------------------|----|
| | Yes | No |
| A and C | ✓ | |
| B and D | | ✓ |
| C and D | ✓ | |

Which of the following can the circuit card be?

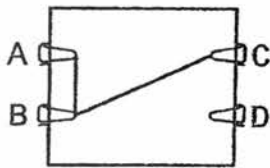

(1)

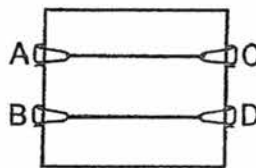

(2)

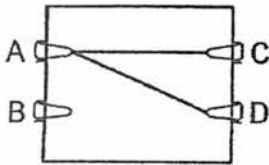

(3)

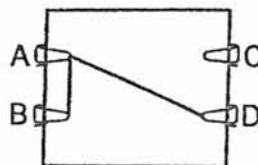

(4)

24. The diagram below shows a simple circuit.

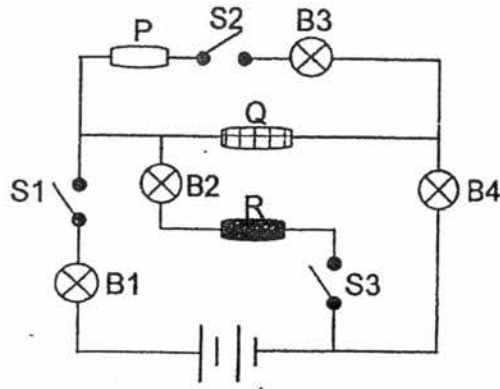

The table below shows the bulbs that lit up when various switches were closed.

| Switches that were closed | Bulbs that lit up |
|---------------------------|-------------------|
| S1 | None |
| S1, S2 | B1, B3, B4 |
| S1, S3 | B1, B2 |

Based on the observations, which of the following correctly identify the electrical conductor(s) and insulator(s)?

| | Electrical conductor | Electrical insulator |
|-----|----------------------|----------------------|
| (1) | P, R | Q |
| (2) | Q | P, R |
| (3) | P, Q | R |
| (4) | R | P, Q |

25. Some ice is placed in a beaker and heated over time. The graph below shows the change in temperature over time.

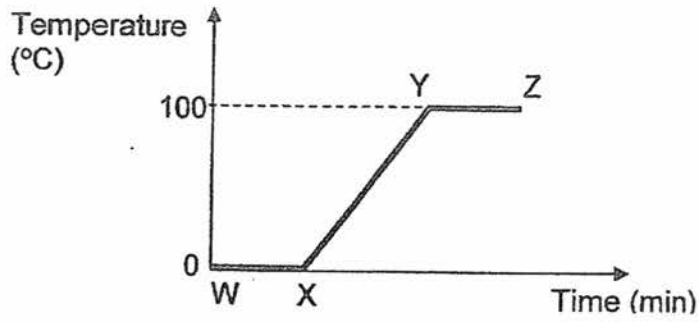

In the diagram below, A, B, C, D, E and F represent the processes responsible for the change of state of water.

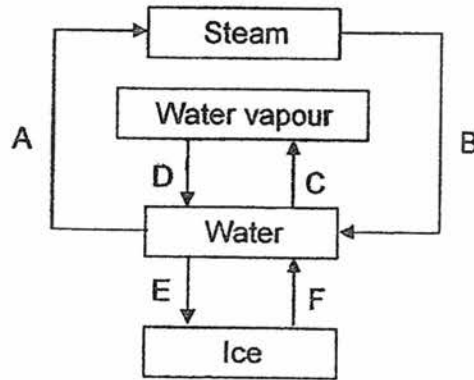

Which of the following correctly matches the processes, A, B, C, D, E and F, to the various parts of the graph?

| | WX | XY | YZ |
|-----|----|----|----|
| (1) | F | D | C |
| (2) | E | C | A |
| (3) | E | D | B |
| (4) | F | C | A |

26. Four rooms, P, Q, R and S, are separated by 3 glass panels. Water droplets were formed on different sides of the glass panels as shown in the diagram below.

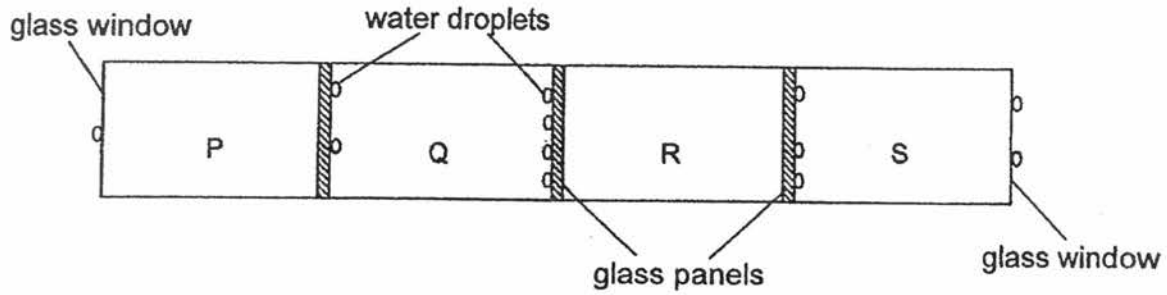

Which is the coldest room?

- (1) P
- (2) Q
- (3) R
- (4) S

27. The diagram below shows two inverted cups, one with a hole at the bottom and one without, being pushed into a basin of water with a piece of cork floating on the water.

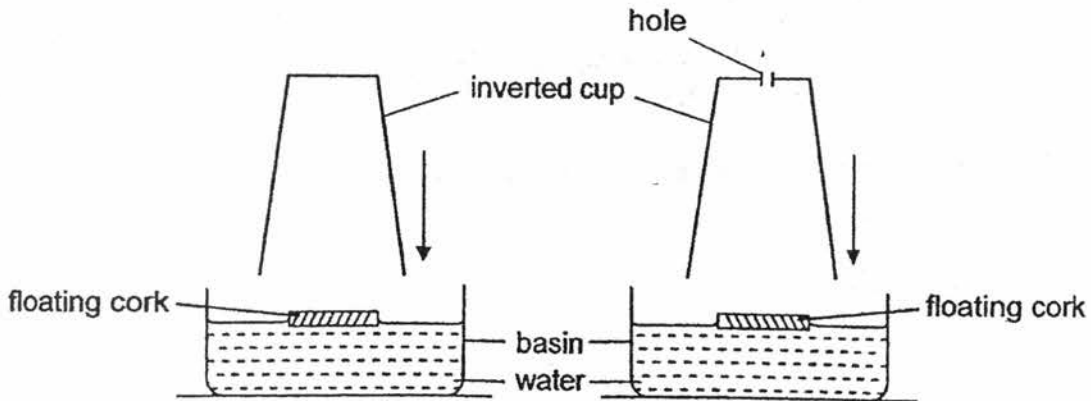

Which of the diagrams show the possible outcomes after the inverted cups are pushed completely into the basin?

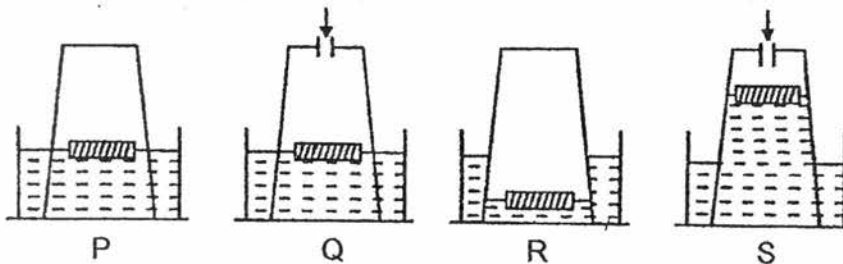

- (1) P and Q only
- (2) P and S only
- (3) Q and R only
- (4) R and S only

28. Matthew prepared the set-up below.

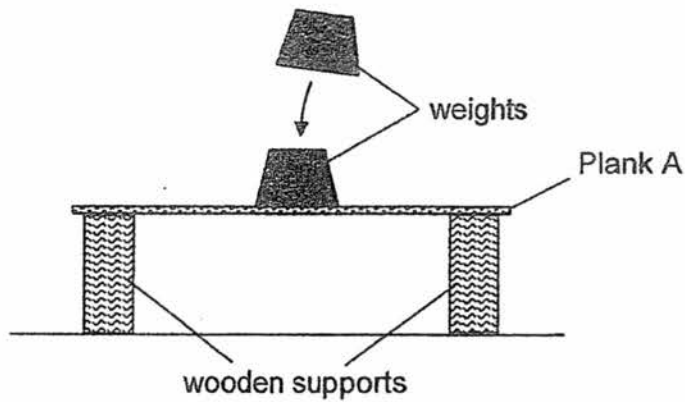

He kept stacking weights in the middle of the plank until it broke and recorded the number of weights needed to break it. He then replaced the plank with Plank B, which is made of another material, and repeated the experiment.

Based on the experiment, which statement is correct?

- (1) The variable changed in the experiment is the number of weights.
- (2) The plank that broke with more weights stacked on top is more flexible.
- (3) The aim of the experiment is to find out if Plank A was stronger than Plank B.
- (4) The plank that broke with fewer weights stacked on top is made of a stronger material.

End of Section A



NAN HUA PRIMARY SCHOOL
CONTINUAL ASSESSMENT 1 2017
PRIMARY SIX
SCIENCE

Name : _____ ()

Class : Primary 6 / _____

| | |
|-------|--|
| MARKS | |
| 44 | |

Section B: (44 marks)

Write your answers to questions 29 to 41.

The number of marks available is shown in brackets [] at the end of each question or part question.

29. Inhaled air is the air we breathe in from the surroundings and exhaled air is the air that we breathe out. The graphs below show the amount of four gases, W, X, Y and Z, in the air that is inhaled and exhaled.

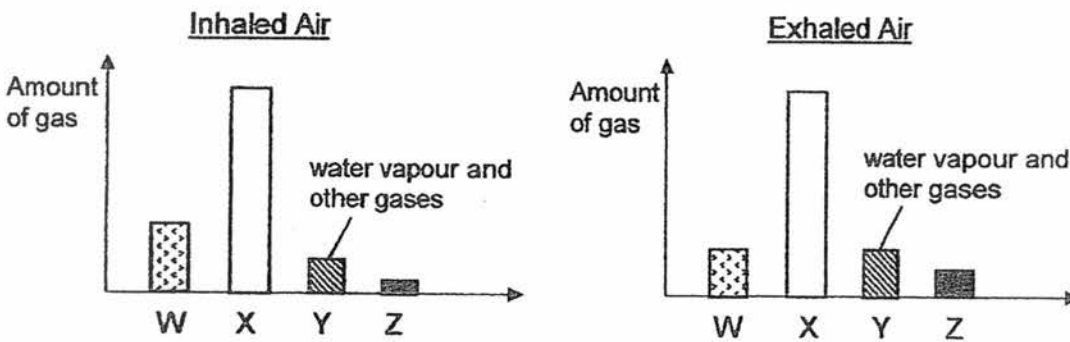

- (a) The amount of gas Z increased in the exhaled air as compared to the inhaled air. What is gas Z? [1]

- (b) In the exhaled air, gas W is the only gas that decreased in amount as compared to the inhaled air. What is gas W and why did it decrease? [2]

| | |
|-------|---|
| Score | 3 |
|-------|---|

30. Francis used a beaker and collected some water from pond D. He shone a torch at the beaker of water and used a light sensor to measure the amount of light that passed through it as shown in the diagram below.

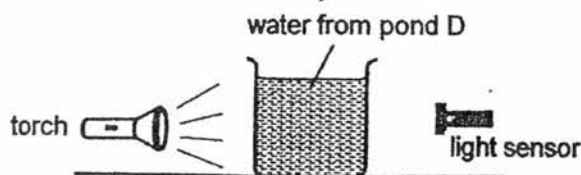

Francis repeated the experiment with water taken from ponds E and F and recorded the results in the table below.

| Pond water | Amount of light (lux) |
|------------|-----------------------|
| D | 5000 |
| E | 900 |
| F | 10000 |

- (a) Based on the table above, which pond has the clearest water? Give a reason for your answer.

[1]

Francis then conducted another experiment using the following set-ups and water from ponds D, E and F. He left the set-ups in a dark room for 12 hours. Except for the type of pond water, all other conditions of the three set-ups were similar.

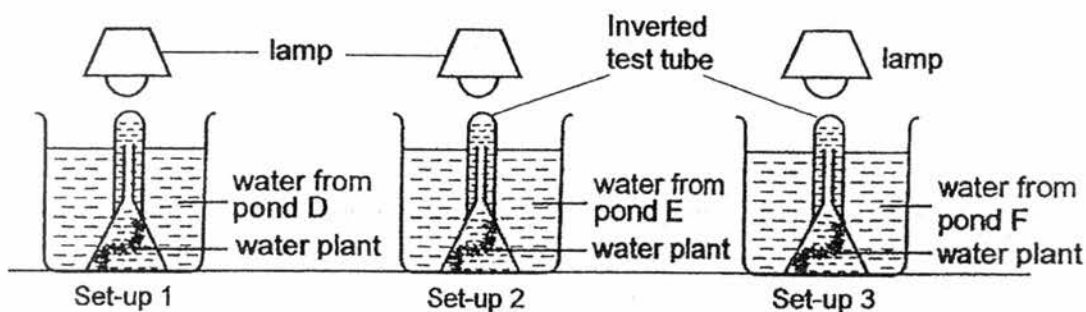

- (b) Which water plant will photosynthesise the least? Explain your answer. [2]

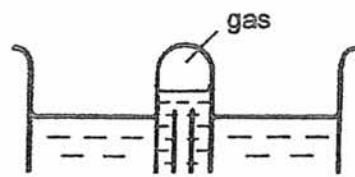

(c) At the end of the experiment, some gas was collected in each of the inverted test-tubes.

i) What is this gas? [1]

ii) Explain this observation. [1]

| | |
|-------|---|
| Score | 5 |
|-------|---|

31. A waterwheel is held below a beaker of water. Water is dripping from a hole at the bottom of the plastic beaker.

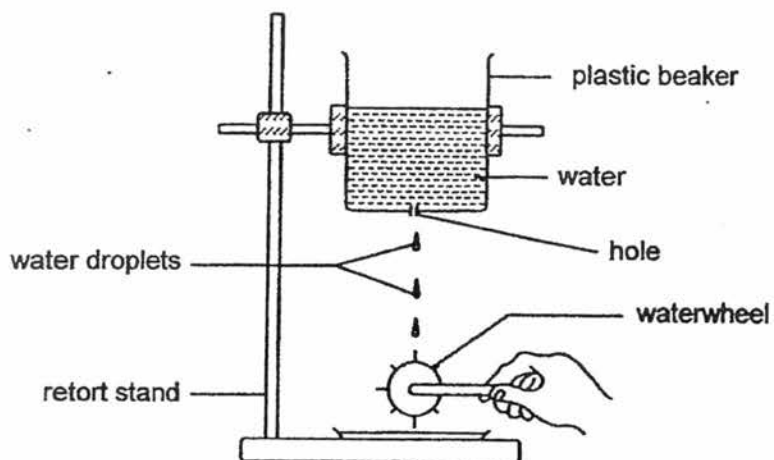

- (a) The waterwheel will spin when the water droplets fall on it. Identify the form(s) of energy possessed by the following: [1]

Water in the plastic beaker: _____

Water droplets: _____

- (b) Without moving or making any changes to the waterwheel, suggest a way to make the waterwheel spin faster. [1]

- (c) Explain your answer in (b) clearly in terms of energy conversion. [2]

| | |
|-------|---|
| Score | 4 |
|-------|---|

32. The diagram below shows a ceiling fan.

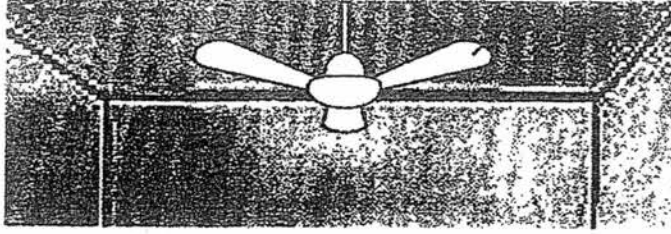

(a) What form(s) of energy do the blades of the ceiling fan possess when the fan is spinning? [1]

(b) After switching off the fan, why did the fan continue spinning for a while before stopping? [1]

(c) Explain in terms of energy why the fan finally stopped spinning after a short while? [1]

| | |
|-------|---|
| Score | 3 |
|-------|---|

33. Jeanie attended an art lesson that required her to draw with a pencil.

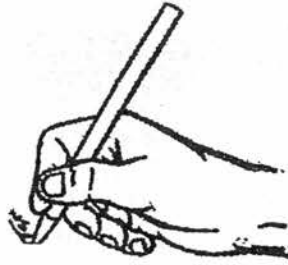

(a) What is the effect of the force exerted on the pencil when she started drawing? [1]

(b) Jeanie made sure she sharpened her pencil before she started drawing. However, after some time, the pencil lead became shorter and blunt. Explain this observation clearly. [2]

| | |
|-------|---|
| Score | 3 |
|-------|---|

34. The diagram below shows a satellite revolving around the Earth.

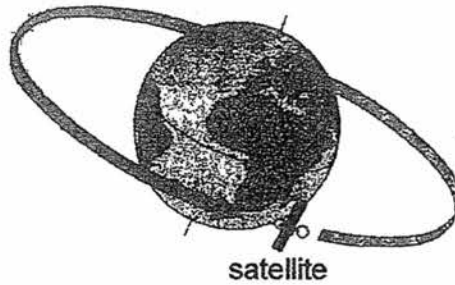

- (a) What is the force that enables the satellite to keep moving around the Earth without spinning away into deep space? [1]

The diagram below shows a lever. A lever is a simple machine that makes doing a task easier. By pushing downwards on one side, an object can be lifted on the other side.

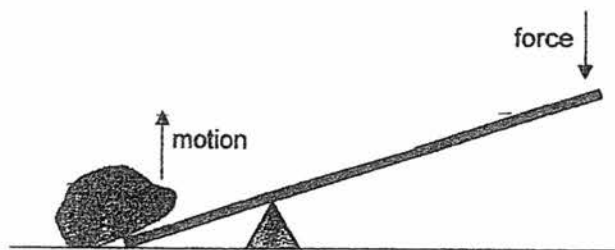

The diagram below shows a man trying to lift a rock.

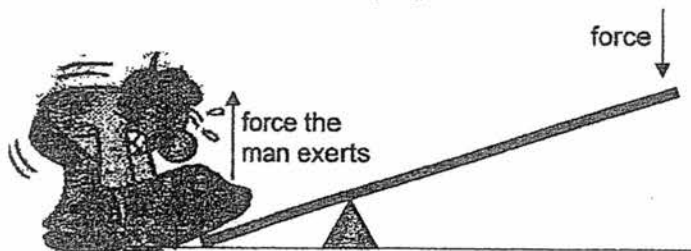

- (b) Why is lifting the rock directly more difficult than lifting it with the help of a lever? [2]

| | |
|-------|---|
| Score | 3 |
|-------|---|

35. Josh made a fan with some recycled materials. He inserted a wooden stick into a straw with a plastic fan attached to it. A thread with a 20 g block attached to it is coiled round the straw as shown in the diagram below. He released the 20 g block and counted the number of cycles the fan spun in 10 seconds.

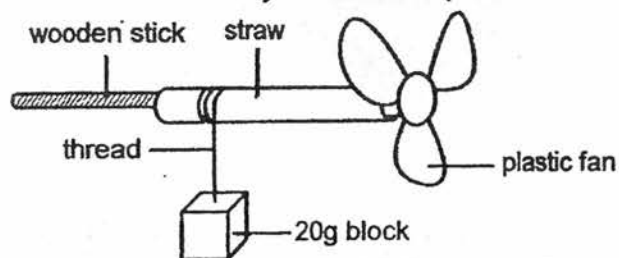

- (a) Fill in the boxes to show the energy changes that enabled the fan to spin. [2]

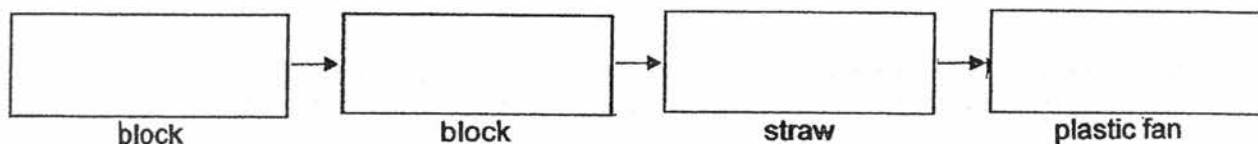

Josh repeated the activity above with blocks of different masses and recorded his findings in the table below.

| Mass of block (g) | Number of cycles the fan spun in 10 seconds |
|-------------------|---|
| 20 | 15 |
| 30 | 25 |
| 40 | 35 |

- (b) Explain clearly how the mass of the block affected the number of cycles the fan spun in 10 seconds. [2]

| | |
|-------|---|
| Score | 4 |
|-------|---|

36. Tom takes the MRT train home after school every day. He enjoys the cool air when he enters the air-conditioned train after walking in the hot sun.

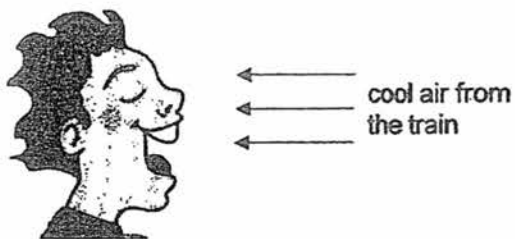

- (a) Explain why he feels cool when he entered the air-conditioned train?

[1]

- (b) One day, Tom got caught in a rain and his uniform was wet. He entered the train as usual, but instead of feeling nice and cool, he felt extremely cold. Explain why he felt much colder this time?

[2]

| | |
|-------|---|
| Score | 3 |
|-------|---|

37. Mavis rolled a rubber ball down a ramp as shown in the diagram below. The rubber ball would then push a toy car at the bottom of the ramp over a surface, W.

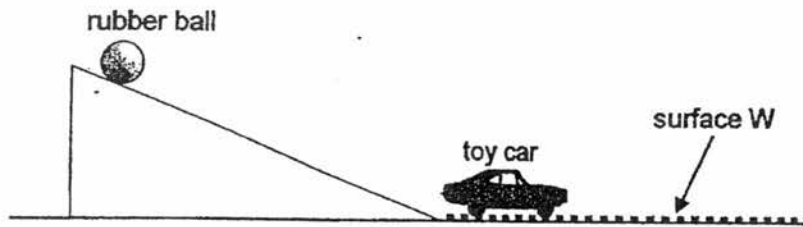

The experiment was repeated using three other surfaces, X, Y and Z. The distance moved by the toy car was recorded in the table below.

| Surface | Distance moved by the toy car (cm) |
|---------|------------------------------------|
| W | 80 |
| X | 120 |
| Y | 40 |
| Z | 60 |

- (a) Mavis used the same toy car, rubber ball and ramp in her experiment. She also made sure that she released the rubber ball without pushing it. State another factor that she must keep constant to ensure a fair test. [1]

- (b) What should she do to improve the reliability of her results? [1]

- (c) Which surface is the smoothest? Explain your answer. [2]

38. In an experiment, 20 g loads were added one at a time to a tray hung on a spring, as shown below. The mass of the empty tray is 5 g.

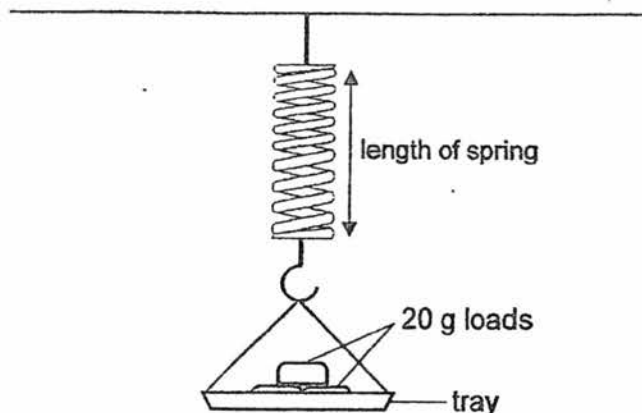

The results are shown in the graph below.

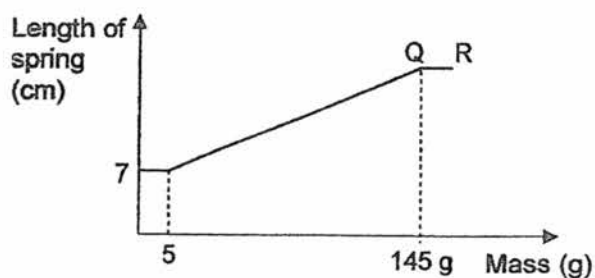

- (a) Why did the spring stretch when the 20 g loads were added to the tray? [1]

- (b) From the graph, why did the length of the spring remain at 7 cm even though the tray was hung onto it? [1]

- (c) From Q to R in the graph, the spring stopped stretching even though more 20 g loads were added. Explain why? [1]

| | |
|-------|---|
| Score | 3 |
|-------|---|

39. Mr Soo prepared an experiment as shown in the diagram below. He placed a strong magnet, X, onto a piece of glass pane clamped to a retort stand. He could change the distance, h , by moving the glass pane clamped to the retort stand up and down.

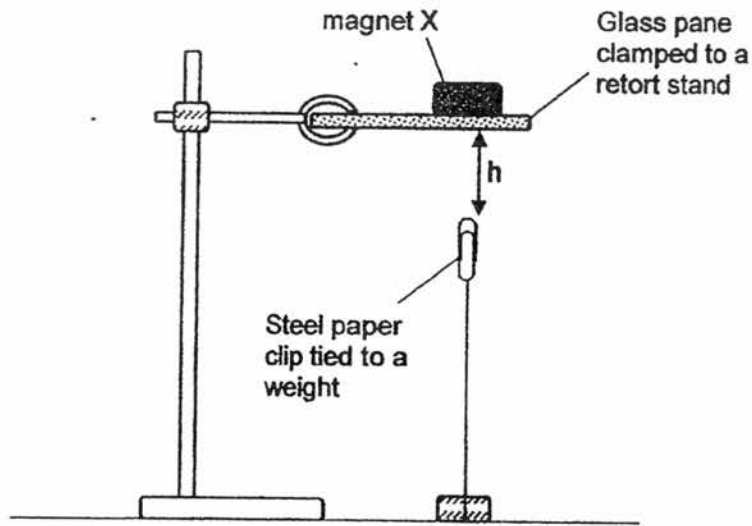

- (a) State two properties of the magnetic force observed in this experiment. [2]

Mr Soo moved the glass panel with the magnet upwards, further away from the paper clip, until the paper clip could no longer be attracted by the magnet and fell to the table. He then recorded the distance, h .

He repeated the experiment with two other magnets, Y and Z, and recorded his results in the table below.

| Magnet | Distance, h (cm) |
|--------|--------------------|
| X | 5 |
| Y | 3 |
| Z | 7 |

- (b) What does distance, h , tell you about the strength of the magnets? [1]



- (c) Mr Soo had a fish bowl on his desk. He accidentally dropped a paper clip into it. The mouth of the bowl was too small for anyone to reach into the bowl. He was also careful not to pour out everything from the bowl and cause the fish to be stressed.

Describe what Mr Soo should do to remove the paper clip using a magnet? [2]

| | |
|-------|---|
| Score | 5 |
|-------|---|

40. Amos set up a circuit as shown in the diagram below for an experiment.

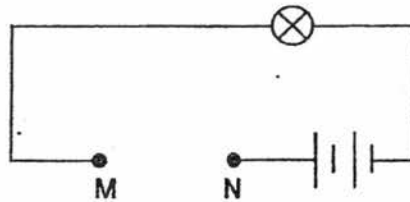

During the experiment, he connected wires of various thickness to points M and N, and measured the brightness of the bulb. He drew a graph with the results he recorded.

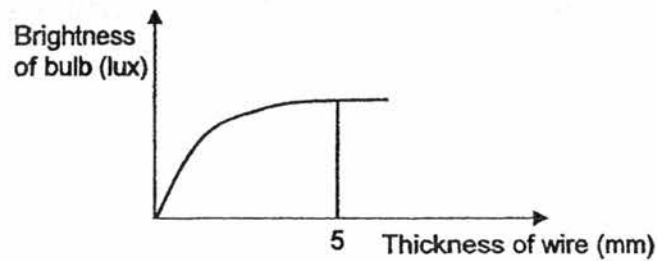

(a) From the graph, how does the thickness of a wire affect the brightness of the bulb? [1]

(b) He should not use the same battery for the whole experiment. Explain how this will help to ensure a fair test. [1]

| | |
|-------|---|
| Score | 2 |
|-------|---|

41. The diagram below shows a fern growing high up from cracks in a brick wall on a building.



- (a) Explain how the characteristics of spores allowed the fern to get to this place? [1]

- (b) How does this method of dispersal help to increase the chance of survival of the seedlings? [1]

End of Paper

| | |
|-------|---|
| Score | 2 |
|-------|---|

YEAR : 2017
LEVEL : PRIMARY 6
SCHOOL : NAN HUA PRIMARY
SUBJECT : SCIENCE
TERM : CA1

Section A

| | | | | | | |
|-----|-----|-----|-----|-----|-----|-----|
| Q1 | Q2 | Q3 | Q4 | Q5 | Q6 | Q7 |
| 4 | 4 | 3 | 1 | 2 | 2 | 2 |
| Q8 | Q9 | Q10 | Q11 | Q12 | Q13 | Q14 |
| 4 | 2 | 2 | 2 | 1 | 4 | 4 |
| Q15 | Q16 | Q17 | Q18 | Q19 | Q20 | Q21 |
| 4 | 1 | 2 | 3 | 2 | 3 | 1 |
| Q22 | Q23 | Q24 | Q25 | Q26 | Q27 | Q28 |
| 3 | 3 | 1 | 4 | 3 | 3 | 3 |

Section B

- Q29 (a) Gas Z is carbon dioxide.
- (b) Gas W is oxygen, it decreased because the body needed to use it, unlike the other gases which were not needed by the body.
- Q30 (a) Pond F, the most amount of light could pass through Pond F compared to the other pond's waters thus it has the clearest water.
- (b) The water plant in set-up 2, pond water E is used in set-up 2 and pond water E had the least light passing through it compared to the other pond waters, so it would block the most light from the lamp and prevent the water plant from getting much light thus the water plant from set-up 2 would photosynthesise the least.

- (c) (i) It is oxygen.
- (ii) The plants would photosynthesise and the by-product of photosynthesis is oxygen, so oxygen would be collected in each of the inverted test tubes.

Q31 (a) (i) Water in the plastic beaker: Gravitational potential energy.

Water droplets: Kinetic energy and gravitational potential energy.

- (b) Place the plastic beaker of water higher up.
- (c) The water droplets falling from a higher height which has more gravitational potential energy is converted to more kinetic energy in the water and transferred to more kinetic energy in the waterwheel.

Q32 (a) Gravitational potential energy and kinetic energy.

- (b) It is because not all the kinetic energy has been converted to sound and heat energy yet.
- (c) After a short while, all the kinetic energy of the fan was converted to sound and heat energy and the fan no longer possessed any kinetic energy to spin.

Q33 (a) It moved the stationary pencil.

- (b) The frictional force between the pencil lead and the drawing surface had smoothed the pencil lead as frictional force causes wear and tear.

Q34 (a) Gravitational force.

- (b) The man lifting the rock directly has to work against gravity but using the lever helps him to work in the same direction as gravity.

Q35 (a)

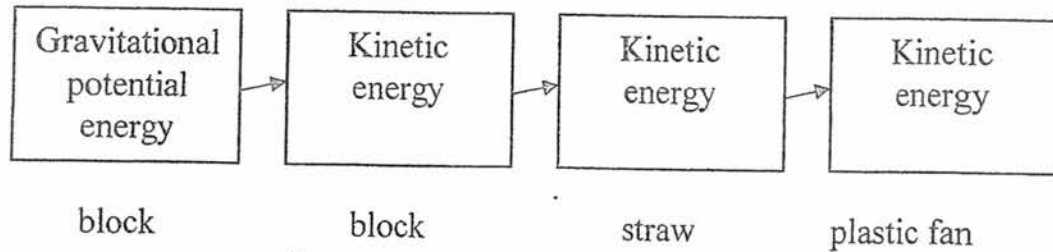

- (b) As the mass of the block increases, the gravitational potential energy of the block would also increase and when released, more gravitational potential energy would be converted to more kinetic energy of the block and more kinetic energy of the block would be transferred to the straw and finally to the plastic fan, which would cause the fan to spin more cycles in 10 seconds.

Q36 (a) Tom's body would lose heat to the cooler air from the train.

(b) Tom's body lost more heat as the water in his clothes gained heat from his body to evaporate.

Q37 (a) The place the toy car is placed on each surface should be constant.

(b) Mavis should repeat the experiment a few times and calculate the average results.

(c) Surface X is the smoothest, this is because the toy car could travel the greatest distance compared to when on the other surfaces and it had the least friction between the toy car and it.

Q38 (a) It is because the weight of the 20g loads pulled the spring downwards and stretched it.

(b) The weight of the tray is not heavy enough to stretch the spring or the weight of the tray was too light.

(c) The spring cannot be stretched anymore.

- Q39 (a) It can act at a distance and can pass through non-magnetic objects.
- (b) Magnet Z is the strongest followed by magnet X and magnet Y.
- (c) Mr Soo should place the magnet at the outer surface of the fish bowl closest to the steel paper clips and when the magnet attracts the paper clips, slowly move the magnet up of the fish bowl and retrieve the steel paper clips.
- Q40 (a) The thicker the wire, the brighter the bulb but when the wire becomes 5mm, then the brightness of the bulb will remain constant.
- (b) The battery will weaken causing the bulb to be less bright.
- Q41 (a) Spores are light and can be carried by wind.
- (b) This ensures that the seedlings grow further away from the parent plant and prevents overcrowding.

End