

Tao Nan School
Primary 6 Science Mid Year Examination - 2008

Name: _____ ()

Date: 8 May 2008

Class: Primary 6 ()

Duration: 1h 45 min

Parent's signature: _____

Marks: _____ /100

Section A (30 X 2 marks)

For each question from 1 to 30, four options are given. Select its correct option and shade its corresponding oval (1, 2, 3, 4) on the Optical Answer Sheet.

1. The diagram below shows a plant cell.

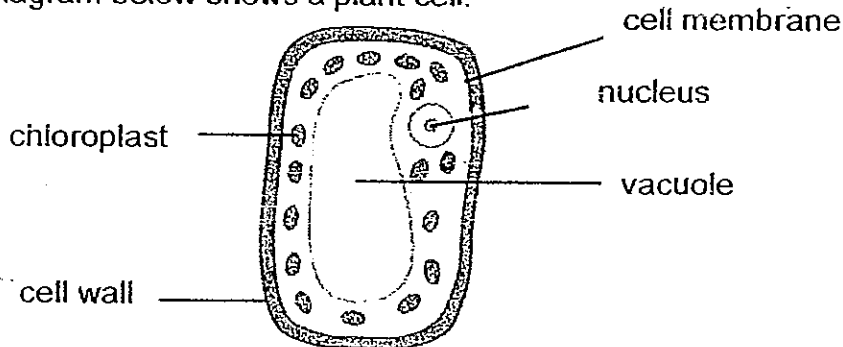

At which plant part is the above cell found ?

- (1) Lotus Root
 - (2) Leaf Blade
 - (3) Tree Bark
 - (4) Rubber Seed
2. Which parts of a cell are found in animals and plants?
- A Nucleus
 - B Cytoplasm
 - C Cell wall
 - D Cell membrane
- (1) A and C only
 - (2) B and D only
 - (3) A, B and D only
 - (4) B, C and D only

3. Study the classification chart below and match the parts of the body to the correct body systems, A, B and C.

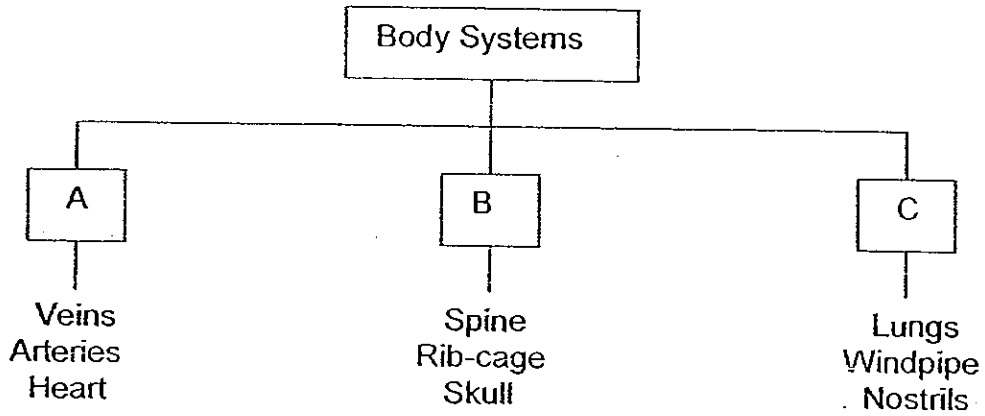

	A	B	C
(1)	Circulatory	Respiratory	Skeletal
(2)	Respiratory	Skeletal	Circulatory
(3)	Circulatory	Skeletal	Respiratory
(4)	Skeletal	Circulatory	Respiratory

4. The diagram below shows E, F, G and H, the four stages in the life cycle of a moth and when fertilisation occurs.

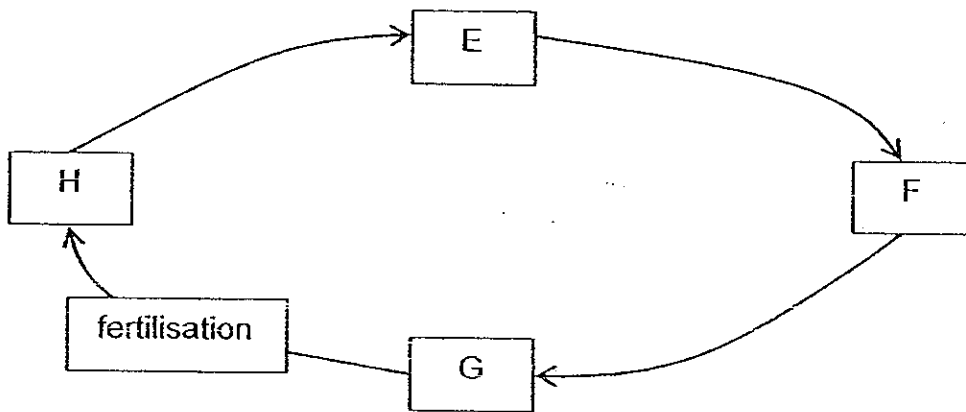

Which of the following shows the stages of its life cycle ?

	E	F	G	H
(1)	Egg	Larva	Pupa	Adult
(2)	Larva	Pupa	Adult	Egg
(3)	Pupa	Adult	Egg	Larva
(4)	Adult	Egg	Larva	Pupa

5. A plant with two white flowers, X and Y, was placed into a beaker filled with red-coloured water as shown in the diagram below. After two hours, X turned red while Y remained white. Two cuts, 1 and 2, were immediately made at two sections of the stem.

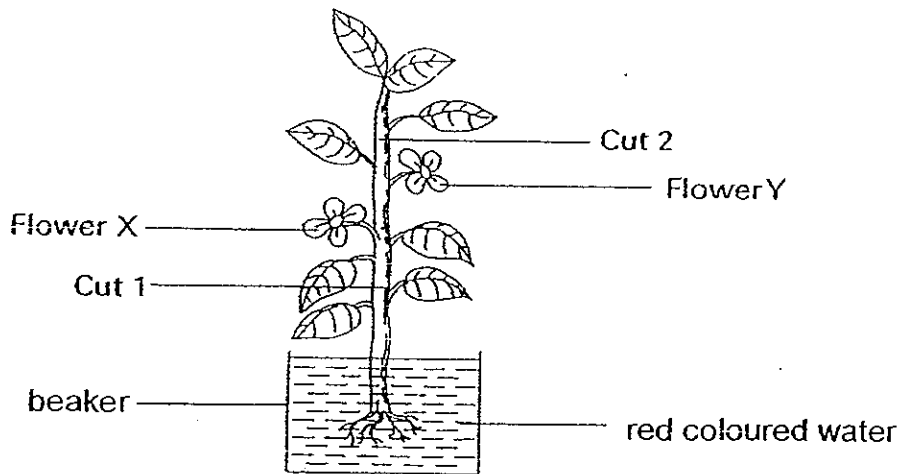

Which of the following shows the cross-sections of the stems at the cuts, 1 and 2 ?

- (1) Cut 1 Cut 2
- (2) Cut 1 Cut 2
- (3) Cut 1 Cut 2
- (4) Cut 1 Cut 2

Key	
	red-coloured
	not coloured

6. Three plants, P, Q and R are found along a river bank as shown in Figure 1 below.

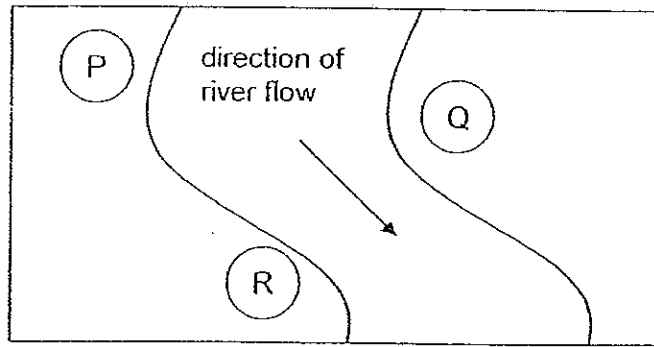
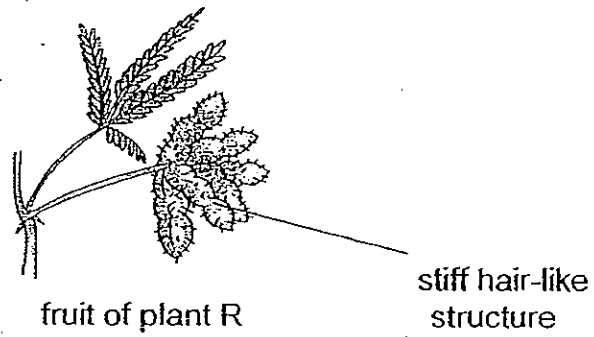
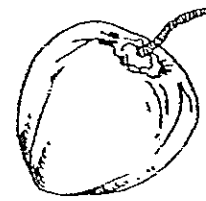
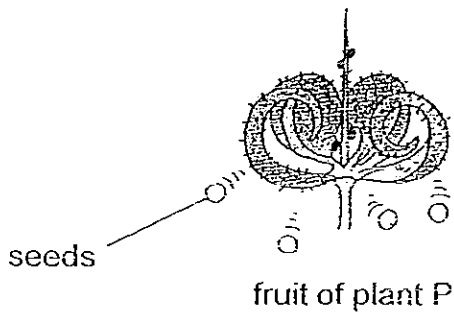

Figure 1

The fruits of the plants, P, Q and R, are shown below.



Which of the following diagrams shows the location of the young plants in relation to their parent plants a year later?

(1)

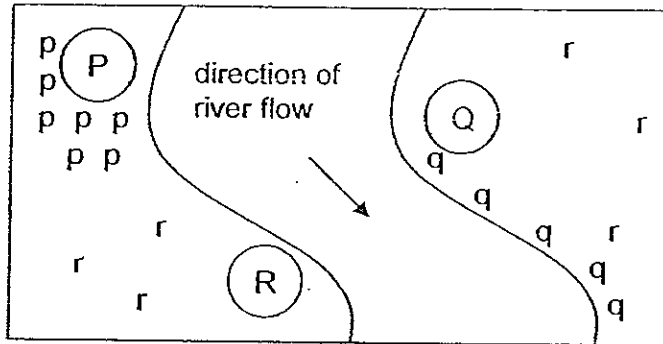

(2)

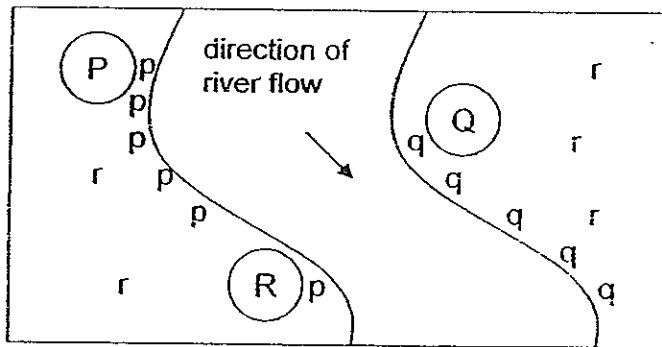

(3)

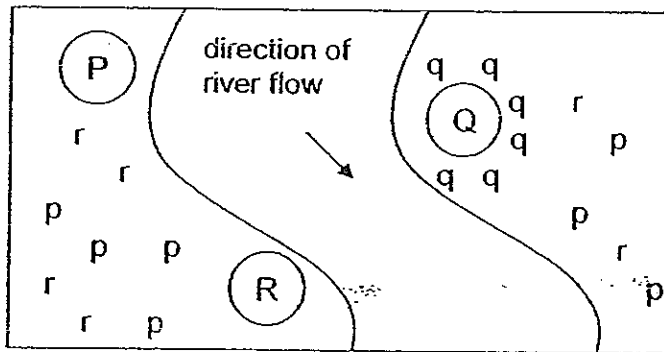

(4)

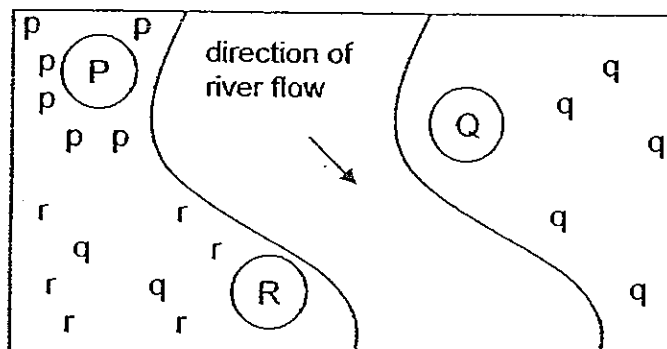

7. Study the classification chart below.

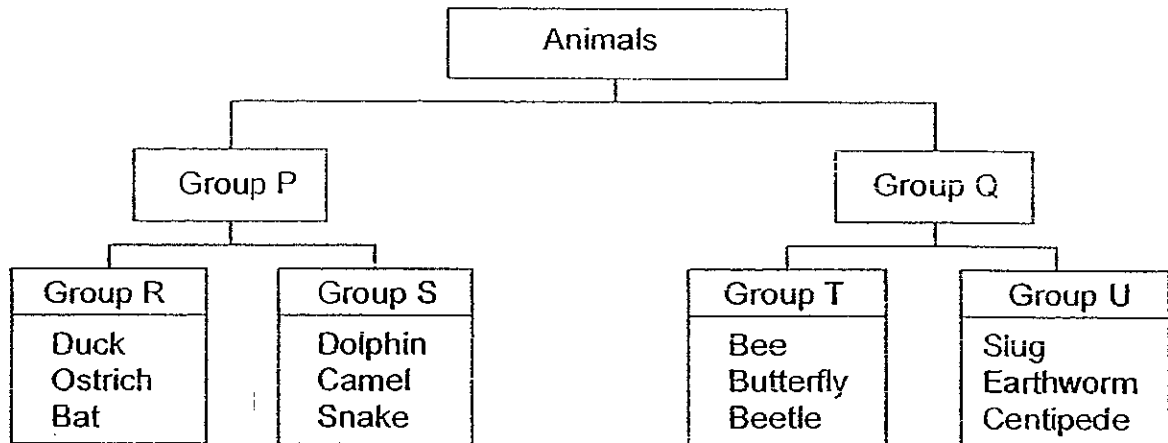

Which of the following are correct ?

- A Animals in Group R have wings while animals in Group S have hair.
 - B Animals in Group T have wings while animals in Group U have no wings.
 - C Animals in Group P have backbones while animals in Group Q have no backbones.
- (1) C only
 (2) A and B only
 (3) B and C only
 (4) A, B and C

8. Eugene wanted to find out how the size of pots affect plant growth. He planted 3 similar balsam plants in three pots, X, Y and Z. The three plants were placed in the garden as shown below.

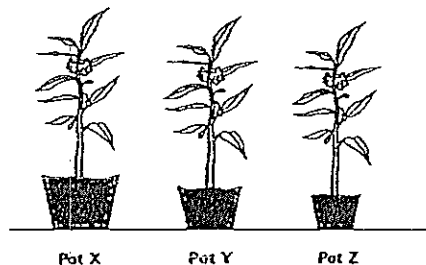

Eugene drew a table about his experiment below.

	Pot X	Pot Y	Pot Z
Size of pot	Large	Medium	Small
Amount of water given to the plants daily (cm ³)	150	150	150
Type of water used	Tap water	Rain water	Pond water
Type of soil	Garden soil	Garden soil	Garden soil

Why was the experiment **not** a fair one ?

- (1) The size of pots used in each pot was different.
- (2) The type of water given to the plants was different.
- (3) The three pots were given the same amount of water.
- (4) The balsam plant in Pot Y obtained more sunlight than the others.

9. Justin grew 2 plants in set-up A and set-up B as shown below.

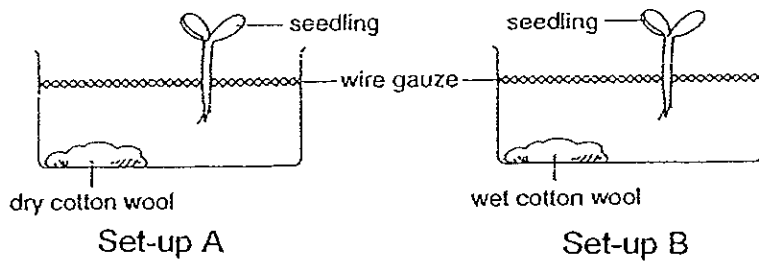

Three days later, Justin observed a change in both set-ups as shown below.

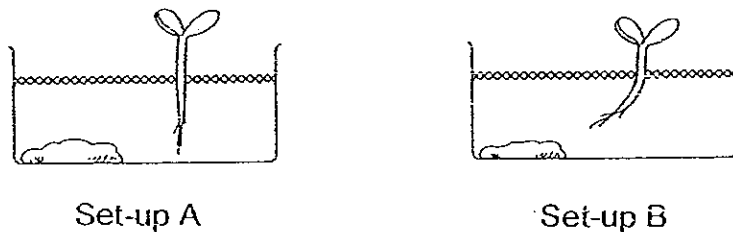

From his observations, what can he conclude about plant growth?

- (1) Roots grow towards water
 - (2) Plants need oxygen to grow
 - (3) Leaves grow towards sunlight
 - (4) Plants need carbon dioxide to grow
10. Which two animals have life cycles that are very similar to the life cycle of a grasshopper ?
- (1) Cricket and Cockroach
 - (2) Housefly and Mealworm beetle
 - (3) Moth and Butterfly
 - (4) Chicken and Dog

11. Study the flow chart below.

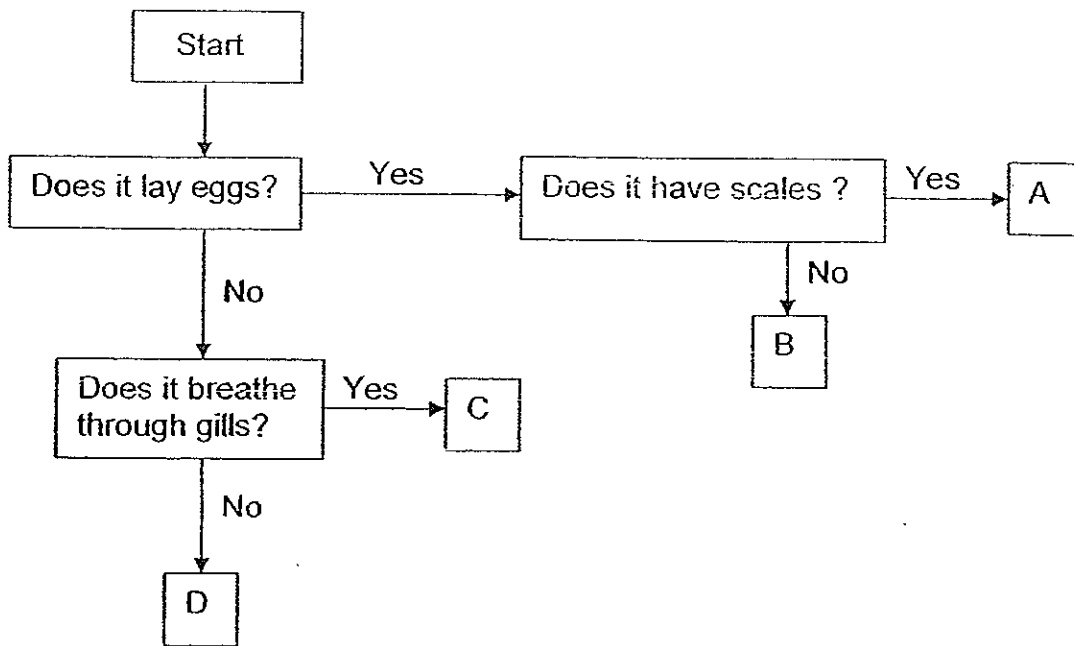

Which of the following are A, B, C and D ?

	A	B	C	D
(1)	Snake	Spiny anteater	Swordtail	Tilapia
(2)	Spiny anteater	Guppy	Camel	Ant
(3)	Tortoise	Platypus	Guppy	Monkey
(4)	Prawn	Tilapia	Crab	Camel

12. Look at the diagram below carefully.

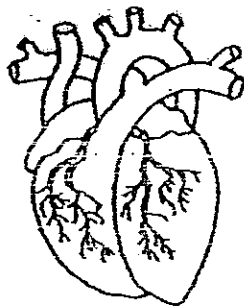

Name the part of the skeletal system which protects the organ above.

- (1) skull
- (2) spine
- (3) rib cage
- (4) hip bone

13. Simon set up an experiment to find out how the material of a cup holder affects the temperature of water. Simon heated the water in a cup holder made of material A with a large candle flame over 30 minutes. He recorded the temperature change of the water. Then he repeated the experiment with another cup holder made of material B.

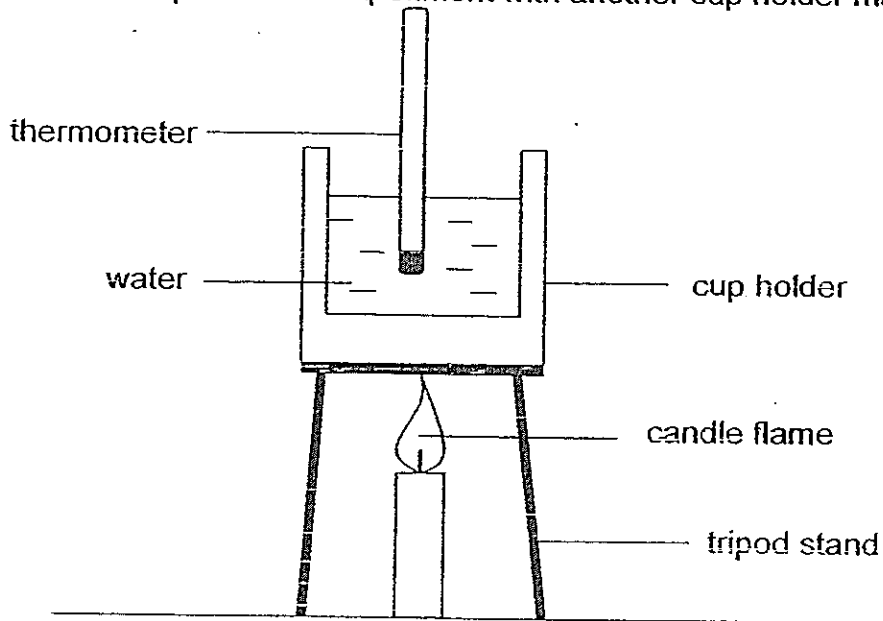

The following graph shows how the temperature changed over 30 minutes.

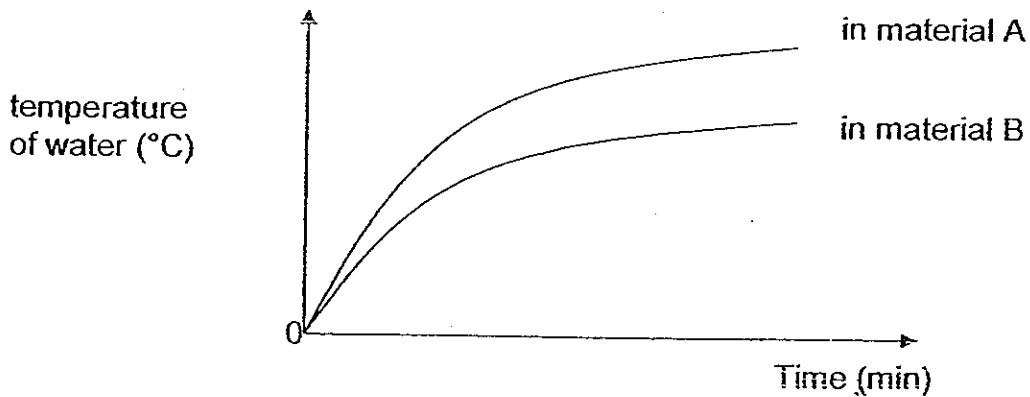

Which of the following is definitely true ?

- (1) Material A is black while material B is white.
- (2) Material A is a better conductor of heat than material B.
- (3) Material A is a poorer conductor of heat than material B.
- (4) Material A is a conductor of electricity while material B is an insulator of electricity.

14. Kim Siong classified the force in some actions as a pull or a push. Which actions have been classified **wrongly** ?

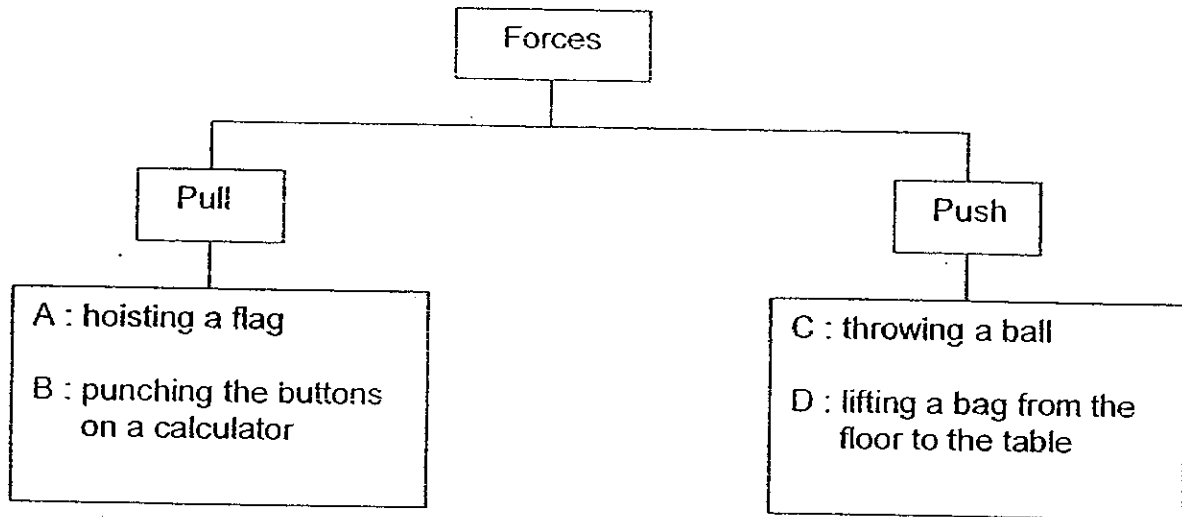

- (1) A and C only
- (2) A and D only
- (3) B and C only
- (4) B and D only

15. The drawings below show four examples of how forces are used.



A : climbing up a cliff B : running on the ground C : opening a bottle D : catching a ball

In which examples is **friction** useful ?

- (1) A and D only
- (2) B and C only
- (3) A, C and D only
- (4) A, B, C and D

16. A bowl contained 400g of water. A 30g cube of sugar was placed in the bowl of water and stirred until it dissolved completely.

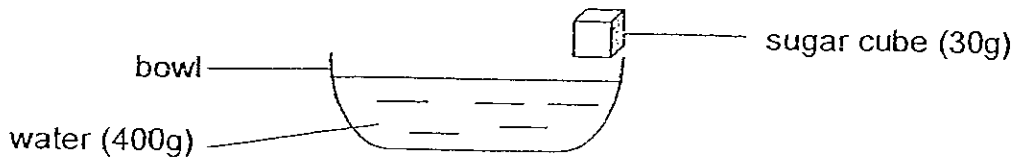

After one day, it was found that only 420g of the solution was left in the bowl.

What would the remaining solution contain?

- (1) 420g of sugar
 - (2) 420g of water
 - (3) 390g of water and 30g of sugar
 - (4) 400g of water and 20g of sugar
17. A group of students set up an experiment to find out the effect of the Sun's heat on cups of various colours. The students made four cups using the same type of paper but of different colours. They left the four cups in a sunny place for 4 hours. The graph below shows the temperature in each cup at different times.

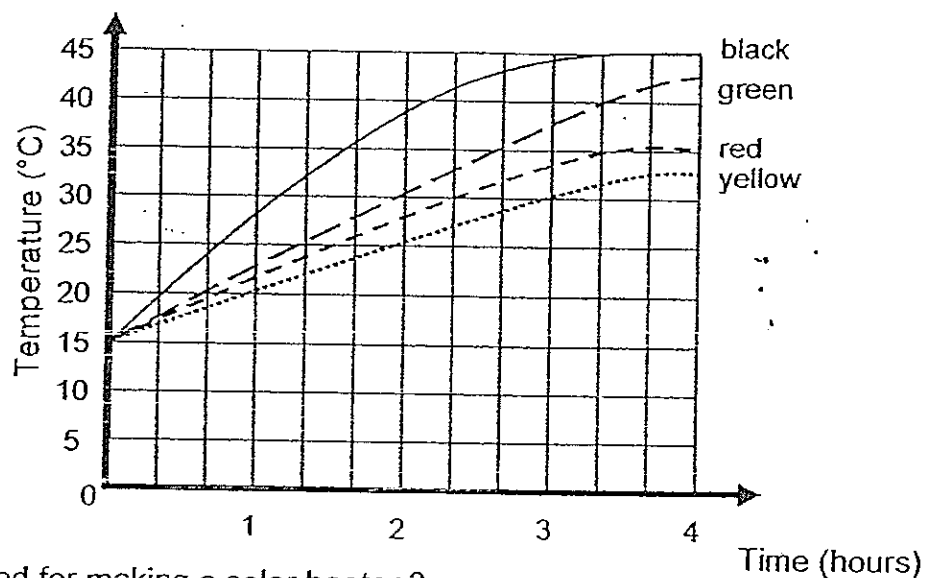
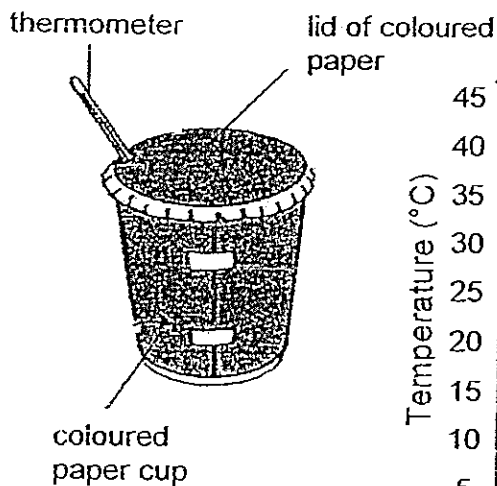

Which colour is best suited for making a solar heater ?

- (1) Black
- (2) Green
- (3) Red
- (4) Yellow

18. The diagram below shows a hydroelectric power station.

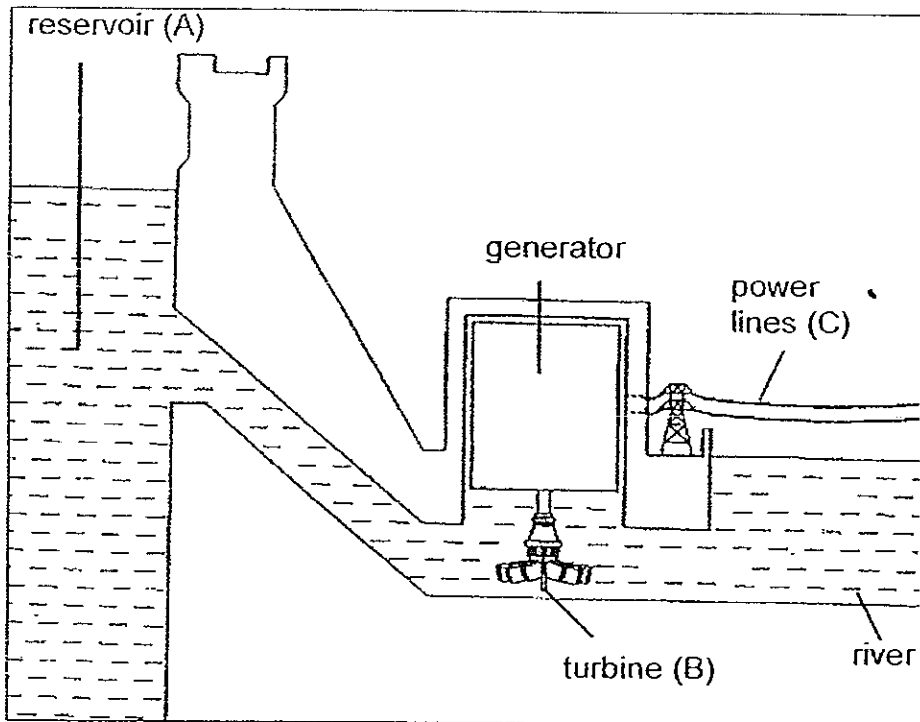

Identify the correct forms of energy at the different stages, A, B and C.

Forms of energy at the different stages			
	A	B	C
(1)	Potential Energy	Kinetic Energy	Electrical Energy
(2)	Potential Energy	Electrical Energy	Electrical Energy
(3)	Potential Energy	Kinetic Energy	Potential Energy
(4)	Kinetic Energy	Kinetic Energy	Electrical Energy

19. Where does a mango tree obtain its energy from?

- (1) Sun
- (2) Oxygen
- (3) Animals
- (4) Decomposers

20. A ball which was tied to a string was dropped from point P. The diagram below shows how the ball swung from point P to the other end, point R.

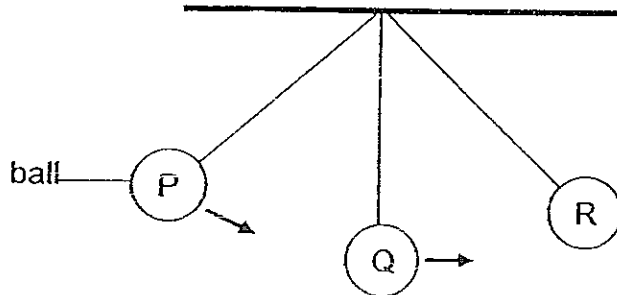

Which of the following identify the forms of energy the ball possess at points P, Q and R?

	Point P	Point Q	Point R
(1)	Maximum gravitational potential energy	Minimum gravitational potential energy and maximum kinetic energy	Minimum kinetic energy
(2)	Maximum kinetic energy	Minimum gravitational potential energy	Maximum gravitational potential energy
(3)	Maximum kinetic energy	Maximum kinetic energy	Maximum gravitational potential energy
(4)	Maximum gravitational potential energy	Maximum gravitational potential energy and minimum kinetic energy	Minimum kinetic energy

21. Study the classification table below.

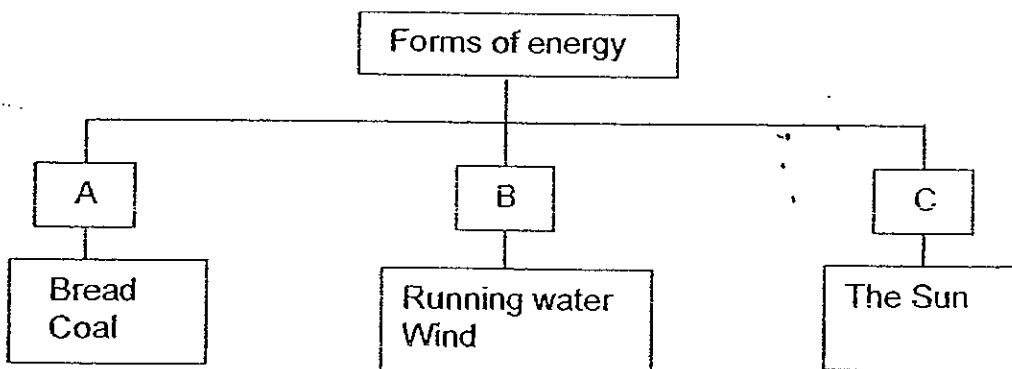

Match A, B and C to the forms of energy they represent.

	A	B	C
(1)	Light energy	Potential energy	Heat energy
(2)	Heat energy	Electrical energy	Light energy
(3)	Potential energy	Sound energy	Electrical energy
(4)	Chemical energy	Kinetic energy	Solar energy

22.

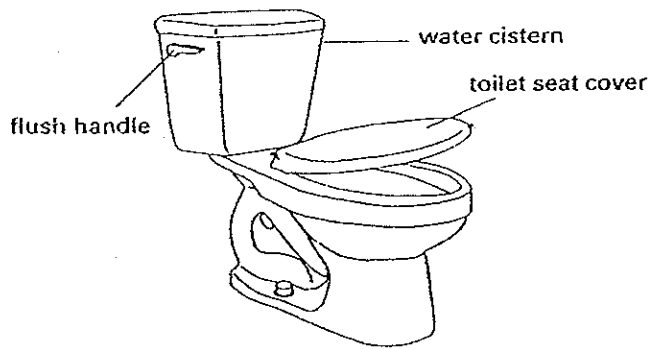

Object A

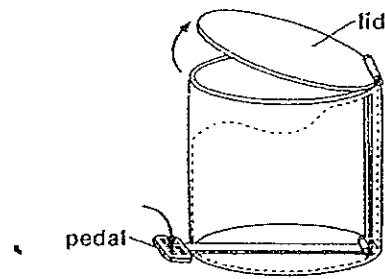

Object B

Which simple machine is used in both objects, A and B?

- (1) Lever
- (2) Gears
- (3) Inclined plane
- (4) Wheel and axle

23. A sponge and two marbles are placed on a balance as shown below. The needle of the balance is at the zero mark.

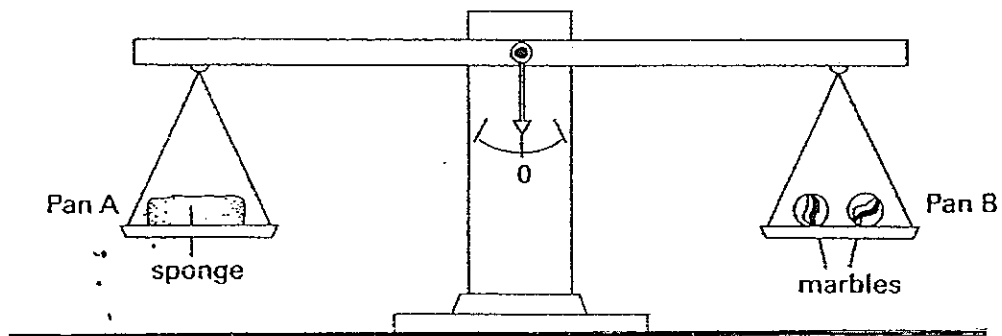

Which of the following is true ?

- (1) The sponge and the marbles have no mass.
- (2) The sponge and the marbles are pulled by gravity.
- (3) The sponge occupies the same space as the marbles.
- (4) The mass of the sponge is equal to the mass of **one** marble.

24. 3 objects, D, E and F are brought very near to the N-pole of a hanging magnet as shown below.

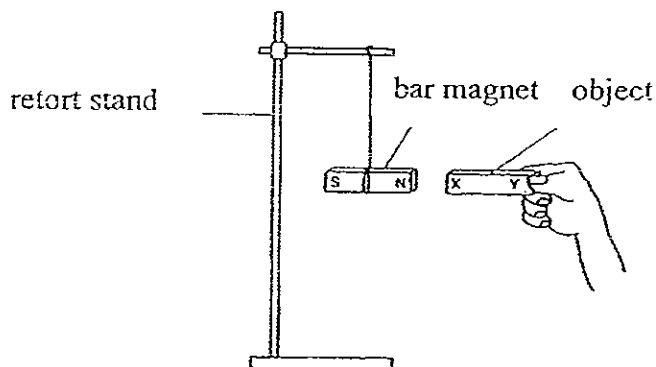

The table below shows the results of the experiment.

Object	End	Attracted to the magnet?	Repelled by the magnet?	No reaction to the magnet?
D	X	No	No	Yes
	Y	No	No	Yes
E	X	Yes	No	No
	Y	Yes	No	No
F	X	No	Yes	No
	Y	Yes	No	No

Which of the following is correct?

- A Object E is a magnet.
- B Object D is made of iron.
- C End X of object E is the N-pole.
- D End Y of object F is the S-pole.

- (1) A only
- (2) D only
- (3) A and C only
- (4) B and D only

25. Study the flow chart below.

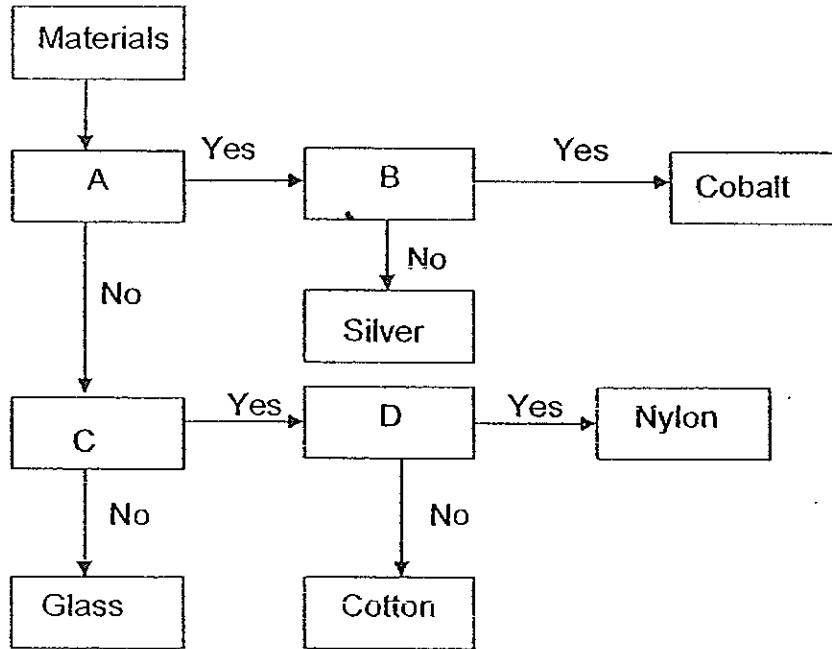

Which of the following are ^{A, B, C and D} ~~A, B and C?~~

	A	B	C	D
(1)	Does it conduct electricity?	Can it be attracted to a magnet?	Is it flexible?	Is it waterproof?
(2)	Is it flexible?	Can it be attracted to a magnet?	Is it hard?	Is it once alive?
(3)	Is it fragile?	Does it allow light to pass through?	Is it flexible?	Is it waterproof?
(4)	Does it allow light to pass through?	Does it conduct electricity?	Is it fragile?	Is it once alive?

26. Adrian had two similar sheets of paper. He crushed one of them into a ball. He then dropped the uncrushed paper and the crushed paper from the same height as shown below.

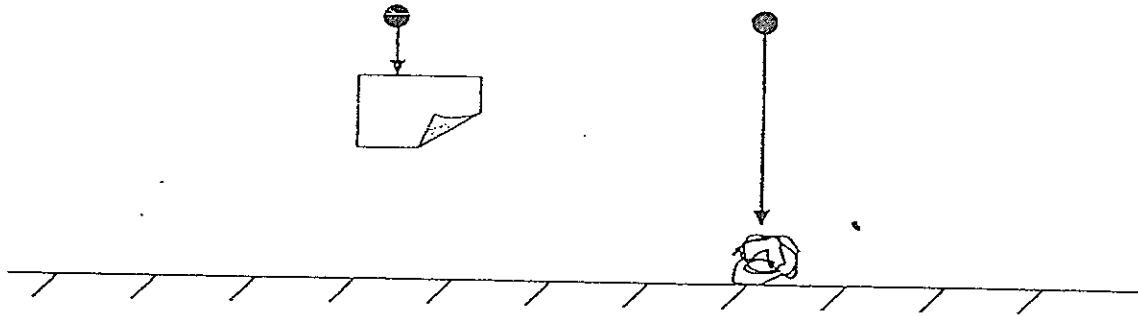

The crushed paper dropped faster than the uncrushed paper. Why?

- (1) The crushed paper has less mass
 - (2) The uncrushed paper has less mass
 - (3) The crushed paper experiences a greater upward push due to air resistance
 - (4) The uncrushed paper experiences a greater upward push due to air resistance
27. A 500g block was dragged along surface A and the average pulling force was recorded.

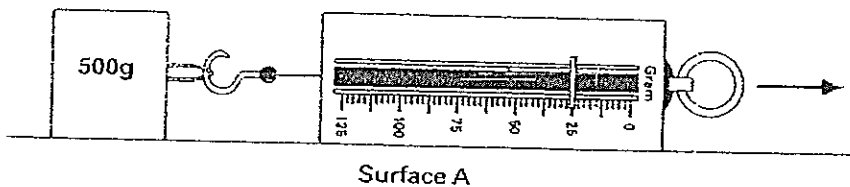

The experiment was repeated by pulling the same block along surfaces B and C. The table below shows the average pulling force along the different surfaces.

Surface	A	B	C
Average pulling force (N)	0.6	0.9	0.3

Which of the following sets of surfaces matches the average pulling forces ?

	A	B	C
(1)	sandpaper	glass	wood
(2)	wood	sandpaper	glass
(3)	glass	wood	sandpaper
(4)	sandpaper	wood	glass

28. The diagram below shows an electric circuit.

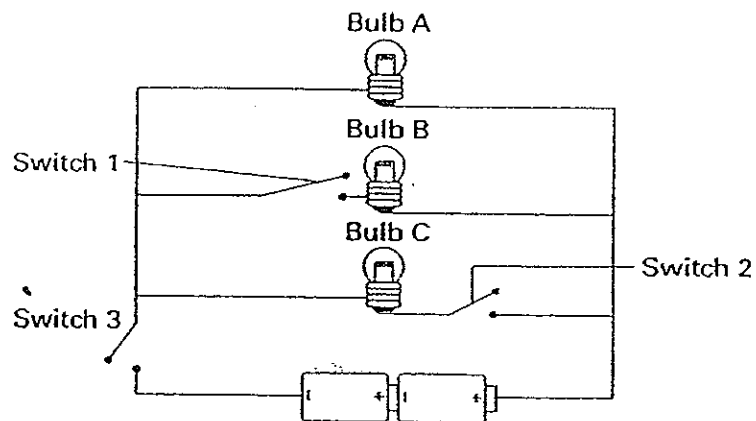

In which order must the switches be closed so that Bulb A lights up first, followed by Bulb B and then Bulb C?

	First switch to close	Second switch to close	Third switch to close
(1)	1	2	3
(2)	3	1	2
(3)	3	2	1
(4)	2	1	3

29. The speed at which a parachute falls depends on various factors.
The diagram below shows a toy parachute which a class of pupils had made.

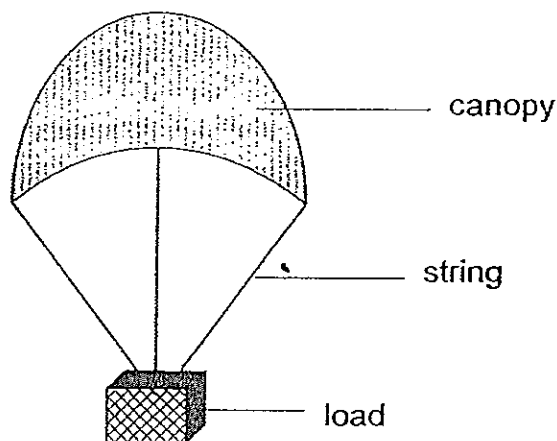

These pupils formed groups to find out the time taken for the parachute to fall from a height of 10m by changing different variables. The results were recorded in the table below.

Experimental set-up	Size of canopy (cm ²)	Mass of load (g)	Material of canopy	Time taken for the parachute to reach the ground (s)
R	625	30	paper	9
S	400	30	cotton	5
T	625	20	cotton	10
U	900	30	paper	10
V	400	10	paper	7
W	625	30	plastic	11
X	900	20	cotton	13
Y	900	10	plastic	11
Z	400	20	cotton	8

Their teacher, Mr Yeo, wanted to find out how the size of the canopy affects the time taken for the parachute to reach the ground. Which **three** experimental set-ups should he choose for this purpose?

- (1) S, V and Z only
- (2) R, U and W only
- (3) U, X and Y only
- (4) T, X and Z only

30. Jillian placed an electromagnet near a magnet and a copper rod as shown below.

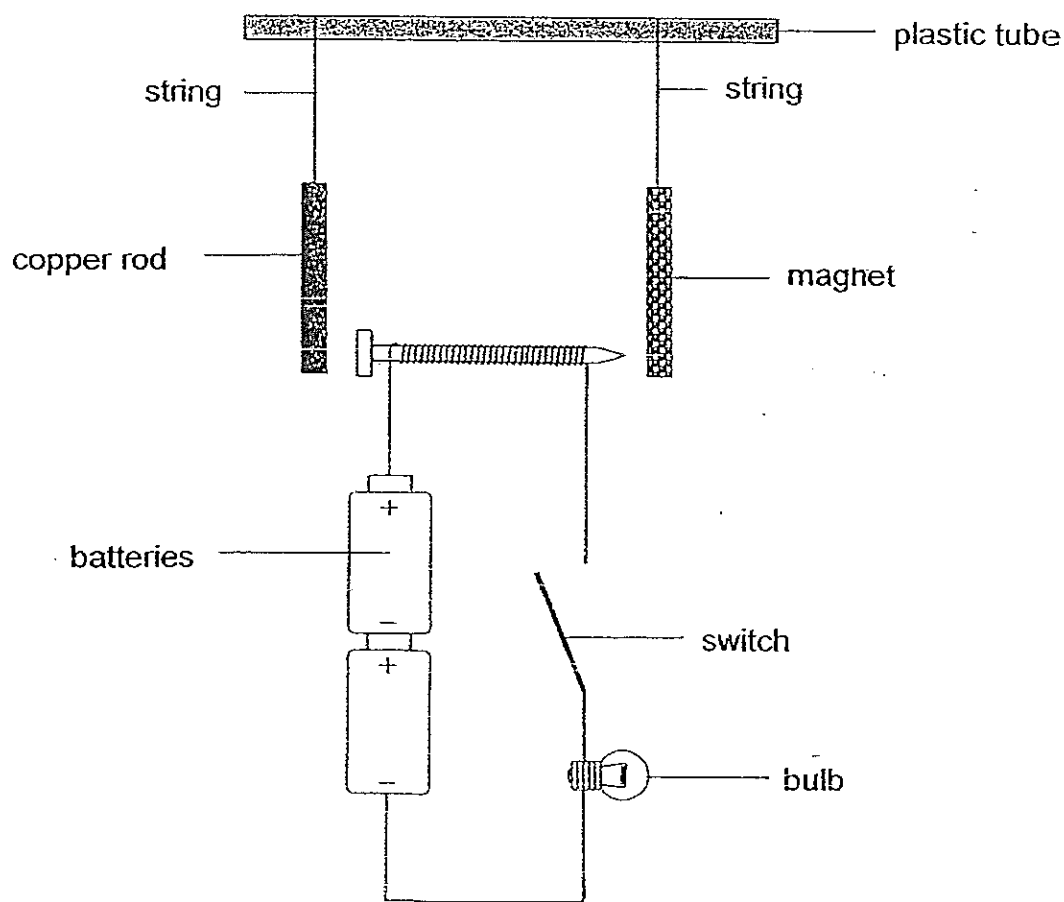

When the switch is closed, which are the most likely observations?

- A The bulb lights up
 - B The magnet moves to the left
 - C The magnet moves to the right
 - D The copper rod remains at the same position
- (1) A and B only
 (2) C and D only
 (3) A, B and C only
 (4) B, C and D only

Name: _____ ()

Marks: _____ /40

Class : Primary 6 _____

Section B (40 marks)

For questions 31 to 46, write your answers in the spaces provided.

31. Complete the classification chart with the following organisms. [3]

balsam plant	grasshopper	staghorn fern
duck	snake	dolphin

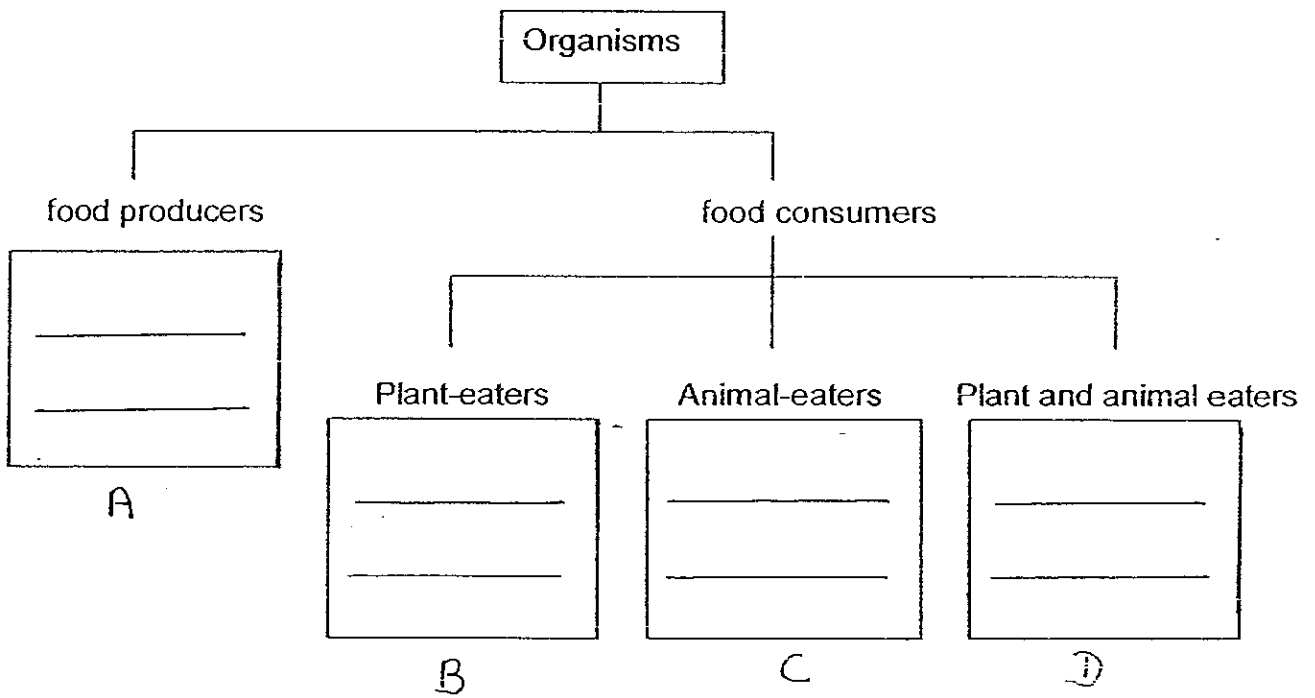

32. Study the statements below and put a tick (✓) in the appropriate box. [2]

	Statement	True	False	Not possible to tell
(a)	The stoma is found only on the leaves of a plant.			
(b)	The stoma consists of one guard cell.			
(c)	The stoma allows exchange of gases during photosynthesis and respiration.			
(d)	The guard cells control the amount of water lost through transpiration.			

33. The diagram below shows the family tree of Mei Yan.

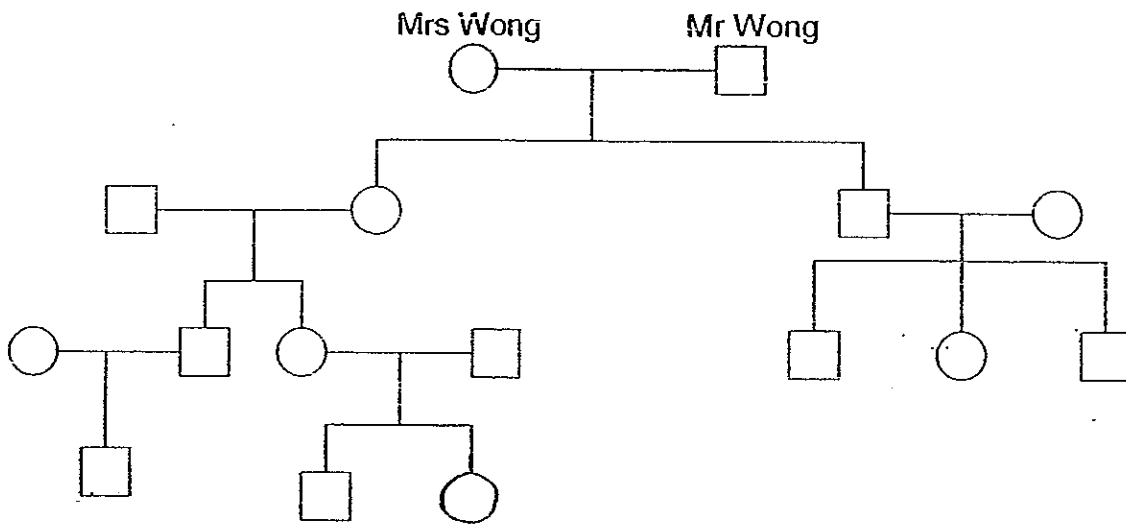

Key

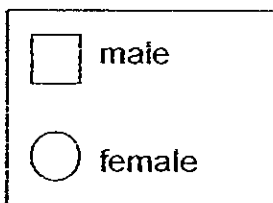

(a) Chee Mei Yan is Mr Wong's great granddaughter.

Identify and shade the or representing Mei Yan in the family tree. [1]

(b) How many cousin(s) does Mei Yan have? [1]

34. The diagram below shows the cross section of a flower.

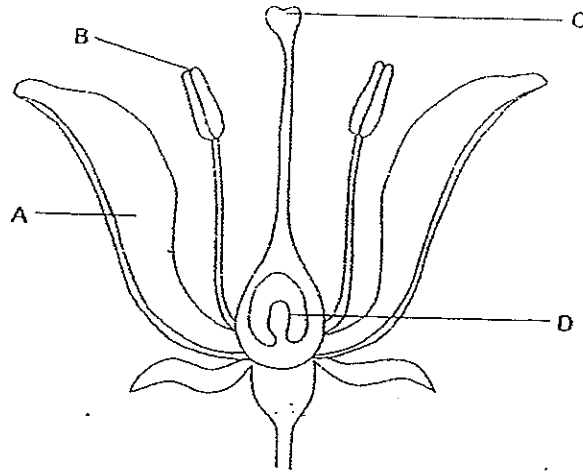

Complete the table below with the reproductive parts of the flower (A, B, C or D) that have similar functions to the reproductive organs of a human being.

[2]

Similarities	
Reproductive organs of a human being	Reproductive parts of a flower
Testes	(a)
Ovary	(b)

35. Bala wanted to find out if Wood A or Wood B is stronger. He added weights onto the centre of Wood A until it broke. He did the same for Wood B.

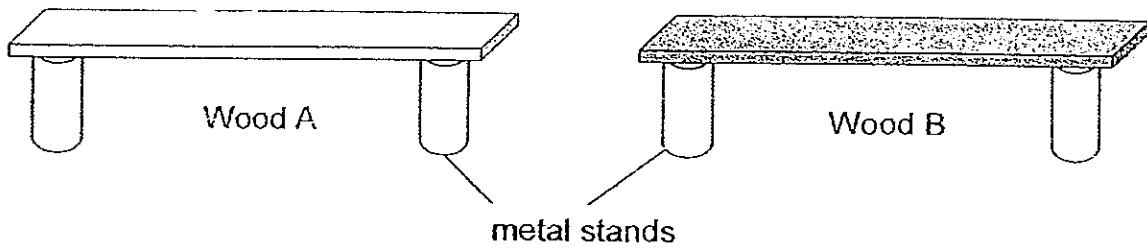

(a) Which variable should he change to ensure a fair test?

[1]

(b) Which 2 variables should he keep the same?

(i) _____

[1]

(ii) _____

[1]

36.

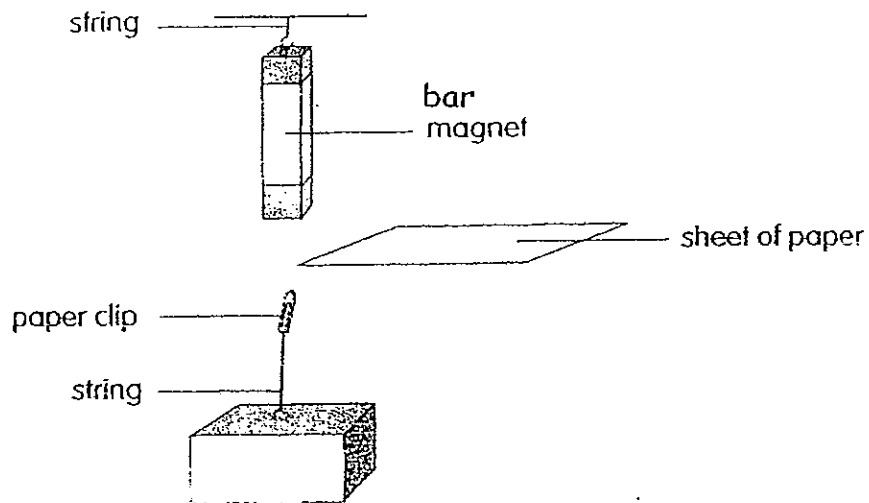

Study the set-up above.

- (a) What will happen to the paper clip when a sheet of paper is placed between the bar magnet and the paper clip? [1]

- (b) What will happen to the paper clip when a sheet of steel is placed between the bar magnet and the paper clip? [1]

- (c) Explain your answer in (b). [1]

37. Salim set up a circuit with a sheet made of material W as shown below.

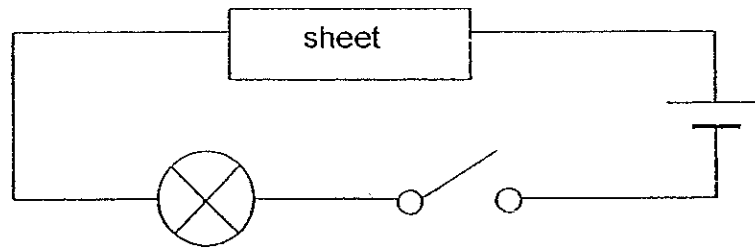

He observed the brightness of the bulb and recorded the results in the table. Then he replaced the sheet made of Material W with sheets made of Materials X, Y and Z. The results are shown in the table below.

Material	Brightness of bulb
W	Bright
X	Very bright
Y	Unlit
Z	Dim

(a) Which material is most suitable for making a lightning conductor? [1]

Material _____.

(b) Which material is most suitable for making a covering for electrical wires? [1]

Material _____.

38. The diagram below shows the length of four similar springs with different loads hung on them.

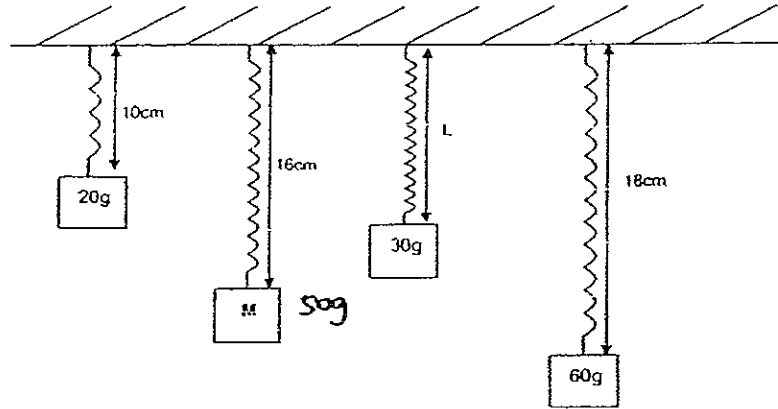

The original length of the spring is 6 cm.

Complete the table below to find the extensions of the springs with different loads hung on them. [2]

Mass (g)	Initial length (cm)	Final length (cm)	Extension (cm)
0			
20			
30			
60			

Use the data to construct a line graph in the grid below. [2]

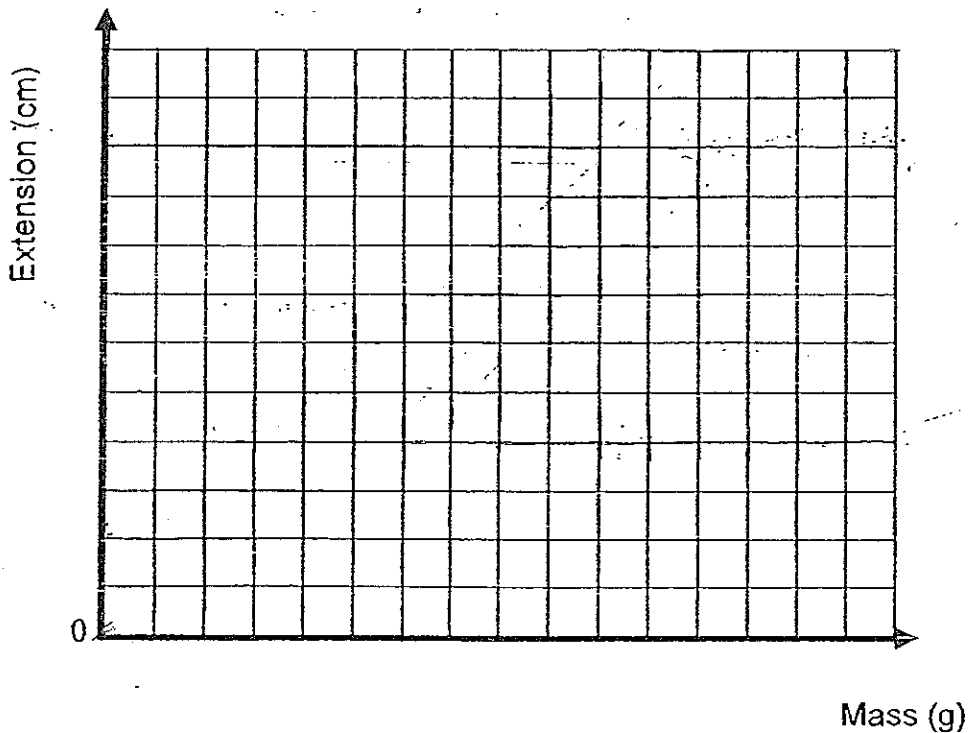

39. A group of students wanted to find out the effect of a stretched elastic band on the distance travelled by a tennis ball up a ramp. The set-up (not drawn to scale) was prepared as shown below. They measured the distance the ball travelled up the ramp from point X.

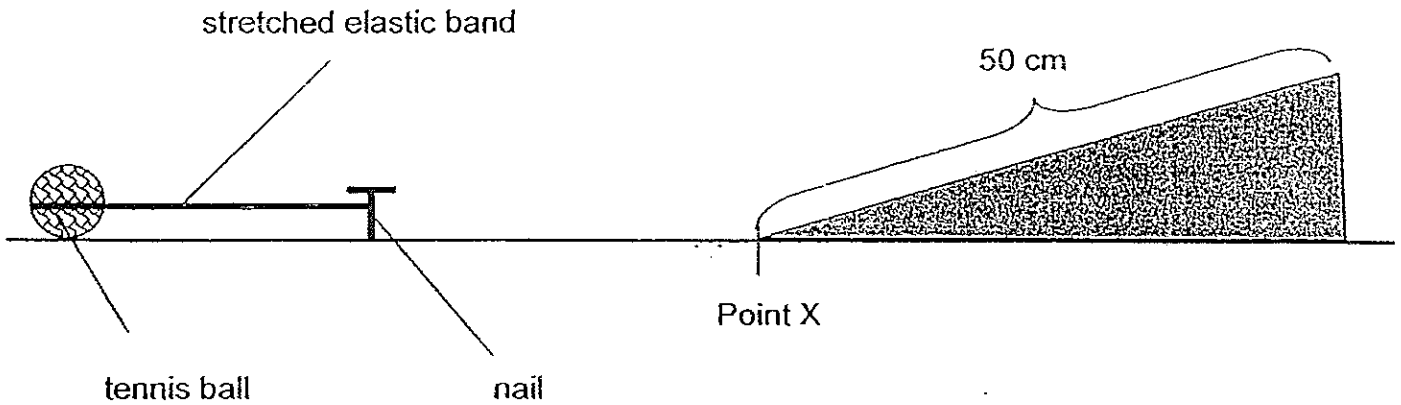

The results were recorded as shown below.

Distance between tennis ball and the nail (cm)	Distance travelled by the ball up the ramp (cm)			
	First try	Second try	Third try	Average
10	12.6	13.0	12.8	12.8
15	36.8	36.0	36.4	36.4
20	49.2	48.2	48.4	48.6

- (a) What is the reason for performing three tries before taking the average reading? [1]

- (b) They were not able to find the distance travelled by the ball up the ramp when it was placed 25 cm away from the nail. Why? [2]

40. The diagram below shows a torch. It lights up when the switch is pushed to the right.

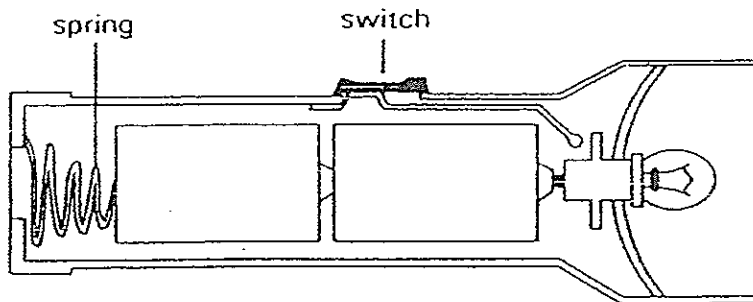

(a) Write down below the energy changes when the switch is pushed to the right. [1]

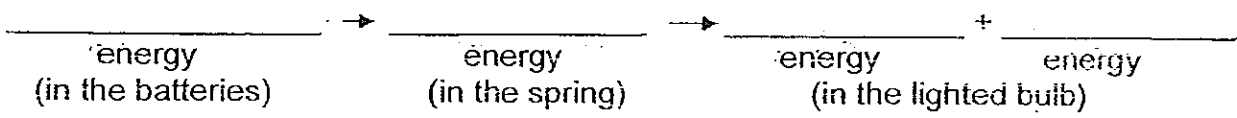

(b) Name the energy in the compressed spring that pushed the batteries against the bulb. [1]

_____ energy

41. List the similarities and differences between the Earth and the Moon in the graphic organiser below. [2]

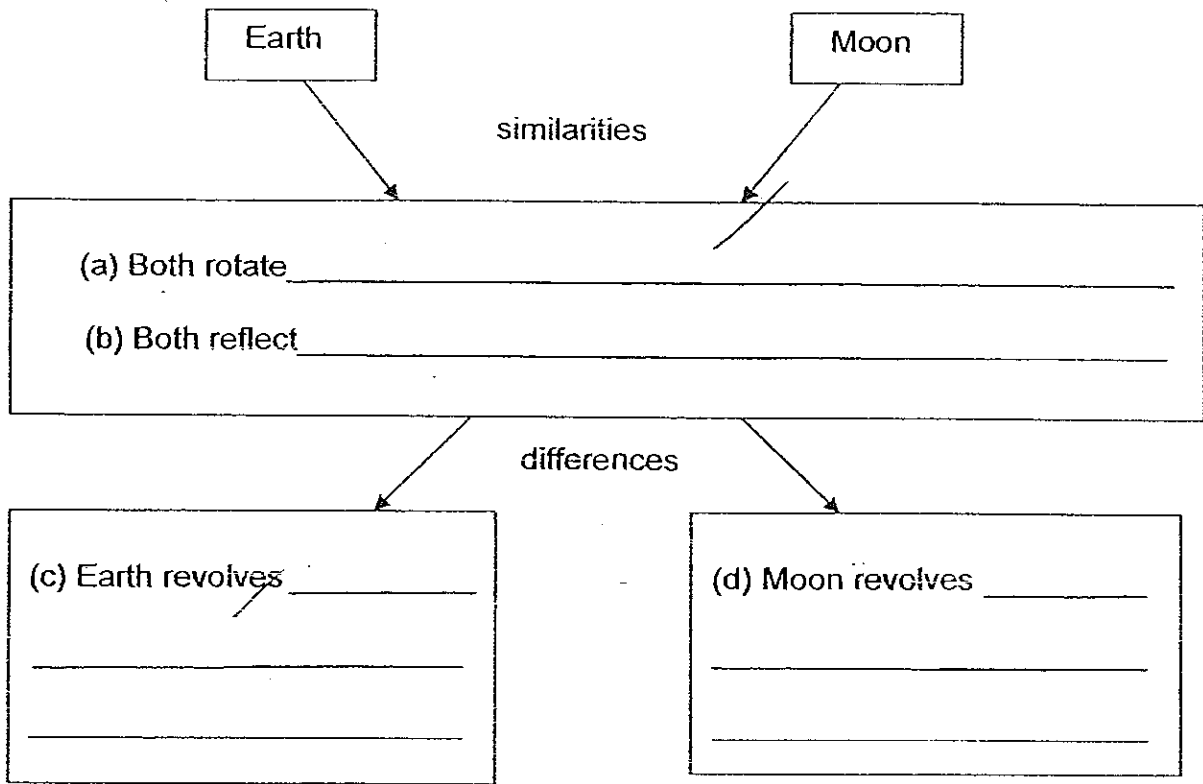

42. The diagram below shows an empty beaker being filled slowly with water. The spiral was not moving.

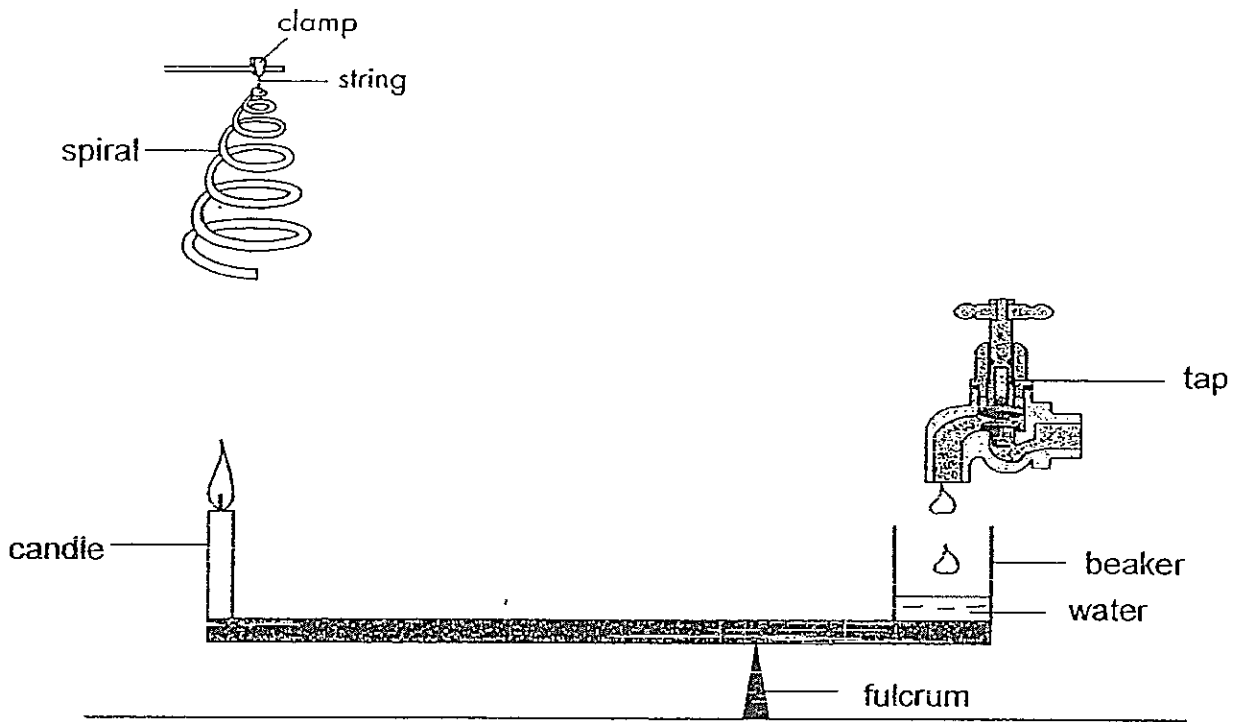

- (a) What would happen to the spiral when the beaker is filled up? [1]

- (b) Explain your answer in (a). [1]

43. Raja poured equal amounts of water into three similar measuring cylinders. He then placed three blocks, X, Y and Z in the measuring cylinders as shown below.

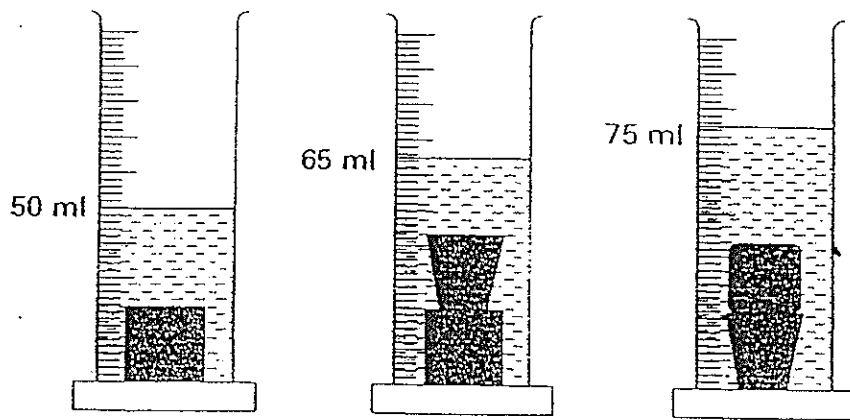

Study the statements below and put a tick (✓) in the appropriate boxes. [2]

	Statement	True	False	Not possible to tell
(a)	The volume of block Y is 15 ml.			
(b)	The temperature of the water in all the containers is 28°C.			
(c)	The volume of block Y is less than the volume of block X.			
(d)	The volume of block X is greater than the volume of block Z.			

44. K and L represent processes that cause changes in the state of water.

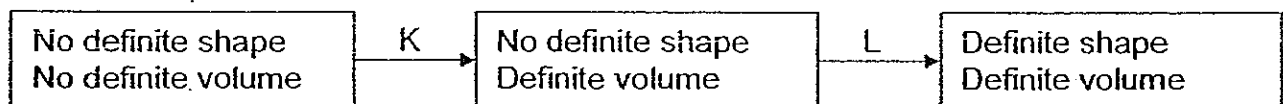

Identify the processes, K and L.

(a) Process K : _____ [1]

(b) Process L : _____ [1]

45. Joseph was given a mixture of iron filings, red beans and salt in a container.



mixture of iron filings, red beans and salt

He was provided with the following : stirrer, bar magnet, water supply, empty beaker and a fine fishing net (as shown below).



fishing net

Describe in the table below, the steps he should take to separate the red beans from the mixture, using what he was provided.

Number the steps and draw a line after each step.

[3]

Step	Description	What is separated

46. A hair dryer is used to blow a balloon which remained suspended in the air as shown below.

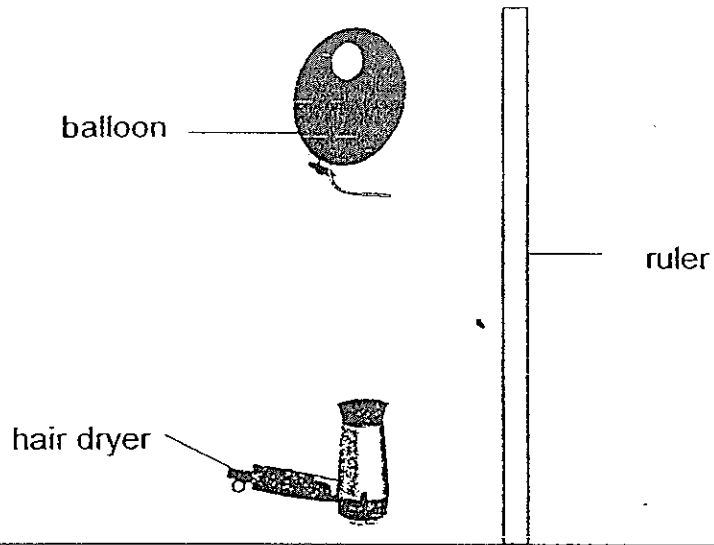

The height of the balloon from the ground is measured and the results are recorded as shown below.

Height of balloon(cm) \ Speed of hair dryer	1 st reading	2 nd reading	3 rd reading	Average reading
Low	32	34	33	33
Medium	40	42	44	42
High	52	50	54	52

- (a) What is the relationship between the speed of the hair dryer and the height of the balloon? [1]
-
- (b) When the balloon remains suspended, what can you say about the force of gravity and the upward thrust of the wind acting on the balloon? [1]
-
- (c) When the balloon is blown at Low speed for 4 minutes, it burst. Explain why. [1]
-

Tao Nan Primary School

Primary 6 Science SA1 (2008)

Answers Key

Qn no.	Ans
1	2
2	3
3	3
4	2
5	2
6	1
7	3
8	2
9	1
10	1

Qn no.	Ans
11	3
12	3
13	2
14	4
15	4
16	3
17	1
18	1
19	1
20	1

Qn no.	Ans
21	4
22	1
23	2
24	2
25	1
26	4
27	2
28	2
29	4
30	4

- 31a. Balsam plant, staghorn fern
 31b. grasshopper
 31c. dolphin, snake
 31d. duck

31b. The pattern of dispersal in X shows that the wind blew from a specific direction and scattered the seeds in that manner while the pattern in Z shows that the fruits were scattered close together.

- 32a. T (b) F
 32c. T (d) T

33a

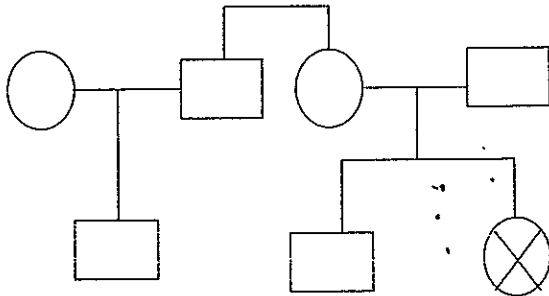

33b. She has one cousin.

- 34a. B
 34b. D

- 35a. The type of wood.
 35b(i). The height of metal stand.
 (ii). Thickness of wood.

- 36a. It will still be suspended in the air.
 36b. The paper clip will fall to the ground.
 36c. The sheet of steel is magnetic, so the magnet will attract the sheet of steel instead of the paper clip as magnetism cannot through the sheet of steel.

- 37a. X b. Y

38.

Mass (g)	Initial length (cm)	Final length (cm)	Extension (cm)
0	6cm	6cm	0cm
20	6cm	10cm	4cm
30	6cm	12cm	6cm
60	6cm	18cm	12cm

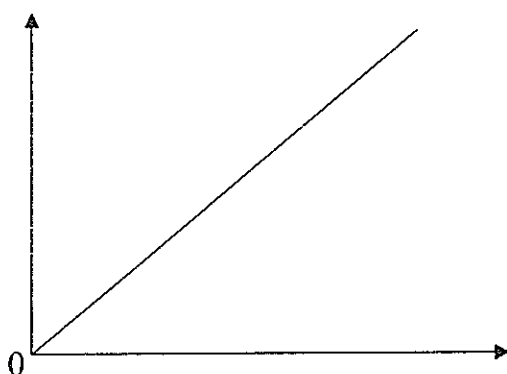

- 39a. He wanted to have an accurate average reading.
 39b. The ball travelled up the ramp and dropped down.
- 40a. Chemical potential energy → electrical energy → heat energy → light energy
 40b. Potential
- 41a. On their own axis.
 41b. Light from the sun.
 41c. Around the sun.
 41d. Around the earth.
- 42a. The spiral will start to turn.
 42b. When the beaker is filled up, it tilts the lever thus pushing the candle up, and the hot air that rises from the candle flame turns the spiral.
- 43a. T (b) Not (c) Not (d) F
- 44a. condensation
 44b. freezing

45. **Step 1 : Pour water and stir the mixture**
 Step 2 : Pour the mixture into the salt and water fine fishing net.
 Step 3 : Use the bar magnet to Iron filings out of the fishing net.
- 46a. **The greater the speed of the hair dryer, the greater the height of the balloon.**
46b. **They are the same.**
46c. **The intense heat caused the air in the balloon to expand, causing the balloon to burst.**