

Index No:

--	--	--	--	--	--



**NAN HUA PRIMARY SCHOOL
PRELIMINARY EXAMINATION – 2010
PRIMARY 6**

SCIENCE

BOOKLET A

30 Multiple Choice Questions (60 marks)

Total Time for Booklets A and B : 1 hour 45 minutes

INSTRUCTIONS TO CANDIDATES

1. Write your name and index number in the space provided.
2. Do not turn over the page until you are told to do so.
3. Follow all instructions carefully.
4. Answer all questions.
5. Shade your answers in the Optical Answer Sheet (OAS) provided.

Booklet A		/ 60
Booklet B		/ 40
Total		/ 100

Name: _____ () Class: P 6 _____

Date: 26 August 2010

Parent's Signature: _____

Section A: (20 x 2marks = 40marks)

For each question from 1 to 30, four options are given. One of them is the correct answer. Make your choice (1, 2, 3 or 4). Shade the correct oval (1, 2, 3 or 4) on the Optical Answer Sheet.

1. Aiko set up the apparatus as shown in the diagram below. She left both set-ups in a warm dark place for 24 hours. The limewater in Set-up A turned chalky but the limewater in Set-up B remained unchanged.

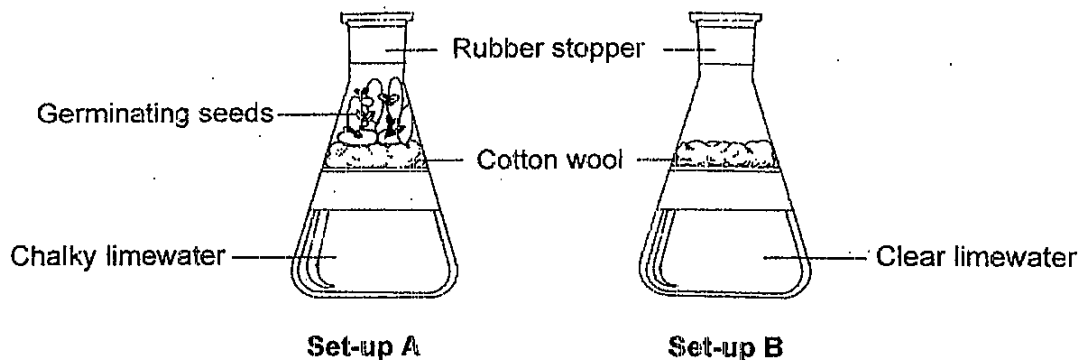

She was trying to find out if _____.

- (1) oxygen will turn limewater chalky
- (2) carbon dioxide will turn limewater chalky
- (3) oxygen was given out during germination
- (4) carbon dioxide was given out during germination

2. Study the food web below. P, Q, R, S and T are animals.

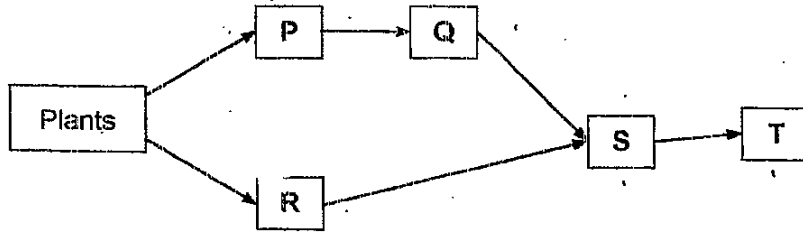

Which one of the following graphs shows how the populations of P, Q, R and T are likely to be affected if there is a mass migration of S out of this habitat?

(1)

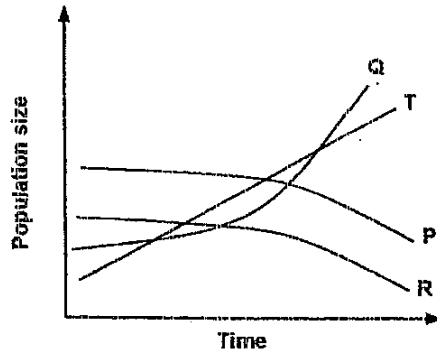

(2)

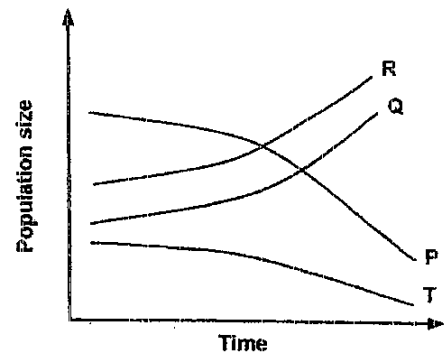

(3)

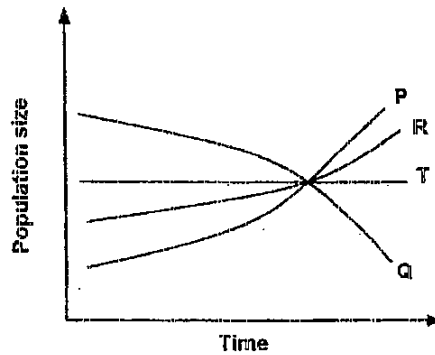

(4)

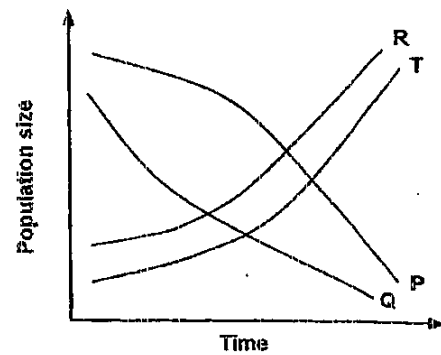

3. Study the web below.

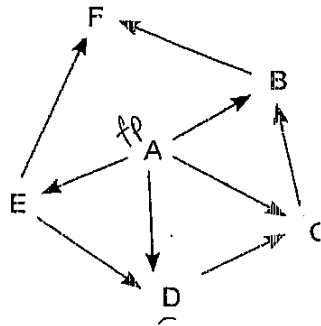

Which of the following statements are definitely true?

- W Organism F is a carnivore.
- X There are 5 food consumers in the food web.
- Y Organism C is an omnivore.
- Z When A is wiped out, populations of B, D and E will also be wiped out.

- (1) W and Z only
- (2) X and Y only
- (3) W, Y and Z only
- (4) W, X, Y and Z

4. Plants A, B, C and D have different structural adaptations which enable them to survive well in their respective habitats.

Plant A

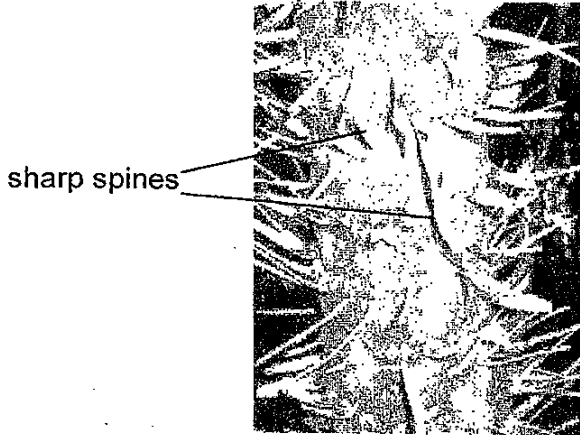

Plant B

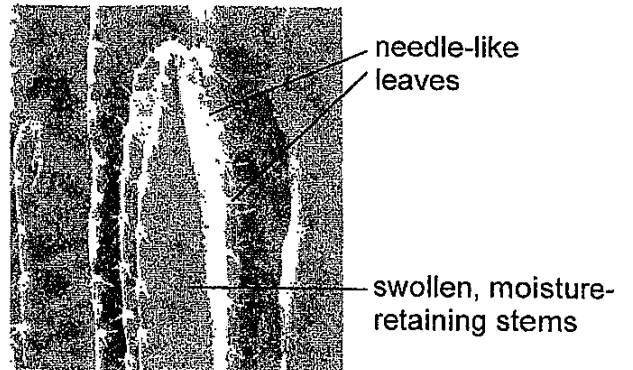

Plant C

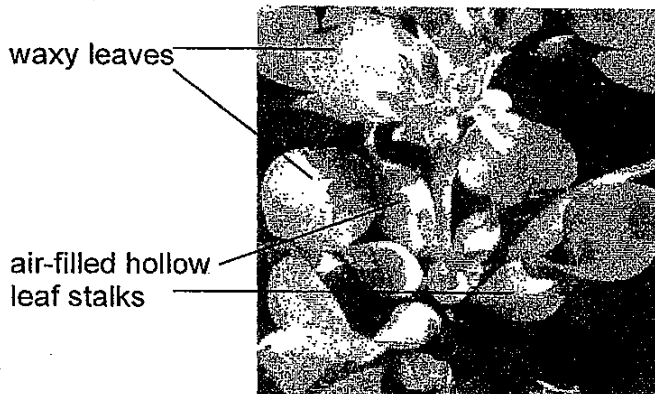

Plant D

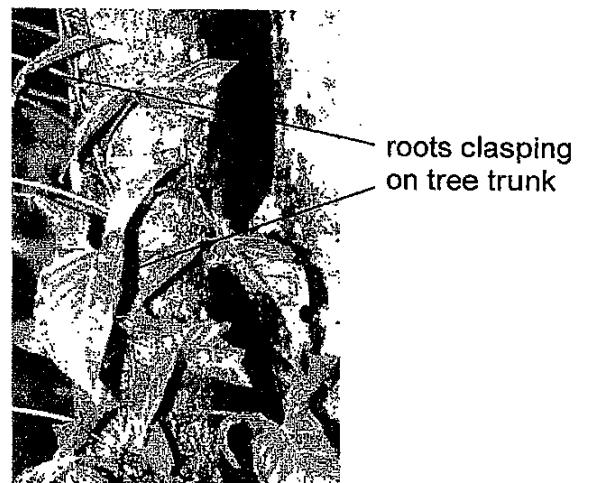

Which of the following best describes the function of the structural adaptations listed for plants A, B, C and D?

	Plant A	Plant B	Plant C	Plant D
(1)	self-defence	water storage	to stay upright	absorb nutrients
(2)	self-defence	reduce water loss	keep the plant afloat on water	climb up support
(3)	reduce water loss	self-defense	keep the plant afloat on water	absorb nutrients
(4)	hook on to support	reduce water loss	to stay upright	anchor the plant

5. The flow chart below shows the process of incinerating refuse in an incinerator plant.

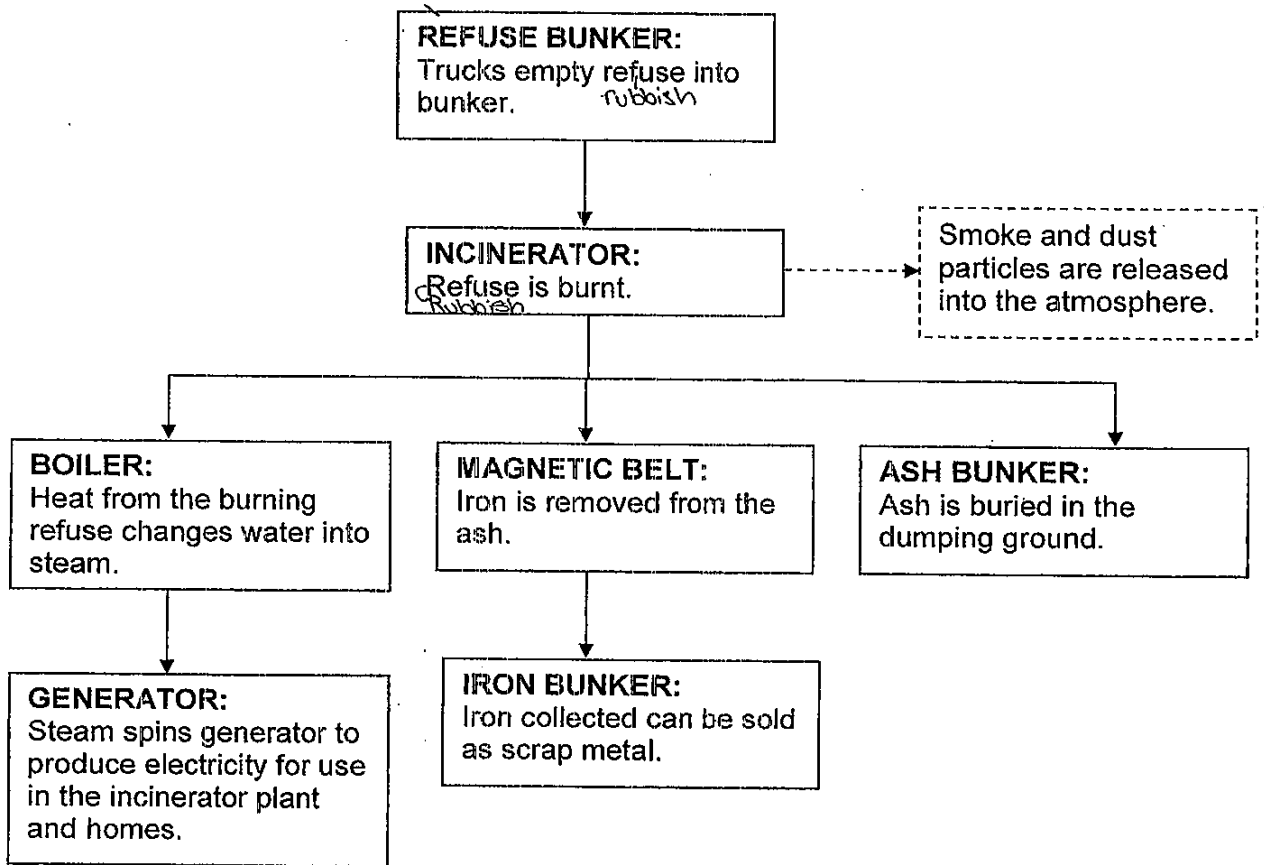

Which of the following statements are true about the process of incinerating refuse?

- A The iron removed from the ash cannot be recycled.
 - B The smoke and dust particles emitted during incineration can cause air pollution.
 - C The heat generated from the burning refuse can be used to produce electricity.
- (1) A only
(2) A and B only
(3) B and C only
(4) A, B and C

6. Donny used a piece of metal gauze to trap an ice cube at the bottom of a test tube as shown in the diagram below. Then he filled the test tube with some tap water and started heating the test tube at the point marked X.

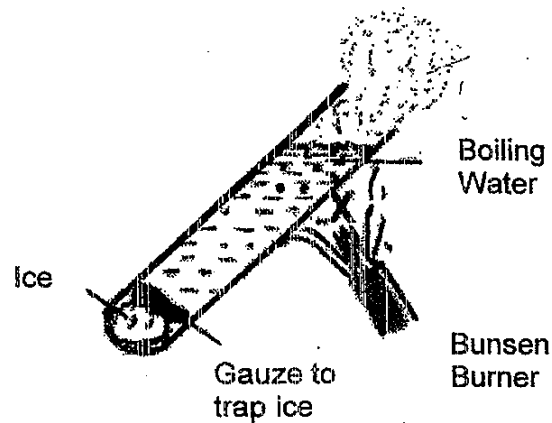

He noticed that the piece of ice did not melt when the water near the top of the test tube first started boiling. What can you conclude from his experiment?

- A Metal gauze is a good conductor of heat.
- B Water is a poor conductor of heat.
- C Ice is a poor conductor of heat.

- (1) A only
- (2) B only
- (3) A and B only
- (4) A, B and C

7. The diagram below represents the human male reproductive system.

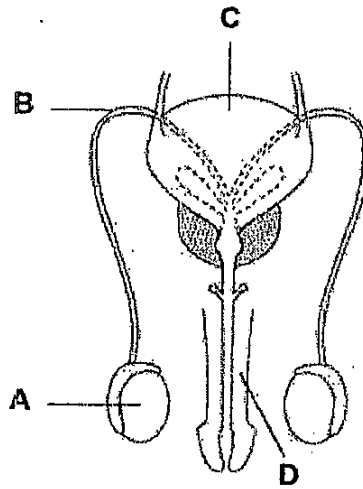

Which of the letters A, B, C or D indicates a structure that produces the reproductive cells for internal fertilization?

- (1) A
- (2) B
- (3) C
- (4) D

8. Andy labelled two identical bottles X and Y. He poured 400 ml of water into each bottle. A young plant with roots was placed in bottle X while bottle Y was the control. Both bottles were placed near the window. Andy recorded the amount of water left in the bottles X and Y over a period of 5 days. He then plotted the results in a graph.

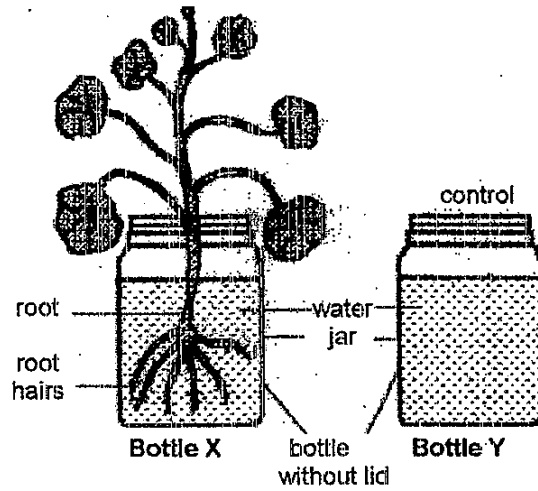

Which one of the following graphs correctly shows the changes in the amount of water in both bottles over the period of 5 days?

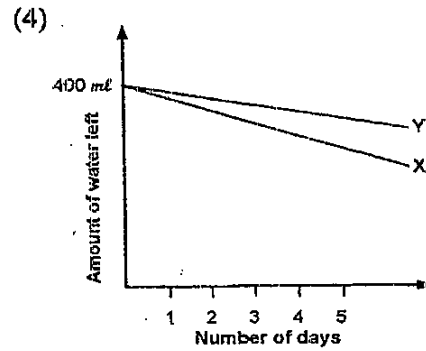
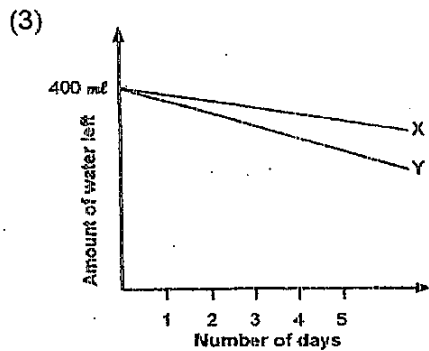
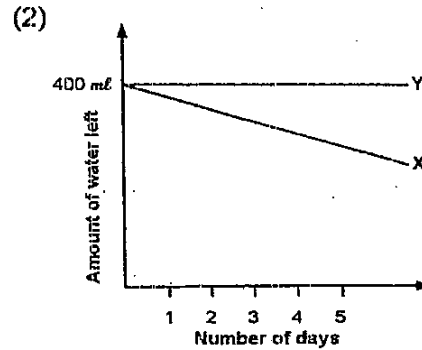
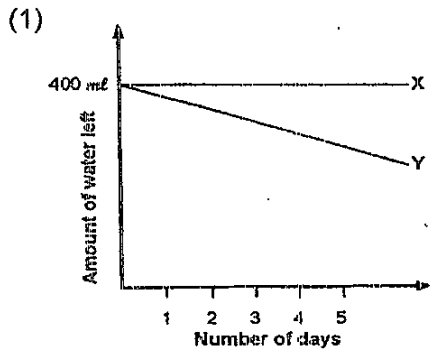

9. The following table shows the boiling and melting temperature of four different substances, S, T, U and V.

Substances	S	T	U	V
Boiling temperature ($^{\circ}\text{C}$)	110	99	95	85
Melting temperature ($^{\circ}\text{C}$)	97	68	33	25

Based on the information in the table above, which of the following statements are true of substances, S, T, U and V?

- A Substance V is in the gaseous state at 90°C .
- B Substances U and V are in the solid state at 40°C .
- C Substance T will change from liquid to solid state when cooled from 90°C to 60°C .
- D Substance S will change from the solid to liquid state when heated from 30°C to 105°C .

- (1) A and D only
- (2) B and C only
- (3) A, B and C only
- (4) A, C and D only

10. Which of the following characteristics are true for all living things?

- A They need water, food and air.
- B They move around from place to place.
- C They reproduce by giving birth to young alive.
- D They respond to changes in their environment.

- ~~(1)~~ A and D only
- ~~(2)~~ A, B and C only
- ~~(3)~~ B, C and D only
- ~~(4)~~ A, B, C and D

11. Tim took 4 magnets and dipped the shaded ends of the magnets into a pile of staples.

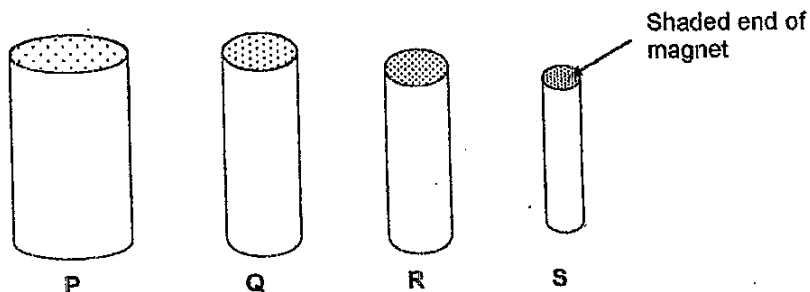

Then he counted the number of staples picked up by the shaded end of each magnet. He recorded his results in the table below.

Magnet	Number of staples picked by the magnet
P	29
Q	27
R	31
S	25

Based on the results above, which one of the following conclusions is correct?

- (1) The thicker the magnet, the stronger the magnetic force it exerts.
- (2) The thinner the magnet, the weaker the magnetic force it exerts.
- (3) The strength of the magnetic force depends on the length of the magnet.
- (4) The strength of the magnetic force does not depend on the size of the magnet.

12. Tom is free-wheeling down a slope on his bicycle. Which one of the following graphs below shows the relationship between the kinetic energy he possesses and the distance he travels down the slope?

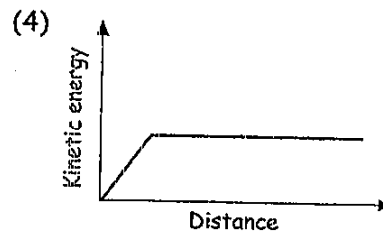
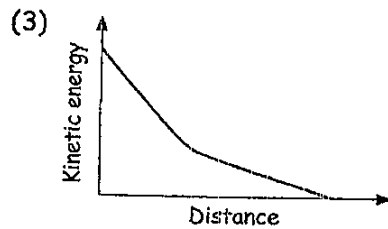
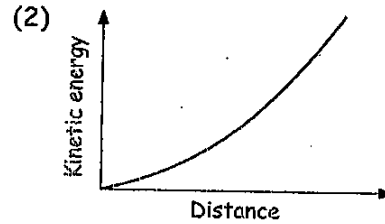
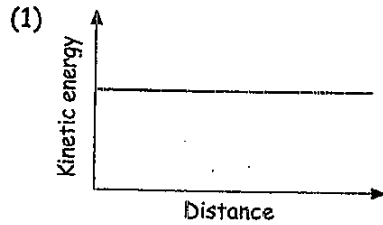

13. Four pupils came up with the following conclusions regarding decomposers.

Jason: They help make the soil fertile.
Gabriel: They help to get rid of dead organisms and wastes.
Natalie: They make their own food and purify the air.
Grace: They speed up the process of decay by breaking down plant and animal wastes into smaller pieces.

Who have made the correct conclusions?

- ~~(1)~~ Natalie and Grace
~~(2)~~ Jason and Gabriel
~~(3)~~ Jason, Gabriel and Grace
~~(4)~~ Gabriel, Natalie and Grace

14. The changes in the intensity of light and temperature of a particular habitat were recorded throughout the day. The graph and table below show the intensity of light and temperature of the habitat respectively.

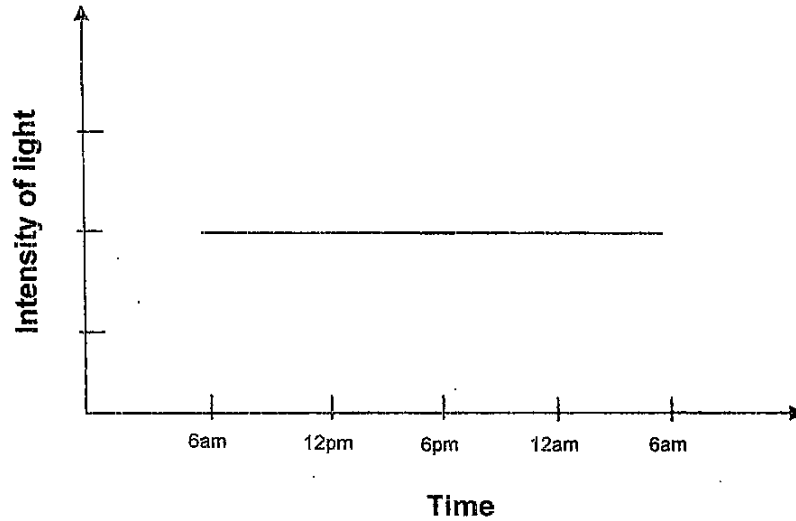

Time	6am	12pm	6pm	12am	6am
Temperature (°C)	27.5	30.5	30.0	28.5	28.5

Which of the following habitats is most likely to have the conditions described above?

- (1) Pond
- (2) Leaf litter
- (3) Seashore
- (4) School field

15. The photographs below show the skulls of four mammals. No teeth are missing from the skulls. Based on the physical structures of the teeth, which one of the mammals has a herbivorous diet?

(1)



(2)

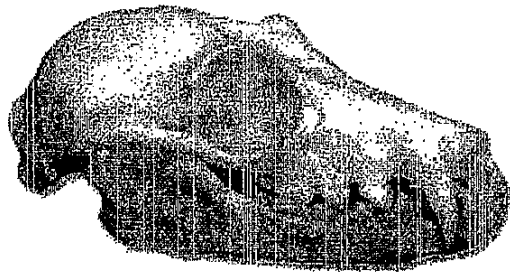

(3)

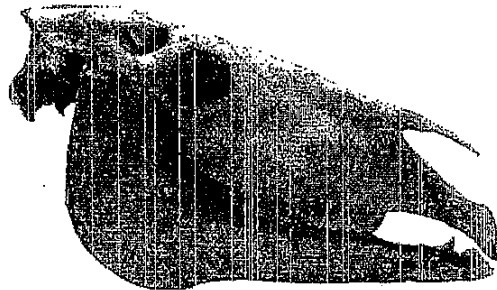







(4)

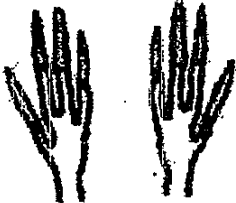

16. The Wonka is a mammal that digs and lives in burrows by the river or lake. It is able to swim and hunts for food underwater.

Which one of the following pairs of fore and hind limbs are most likely to be those of Wonka?

	Fore limbs	Hind limbs
(1)		
(2)		
(3)		
(4)		

For questions 17 and 18 use the information below.

The map below shows the location of some factories along a river.

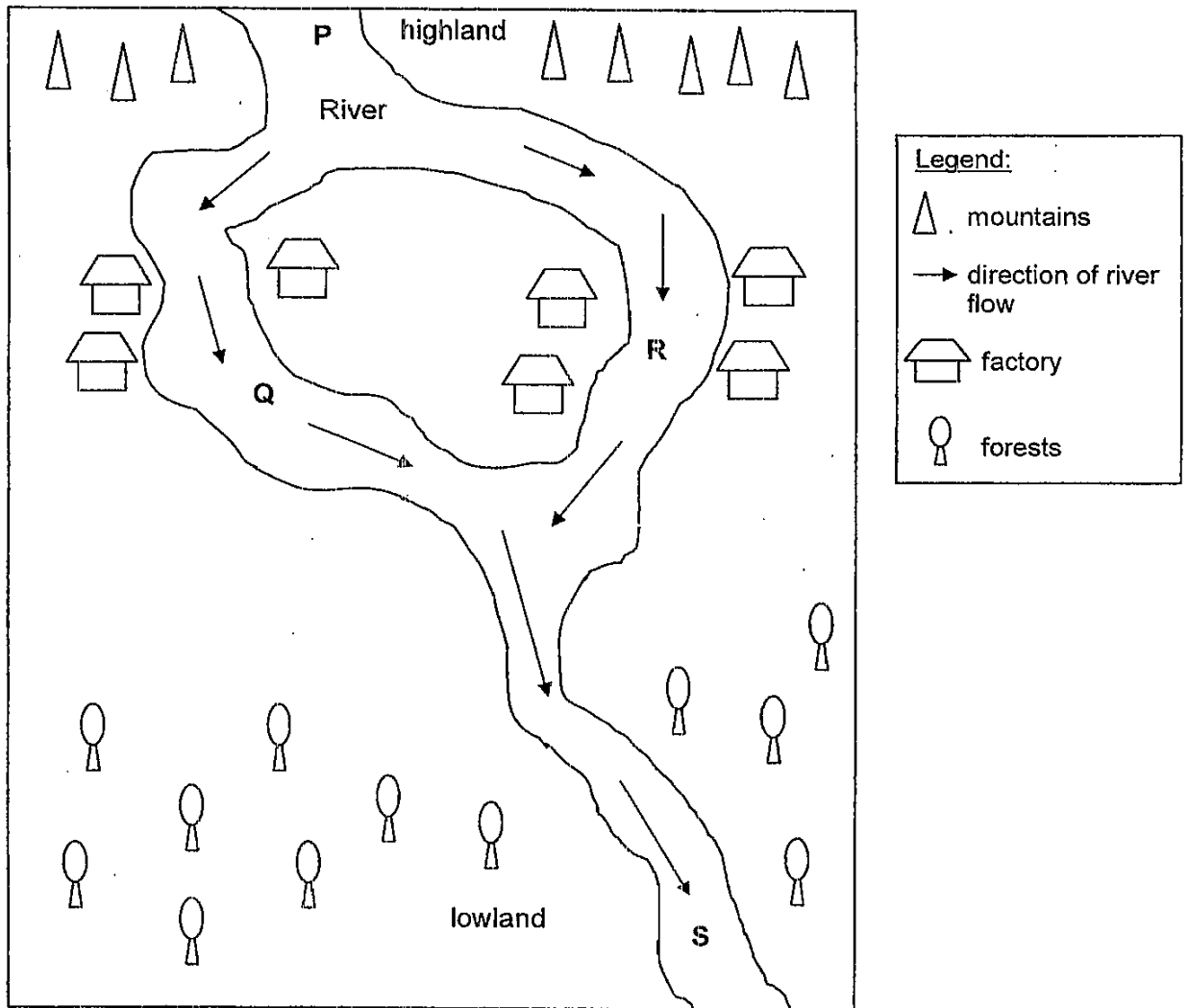

17. Each of the factories shown in the map has been illegally disposing toxic wastes that pollute the river. The toxic wastes are harmful to the organisms living in the river.

Samples of water are collected from different parts of the river, P, Q, R and S. Which one of the following graphs correctly reflects the number of organisms found in each parts of the river?

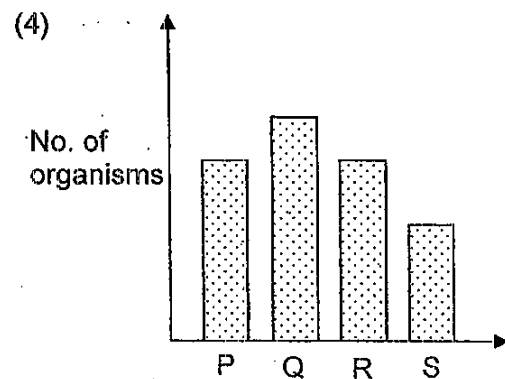
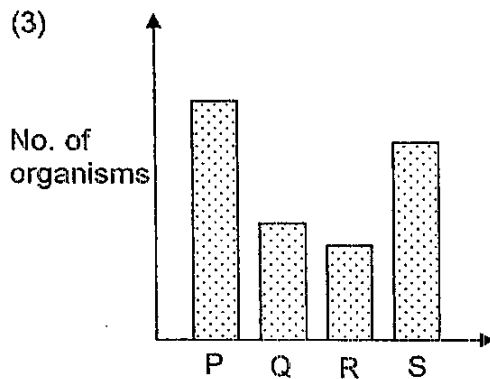
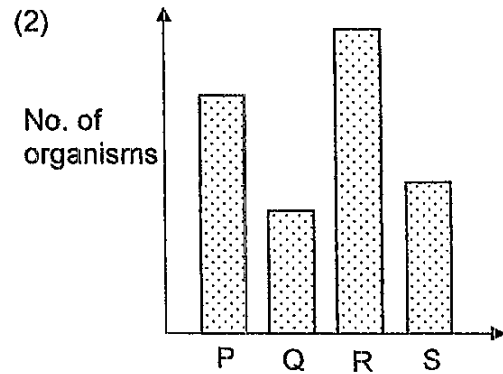
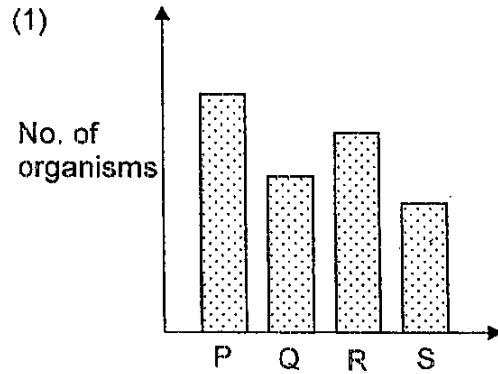

18. Some environmental inspectors want to conduct an investigation on the change in the population size of the organisms before and after pollutants were discharged into the river. At which part(s) of the river should they collect water sample(s) for the investigation?

- (1) Parts P only
- (2) Parts S only
- (3) Parts P and Q only
- (4) Parts R and S only

19. A beaker of water with ice cubes is placed in an air-tight box as shown in the diagram below.

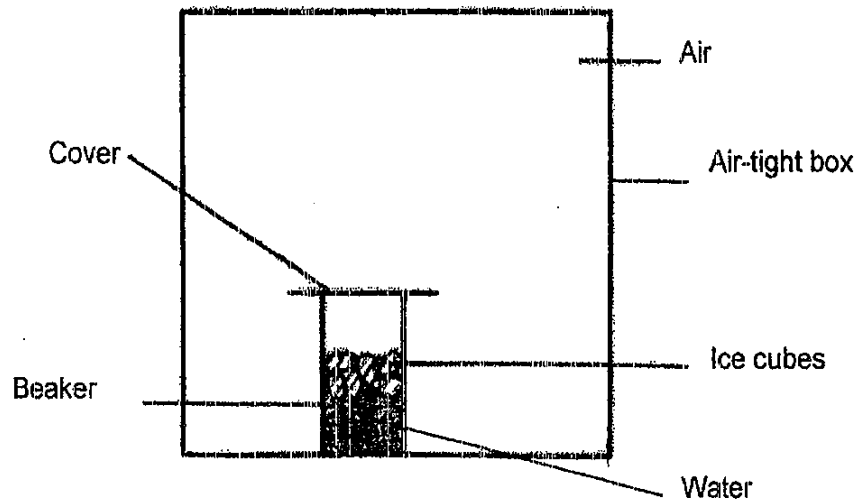

What will happen to the air in the box after 20 minutes?
The air in the box will _____.

- A become cooler
 - B become warmer
 - C become slightly less humid
 - D contain more water vapour
- (1) A and C only
(2) A and D only
(3) B and C only
(4) C and D only

20. Two test tubes, A and B, each containing the same number of seeds were set up as shown in the diagram below. The set-ups were left for days at room temperature. After 5 days, it was observed that the seeds in test tube B had germinated but not those in test tube A.

In the experiment, Solution A absorbs oxygen and Solution B absorbs carbon dioxide.

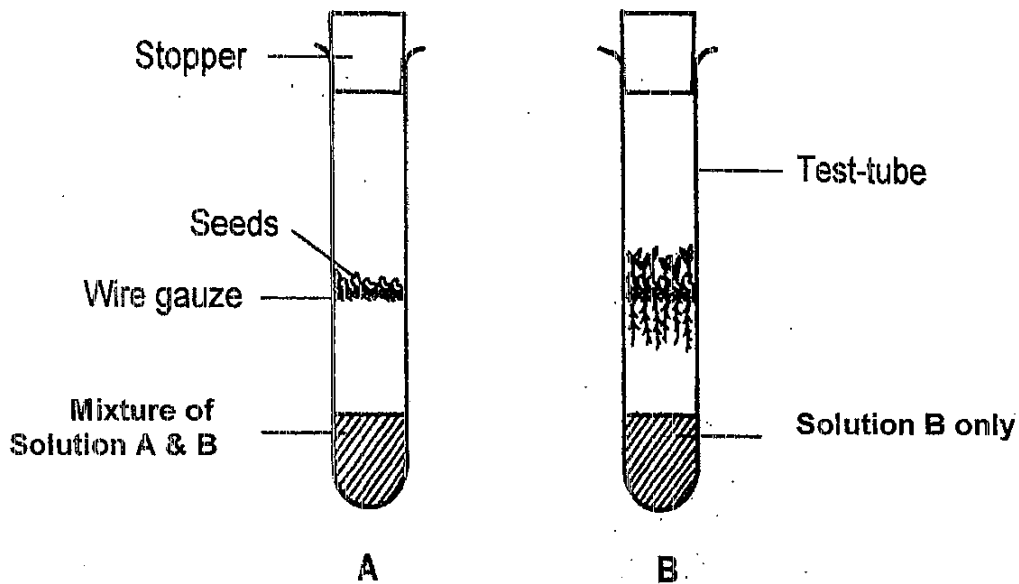

What can you conclude from the above experiment?

- (1) Both oxygen and carbon dioxide are needed for seeds to germinate.
- (2) Both oxygen and carbon dioxide are not needed for seeds to germinate.
- (3) Seeds do not need carbon dioxide to germinate.
- (4) Seeds do not need oxygen to germinate.
21. Asexual reproduction involves only one parent. Amoeba is an example of an organism that undergoes this type of reproduction.

What can you conclude about the offspring of this type of reproduction?

- (1) The offspring receives an incomplete set of traits from the parent.
- (2) The offspring receives only one-half of the traits from the parent.
- (3) The offspring receives completely different traits from the parent.
- (4) The offspring receives an identical set of traits from the parent.

22. Siew Ling has three rods, P, Q and R, made of unknown materials. She placed them in various positions, X, Y and Z, in the circuit shown below.

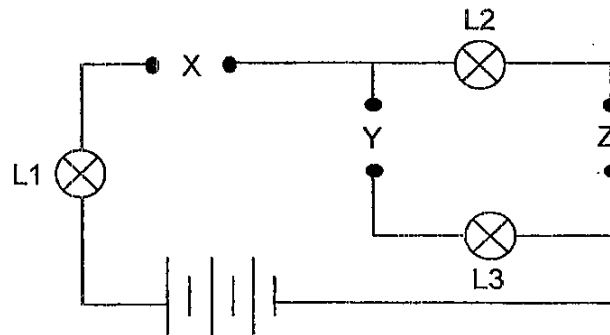

The results of the experiment were shown in the table below. When any of the lamps, L1, L2 or L3, lit up during the experiment, a tick (✓) was placed in the box.

Q - not a conductor of electricity

Positions where rods were placed			Lamp		
X	Y	Z	L1	L2	L3
P	Q	R	✓	✓	
Q	R	P			
R	P	Q	✓		✓

Which one of the inferences can she make?

- ~~(1)~~ Only rod R is not able to conduct electricity.
- ~~(2)~~ Only rods P and Q are able to conduct electricity.
- ~~(3)~~ Only rods P and R are able to conduct electricity.
- ~~(4)~~ Rods Q and R are better conductors of electricity than rod P.

23. Melissa conducted an experiment in a well-lit room to find out how the position of an object affected the image in a pinhole camera. She set up her experiment as shown in the diagram below.

When she placed the object at position Y, the image formed on the screen is as shown in the diagram below.

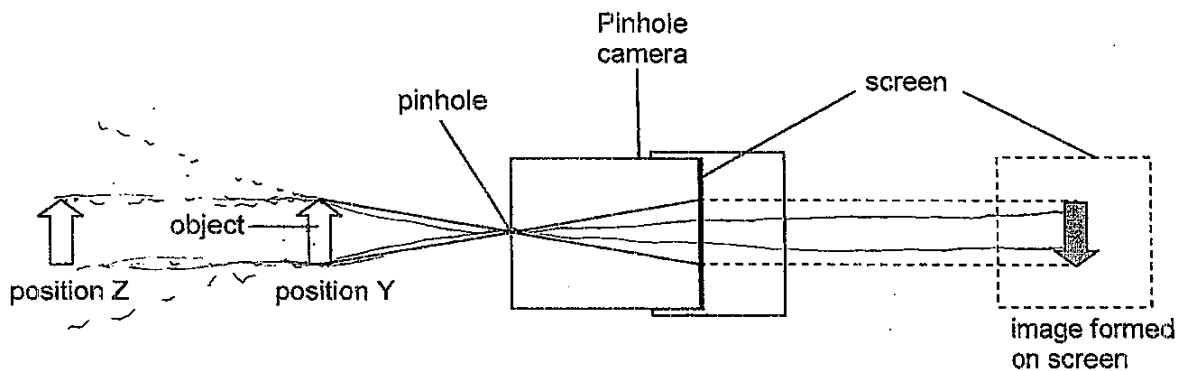

When the object was placed at position Z, which of the following would most likely be observed about the image formed on the screen?

- A The image would be upright.
 - B The image would be inverted.
 - C The image would be bigger than the object.
 - D The image would be smaller than the object.
-
- (1) A and C only
 - (2) A and D only
 - (3) B and C only
 - (4) B and D only

24. Charlotte conducted an experiment to find out the conditions needed for green beans to germinate. She set up the experiment with four containers, K, L, M and N. She placed four green beans in each of the container.

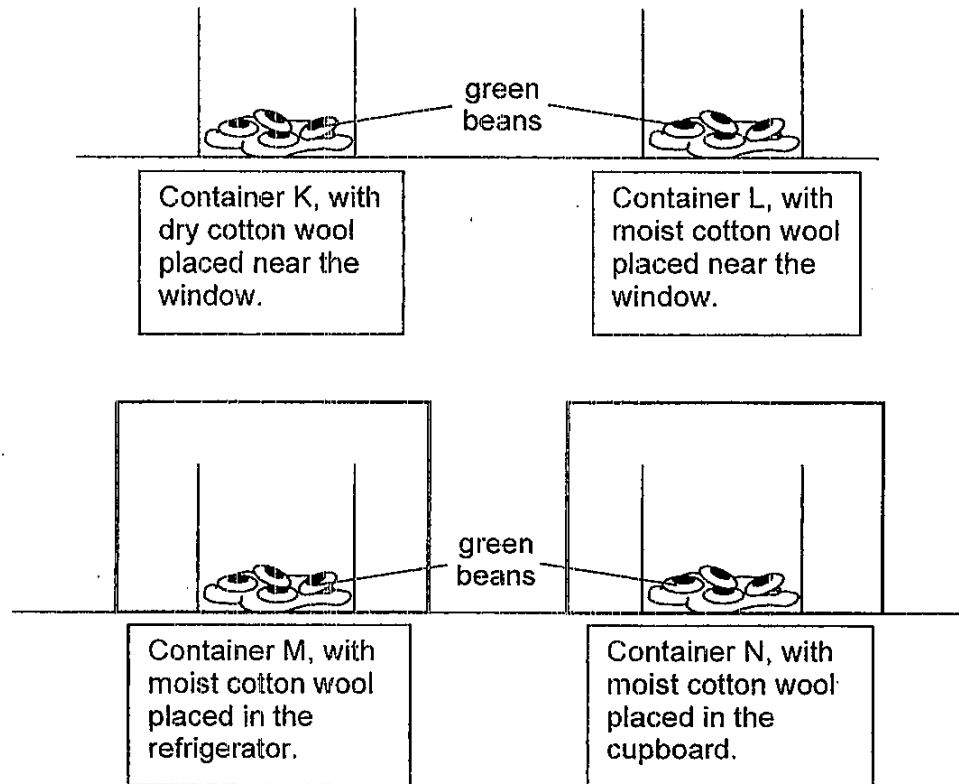

After 4 days, she observed that the green beans in containers L and N grew into young seedlings, while those in containers K and M did not.

Which of the following conclusions can be made from Charlotte's experiment?

- A Light is necessary for the seedlings to develop.
- B Water is needed for the green beans to germinate.
- C Warmth is needed for the green beans to germinate.
- D Oxygen is needed for the green beans to grow into seedlings.

- (1) A and B only
- (2) B and C only
- (3) A, C and D only
- (4) B, C and D only

25. Gases, liquids and solids are all made up of microscopic particles, but the behaviors of these particles differ in the three phases. The following diagrams represent the arrangement of these particles in its different states, A, B and C at room temperature.

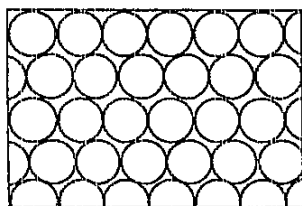

State A

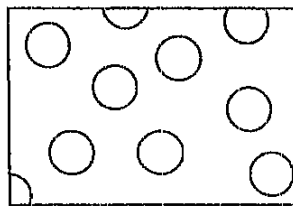

State B

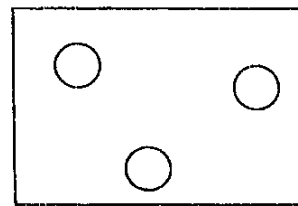

State C

Particles in the gaseous state are well separated with no regular arrangement, while particles in the liquid state are close together with no regular arrangement. Particles in the solid state are tightly packed, usually in a regular pattern.

Based on the information above, what is the most likely arrangement of particles in the respective regions D and E of an ice-cube in the process of melting?

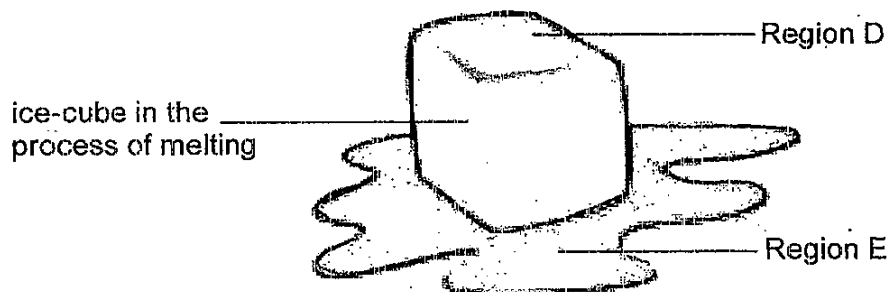

	Region D	Region E
(1)	State A	State A
(2)	State A	State B
(3)	State B	State C
(4)	State C	State B

26. Which part of a fish helps it to swim?

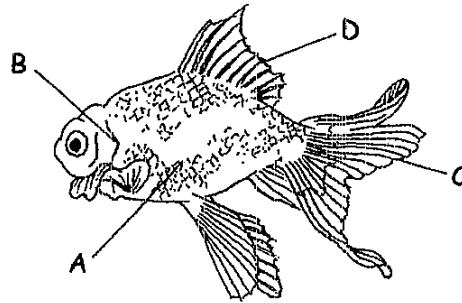

- A Scales
- B Gills
- C Tail
- D Fins

- (1) D only
- (2) C and D only
- (3) A, C and D only
- (4) A, B, C and D

27. The diagrams below show the mass of objects of different materials A, B, C and D. The objects are of identical volumes.

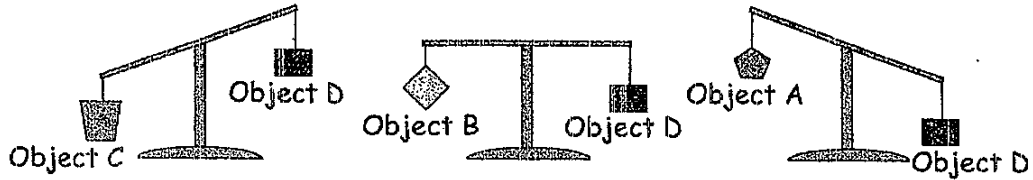

The diagram below shows the positions of Objects A and D when they are placed in water.

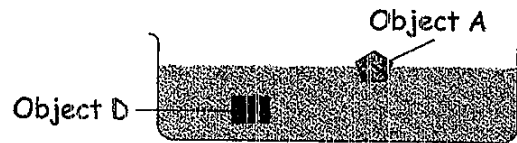

In the diagram below, P1, P2, P3 and P4 represent the positions of the objects when placed in water.

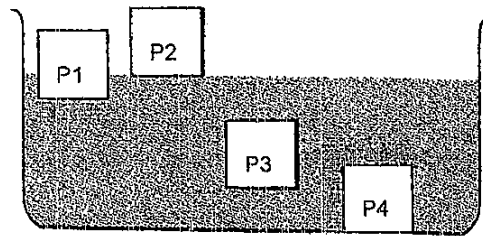

Which one of the following shows the correct positions of Objects B and C when placed in water?

	Object B	Object C
(1)	P1	P2
(2)	P1	P3
(3)	P3	P4
(4)	P2	P4

28. Bryan conducted an experiment to find out if the absence of roots affects the transport of water in plants.

He took three containers A, B and C, and filled each with the same amount of water. He put two identical plants, one plant in B and another plant with its roots cut off in C. A cover was used in each of the set-up A, B and C to hold the plant in place.

All the three containers were covered and left near a window for 3 days.

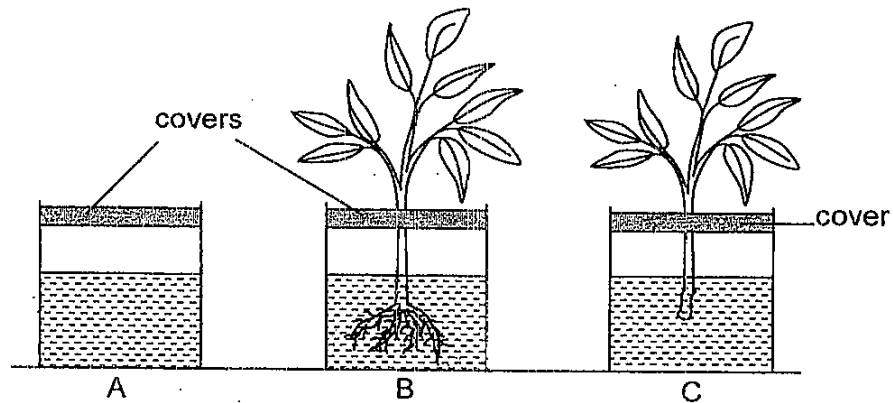

Which one of the following sets of results would he expect to observe after 3 days?

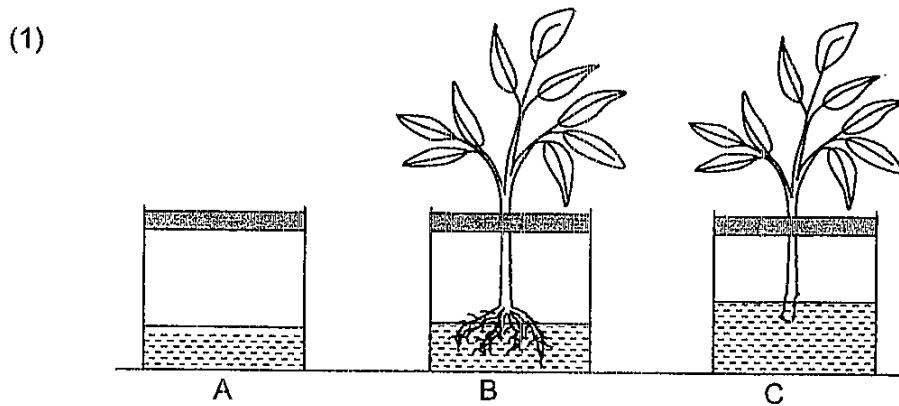

(2)

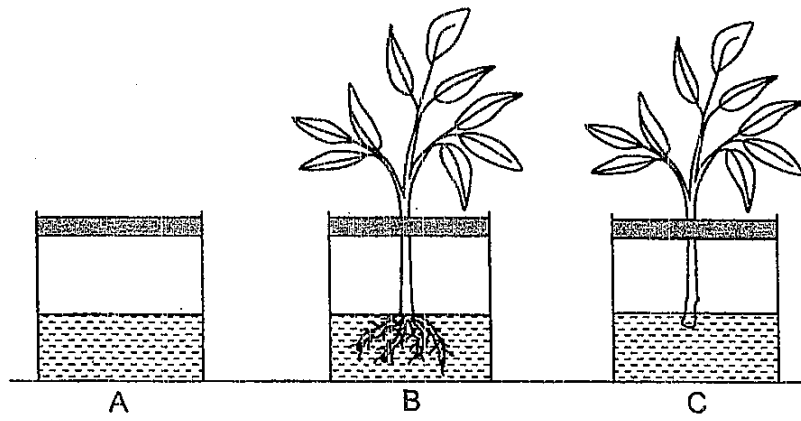

(3)

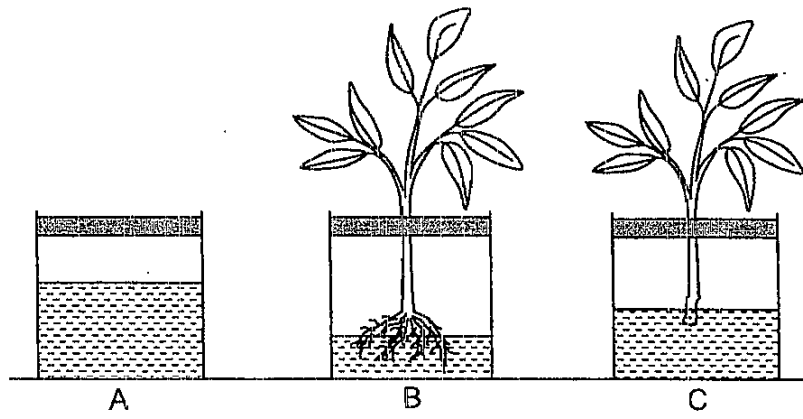

(4)

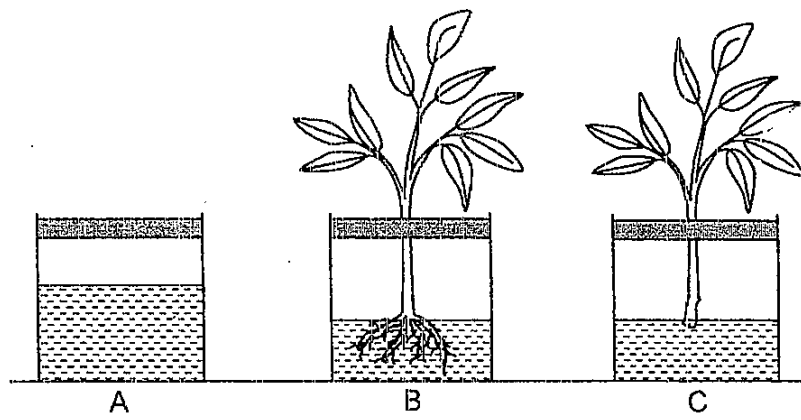

29. The diagram below shows how the circulatory, digestive and respiratory systems in our body work together.

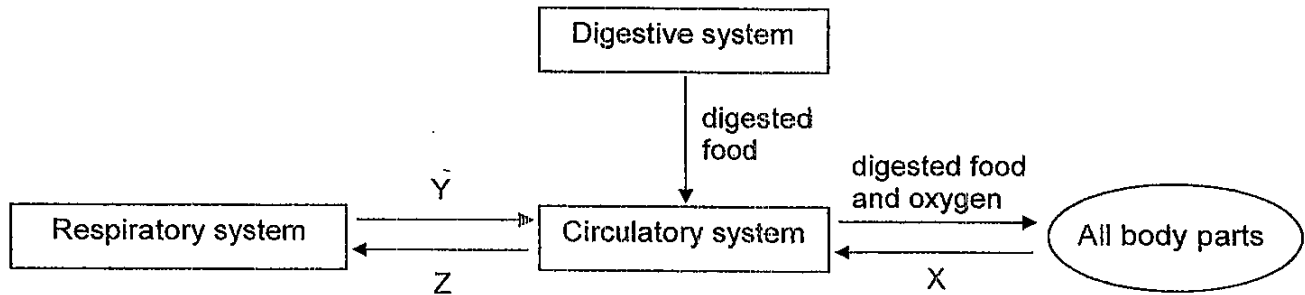

Which one of the following correctly shows the gases represented by X, Y and Z?

	X	Y	Z
(1)	oxygen	carbon dioxide	oxygen
(2)	carbon dioxide	oxygen	oxygen
(3)	carbon dioxide	oxygen	carbon dioxide
(4)	oxygen	carbon dioxide	carbon dioxide

30. Each magnet has a south pole and a north pole and it is the strongest at its poles.

The magnetic field lines between the poles of magnets can be shown with the use of iron filings.

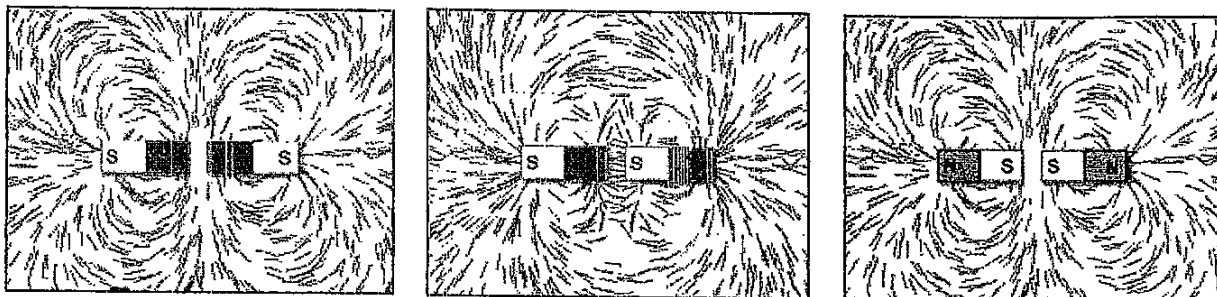

A series of magnets showing the magnetic field lines between the magnets is shown below. The poles of one magnet are labelled.

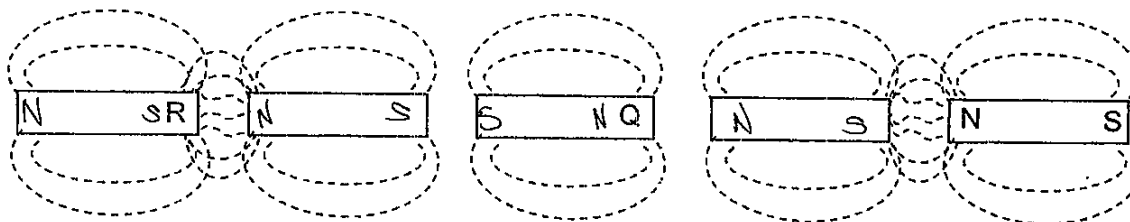

What are the poles of magnets at Q and R?

	Q	R
(1)	South	North
(2)	South	South
(3)	North	South
(4)	North	North

Index No:

--	--	--	--	--	--



**NAN HUA PRIMARY SCHOOL
PRELIMINARY EXAMINATION – 2010
PRIMARY 6**

SCIENCE

BOOKLET B

14 Open-ended questions (40 marks)

Total Time for Booklets A and B : 1 hour 45 minutes

INSTRUCTIONS TO CANDIDATES

1. Write your name and index number in the space provided.
2. Do not turn over the page until you are told to do so.
3. Follow all instructions carefully.
4. Answer all questions.
5. Write your answers in this booklet.

Section B

	/40
--	-----

Name: _____ ()

Class: P 6 _____

Date: 26 August 2010

Parent's Signature: _____

Section B: (40marks)

Write your answers to question 31 to 44.

The number of marks available is shown in brackets [] at the end of each question or part question.

31. The diagram below shows two processes.

Process A is indicated by the solid arrow lines (→).

Process B is indicated by the dotted arrow lines (···→)

(a) Fill in the boxes correctly using the following words. [1]

animals	oxygen	carbon dioxide
--------------------	-------------------	---------------------------

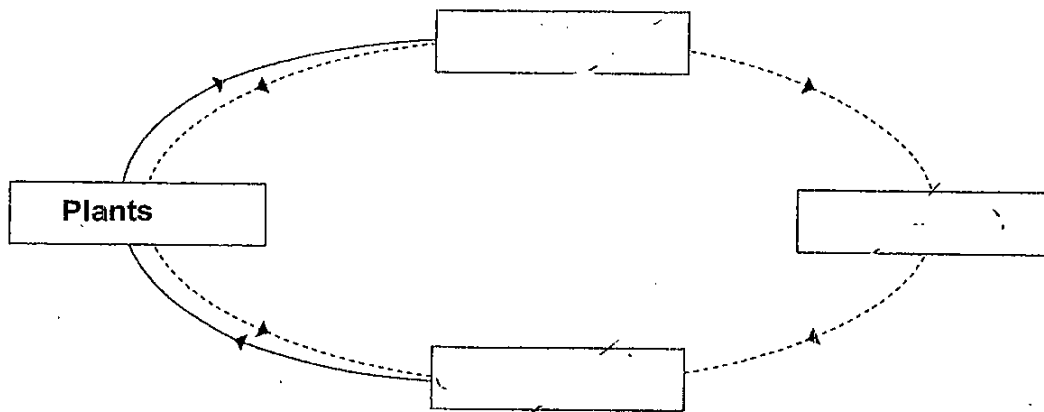

(b) Identify Processes A and B. [1]

Process A: _____

Process B: _____

Score	2
-------	---

32. A farmer spotted many aphids growing in his plantation. In order to kill the aphids, he introduced Bug A. He then recorded the number of aphids after Bug A was introduced.

After Bug A was introduced						
Day	0	2	4	6	8	10
Number of aphids	50	50	50	50	50	50

- (a) Was his solution effective? Why? [1]

Ten days later, without removing Bug A, he then introduced Bug B and recorded the number of aphids after Bug B was introduced.

After Bug B was introduced						
Day	0	2	4	6	8	10
Number of aphids	50	43	35	30	27	26

- (b) Based on the previous data, which bug, A or B, should he use to get rid of the aphids? Give a reason for your answer. [1]

Another ten days later, without removing Bug A and Bug B, he then introduced Bug C and recorded the number of aphids after Bug C was introduced.

After Bug C was introduced						
Day	0	2	4	6	8	10
Number of aphids	26	30	35	42	50	57

- (c) Based on the data above, what do you think could have happened? [2]

Score	4
-------	---

33. Study the food web below.

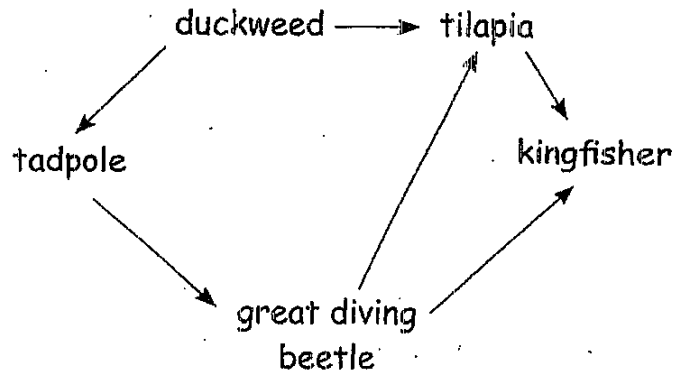

(a) How many herbivores are there in the food web? [1]

(b) What is the relationship between the kingfisher and the great diving beetle? [1]

(c) Write down one food chain that involves four organisms. [1]

Score	3
-------	---

34. The Arctic fox is well adapted to live in the cold Arctic. It has a thick coat of fur which enables it to keep warm to survive freezing cold temperatures.



The fur hairs of the Arctic fox are able to trap a layer of air between them.

- (a) Explain how would this layer of air trapped by the fur hairs help the Arctic fox to survive the freezing cold temperatures of the Arctic? [1]

Unlike the Arctic fox, humans do not have a thick coat of fur. We need to wear thick winter coats to keep us warm to endure cold temperatures.



- (b) Explain why we are able to endure cold temperatures by wearing thick winter coats. [1]

Score	/
	2

35. William conducted an investigation to find out how much a piece of styrofoam can bend before it gives way and breaks. He hung some masses on the middle of the piece of the styrofoam and measured how far it has bent.

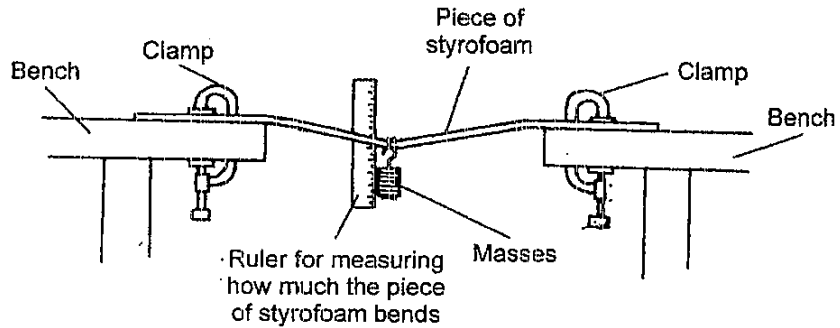

- (a) Name the force that is acting on the masses in the diagram above. [1]

The table below shows William's results.

Masses (g)	40	80	120	160
Distance bent by the piece of styrofoam (mm)	3	6	9	12

- (b) If William wanted to ensure reliability of his results, what do you think he should do? [2]

- (c) If the piece of styrofoam has bent 7.5 mm, what mass must have been hung from the styrofoam? [1]

Score	4
-------	---

36. The diagram below shows a swinging pendulum bob at 5 different positions.

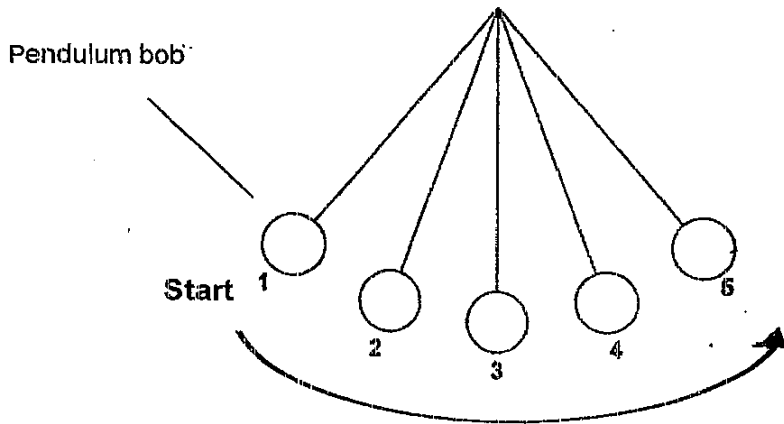

(a) At which point or points (1, 2, 3, 4 or 5) in the pendulum's swing is its kinetic energy greatest? [1]

(b) At which point or points (1, 2, 3, 4 or 5) in the pendulum's swing is its gravitational potential energy greatest? [1]

(c) The following graph shows how the amount of kinetic and gravitational potential energy changes as the pendulum moves from point 1 to point 5. Label the curves to indicate the type of energy it represents. [1]

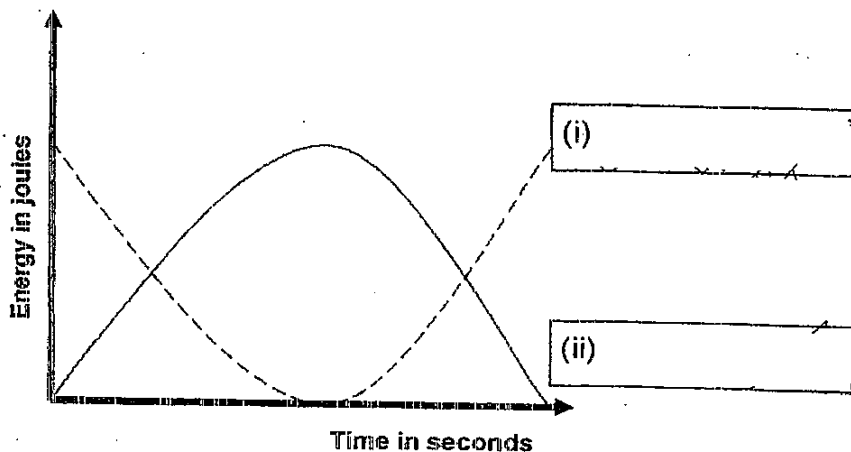

Score	3
-------	---

37. The following table shows the conditions at different depths in the ocean.

Ocean Zone	Depth (m)	Conditions
Sunlit zone	0 – 199	Warm and bright
Twilight zone	200 – 999	Cold and dim
Dark zone	1000 – 3999	Very cold and dark
Abyss	4000 – 6000	Very cold and pitch dark

The angler fish shown below has a stalk on its head that emits light. The light attracts prey for the angler fish to eat.

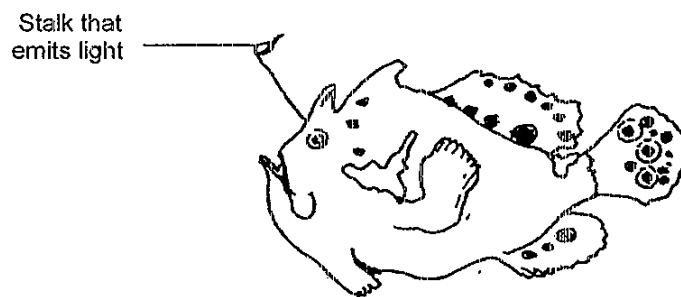

From the information given above, what is the **minimum** depth at which the angler fish would be expected to live? Provide a reason to support your answer. [2]

Score	2
-------	---

38. The diagram below shows a food web for an ecosystem.

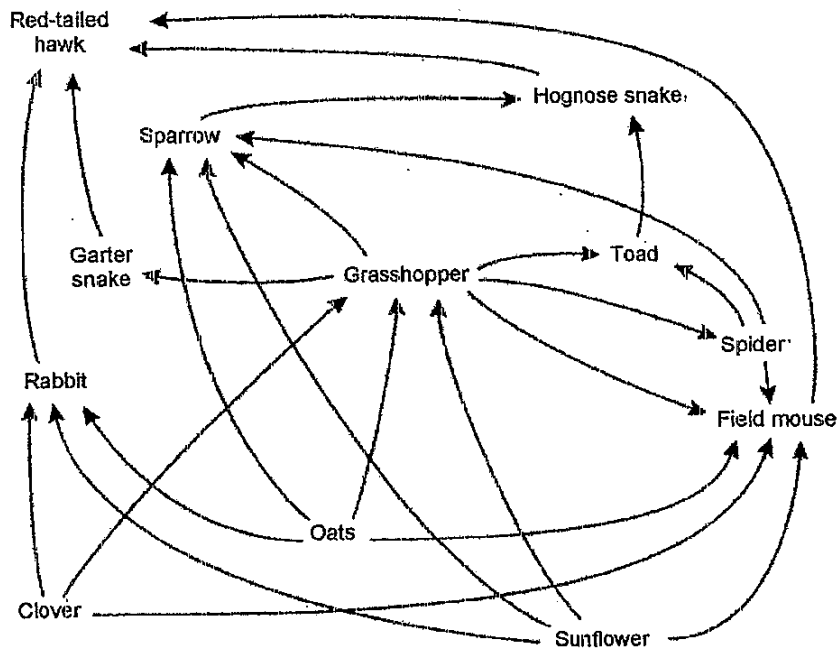

(a) Identify the food producers in this food web. [1]

(b) Study the following food chains taken from the food web above.

Sunflower → Field Mouse

Sunflower → Grasshopper → Spider → Field Mouse

It is noticed that more energy is available to the field mouse from eating sunflowers than from eating spiders. Do you agree? Explain your answer. [1]

Score	2
-------	---

39. Decorator crabs have a unique behavioural adaptation of "dressing up" themselves. These crabs dress themselves with small pieces of soft corals polyps, seaweeds, sponges, wood, or anything which they can find on the seabed. They have tiny, Velcro-like hooks on their backs to hold the objects in place.

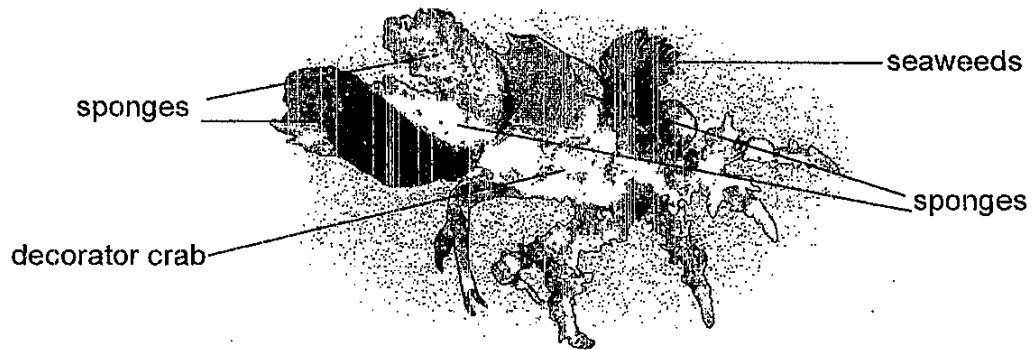

- (a) Explain how the behavioural adaptation of attaching seaweeds and sponges on its back enhances the chances of survival of the decorator crab? [2]

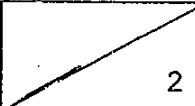
Score	
-------	---

Carrier crabs have a slightly different behavioural adaptation as compared to the decorator crabs. They carry objects on their backs using their rear legs. Sometimes, they may even carry living organisms, such as a sea urchin on their backs.

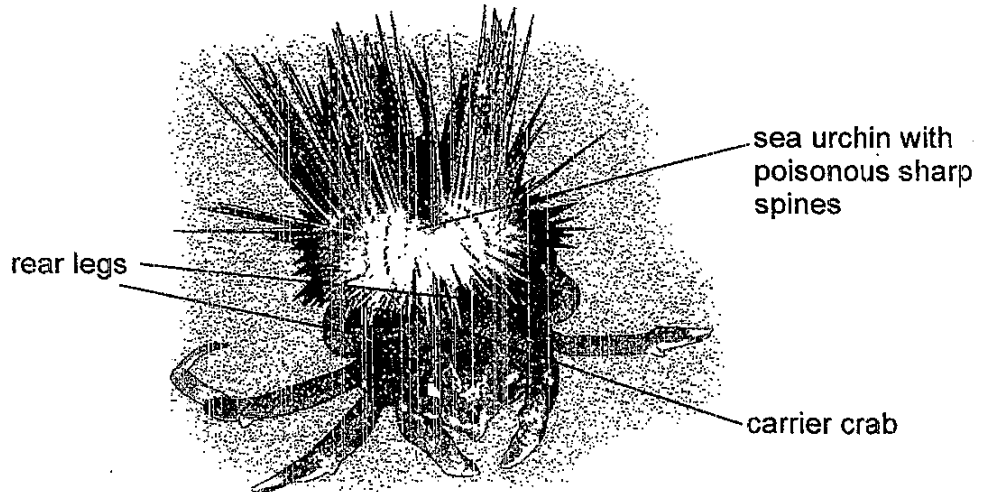

- (b) Explain how the behavioural adaptation of carrying a sea urchin on its back enhances the chances of survival of the carrier crab? [1]

Score	1
-------	---

40. The process of making Yakult, a cultured milk drink is listed below.

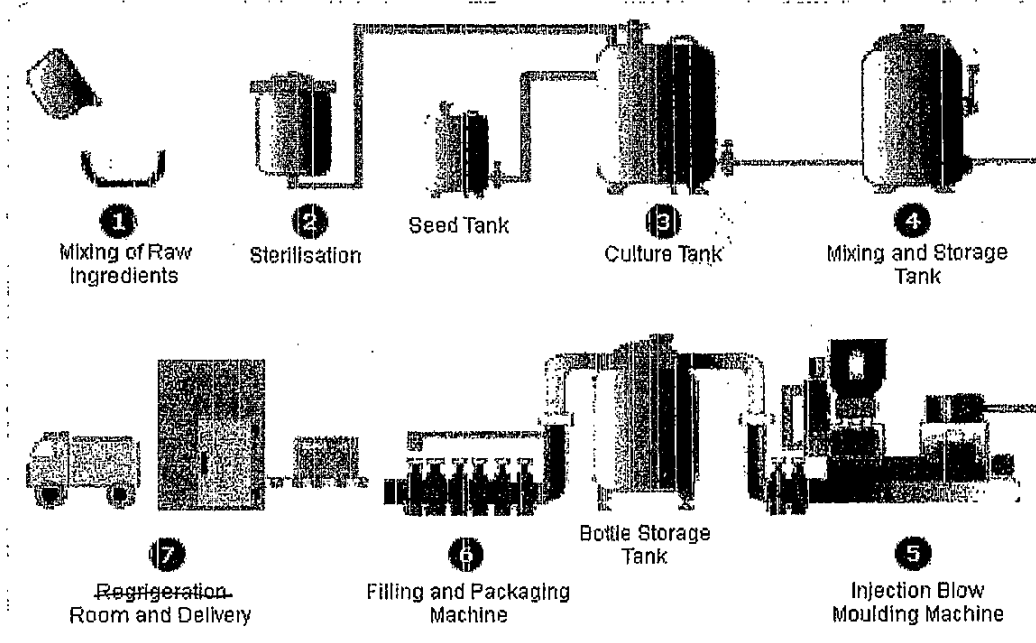

Step 1: Mixing of Raw Ingredients

Skim milk powder is mixed with sugar, glucose and filtered, sterilised water to make a sweet milky solution.

Step 2: Sterilisation

The sweet, milky solution is sterilised at a high temperature for a short time.

Step 3: Culture Tank

The temperature of the tank is reduced to 37°C and live *Lactobacillus casei* Shirota strain is added from the seed tank. The number of *Lactobacillus casei* bacteria in the solution will reach an ideal concentration in about one week.

Step 4: Mixing and Storage Tank

The concentrate is transferred to a 12,000-litre mixing and storage tank. The tank is chilled to around 2°C. Sterilised flavours, syrup solution, vitamins and calcium are added to the concentrate.

Step 5: Injection Blow Moulding Machine

The plastic bottles are produced on site. The bottles are made from polystyrene.

Step 6: Bottling and Packaging

The bottles are wrapped with individual bottle labels. Then, they are filled with Yakult, capped with a foil lid, sealed and transferred along the conveyor belt to the packaging facility.

Step 7: Refrigeration Room

Finished products are kept refrigerated before delivery to stores.

Use the above information to answer questions (a) to (c).

- (a) Explain the purpose of adding sugar to the milky solution in step 1. [1]

- (b) Explain why the milky solution must be heated to a high temperature in step 2? [1]

- (c) What is the suitable temperature for the live *Lactobacillus casei* bacteria to multiply? [1]

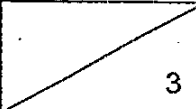
Score	
-------	---

41. The diagram below shows an electrical circuit in a home consisting of four rooms, the living room, the kitchen and two bedrooms. Five lamps, a, b, c, d and e are used to light up different rooms in the home.

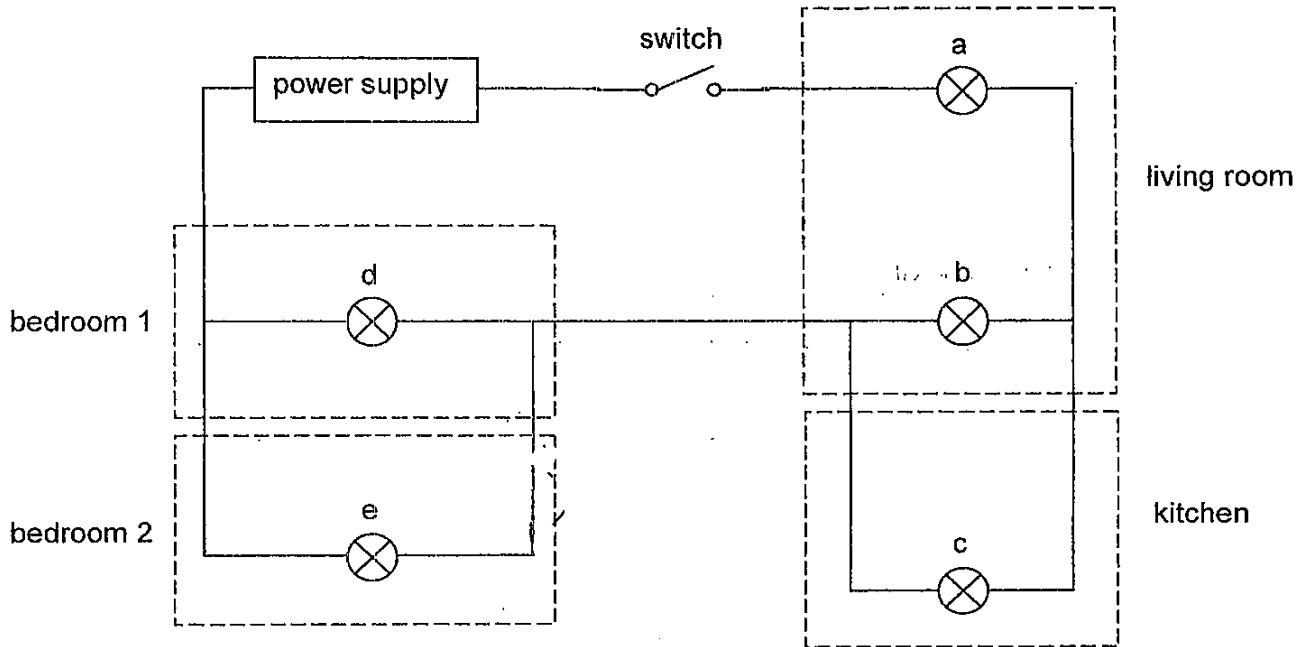

- (a) State two disadvantages in the usage of this electrical circuit in the home. [2]

Disadvantage 1:

Disadvantage 2:

- (b) Draw an "X" in the electrical circuit above to mark the position where a switch should be installed to control lamp 'e' in bedroom 2. [1]

Score	3
-------	---

42. Elton conducted an experiment to find out how the amount of light reflected by three different materials, A, B and C, is affected by the distance the material is away from the light source. He set up his experiment as shown in the diagram below.

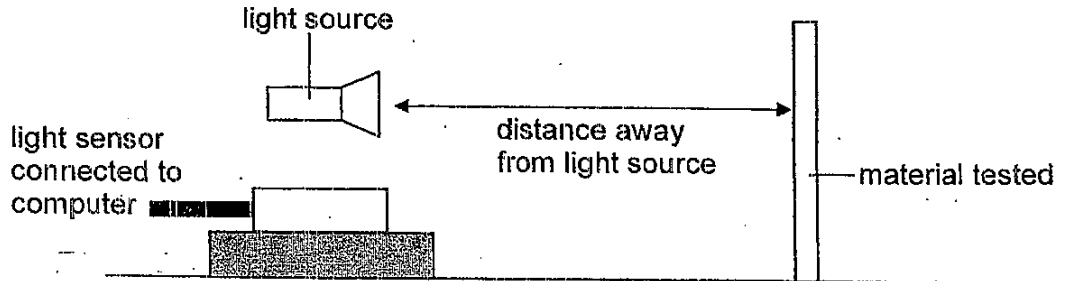

He placed the materials at different distances away from the light source and he used a light sensor to determine the amount of light that was reflected.

He recorded the results and plotted the results in the graph below.

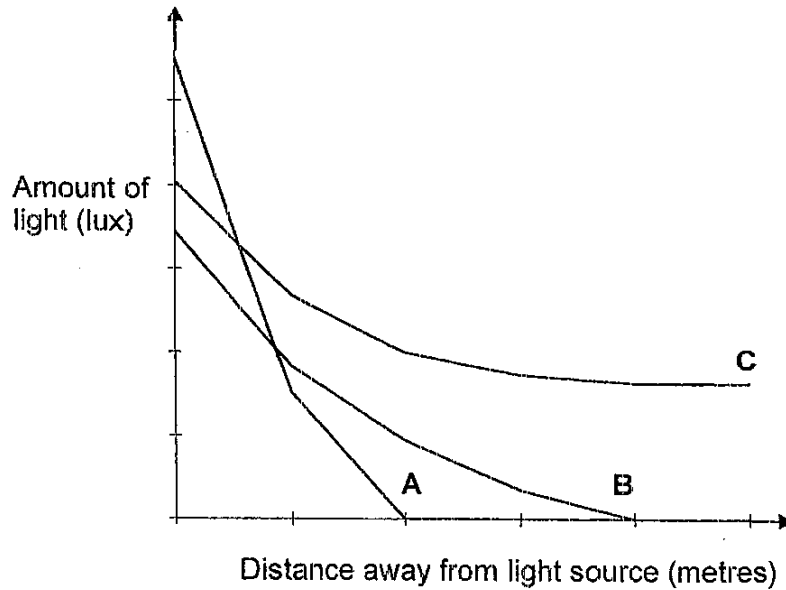

- (a) Explain why Elton should conduct his experiment in a completely dark room to ensure a fair test? [1]

Score	1
-------	---

- (b) State one other variable that should be kept constant for the experiment to be a fair one. [1]

- (c) Based on the results of his experiment, which material would be most suitable for making safety vests for motorists who travel at night? Explain your answer. [1]

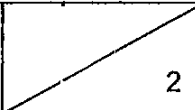
Score	
-------	---

43. Santhi conducted an experiment to study the effects of heat. She filled up a flask with coloured water and covered the opening using a stopper which has a tube in it.

She placed the flask into a basin of hot water at 90°C and observed that the coloured water rose up the tube as shown in the diagram below.

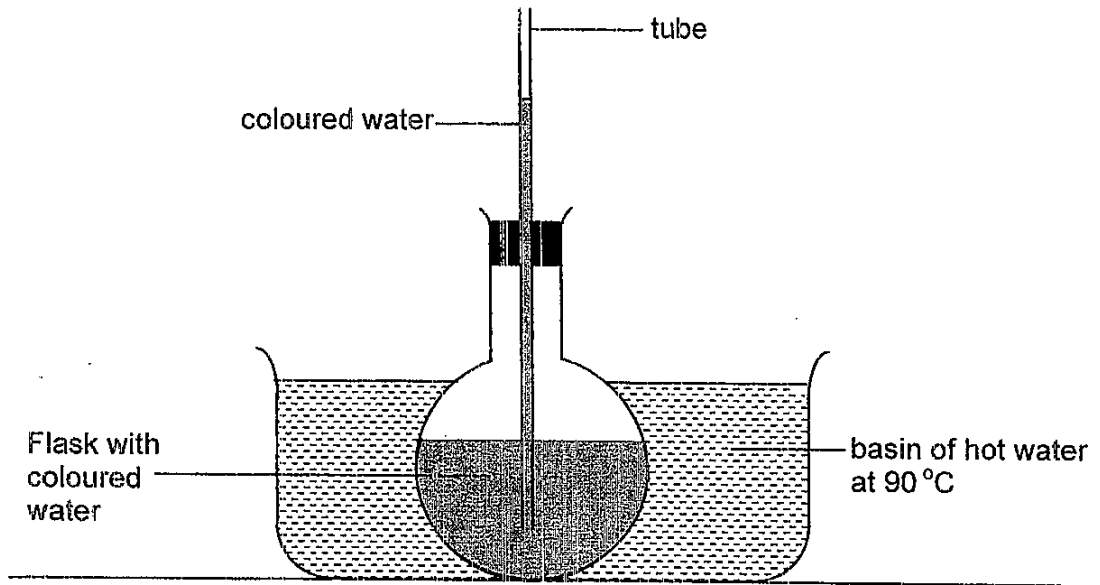

- (a) Give a reason why the coloured water rose up the tube when the flask was placed in the hot water. [1]

Score	1
-------	---

Santhi made some changes to her experimental setup. She removed the flask and replaced the hot water with cold water in the basin. She then placed an alcohol laboratory thermometer into the basin of cold water.

She observed that the level of alcohol in the thermometer dropped and she recorded a temperature of 15°C .

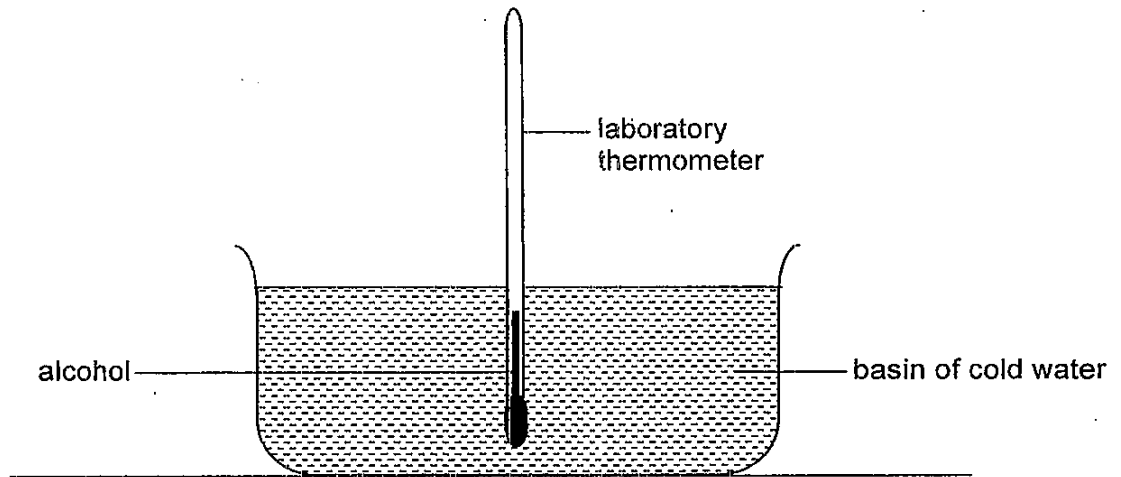

- (b) Explain why the level of alcohol dropped when Santhi used the thermometer to measure the temperature of the cold water. [2]

Score	2
-------	---

44. Four pupils set up an experiment using two identical flasks, X and Y. They placed a funnel over the opening of flask X and they poured 150ml of water into each flask X and Y at the same time with the same speed.

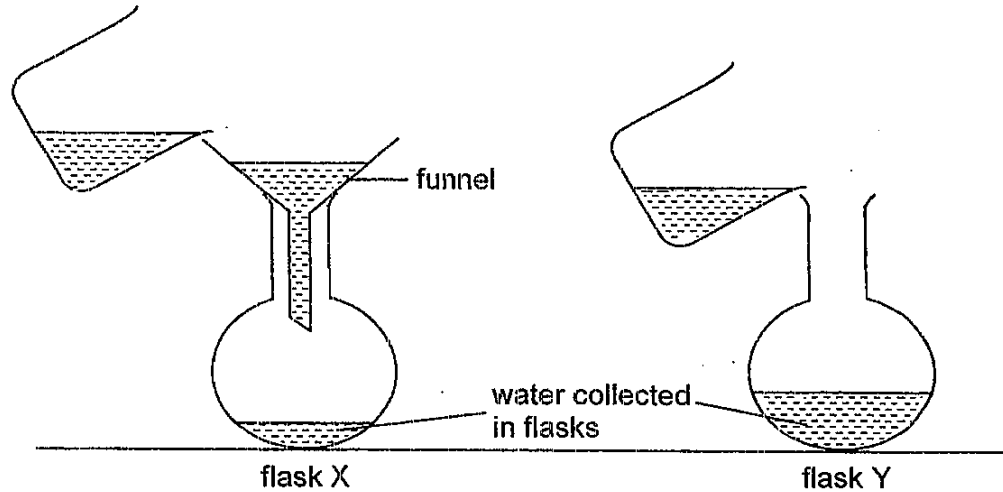

The pupils observed that flask Y filled up faster than flask X. They wrote some statements to explain their observation in the table as shown below.

Pupil 1	There is no funnel blocking the opening in flask Y so more water can be collected.
Pupil 2	Water moved in to push the air out in flask Y, so water can be poured in faster.
Pupil 3	The funnel is blocking the water from flowing into flask X. Therefore, water flowed in slower in flask X.

- (a) Pupil 4 noted that both pupils 2 and 3 have misconceptions which led to errors in their statements.

Write the correct statements which pupils 2 and 3 should make in the table provided. [2]

Pupil 2	
Pupil 3	

Another group of pupils conducted another similar experiment. They pierced a hole in a tin of condensed milk and tilted it to observe the speed at which the milk is flowing out from the tin.

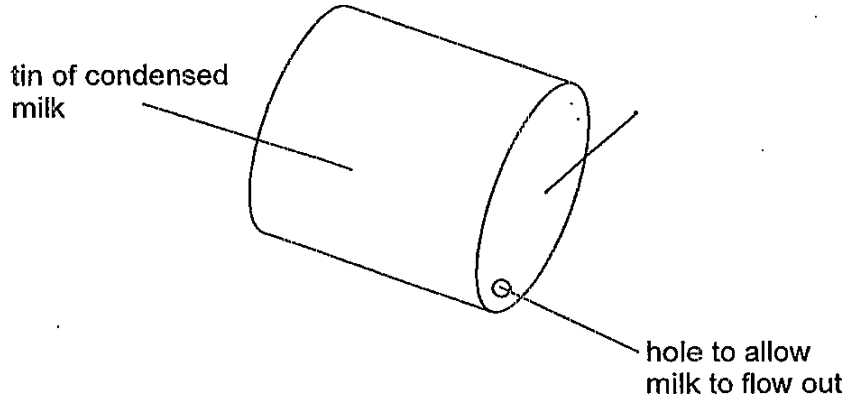

They observed that the milk flowed out slowly from the tin. One of the pupils suggested that they should pierce another hole in the tin to allow the milk to flow out faster.

- (b) Mark with an 'X' on the tin in the diagram given, to indicate where you would pierce the other hole.
Explain your decision for the position of hole marked "X" on the tin. [1]

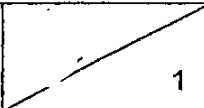
Score	
-------	---



ExamSutra 考试圣经

Answer Sheets

Nan Hua Pri 6 SA2/2010 SCIENCE

1.	4	11.	4	21.	4
2.	2	12.	2	22.	3
3.	4	13.	2	23.	4
4.	2	14.	2	24.	2
5.	3	15.	3	25.	2
6.	2	16.	1	26.	2
7.	1	17.	3	27.	3
8.	4	18.	3	28.	3
9.	4	19.	1	29.	3
10.	1	20.	3	30.	3

31a)

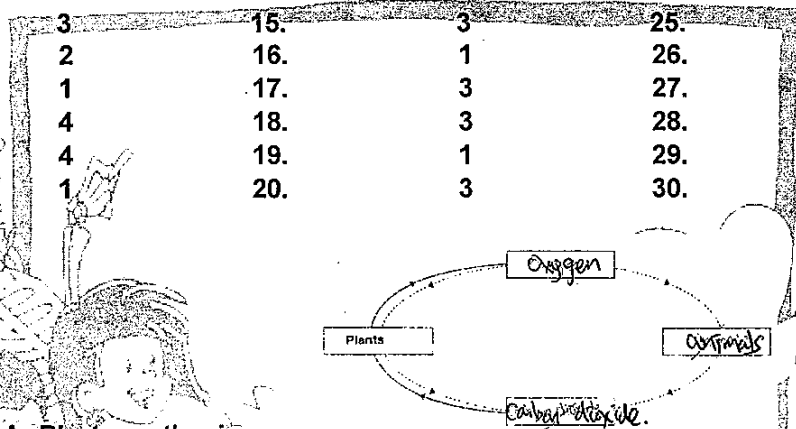

31b) Process A: Photosynthesis

31b) Process B: Respiration

32a) No, it was not. Bug A was not the predator of the aphids as the population remained the same.

32b) Bug B: Bug B fed on aphids, thus the population of aphids decreased.

32c) Bug C could have been the predator of Bug B, thus when it was introduced, the number of Bug B decrease, allowing the number of aphids to increase.

33a. There is 1 herbivore in the food web.

33b. King fishes is the predator of the great diving beetle.

33c. Duckweed → tadpole → great dividing beetle → kingfisher.

34a. The layer of air acts as a poor conductor of heat helping to reduce the rate of heat loss from the body to the cold environment.

34b. The coat is able to trap a layer of air which acts as a poor conductor of heat which reduce body heat loss.

35a. Gravity

35b. He should repeat the experiment a few times and calculate the average reading.

35c. 100g.

36a. Point 3 b. Points 1 and 5

36c. i. gravitational potential energy ii. kinetic energy

37. 1000m as the surrounding is dark and the light that it emits will be able to attract its prey.

38a. Clover, oats and sunflower.

38b. yes, I agree if the field mouse eats the spider, it would have less energy available compared to eating the sunflower as some of the energy is used up by the grasshopper and the spider for life process.

39a. The seaweeds and sponges on its back help to camouflage the crab in its environment; hence the crab will not be easily spotted.

39b. The poisonous sharp spines of the sea urchin will help to protect the crab from its predators.

40a. The sugar provide food to keep the bacteria alive

40b. It is to kill the unwanted bacteria in the milky solution

40c. 37°C

41a. disadvantage 1: All the bulbs are controlled by one switch. Lamps cannot be controlled independently

disadvantage 2: If bulb 'a' fuses, there would be an open circuit and the rest of the bulbs would not light up

41b.

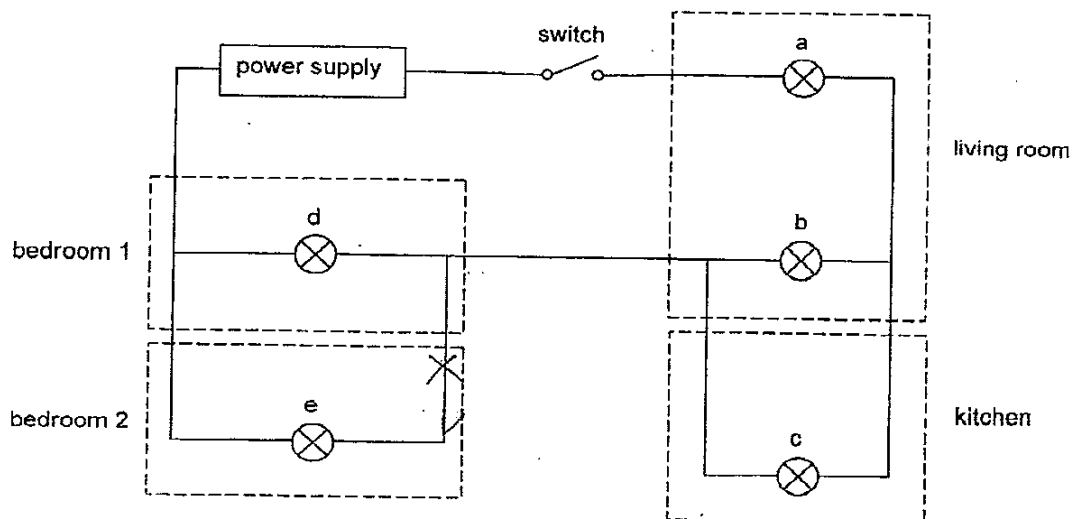



42a. To ensure that the light source does not deflect other sources of the light.

42b. The intensity of the light source.

42c. Material C. When A, B and C are placed at the same distance away from the light source, C reflected the most amount of light.

Material C. It is able to reflect light from the furthest distance away from the light source.

43a. The colored water in the glass gained heat from the hot water and expanded.

43b. The alcohol in the laboratory thermometer lost heat to the cold water in the basin, thus contracting and dropping to the temperature of 15°C .

44a. Pupil 2: Air in flask Y can escape through the opening hence allow water to enter easily to occupy its space.

Pupil 3: The air in flask X cannot escape as the funnel is blocking the opening, hence water cannot easily occupy its space.

44b.

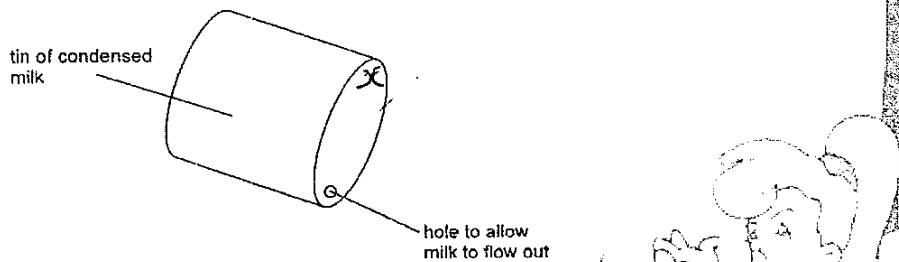

When the milk in the tin flows out of the bottom hole, air can enter from the top hole to occupy the space.

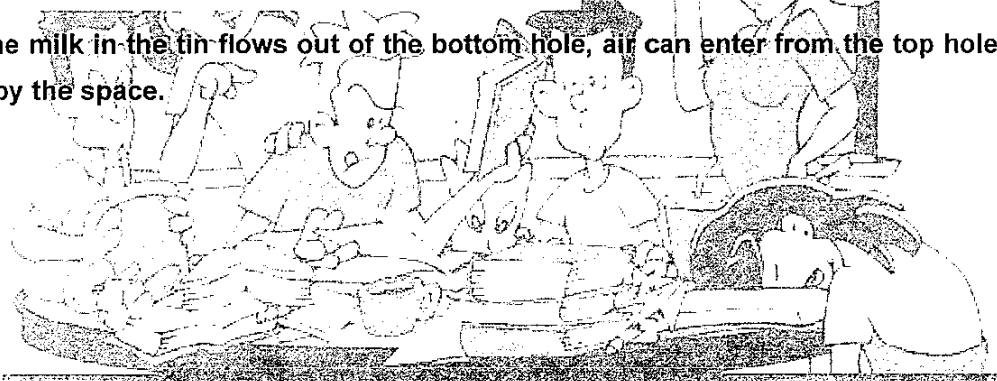

examstutra@yahoo.com.sg

