



Anglo-Chinese School (Junior)  
Anglo-Chinese School (Primary)

**PRELIMINARY EXAMINATION 2017  
PRIMARY SIX  
SCIENCE  
BOOKLET A**

Name: \_\_\_\_\_ ( )

Class: Primary 6 \_\_\_\_\_

Date: 25 August 2017

Duration of paper: 1 h 45 min

**INSTRUCTIONS TO CANDIDATES**

1. Write your name, register number and class.
2. Do not turn over this page until you are told to do so.
3. Follow all instructions carefully.
4. Answer all questions.
5. Shade your answer on the Optical Answer Sheet (OAS) provided.
6. This question paper consists of 22 printed pages including this cover page.



**PART I**

For each question from 1 to 28, four options are given. One of them is the correct answer. Make your choice (1, 2, 3 or 4) and shade your answer on the Optical Answer Sheet.

(56 marks)

- 1 Tom had four magnets, W, X, Y and Z, suspended on strings above a box of thumbtacks as shown in the diagram below. All the magnets were placed at an equal distance away from the thumbtacks.

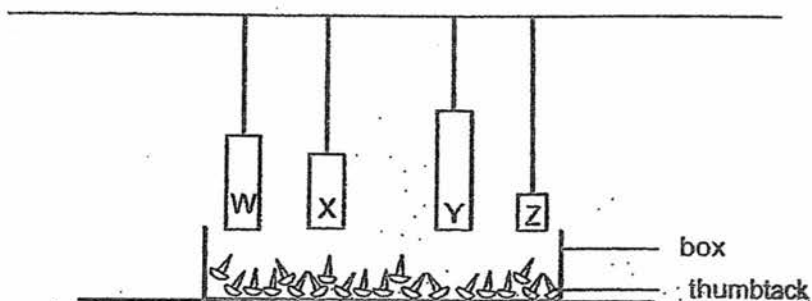

He observed the number of thumbtacks that each magnet was able to attract and recorded his findings in the table below.

Magnet	W	X	Y	Z
Number of thumbtacks attracted	3	2	5	6

Which two statements could he infer from the experiment and the results in the table?

- A Magnetic force can act from a distance.
  - B Shorter magnets are weaker than longer magnets.
  - C The strength of a magnet is not dependent on its size.
  - D The strength of a magnet can be reduced by dropping the magnet.
- (1) A and B  
 (2) B and D  
 (3) C and D  
 (4) A and C

(Go on to the next page)

- 2 The table below shows the changes in weather conditions from Monday to Thursday. On which day would wet clothes that are hung out to dry take the longest time to dry?

	Day	Sunny	Windy	Surrounding Temperature
(1)	Monday	Yes	No	33°C
(2)	Tuesday	No	No	28°C
(3)	Wednesday	Yes	Yes	33°C
(4)	Thursday	No	Yes	28°C

- 3 Which two of the following are characteristics that can be passed from parents to their young?

- A Thumbprints
  - B Length of hair
  - C Colour of eyes
  - D Ability to roll the tongue
- (1) A and B
- (2) B and D
- (3) C and D
- (4) A and C

(Go on to the next page)

- 4 Jack used a magnet to stroke a steel bar XY repeatedly as shown in Diagram 1 below. Diagram 2 shows the magnetic poles of the steel bar after it was magnetized.

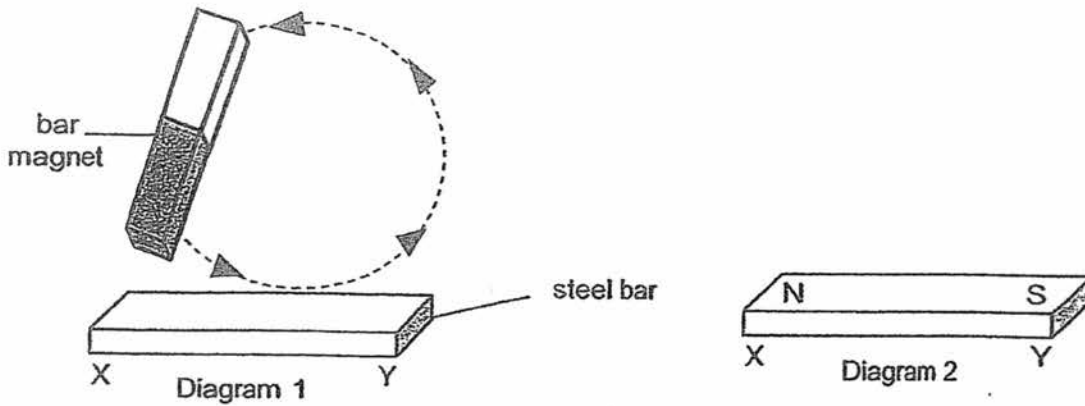

Jack then brought a compass near the steel bar XY as shown in Diagram 3 below.

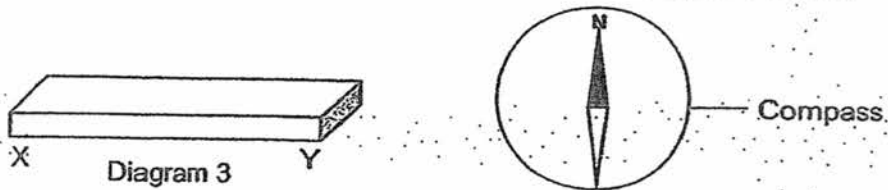

Which of the following are possible observations?

	Possible Observation	
A		
B		
C		
D		

- (1) B only
- (2) B and C only
- (3) C and D only
- (4) A, B and D only

(Go on to the next page)

5 The flowchart below shows how matter is classified.

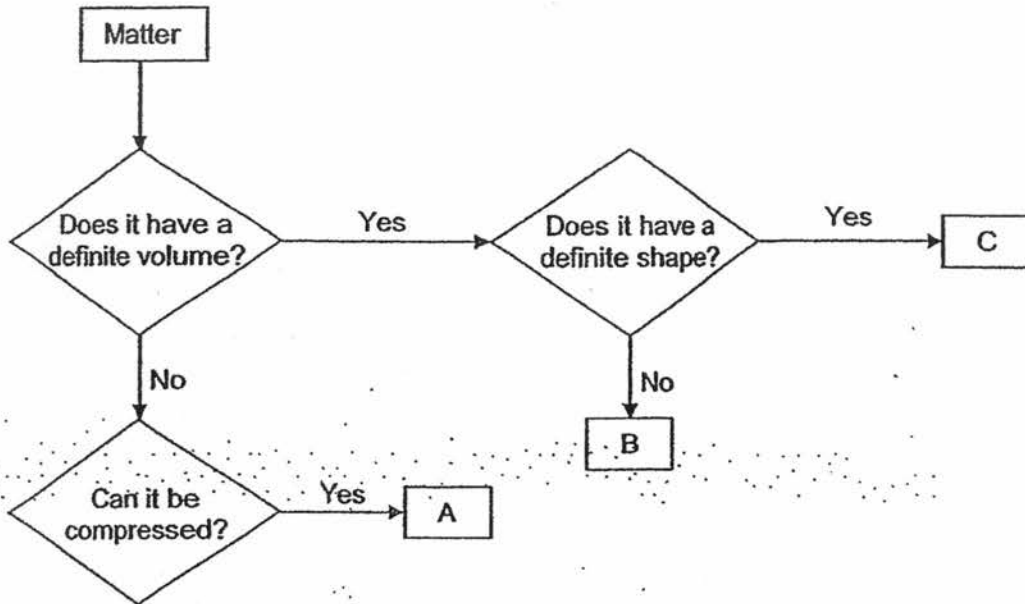

What can A, B and C most likely be?

	A	B	C
(1)	Gas	Solid	Liquid
(2)	Solid	Liquid	Gas
(3)	Liquid	Gas	Solid
(4)	Gas	Liquid	Solid

(Go on to the next page)

- 6 Sally was walking along the bank of a river and observed some plants growing in a particular pattern. She made a diagram of her observations as shown below.

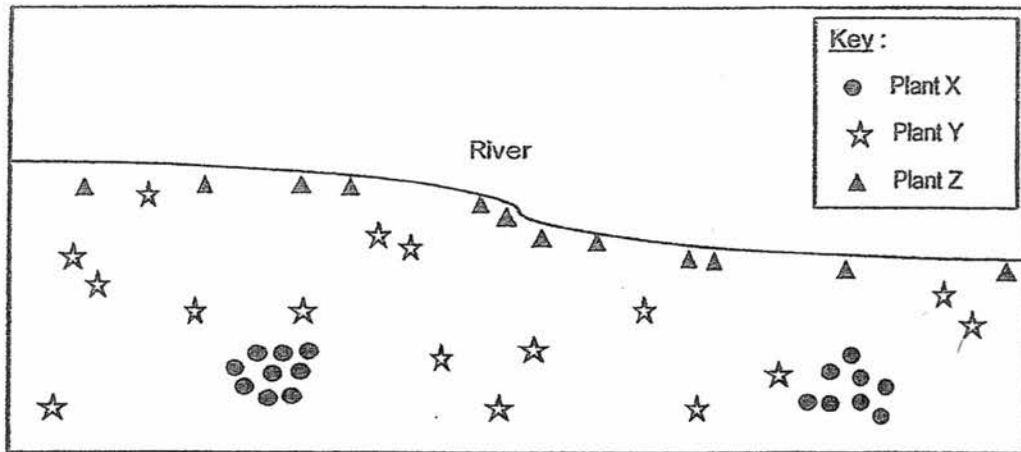

Which of the following best represents the method of seed dispersal of the three plants, X, Y and Z?

	Plant X	Plant Y	Plant Z
(1)	Wind	Animal	Splitting
(2)	Splitting	Water	Animal
(3)	Water	Wind	Splitting
(4)	Splitting	Animal	Water

- 7 The diagram below shows the growth of a bean plant.

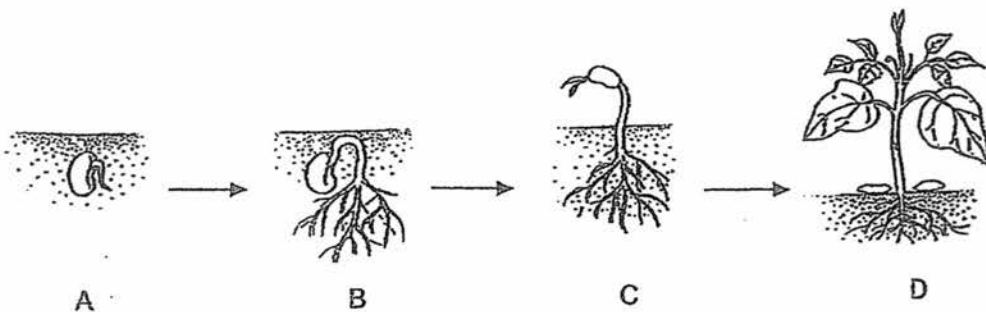

At which stage(s) is sunlight needed for the growth of the plant?

- (1) D only  
 (2) B and C only  
 (3) A, B and C only  
 (4) A, B, C and D

(Go on to the next page)

- 8 In the diagram below, A, B, C, D and E represent different processes that result in the changes in states of water.

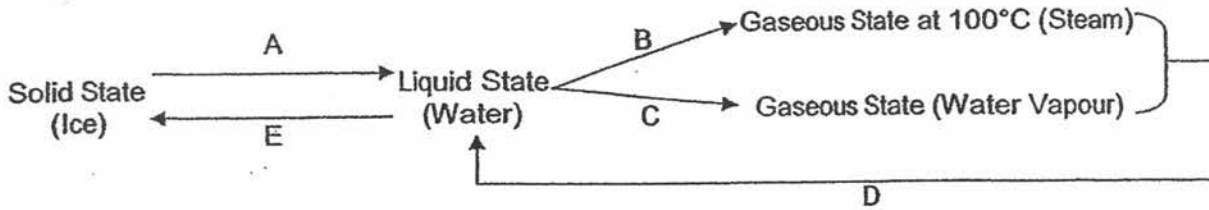

Which of the following processes correctly represent A, B, C, D and E?

	A	B	C	D	E
(1)	Freezing	Evaporation	Boiling	Condensation	Melting
(2)	Melting	Boiling	Evaporation	Condensation	Freezing
(3)	Freezing	Evaporation	Condensation	Boiling	Melting
(4)	Melting	Boiling	Condensation	Evaporation	Freezing

- 9 The diagrams below show forces, F1, F2 and F3, exerted on two identical blocks, X and Y, at the same time on the same surface.

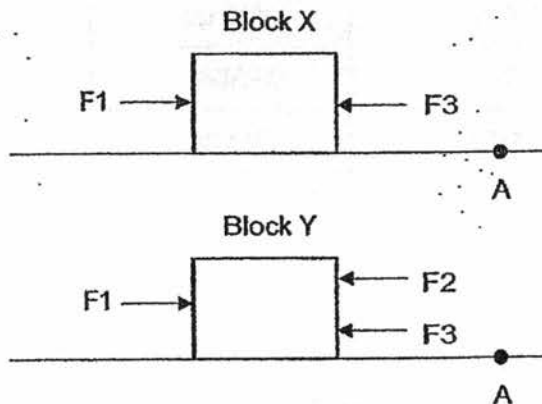

Which of the following shows the correct amount of forces for F1, F2 and F3 such that Block X will move to point A while Block Y remains stationary?

	F1 (units)	F2 (units)	F3 (units)
(1)	10	20	30
(2)	20	20	10
(3)	20	10	20
(4)	30	20	10

(Go on to the next page)



- 10 Jacob taped an inflated balloon to a straw as shown below. When he released the balloon, air rushed out from the balloon and produced a force.

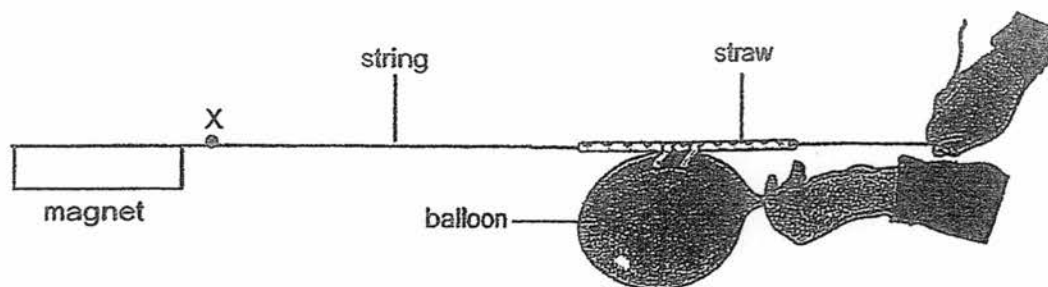

The balloon attached to the straw moved along the string towards point X as the force produced was greater than the \_\_\_\_\_ force acting on the straw.

- A frictional
- B magnetic
- C elastic spring

- (1) A only
- (2) A and C only
- (3) B and C only
- (4) A, B and C

(Go on to the next page)

- 11 Mike carried out an experiment to find out the preferred environment of organism H. 20 organisms H were placed in the middle of Dish X. After 10 minutes, the number of organism H in each section of Dish X was counted.

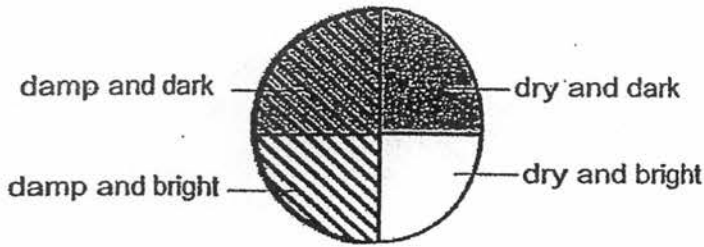

Dish X

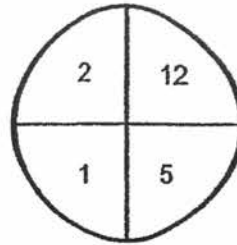

Number of organism H in each section after 10 minutes

He repeated the experiment with the same number of organism H placed in the middle of Dish Y and Dish Z.

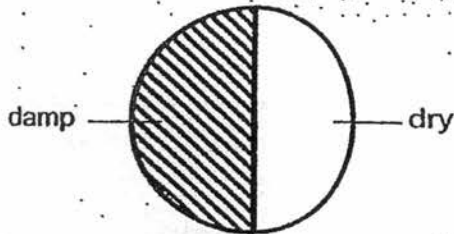

Dish Y

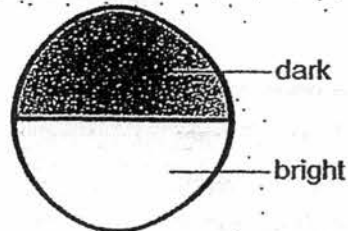

Dish Z

Which of the following correctly shows the likely number of organism H in each section of Dish Y and Z?

Number of organism H in each section				
Dish Y		Dish Z		
	damp	dry	dark	bright
(1)	10	10	8	12
(2)	4	16	16	4
(3)	12	8	17	3
(4)	9	11	10	10

(Go on to the next page)

- 12 Study the food web below.

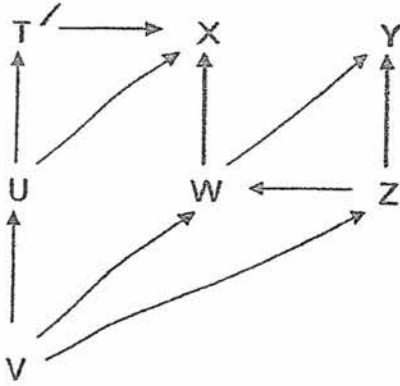

Which of the organisms are both prey and predator?

- (1) X and Y only
  - (2) T and W only
  - (3) T, X and Y only
  - (4) T, U, W, X, Y and Z only
- 13 The government was concerned that polluted water was being washed into the rivers.

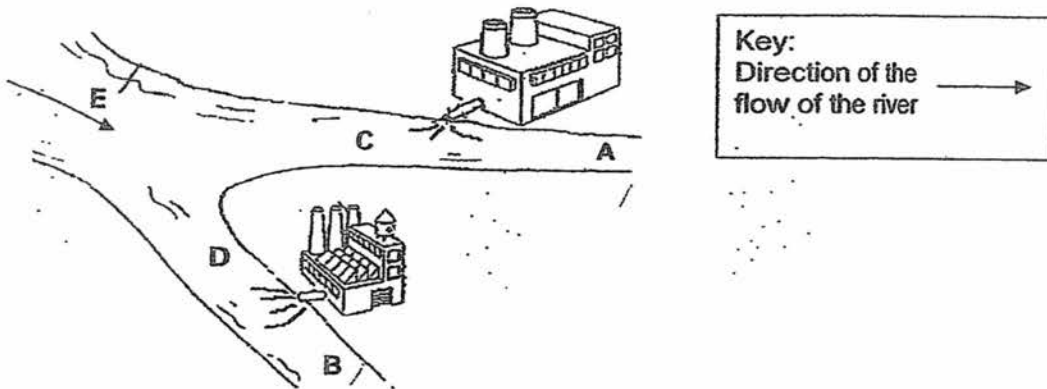

In order to pinpoint the sources of pollution, the government collected and tested water samples from different parts of the river. Which samples does the government have to test and compare?

- (1) A and B only
- (2) C and D only
- (3) A, B and E only
- (4) C, D and E only

(Go on to the next page)

- 14 The diagram below shows Animal L, a nocturnal mammal, and its special adaptations in order to survive in its natural environment. Animal L only feeds on plants.

Large eyes, good night vision

A toxic bite



Covers her baby in poisonous saliva by licking the toxin onto its baby's fur before heading off to ~~hunt~~ to find food

Pincer-like hands and feet

The chart below shows how the adaptations stated above could be classified.

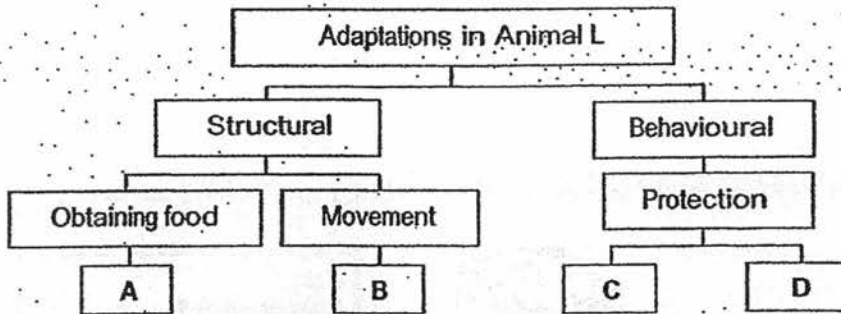

Which one of the following correctly matches A, B, C and D in the flowchart of Animal L?

	A	B	C	D
(1)	Pincer-like hands and feet	Covers her baby in poisonous saliva	Large eyes, good night vision	A toxic bite
(2)	Pincer-like hands and feet	Large eyes, good night vision	A toxic bite	Covers her baby in poisonous saliva
(3)	A toxic bite	Pincer-like hands and feet	Covers her baby in poisonous saliva	Large eyes, good night vision
(4)	Pincer-like hands and feet	A toxic bite	Large eyes, good night vision	Covers her baby in poisonous saliva

(Go on to the next page)

15 The diagram below shows the direction of blood flow in the human body.

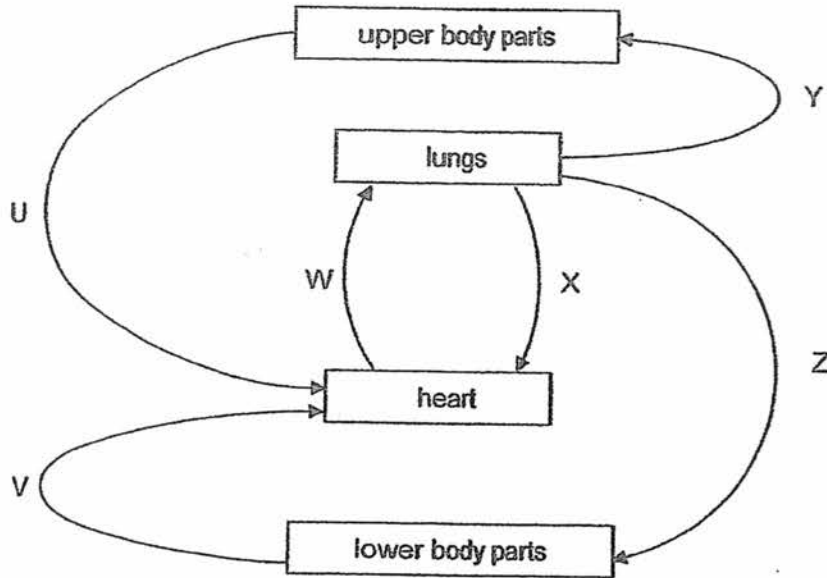

Which two arrows in the diagram above are not correct?

- (1) U and V
- (2) U and Z
- (3) W and X
- (4) Y and Z

16 Ali placed four identical pieces of bread in four jars which were exposed to different conditions as shown in the diagram below. All four jars were sealed tightly.

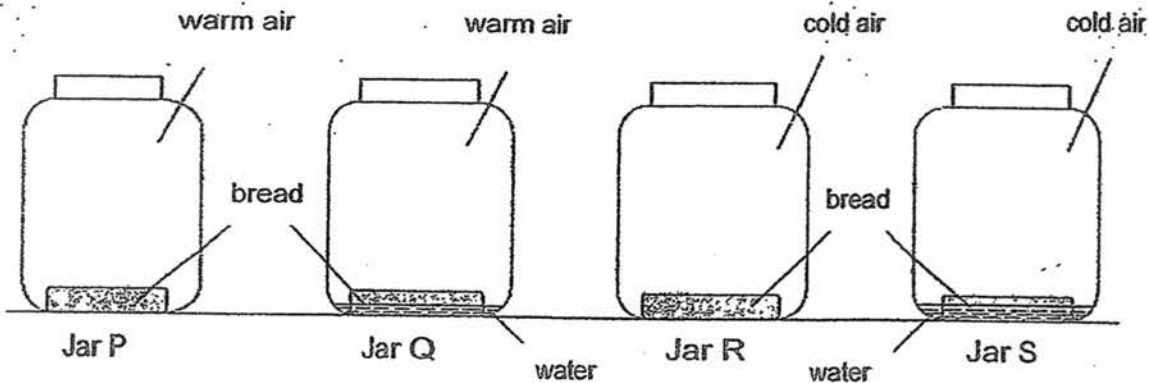

After five days, he observed each of the bread in the jars. Which jar would most likely contain bread which had turned mouldy first?

- (1) P
- (2) Q
- (3) R
- (4) S

(Go on to the next page)

17 The diagram below shows a flowering plant.

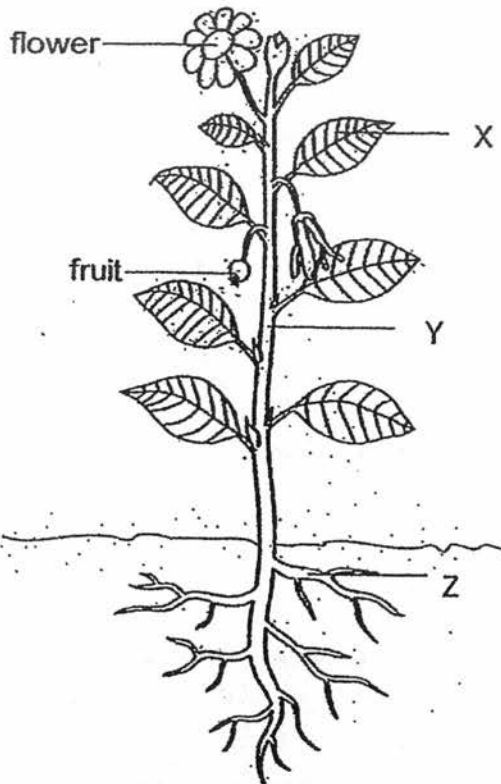

What are the functions of the parts labelled X, Y and Z?

	Part X	Part Y	Part Z
(1)	To make food for the plant	To take in sunlight for the plant	To transport food to the leaf
(2)	To grow into a new plant	To grow into a fruit	To absorb sunlight for the plant
(3)	To make food for the plant	To hold the plant upright	To absorb water for the plant
(4)	To absorb water for the plant	To store seeds for the plant	To grow into a flower

(Go on to the next page)

- 18 A soccer ball was placed under two lamps as shown below.



Which one of the following pictures below correctly shows the shadow(s) cast by the soccer ball?

(1)



(2)



(3)



(4)



(Go on to the next page)

19 Study the diagram below.

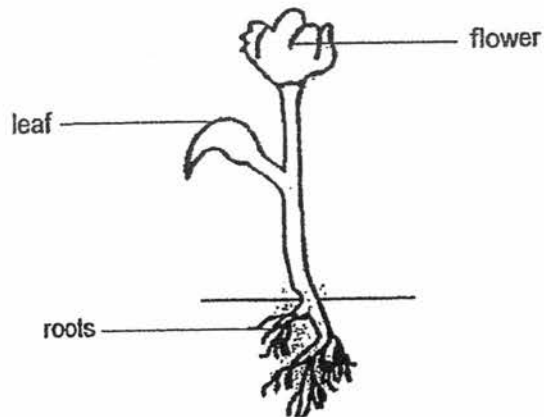

Which diagram shows the correct movement of food in a plant with flower?

(1)

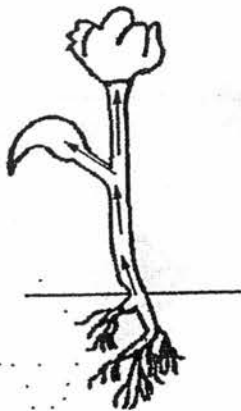

(2)

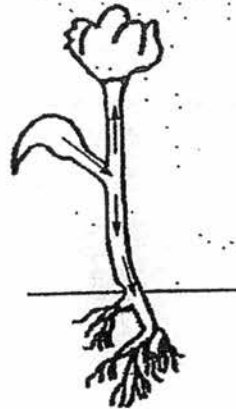

(3)

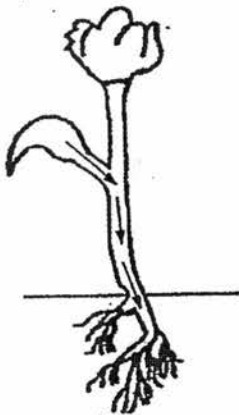

(4)

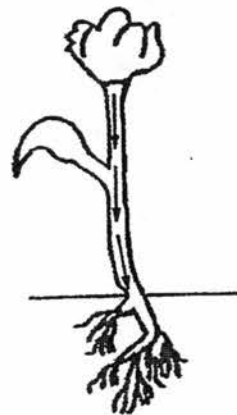

(Go on to the next page)



- 20 Kumar conducted an experiment using the following set-ups. They were placed next to an open window during the day for a few hours.

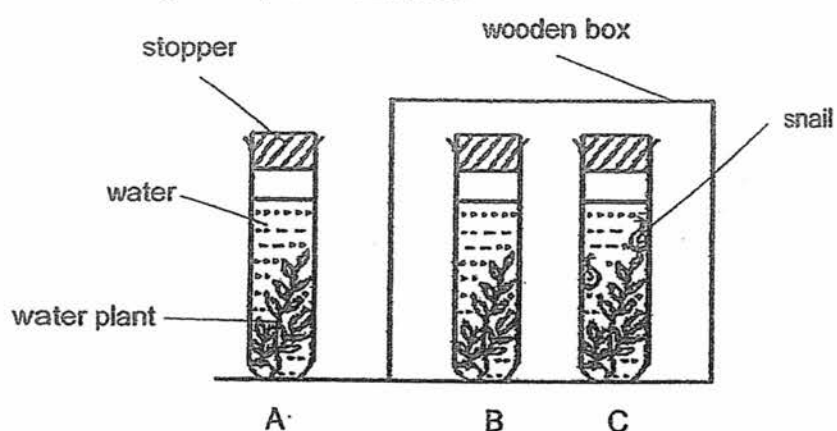

What would be the likely change in the amount of carbon dioxide at the end of the experiment?

Amount of carbon dioxide in set-up			
	A	B	C
(1)	increase	increase	no change
(2)	decrease	increase	no change
(3)	increase	decrease	decrease
(4)	decrease	increase	increase

(Go on to the next page)

- 21 The diagram below shows a plant cell.

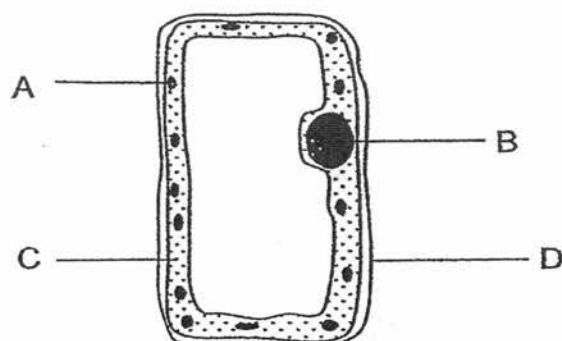

Four pupils made the following statements about the plant cell.

Alex: Part A traps light to make food.

Bala: Part B controls all activities of the cell.

Chloe: Part C controls the movement of substances in and out of the cell.

Danny: Part D protects the cells by preventing harmful substances from entering.

Which pupils were correct?

- (1) Alex and Bala only
- (2) Alex and Chloe only
- (3) Bala, Chloe and Danny only
- (4) Alex, Chloe and Danny only

- 22 The circuits below have an iron rod, a wooden rod and a plastic rod as components of each circuit.

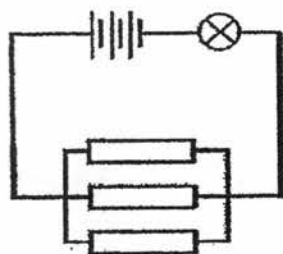

circuit A

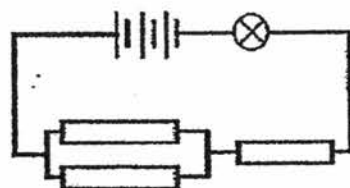

circuit B

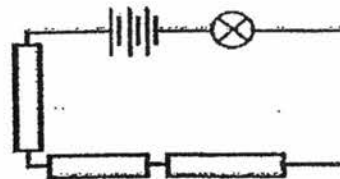

circuit C

The bulbs and the batteries in the three electric circuits are identical and in working conditions. In which of the above circuits would the bulb light up?

- (1) A only
- (2) C only
- (3) A and B only
- (4) None of the above circuits

(Go on to the next page)

23 In the four circuits, all the bulbs and batteries are new and identical.

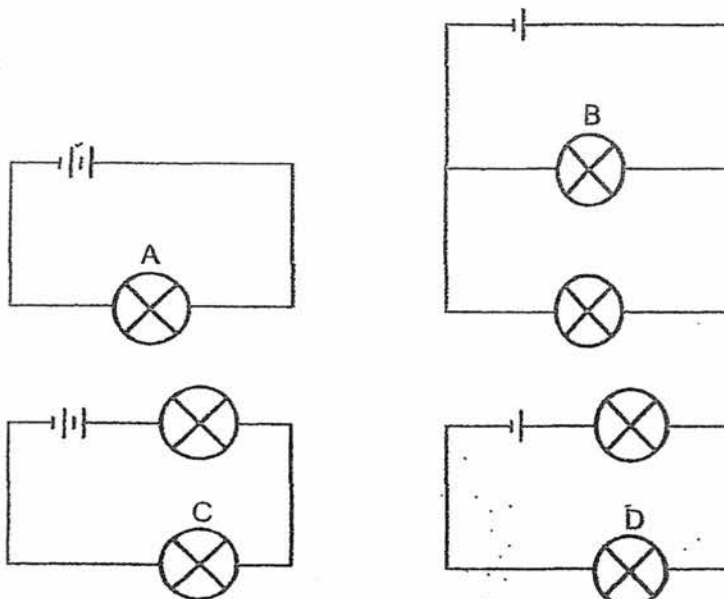

Which of the following two bulbs have the same brightness?

- (1) A and D
- (2) B and C
- (3) B and D
- (4) C and D

(Go on to the next page)

- 24 Audrey filled up half a beaker with ice and heated it until all the ice had melted. She noticed that it took all the ice 10 minutes to completely melt. She then heated the water until it started boiling. She noted that it took another 20 minutes for the water to start boiling.

Which one of the following graphs best shows the change in temperature in the beaker that Audrey observed?

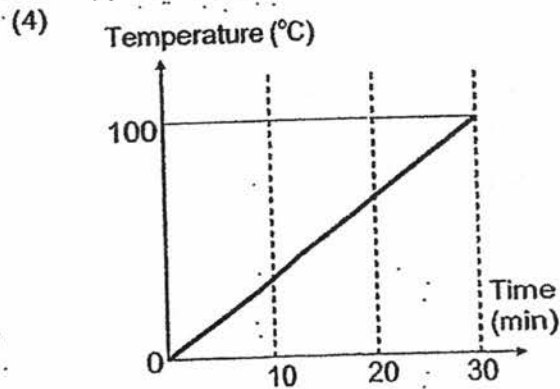
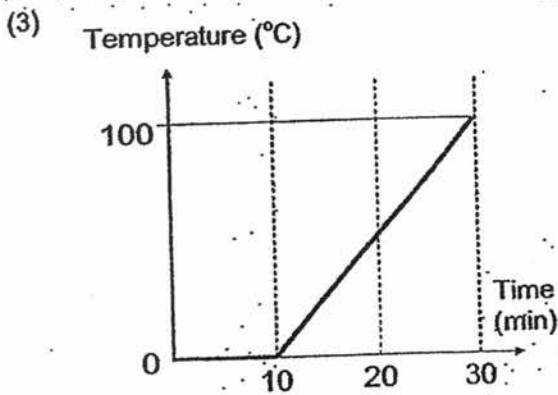
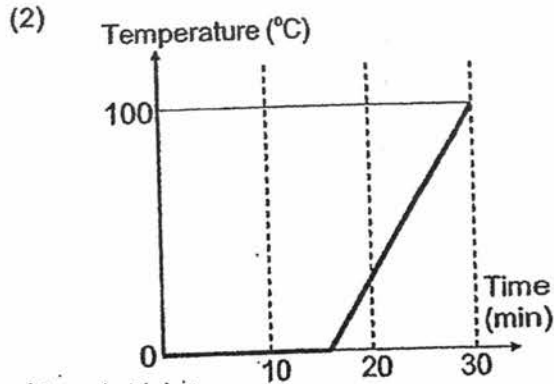
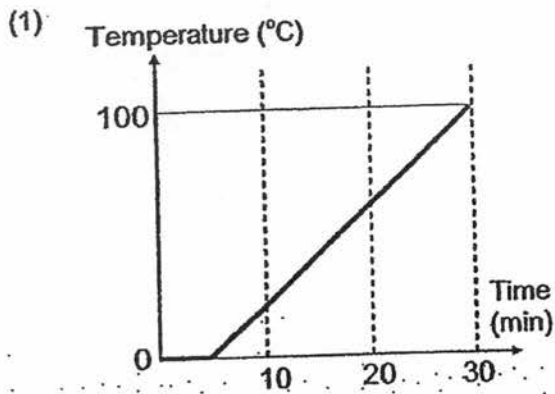

(Go on to the next page)

25 Eddie set up an experiment as shown below.

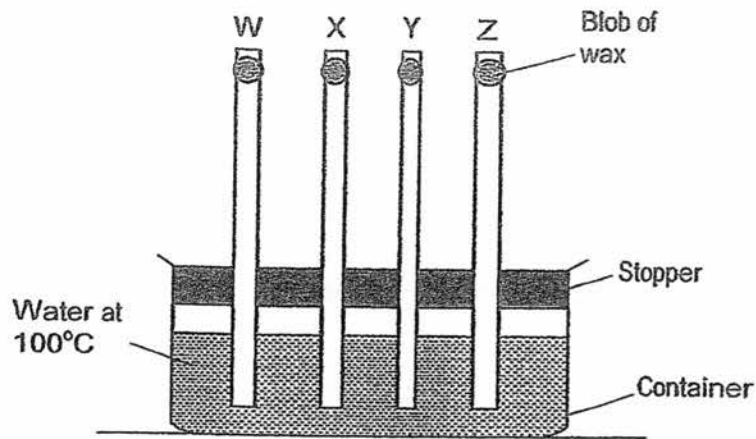

All the rods were of the same size, but made of different materials. He placed the same amount of wax on the tip of each rod and poured in boiling water into the container as shown above. He started to measure and record the time taken for all the wax on rods, W, X, Y and Z to melt. He plotted his results in a graph below.

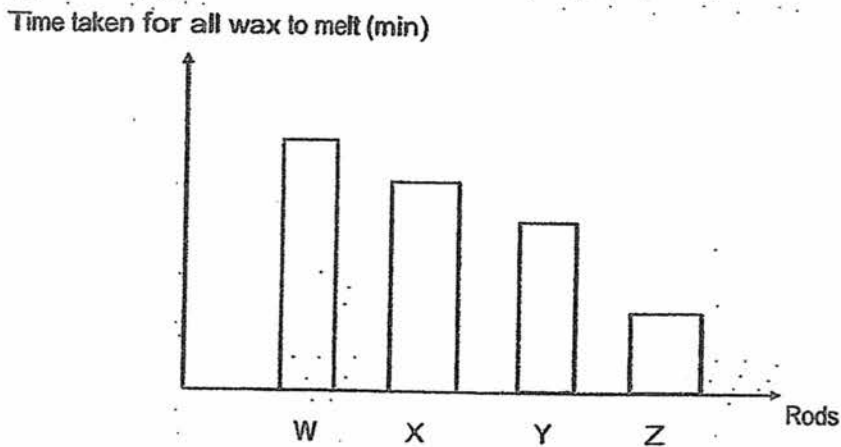

Which one of the rods is made of a material that is the most suitable for making boxes to store ice-cream so that the ice-cream will take the longest time to melt?

- (1) Rod W
- (2) Rod X
- (3) Rod Y
- (4) Rod Z

(Go on to the next page)

- 26 Boon Hui heated 200 ml of water in two beakers, X and Y, until the water boiled. The graph below shows the changes in the temperature of the water in both beakers.

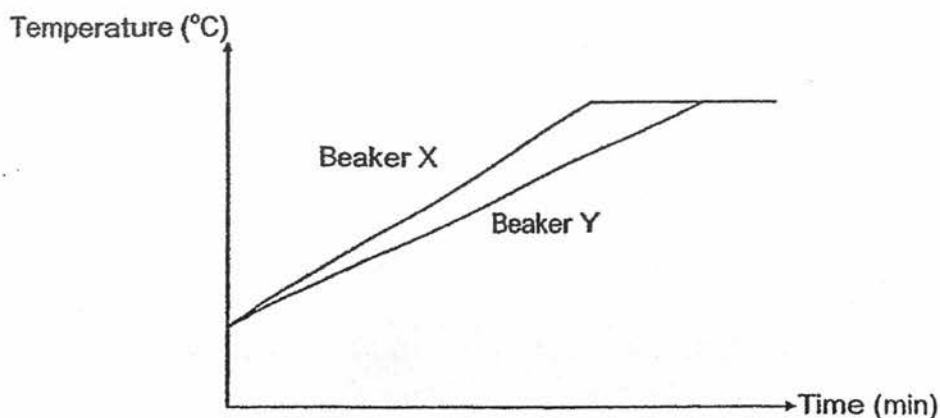

Which of the following statements is/are possible reason(s) to explain the results shown above?

- A Beaker X is a better heat conductor than beaker Y.
- B Beaker Y has a larger contact surface area with the heat source.
- C Boon Hui used a stronger heat source to heat up the water in beaker X.

- (1) A only
- (2) B only
- (3) A and C only
- (4) B and C only

27. Which of the following best represents the source of energy, its application and the main type of energy produced?

	Source of energy	Used for/in	Main type of energy produced
A	Sun	Photosynthesis	Chemical potential
B	Coal	Power stations	Gravitational potential
C	Battery	A radio	Sound
D	Food	A person swimming	Kinetic

- (1) A and D only
- (2) B and C only
- (3) A, B and D only
- (4) A, C and D only

(Go on to the next page)

- 28 Betty had some plants of the same type as shown below. She wanted to find out how the number of part P will affect the mass of the plant over a period of time.

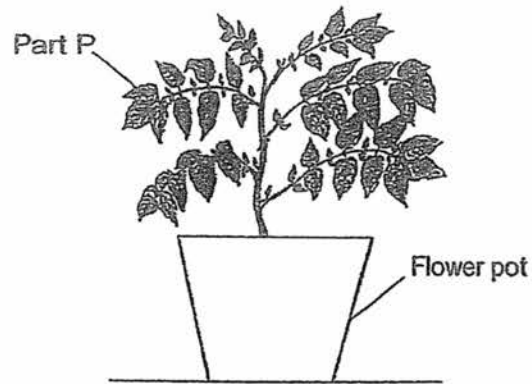

Which of the following variables should Betty keep the same so that her investigation is a fair one?

- A Number of Part P
  - B Amount of water given
  - C Amount of sunlight available
  - D Amount of nutrients available
- (1) A and C only
- (2) B and D only
- (3) B, C and D only
- (4) A, B, C and D

(Go on to booklet B)







Anglo-Chinese School (Junior)  
Anglo-Chinese School (Primary)

PRELIMINARY EXAMINATION 2017  
PRIMARY SIX  
SCIENCE  
BOOKLET B

Name: \_\_\_\_\_ ( ) Class: Primary 6 \_\_\_\_

Date: 25 August 2017

Duration of paper: 1 h 45 min

\_\_\_\_\_  
Parent's/Guardian's Signature

**INSTRUCTIONS TO CANDIDATES**

1. Write your name, register number and class.
2. Do not turn this page until you are told to do so.
3. Follow all instructions carefully.
4. Answer all questions.
5. Write your answers in this booklet.
6. This question paper consists of 15 printed pages including this cover page.

BOOKLET	POSSIBLE MARKS	MARKS OBTAINED
A	56	
B	44	
Total	100	

**PART II**

For questions 29 to 40, write your answers in this booklet.

The number of marks available is shown in brackets [ ] at the end of each question or part question.

(44 marks)

- 29 Tessa set up an experiment as shown below. When she closed the switch of the electric circuit, she observed that object X rose up and was suspended at a height of  $h$  cm from the bottom of the glass container.

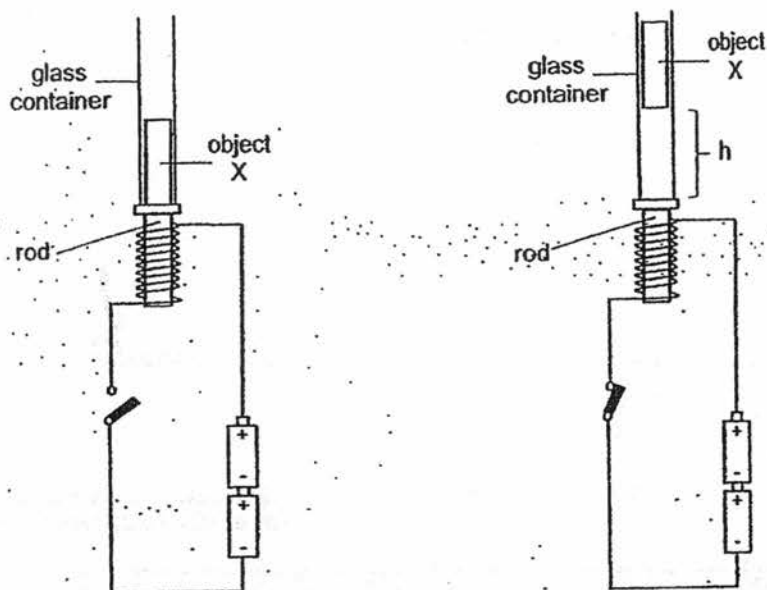

- (a) From the results of her experiment, what could Tessa infer about object X? [1]
- \_\_\_\_\_
- (b) Explain clearly how object X could suspend from a height of  $h$  cm from the bottom of the glass container when Tessa closed the switch of the electric circuit. [2]
- \_\_\_\_\_
- \_\_\_\_\_
- \_\_\_\_\_
- (c) Without changing object X, suggest two changes that Tessa can make to the set-up of her experiment to increase the value of  $h$  when she closes the switch of the electric circuit. [2]
- \_\_\_\_\_
- \_\_\_\_\_

(Go on to the next page)

SCORE	5
-------	---

30 The diagrams below show the life cycles of two organisms P and Q.

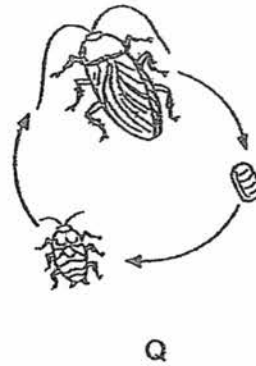
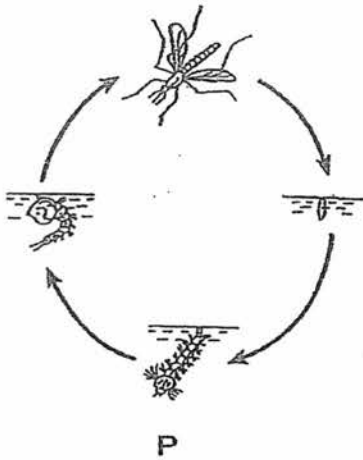

(a) State one similarity and one difference based on what you can observe about the life cycles of organisms P and Q as shown above. [2]

Similarity :

---



---

Difference :

---



---

(b) At which stage in organism P's life cycle can it potentially spread diseases and be harmful to humans? Suggest a way to prevent organism P from reproducing in your home and explain clearly how your suggestion works. [1]

---



---

(Go on to the next page)

SCORE	
	3

- 31 Calvin conducted an experiment to find out where tiny water droplets form on the two identical glasses of milk at two different temperatures as shown in the diagram below. He placed the two glasses of milk on the table in a room at  $30^{\circ}\text{C}$  for 10 minutes.

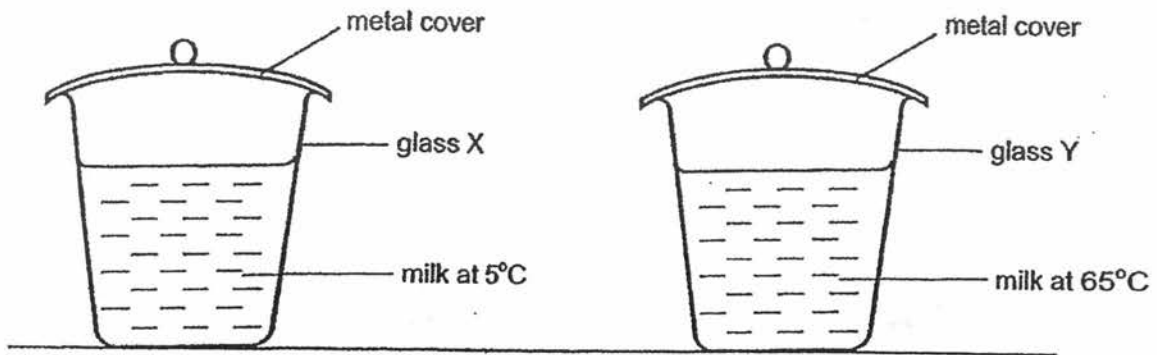

- (a) Predict specifically where the water droplets would form on the two glasses/set-ups after 10 minutes. [2]

Glass X:

---

Glass Y:

---

- (b) Explain how the water droplets are formed in Glass Y. [2]

---



---



---

- (c) Will there be more, less or the same amount of tiny water droplets formed if the metal cover for glass Y is replaced with a plastic cover? Explain your answer. [1]

---



---

(Go on to the next page)

SCORE	
	5

- 32 Bird X lives along the seashore. It builds nests of brown twigs on the ground. It lays eggs that are light brown and covered with darker brown spots. However, the inner side of the eggshell is white.

It picks up the eggshells shortly after a chick has hatched and flies to carry the shells to a location far from the nest.

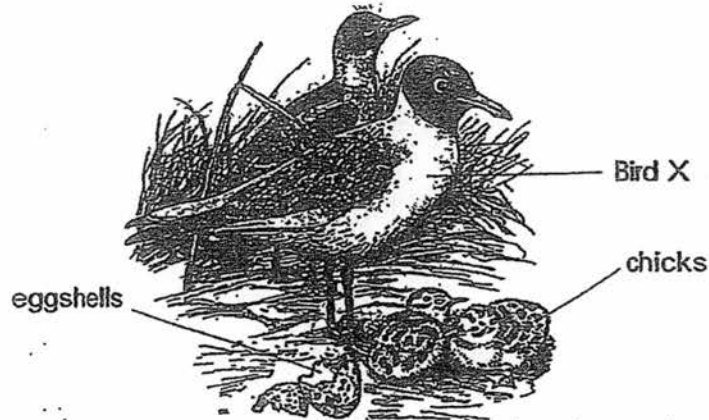

- (a) Explain why Bird X removes the eggshells from the nest. [2]

---



---



---

- (b) In the winter, Bird X migrates to warmer areas and makes its home near wetlands, coasts, and rivers. Other than to avoid the low temperature, give a reason for the migration. [1]

---



---

(Go on to the next page)

SCORE	3
-------	---

33 The diagram below shows the cutting down of trees.

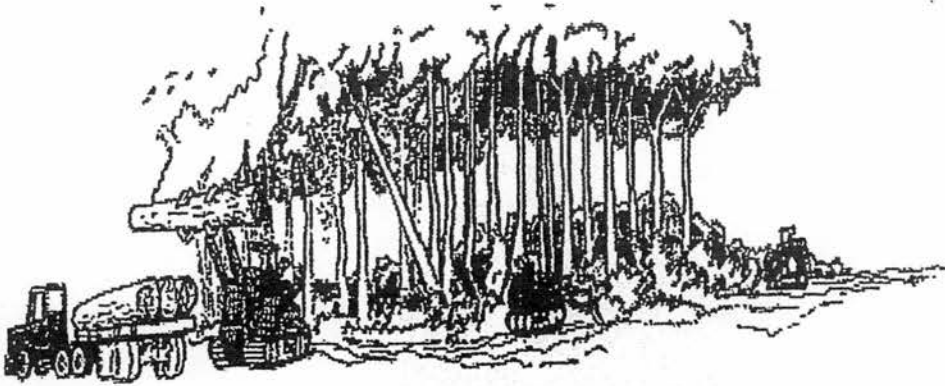

- (a) The cutting down of trees on a large scale is known as deforestation. Explain how fully submerged plants in the nearby rivers will be affected when it rains heavily. [2]

---

---

---

---

- (b) Explain how cutting down of trees can lead to an increase in the Earth's temperature. [1]

---

---

---

(Go on to the next page)

SCORE	
	3

- 34 Andre uses his finger to flick the striker from point A to point B.

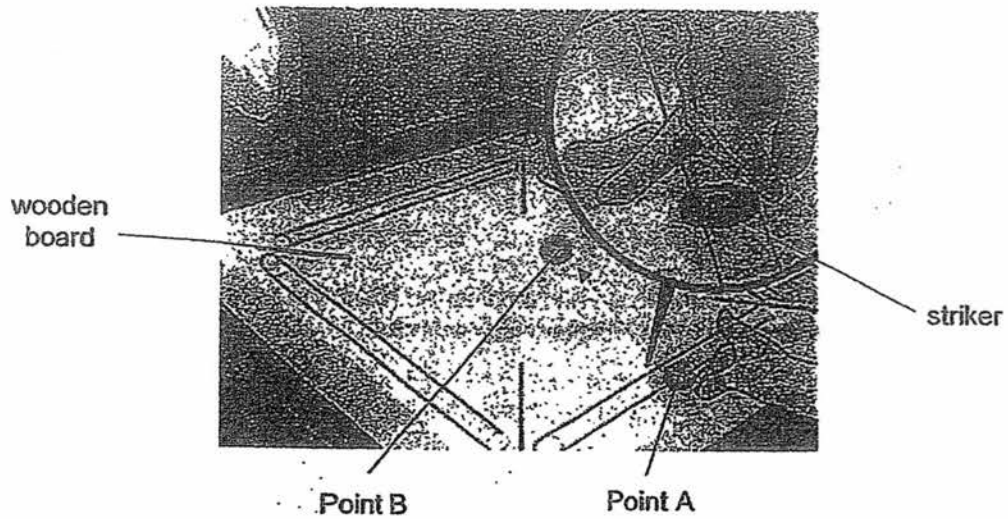

- (a) State the force(s) that is/are acting on the striker as it moves from point A to point B. [1]

---

- (b) Without moving or changing the surface of the wooden board, what can Andre do to the board if he wants the striker to move further than point B using the same amount of force to push the striker? Explain your answer. [2]

---



---



---

(Go on to the next page)

SCORE	
	3

- 35 Sarah used two identical cups as shown in the diagram below, one made of metal and the other made of styrofoam to conduct an experiment.



metal cup



styrofoam cup

- (a) She placed both cups in an air-conditioned room for an hour. Which cup felt colder when she touched them? Explain your answer. [2]

---



---



---



---

Sarah conducted another experiment in an open field using the two cups. She placed two identical ice-cubes, A and B, into each cup. The table below shows the volume of water in the two cups at the start and at the end of the experiment 10 minutes later.

	Volume of water with ice-cube A (cm <sup>3</sup> )	Volume of water with ice-cube B (cm <sup>3</sup> )
Start of the experiment	0	0
10 minutes later	40	15

- (b) Which of the ice-cubes, A or B, was placed in the metal cup? Explain your answer. [1]

---



---



---

(Go on to the next page)

SCORE	3
-------	---



- 36 Two similar water plants, A and B, were placed in identical beakers with the same volume of water and under direct sunlight. Plant A was placed in clean water while plant B was placed in slightly murky water.

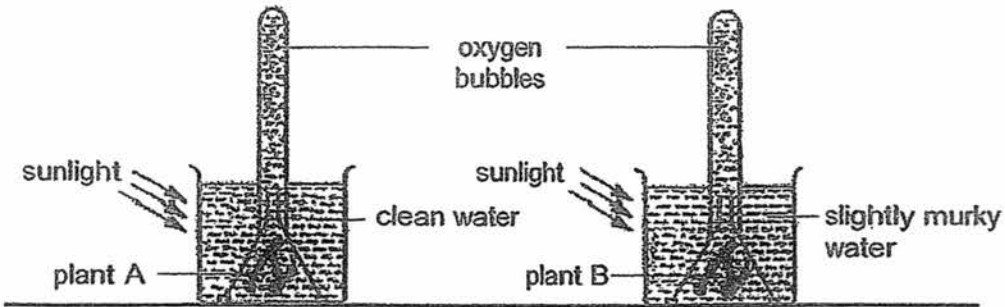

The number of oxygen bubbles given out by both plants over a period of 20 minutes was then counted.

- (a) Based on the given information, what was the aim of the experiment? [1]

---



---

- (b) The line graph below shows the results for plant A. Using a ruler and pencil, draw another straight line in the graph below to show the results for plant B and label the line as "plant B". [1]

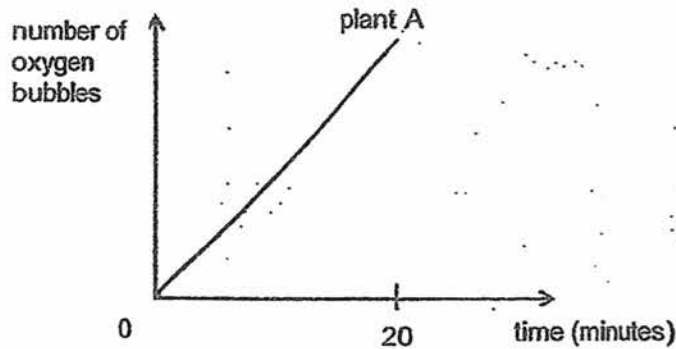

- (c) Based on the results of the experiment, explain why farmers would not want to rear fishes in slightly murky water even though there are plants in the water. [2]

---



---



---

(Go on to the next page)

SCORE	4
-------	---

37 Leaves have tiny openings called stomata on their surfaces.

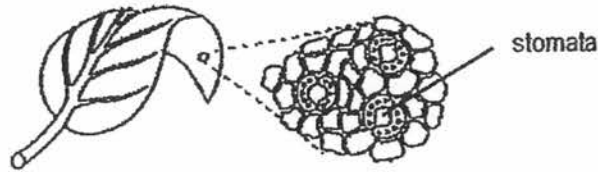

Ramada measured the changes in the size of the stomata of a plant in the garden at different time of the day. It was a clear sunny day when he did his observations. He plotted his results as shown below.

average size of stomata (unit)

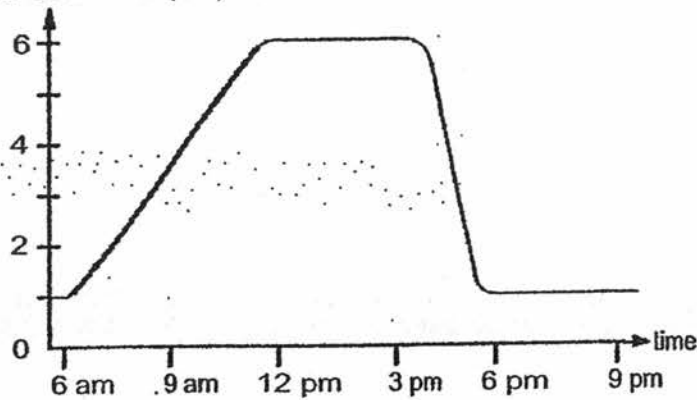

- (a) Based on the results in the graph, how do we know that the stomata were not completely closed at anytime? [1]

---



---

- (b) Why was the size of stomata the smallest between 6 pm to 9 pm? [1]

---



---

- (c) What is the disadvantage to the plant when it opens its stomata to the widest when the surrounding temperature is the hottest? [1]

---



---

(Go on to the next page)

SCORE	
	3

- 38 The diagram below shows a two-way switch installed at the staircase. The bulb can be switched on or off from either ends of the staircase.

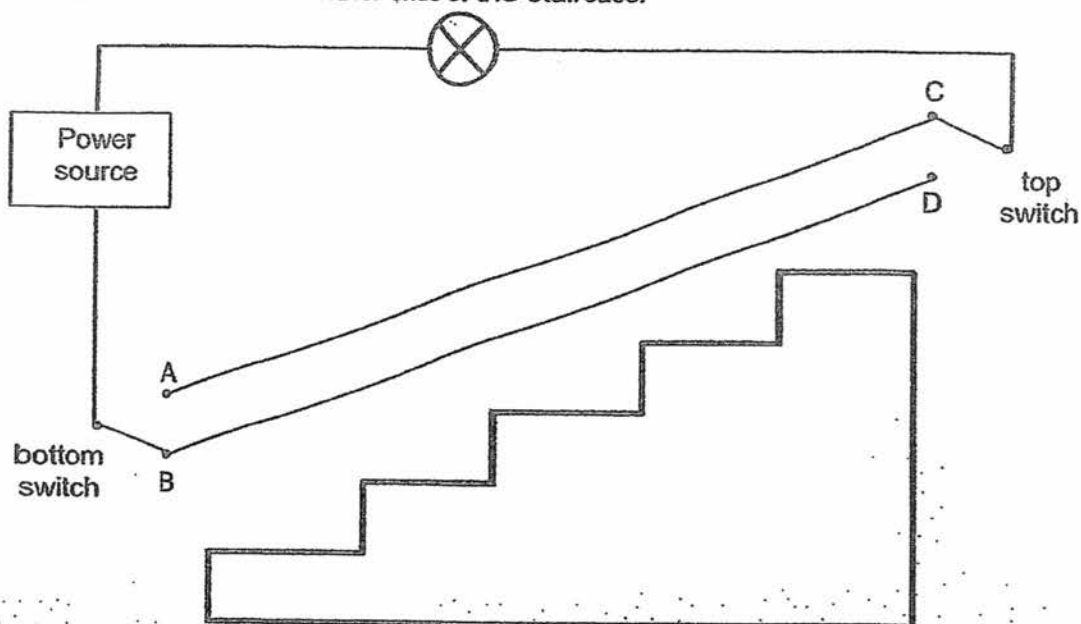

At the moment, the bulb is switched off. The bottom switch is connected to point B, while the top switch is connected to point C.

- (a) David is at the bottom of the staircase. What can he do to switch on the bulb at the bottom of the staircase? [1]

---



---

- (b) David walked up the staircase after he had switched on the bulb at the bottom of the staircase. What can David do to switch off the bulb at the top of the staircase? [1]

---



---

(Question 38 continues on page 12)

(Go on to the next page)

SCORE	
	2

- (c) David wanted to install three bulbs for the stairway while maintaining the same brightness as before for each bulb. In the diagram below, draw the wires between points E and F to show the connections between the three bulbs. [1]

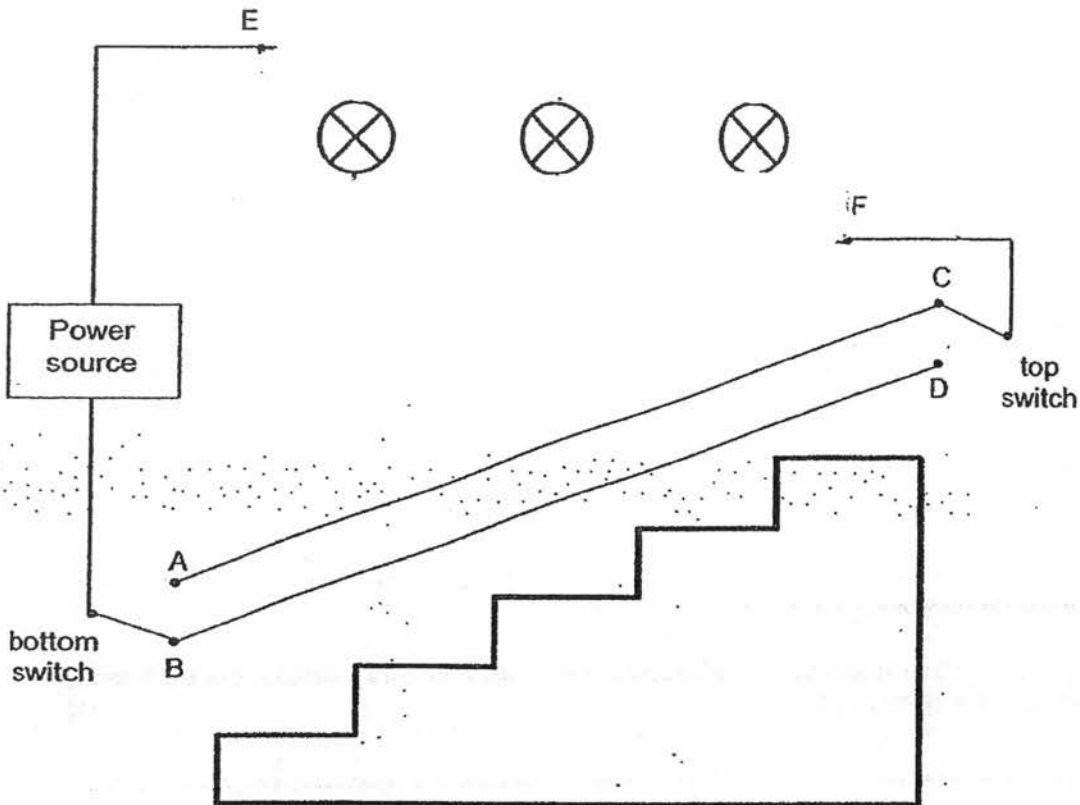

- (d) Other than having the same brightness as before, what is the advantage of having the bulbs connected in the way you have drawn in (c)? [1]

---



---

(Go on to the next page)

SCORE	
	2

39 Winston set up the experiment as shown below.

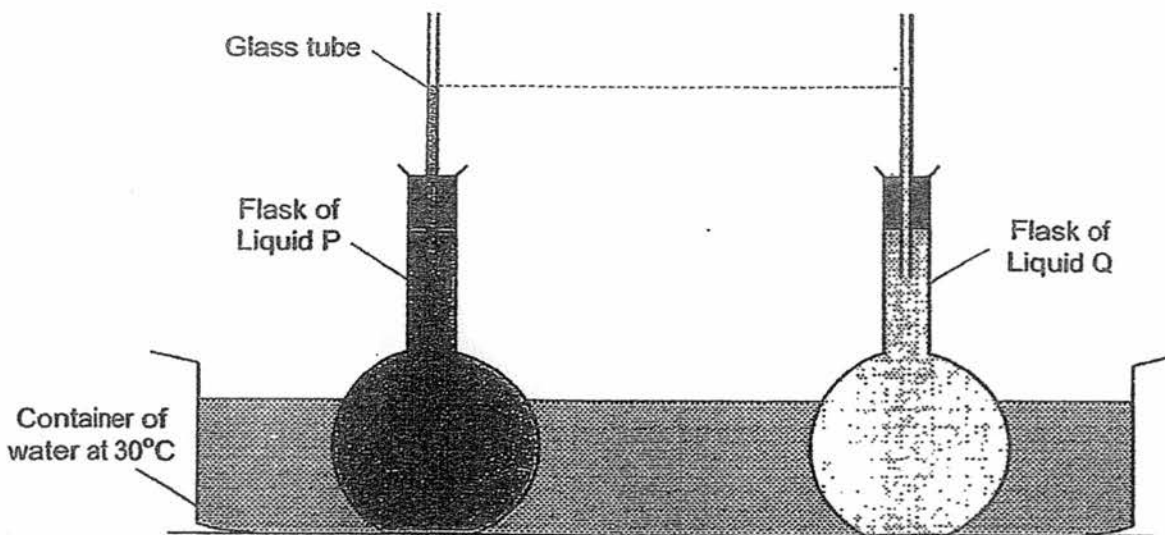

Winston ensured that when both flasks were immersed in the container of water at 30°C, the level of liquids P and Q in the glass tube were the same.

- (a) If liquid P is a better conductor of heat than liquid Q, state and compare what will happen to the level of liquids in both flasks when Winston adds ice cubes into the container of water. [1]

---



---

- (b) Explain your answer in (a).

---



---



---



---

(Question 39 continues on page 14)

(Go on to the next page)

SCORE	3
-------	---

Winston discovered that houses in cold countries usually have windows that have two layers of glass, trapping air in between them, as shown in the diagram below.

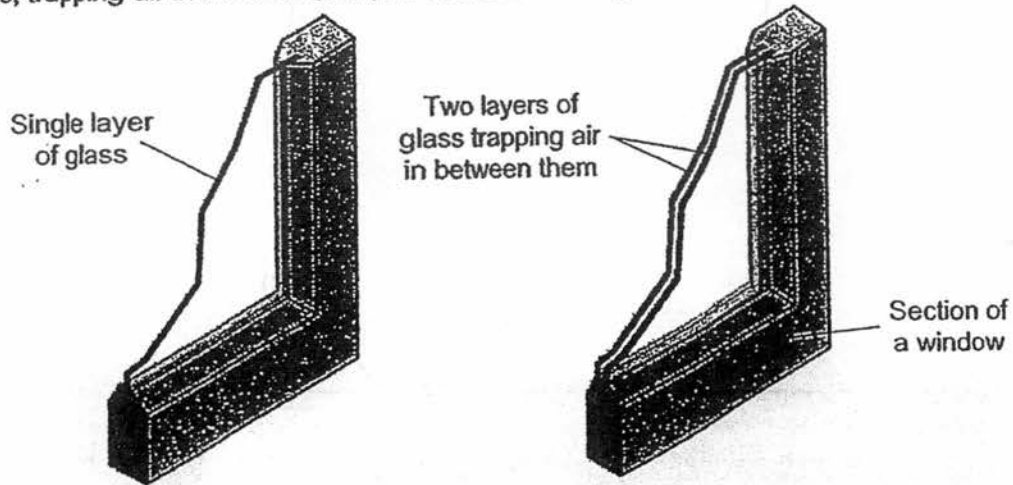

- (c) Explain how this helps to keep temperature inside the room higher than outside for a longer period of time, as compared to windows with only a single layer of glass. [2]

---

---

---

---

(Go on to the next page)

SCORE	
	2

40 The diagram below shows Caleb's toy scooter.

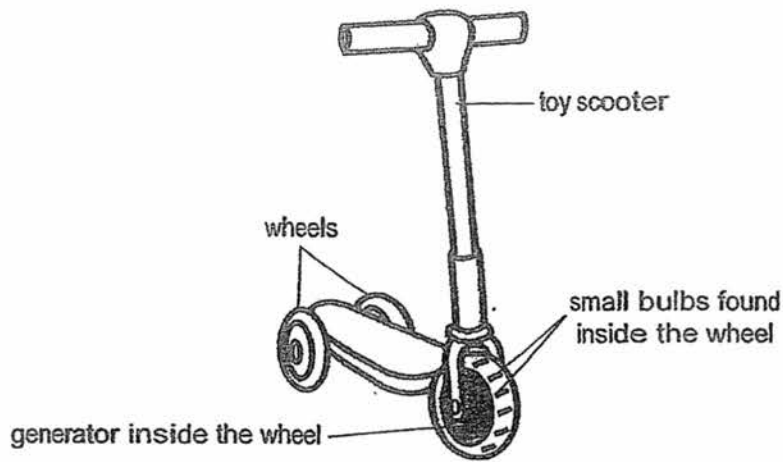

When Caleb steps on the scooter and pushes himself forward, the scooter will move and the small bulbs inside the wheels of the scooter will light up.

(a) What property should the material used to make the wheels have so that Caleb can see the lights when the wheel is turning? [1]

---



---

(b) Fill in the boxes below to show the energy conversion in the wheel when it started moving. [1]

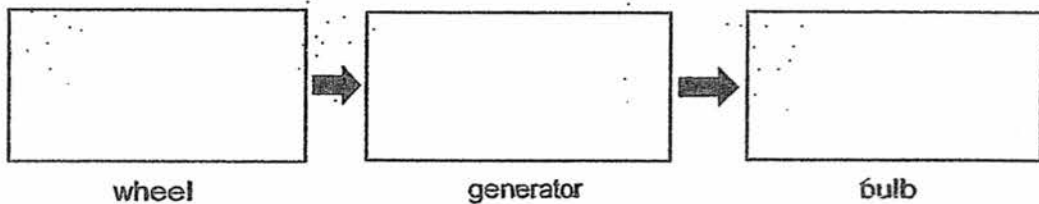

(c) Caleb noticed that the bulbs in the wheel do not always light up. Explain why. [1]

---



---

SCORE	3
-------	---

End of Paper





YEAR : 2017  
LEVEL : PRIMARY 6  
SCHOOL : : ANGLO-CHINESE (JUNIOR/PRIMARY)  
SUBJECT : : SCIENCE  
TERM : PRELIMINARY EXAMINATION

**Booklet A**

Q1	Q2	Q3	Q4	Q5	Q6	Q7
4	2	3	2	4	4	1
Q8	Q9	Q10	Q11	Q12	Q13	Q14
2	4	1	2	2	3	2
Q15	Q16	Q17	Q18	Q19	Q20	Q21
4	2	3	3	2	4	1
Q22	Q23	Q24	Q25	Q26	Q27	Q28
1	2	3	1	3	4	3

**Booklet B**

- Q29 (a) Object X is a magnet.
- (b) When the switch was closed, electricity flowed through the circuit causing the iron rod to be magnetised. The poles of the electromagnet and Object X facing each other were the same, and therefore Object X was repelled.
- (c) Add more batteries or add more coils.
- Q30 (a) Similarity: Both life cycles have an egg stage.  
Difference: Organism P has a 4-stage life cycle while Q has a 3-stage life cycle.
- (b) Pour away stagnant water in vases / flower pots so that P have no suitable place to lay their eggs.

- Q31 (a) **Glass X:**  
The outer surface of the glass.
- Glass Y:**  
Inner surface of the metal lid.
- (b) **The water vapour in the air in glass Y gained heat from the milk and came into contact with the cooler glass and cover where it lost heat and condensed into water droplets.**
- (c) **Plastic is a poorer conductor of heat than metal. So less water vapour will condense into tiny water drops.**
- Q32 (a) **The camouflage against the brown twigs. So removing the shell will decrease the chances of predators spotting the chicks and eating them.**
- (b) **So that it can find food.**
- Q33 (a) **When the trees are cut down, there will be less roots to hold the topsoil in place. When it rains heavily, the soil will be washed into the rivers and block out most of the light for fully submerged plants to photosynthesise and make food. Without food these plants will die.**
- (b) **There will be fewer trees to take in carbon dioxide during photosynthesis, so there will be more carbon dioxide in the atmosphere to trap more heat.**
- Q34 (a) **Gravitational force, frictional force.**
- (b) **Add a lubricant on the board. This reduces friction between the surface of the board & the surface of the striker, allowing it to move further.**

- Q35 (a) The metal cup. Metal is a better conductor of heat and it loses heat to the surroundings faster than styrofoam.
- (b) Ice-cube A. There is more water in the cup as the metal cup gained heat faster from the surroundings to the ice cube which caused the ice cube to melt faster.

- Q36 (a) To find out if the type / cleanliness of water affects the rate of photosynthesis in a water plant.

(b)

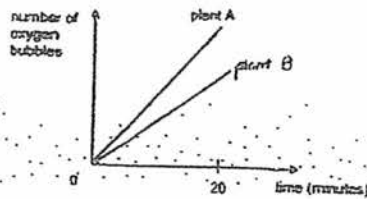

- (c) The water plants will not be able to receive sufficient sunlight for photosynthesis and will not produce enough oxygen for the fishes to breathe.

- Q37 (a) The average size of stomata is never at 0 units. / The smallest average size of stomata is 1 unit.

- (b) There is no light / less light / least light for photosynthesis.

- (c) It will allow more / too much water vapour to escape. The plant will lose more / too much water.

- Q38 (a) David can connect the bottom switch to point A.  
 (b) David could connect the top switch to point D.

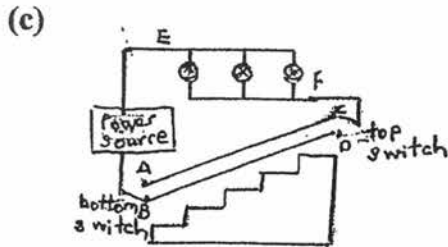

- (d) If one bulb fuses, the others will still light up.

- Q39 (a) The level of liquids in P and Q will decrease but the level of liquid in P will be lower than Q.  
 (b) When ice is added, liquid P will lose heat faster than liquid Q and contracts more than liquid Q.  
 (c) Air is a poor conductor of heat and will reduce the amount of heat lost from the room to the colder environment / air outside.

- Q40 (a) It is transparent and allows light to pass through.

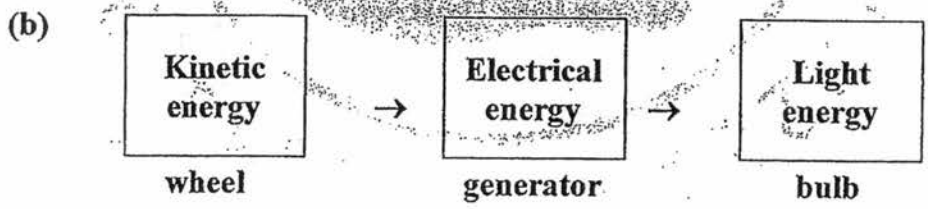

- (c) The wheel is not turning fast enough, so the generator does not have enough kinetic energy to be converted to electrical energy.

4

End