



**Maha Bodhi School**  
**2019 Semestral Assessment 1**  
**Primary 6**  
**Mathematics**  
**Paper 1**  
**(Booklet A)**

Name : \_\_\_\_\_ (      )

Class : Primary 6 \_\_\_\_\_

Date : 15 May 2019

Total duration for Booklets A and B: 1 hour

---

**INSTRUCTIONS TO CANDIDATES:**

1. Do not turn over this page until you are told to do so.
2. Follow all instructions carefully.
3. Answer all questions.
4. Shade your answers in the Optical Answer Sheet (OAS) provided.
5. The use of calculators is **NOT** allowed.

This booklet consists of 6 printed pages.

Questions 1 to 10 carry 1 mark each. Questions 11 to 15 carry 2 marks each.  
For each question, four options are given. One of them is the correct answer.  
Make your choice (1, 2, 3 or 4) and shade your answer on the Optical Answer Sheet.  
(20 marks)

---

1. Round 819 962 to the nearest thousand.

- (1) 800 000
- (2) 810 000
- (3) 819 000
- (4) 820 000

2. Which one of the following fractions is smaller than  $\frac{1}{2}$ ?

- (1)  $\frac{5}{8}$
- (2)  $\frac{2}{3}$
- (3)  $\frac{3}{4}$
- (4)  $\frac{4}{9}$

3. Express 308 cm in metres.

- (1) 0.308 m
- (2) 3.08 m
- (3) 3.8 m
- (4) 30.8 m

4. In the figure below, RSQ is a straight line. What is the area of triangle PRS?

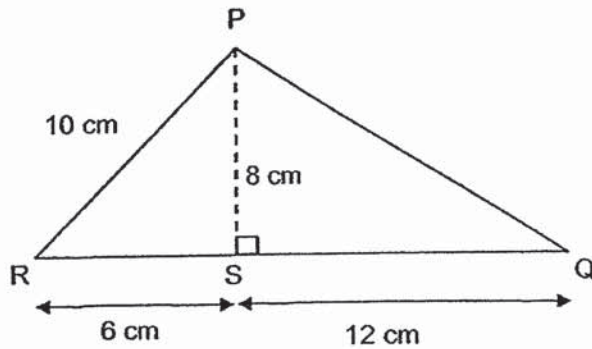

- (1)  $24 \text{ cm}^2$   
(2)  $30 \text{ cm}^2$   
(3)  $48 \text{ cm}^2$   
(4)  $72 \text{ cm}^2$
5. The figure shows some roads on a map.

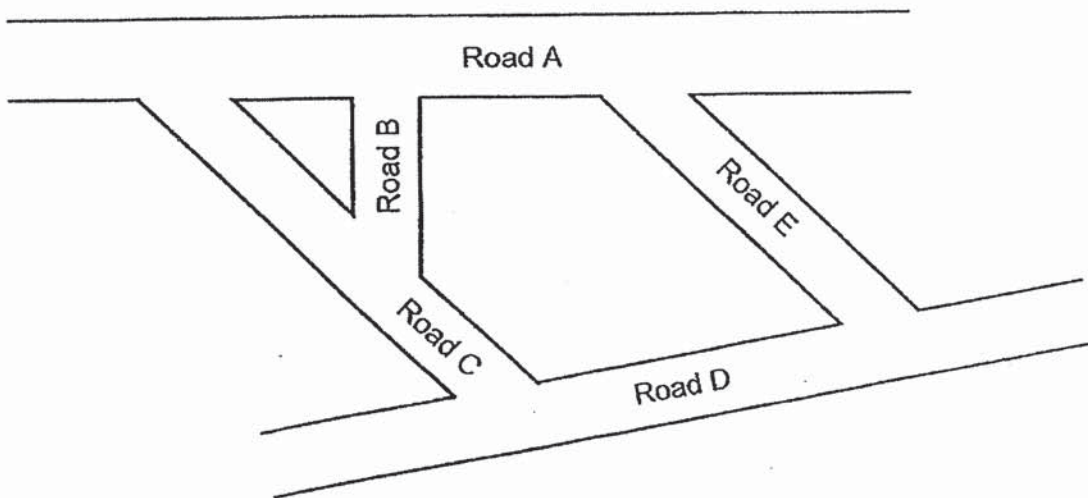

Which two roads are perpendicular to each other?

- (1) Road A and Road B  
(2) Road A and Road D  
(3) Road B and Road C  
(4) Road C and Road E

6. For every 5 chocolate muffins Joe baked, he also baked 7 strawberry muffins. He baked 210 chocolate muffins. How many strawberry muffins did he bake?

- (1) 30
- (2) 42
- (3) 212
- (4) 294

7. Express  $2\frac{1}{2}\%$  as a decimal.

- (1) 0.025
- (2) 0.25
- (3) 2.5
- (4) 25

8. Sally bought 3 durians that cost \$36, \$23 and \$19. What was the average price she paid for a durian?

- (1) \$23
- (2) \$26
- (3) \$39
- (4) \$78

9. Which of the following shows the correct base and its corresponding height of triangle XYZ?

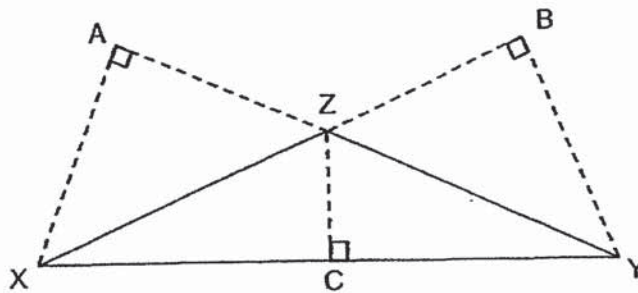

|     | Base | Corresponding height |
|-----|------|----------------------|
| (1) | YZ   | CZ                   |
| (2) | BX   | BY                   |
| (3) | CY   | CZ                   |
| (4) | YZ   | AX                   |

10. Gavin travelled a journey of 240 km. He drove at an average speed of 60 km/h for the first 1 hour. For the remaining journey, he drove at an average speed of 90 km/h. What was the total time taken for the journey?
- (1) 5 h  
 (2) 2 h  
 (3) 3 h  
 (4) 4 h
11. Alex started jogging at 7.05 am. After jogging a distance of 900 m, it was 7.15 am. What was his average speed in m/min?
- (1) 45 m/min  
 (2) 60 m/min  
 (3) 90 m/min  
 (4) 180 m/min

12. Zann cut a ribbon of length 1.44 m into 3 pieces. The first piece was 3 times as long as the second piece. The second piece was 2 times as long as the third piece. How long was the first piece?

- (1) 0.16 m
- (2) 0.48 m
- (3) 0.72 m
- (4) 0.96 m

13. John has some red and blue marbles. The ratio of the number of red marbles to the number of blue marbles is 5 : 2. He gives  $\frac{3}{4}$  of his red marbles away. What will be the new ratio of the number of red marbles to the total number of marbles he has in the end?

- (1) 5 : 8
- (2) 5 : 13
- (3) 15 : 8
- (4) 15 : 23

14. Bella worked as a cashier at a supermarket. She is paid according to the rates as shown below. She worked from 10 am to 9.30 pm. How much was she paid?

| Working Hours | Rate                          |
|---------------|-------------------------------|
| 10 am to 8 pm | \$8 per hour                  |
| 8 pm to 11 pm | \$12 per hour or part thereof |

- (1) \$92
- (2) \$98
- (3) \$104
- (4) \$138

15. The figure below is made up of 3 identical squares. The area of the shaded part is  $54 \text{ cm}^2$ . What is the length of one side of the square?

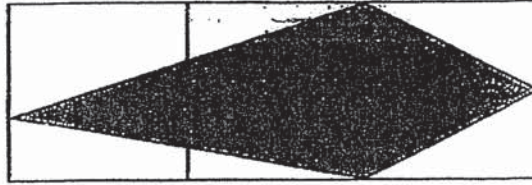

- (1) 6 cm
- (2) 9 cm
- (3) 18 cm
- (4) 36 cm

---- End of Booklet A ----



**Maha Bodhi School**  
**2019 Semestral Assessment 1**  
**Primary 6**  
**Mathematics**  
**Paper 1**  
**(Booklet B)**

Name : \_\_\_\_\_ (      )

Marks:

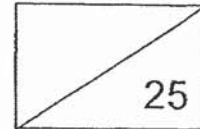

Class : Primary 6 \_\_\_\_\_

Date : 15 May 2019

Total Duration for Booklets A and B: 1 hour

---

**INSTRUCTIONS TO CANDIDATES:**

1. Do not turn over this page until you are told to do so.
2. Follow all instructions carefully.
3. Answer all questions.
4. Write all your answers in this booklet.
5. The use of calculators is **NOT** allowed.

This booklet consists of 6 printed pages.





Questions 16 to 20 carry 1 mark each. Write your answers in the spaces provided.  
For questions which require units, give your answers in the units stated. (5 marks)

---

16. How many common multiples of 2 and 7 are smaller than 30?

Ans: \_\_\_\_\_

17. Express  $6\frac{5}{8}$  as a decimal correct to 2 decimal places.

Ans: \_\_\_\_\_

18. In the scale below, what is the value of Y?

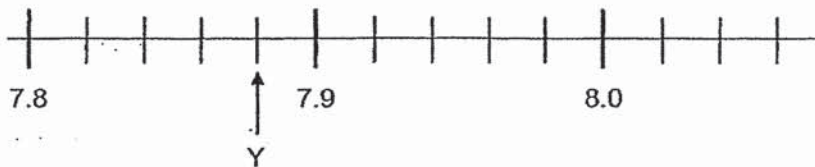

Ans: \_\_\_\_\_

19. The actual time Grace left her house to go to the library was 14 35. When she reached the library, she looked at her watch and the time shown was 15 10. Her watch was 10 minutes faster than the actual time. How long did Grace take to reach the library?

Ans: \_\_\_\_\_ min

20. A machine can produce 8 ribbons in 5 seconds. How many ribbons can the same machine produce in 1 minute?

Ans: \_\_\_\_\_ ribbons

Questions 21 to 30 carry 2 marks each. Show your working clearly in the space below each question and write your answers in the spaces provided. For questions which require units, give your answers in the units stated. (20 marks)

21. The figure shows a garden in the shape of a semicircle with a diameter of 10 m. Mr Lee wants to put a fence around the garden. What is the length of the fence he needs? Leave your answer in terms of  $\pi$ .

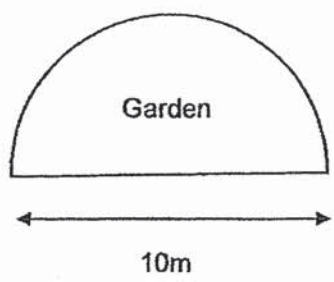

Ans: \_\_\_\_\_ m

22. The figure below shows a parallelogram ABCE. BCD is a straight line. Find  $\angle BAE$ .

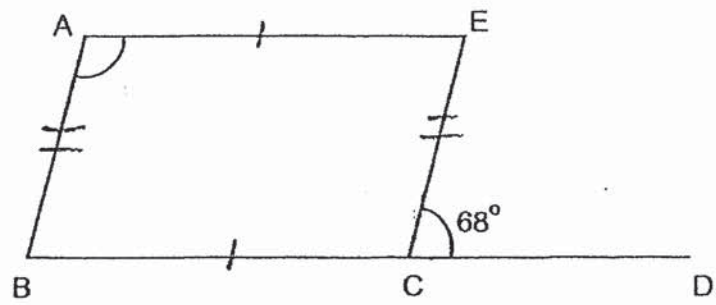

Ans: \_\_\_\_\_  $^\circ$

23. Dan and Eileen received an average of \$138 each from their father. Dan received twice as much as Eileen. How much did Eileen receive?

Ans: \$ \_\_\_\_\_

24. The table below shows the masses of a bag of rice and a packet of noodles.

| Item              | Mass (g) |
|-------------------|----------|
| Bag of Rice       | $4m$     |
| Packet of Noodles | $(m-3)$  |

Express the total mass of 1 bag of rice and 1 packet of noodles in terms of  $m$ .

Ans: \_\_\_\_\_ g

25. A semicircle is drawn inside a rectangle ABCE as shown below. The perimeter of rectangle ABCE is 42 cm. Find the area of the quadrant FDC. Take  $\pi = \frac{22}{7}$ .

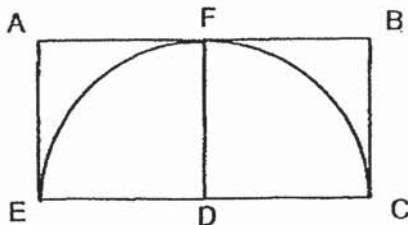

Ans: \_\_\_\_\_ cm<sup>2</sup>

26. Mrs Wang bought a dress at \$90 after she was given a 25% discount. Mrs Ramesh bought the same dress at \$78 during another sale. What was the percentage discount given to Mrs Ramesh if the original price remained the same?

Ans: \_\_\_\_\_%

27. Jim travelled from Town A to Town B in 5 hours. He travelled at an average speed of 70 km/h for the first 210 km. He then increased his speed by 10 km/h for the rest of the journey. What was the distance between Town A and Town B?

Ans: \_\_\_\_\_ km

28.  $\frac{3}{5}$  of Gabriel's savings is equal to  $\frac{1}{3}$  of Bryan's savings. Bryan saves \$60 more than Gabriel. What is the total savings of both boys?

Ans: \$ \_\_\_\_\_

|     |
|-----|
| / 6 |
|-----|

29. The diagram below shows an open-top box. When it is fully packed with 1-cm cubes, how many cubes touch the inside of the box?

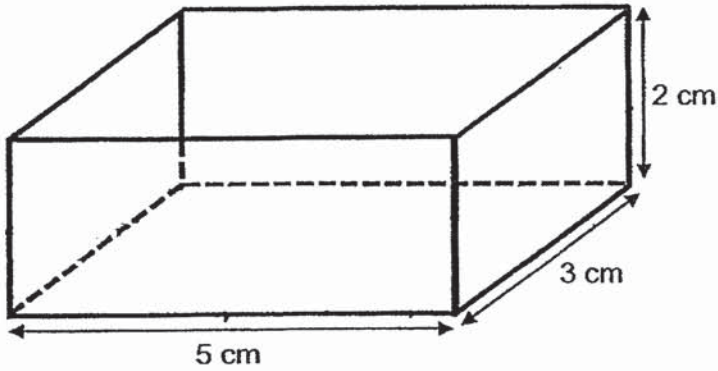

Ans: \_\_\_\_\_ cubes

30. There are 15 boys in 6 Kindness. They scored an average of 72 marks in a Math test. The girls in the class scored an average of 79 marks. The average marks scored by the children in the class is 76. How many children are there in 6 Kindness?

Ans: \_\_\_\_\_



----- End of Booklet B -----

**Remember to check your work!**

|     |
|-----|
| / 4 |
|-----|



**Maha Bodhi School**  
**2019 Semestral Assessment 1**  
**Primary 6**  
**Mathematics**  
**Paper 2**

Name : \_\_\_\_\_ (    )

Class : Primary 6 \_\_\_\_\_

Date : 15 May 2019

Duration: 1 h 30 min

---

**INSTRUCTIONS TO CANDIDATES:**

1. Do not turn over this page until you are told to do so.
2. Follow all instructions carefully.
3. Answer all questions.
4. Write your answers in this booklet.
5. The use of an approved calculator is expected, where appropriate.

| Paper        | Booklet | Marks Obtained | Max Marks  |
|--------------|---------|----------------|------------|
| 1            | A       |                | 20         |
|              | B       |                | 25         |
| 2            |         |                | 55         |
| <b>Total</b> |         |                | <b>100</b> |

Parent's signature: \_\_\_\_\_

This booklet consists of 13 printed pages.





Questions 1 to 5 carry 2 marks each. Show your working clearly in the space provided for each question and write your answers in the spaces provided. For questions which require units, give your answers in the units stated. (10 marks)

1. In the figure below, ABC is a right-angled triangle.  $\angle BAC = 40^\circ$  and  $CE = CD$ . ACD and BCE are straight lines. Find  $\angle CED$ .

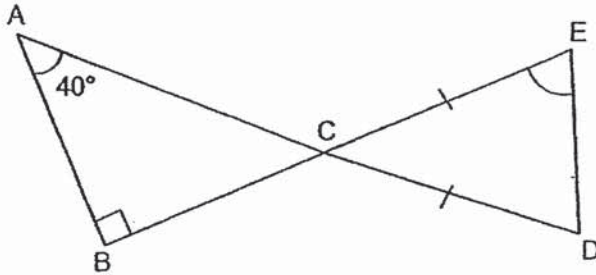

Ans: \_\_\_\_\_°

2. Ryan placed some wooden blocks in a pattern. Part of the pattern is shown below. There were 3 white blocks between every 2 black blocks. He used a total of 19 black blocks. How many white blocks did he use?



Ans: \_\_\_\_\_

3. What is the least number of additional squares that must be shaded so that the dotted line AB is a line of symmetry of the figure?

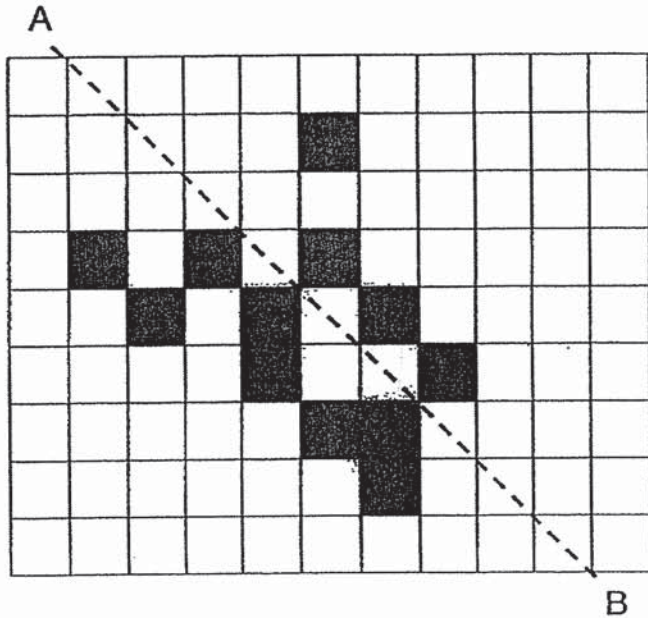

Ans: \_\_\_\_\_

4. The ratio of Anne's savings to Betty's savings was 5 : 3 at first. After Anne had spent \$112 and Betty had saved another \$80, they had an equal amount of savings each. How much savings did Anne have at first?

Ans: \$ \_\_\_\_\_

5. Lia had 40 sweets. She kept  $k$  sweets for herself and divided the rest equally among 6 friends. How many sweets did each friend receive when  $k = 4$ ?

Ans: \_\_\_\_\_

For questions 6 to 17, show your working clearly in the space provided for each question and write your answers in the spaces provided. The number of marks available is shown in brackets [ ] at the end of each question or part-question. (45 marks)

---

6. Mrs Lim bought some glasses at \$8 each and some cups at \$4 each. For every 17 glasses she bought, she also bought 3 cups. She paid a total of \$9324. What is the total number of glasses Mrs Lim bought?

Ans: \_\_\_\_\_ [3]

7. The figure below is made up of 4 identical squares. Find the area of the shaded part of the figure. Take  $\pi = 3.14$ .

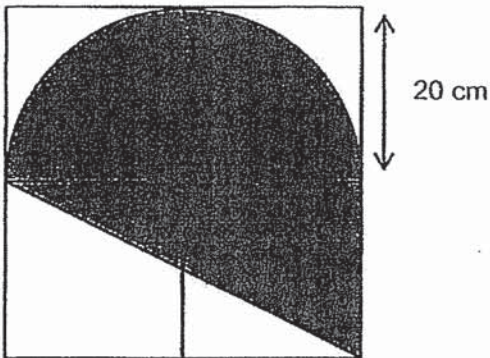

Ans: \_\_\_\_\_ [3]

8. Jason and Michael had 128 marbles altogether. Jason gave away  $\frac{1}{4}$  of his marbles while Michael gave away 37 of his marbles. They had the same number of marbles in the end. How many marbles did Michael have at first?

Ans: \_\_\_\_\_ [4]

4

|  |     |
|--|-----|
|  | / 4 |
|--|-----|

9.  $\frac{1}{4}$  of a container was filled with water at first. 18 000 ml of water was added to the container and it became  $\frac{5}{8}$  filled. All the water in the container was then poured into an empty Tank A as shown below.

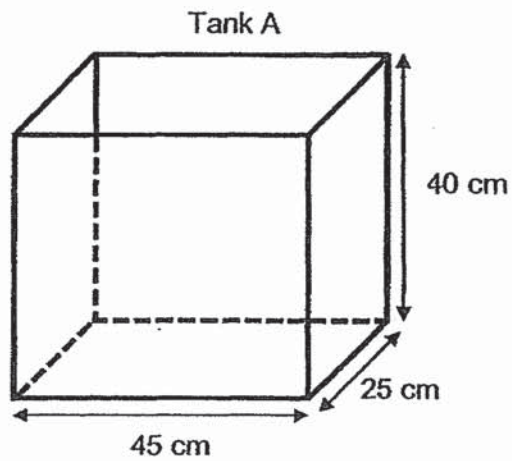

- (a) How much water was poured into Tank A?  
(b) What fraction of Tank A was filled with water? Give your answer in the simplest form.

Ans: (a) \_\_\_\_\_ [2]

(b) \_\_\_\_\_ [2]

10. The line graph shows the amount of water used by a family from March to June. The water used is charged at the rate of 85¢ per  $m^3$ .

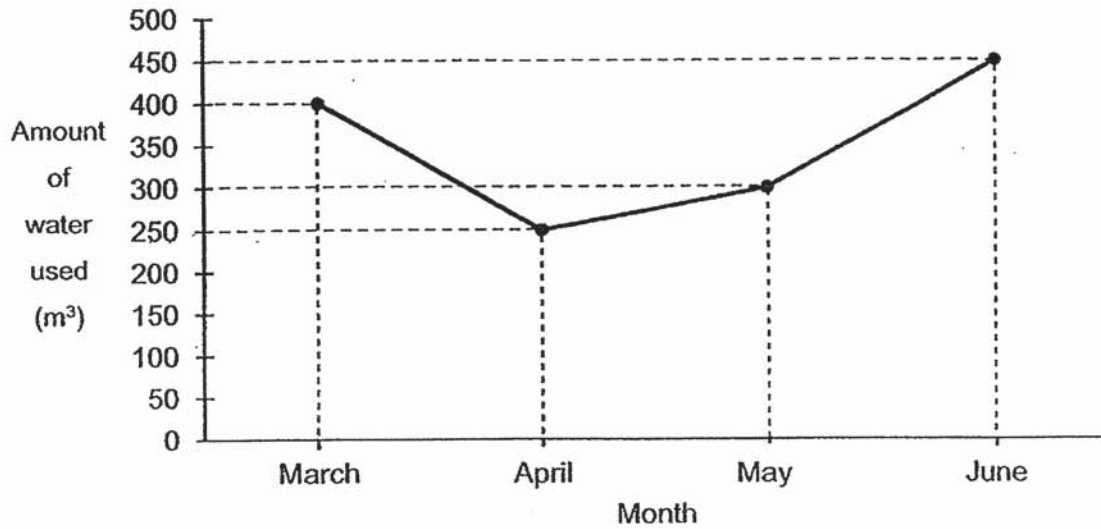

- (a) What was the average amount paid per month for the water used from March to June?
- (b) The average amount of water used from May to July is  $400 m^3$ . Find the amount of water used in July.

Ans: (a) \_\_\_\_\_ [2]

(b) \_\_\_\_\_ [2]

11. Joshua bought 30 notepads and 70 pens at \$130. He still had some money left. He would be short of \$0.80 if he were to buy another notepad. However, he would have \$0.70 left if he were to buy another pen. How much did each notepad cost?

Ans: \_\_\_\_\_ [3]

7

|  |     |
|--|-----|
|  | / 3 |
|--|-----|



12. In the figure, PQRS is a rhombus and PQT is an isosceles triangle.  $QP = QT$ ,  $\angle PSR = 66^\circ$  and  $\angle TPR = 27^\circ$ . Find  $\angle PQT$ .

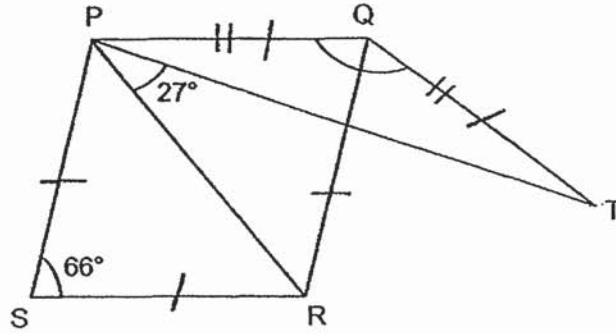

Ans: \_\_\_\_\_ [3]

13. A van travels from Town P to Town Q in 8 h. A truck travels the same route in 11 h. The van travels at a speed which is 15 km/h faster than the truck. What is the speed of the van?

Ans: \_\_\_\_\_ [3]

14. Eric had 192 more stickers than Leon at first. After Eric gave away 250 stickers and Leon bought another 168 stickers, Leon had 3 times as many stickers as Eric. What is the total number of stickers the two boys had at first?

Ans: \_\_\_\_\_ [4]

15. Aaron, Bala and Caleb had some savings. Aaron saved 50% as much as the total amount saved by Bala and Caleb. Bala saved 75% as much as the total amount saved by Aaron and Caleb. Aaron saved \$7048 more than Caleb. How much did the 3 boys save altogether?

Ans: \_\_\_\_\_ [4]

16. Spencer used the arc as shown in Figure A to design a swimming pool. The shaded part in Figure B shows the swimming pool that Spencer had designed.

(a) Find the perimeter of the swimming pool.

(b) Find area of the swimming pool.

Take  $\pi = 3.14$

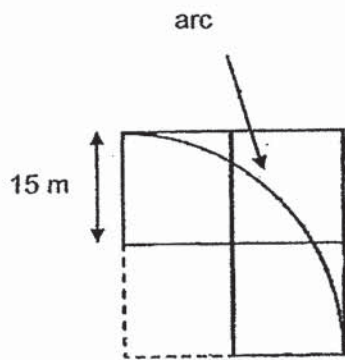

Figure A

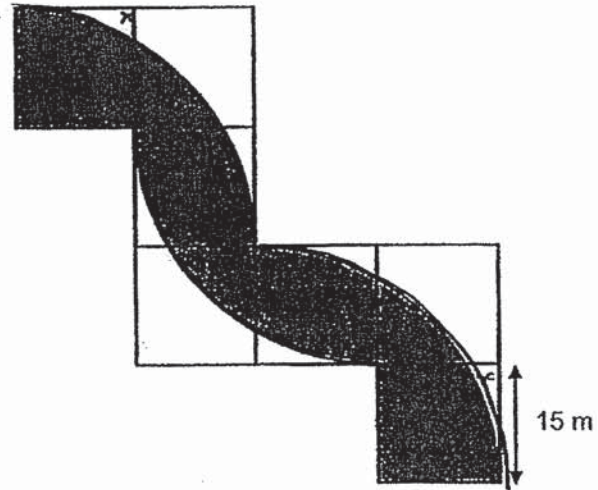

Figure B

Ans: (a) \_\_\_\_\_ [2]

(b) \_\_\_\_\_ [3]

17. John only has cookies and Ben only has tarts at first. John gave half of his cookies to Ben. Ben gave half of his tarts to John. John then ate 14 tarts and Ben ate 16 cookies. After that, the ratio of the number of tarts to the number of cookies John had was 1 : 7 and the ratio of the number of tarts to the number of cookies Ben had was 1 : 4.

- (a) How many tarts did Ben have at first?  
(b) What is the ratio of the total number of tarts to the total number of cookies they had at first? Give your answer in the simplest form.

Ans: (a) \_\_\_\_\_ [3]

(b) \_\_\_\_\_ [2]

/ 5



----- The End -----

***Remember to check your work!***







|      |  |
|------|--|
|      | $\frac{42}{120} \times 100 = 35\%$   |
| Q27) | $210\text{km} \div 70\text{km/h} = 3\text{h}$<br>$5\text{h} - 3\text{h} = 2\text{h}$<br>$70\text{km/h} + 10\text{km/h} = 80\text{km/h}$<br>$80\text{km/h} \times 2\text{h} = 160\text{km}$<br>$160\text{km} + 210\text{km} = 370\text{km}$ |
| Q28) | $\frac{1}{3} = \frac{3}{9}$<br>$9 - 5 = 4$<br>4 units = 60<br>$9 + 5 = 14$<br>14 units = $\frac{60}{4} \times 14 = \$210$  |
| Q29) | 27   |
| Q30) | $76 - 72 = 4$<br>$15 \times 4 = 60$<br>$79 - 76 = 3$<br>$60 \div 3 = 20$<br>$20 + 15 = 35$   |

## PAPER 2

|     |   |
|-----|---|
| Q1) | $\angle ACB = 180^\circ - 90^\circ - 40^\circ = 50^\circ$<br>$\angle ACB = \angle ECD = 50^\circ$<br>$\angle CED = \angle CDE$<br>$\frac{180^\circ - 50^\circ}{2} = 65^\circ$ |
| Q2) | $19 - 1 = 18$<br>$18 \times 3 = 54$   |
| Q3) | 6   |
| Q4) | $5 - 3 = 2$<br>2 units = $112 + 80 = 192$<br>5 units = $\frac{192}{2} \times 5 = \$480$   |
| Q5) | $\frac{40-4}{6} = 6$  |
| Q6) | $8 \times 17 = 136$<br>$4 \times 3 = 12$<br>$136 + 12 = 148$<br>$9324 \div 148 = 63$<br>$63 \times 17 = 1071$   |
| Q7) | $20 \times 2 = 40$<br>$\frac{1}{2} \times 40 \times 20 = 400$<br>$3.14 \times 20 \times 20 \times \frac{1}{2} = 628$  |

|      |   |
|------|---|
|      | $400 + 628 = 1028\text{cm}^2$   |
| Q8)  | $128 - 37 = 91$<br><b>7 units = 91</b><br><b>1 unit = <math>91 \div 7 = 13</math></b><br><b>3 units = <math>13 \times 3 = 39</math></b><br><b><math>39 + 37 = 76</math></b>   |
| Q9)  | <b>a)</b> $\frac{1}{4} = \frac{2}{8}$<br>$\frac{5}{8} - \frac{2}{8} = \frac{3}{8}$<br>$\frac{18000}{3} \times 5 = 30000\text{ml}$<br><b>b)</b> $45 \times 25 \times 40 = 45000$<br>$\frac{30000}{45000} = \frac{2}{3}$  |
| Q10) | <b>a)</b> $400 \times 0.85 = 340$<br>$250 \times 0.85 = 212.50$<br>$300 \times 0.85 = 255$<br>$450 \times 0.85 = 382.50$<br>$382.50 + 255 + 212.50 + 340 = 1190$<br>$1190 \div 4 = \$297.50$<br><b>b)</b> $400 \times 3 = 1200$<br>$1200 - 300 - 450 = 450\text{m}^3$   |
| Q11) | The cost of 31 notepads + 70 pens = Total amount of money + \$0.80<br>The cost of 30 notepads + 71 pens = Total amount of money - \$0.70<br>The cost of 1 notepad – 1 pen = \$0.80 + \$0.70 = \$1.50<br><b><math>\\$1.50 \times 70 = \\$105</math></b><br><b><math>\\$130 + \\$105 = \\$235</math></b><br><b><math>\\$235 \div 100 = \\$2.35</math></b> |
| Q12) | $\angle SPR = \angle SRP = \frac{180^\circ - 66^\circ}{2} = 57^\circ$<br>$\angle SRP = \angle QPR = 57^\circ$<br>$\angle QPT = 57^\circ - 27^\circ = 30^\circ$<br>$\angle QPT = \angle QTP = 30^\circ$<br>$\angle PQT = 180^\circ - 30^\circ \times 2 = 120^\circ$  |
| Q13) | $15\text{km/h} \times 8\text{h} = 120\text{km}$<br>$11\text{h} - 8\text{h} = 3\text{h}$<br>$120\text{km} \div 3\text{h} = 40\text{km/h}$<br>$40\text{km/h} + 15\text{km/h} = 55\text{km/h}$   |
| Q14) | <b>2 units = 226</b><br><b>1 unit = <math>226 \div 2 = 113</math></b><br><b><math>113 + 58 = 171</math></b><br><b><math>113 + 250 = 363</math></b><br><b><math>171 + 363 = 534</math></b>   |

|  |  |  |  |
|--|--|--|--|
| Q15)   | $2 \text{ units} = 7048$<br>$1 \text{ unit} = 7048 \div 2 = 3524$<br>$21 \text{ units} = 3524 \times 21$<br>$= \$74004$  |  |  |
| Q16)   | a) 201.3m<br>b) $3.14 \times 30 \times 30 \times \frac{1}{4} = 706.5$<br>$15 \times 15 \times 4 = 900$<br>$900 - 706.5 = 193.5$<br>$15 \times 15 \times 7 - 193.5 \times 3 = 994.5m^2$   |  |  |
| Q17)   | <table style="width: 100%; border: none;"> <tr> <td style="width: 50%; border: none;"> <math>1 \text{ part} + 14 = 1 \text{ unit}</math><br/> <math>7 \text{ part} = 4 \text{ unit} + 16</math><br/> <math>7 \text{ part} + 98 = 7 \text{ unit}</math><br/> <math>3 \text{ unit} = 16 + 98 = 114</math><br/> <math>1 \text{ unit} = 114 \div 3 = 38</math> </td> <td style="width: 50%; border: none;"> <math>1 \text{ part} = 38 - 14 = 24</math><br/> <math>24 + 38 + 14 = 76</math><br/> <math>7 \text{ parts} = 24 \times 7 = 168</math><br/> <math>4 \text{ units} = 38 \times 4 = 152</math><br/> <math>152 + 168 + 16 = 336</math> </td> </tr> </table><br>a) 76<br>b) $\frac{76}{336} = 19:84$ | $1 \text{ part} + 14 = 1 \text{ unit}$<br>$7 \text{ part} = 4 \text{ unit} + 16$<br>$7 \text{ part} + 98 = 7 \text{ unit}$<br>$3 \text{ unit} = 16 + 98 = 114$<br>$1 \text{ unit} = 114 \div 3 = 38$ | $1 \text{ part} = 38 - 14 = 24$<br>$24 + 38 + 14 = 76$<br>$7 \text{ parts} = 24 \times 7 = 168$<br>$4 \text{ units} = 38 \times 4 = 152$<br>$152 + 168 + 16 = 336$ |
| $1 \text{ part} + 14 = 1 \text{ unit}$<br>$7 \text{ part} = 4 \text{ unit} + 16$<br>$7 \text{ part} + 98 = 7 \text{ unit}$<br>$3 \text{ unit} = 16 + 98 = 114$<br>$1 \text{ unit} = 114 \div 3 = 38$ | $1 \text{ part} = 38 - 14 = 24$<br>$24 + 38 + 14 = 76$<br>$7 \text{ parts} = 24 \times 7 = 168$<br>$4 \text{ units} = 38 \times 4 = 152$<br>$152 + 168 + 16 = 336$   |  |  |