

METHODIST GIRLS' SCHOOL
Founded In 1887



PRELIMINARY EXAMINATION 2024
PRIMARY 6
SCIENCE

BOOKLET A

Total Time for Booklets A and B: 1 hour 45 minutes

INSTRUCTIONS TO CANDIDATES

Do not turn over this page until you are told to do so.

Follow all instructions carefully.

Answer all questions.

Shade your answers in the Optical Answer Sheet (OAS) provided.

Name: _____ ()

Class: Primary 6: _____

Date: 21 August 2024

This booklet consists of 19 printed pages including this page.

For each question from 1 to 28, four options are given. One of them is the correct answer. Make your choice (1, 2, 3 or 4). Shade the correct oval on the Optical Answer Sheet (OAS). [56 marks]

1 Jael saw animal X in a muddy area.



Animal X

Animal X has the following characteristics:

- A It has fins.
- B It breathes through gills.
- C It has scales as outer body covering.

Based on the characteristics, which animal group does animal X belong to?

- (1) fish
- (2) insect
- (3) reptile
- (4) amphibian

2 The flow chart below shows information of four different organisms, J, K, L and M.

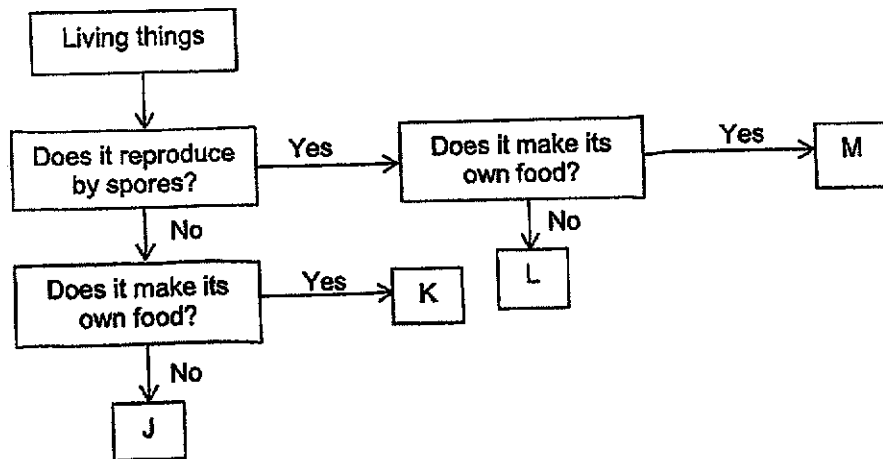

Which of the following correctly identifies organisms J, K, L and M?

| | J | K | L | M |
|-----|-----------|----------|-----------|-----------|
| (1) | mushroom | rose | moss | earthworm |
| (2) | earthworm | moss | mushroom | rose |
| (3) | rose | mushroom | earthworm | moss |
| (4) | earthworm | rose | mushroom | moss |

(Go on to the next page)

3

- 3 Study the diagrams of two cells, G and H, below.

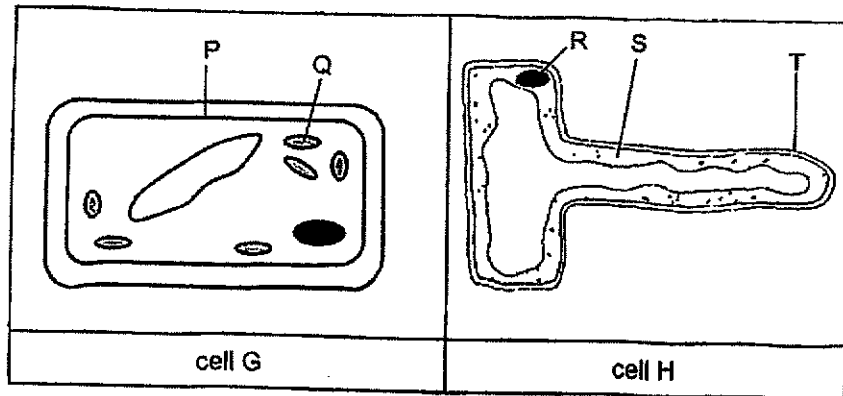

Which cell parts show that cells G and H are plant cells?

- (1) Q and T
 - (2) P and R
 - (3) P, R and S
 - (4) P, Q and T
- 4 Marcus ate an equal amount of food A and B. The amount of food A and B that remained undigested in each organ of his digestive system were measured.

The graph below shows the change in the percentage of undigested food.

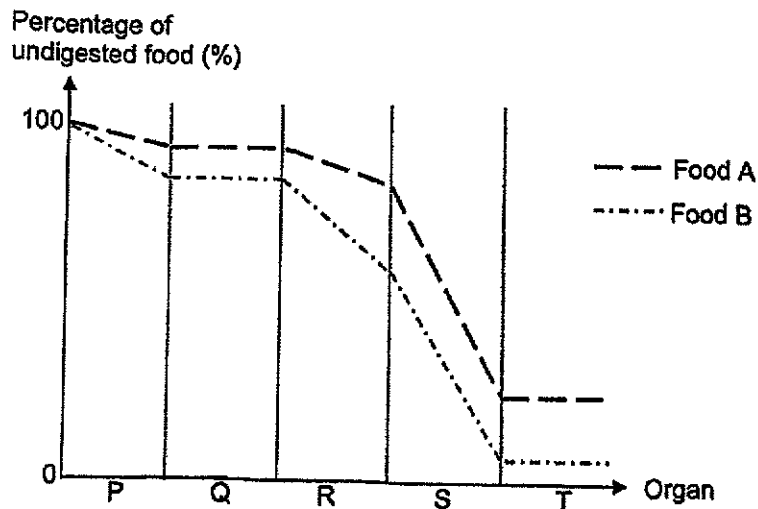

Based on the above graph, which of the following statements is correct?

- (1) Digestion of food A and B ends in organ T.
- (2) Food A and B are not digested in organ P.
- (3) Organ R digested more food A than organ S.
- (4) Food B is not digested in organ Q of the digestive system.

(Go on to the next page)

5 The diagram below shows a germinating seed.

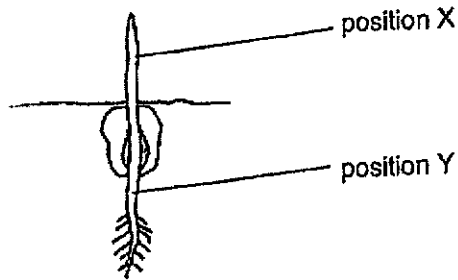

Which one of the following shows the directions in which food and water are being transported to at positions X and Y?

| | Direction of food at | | Direction of water at | |
|-----|----------------------|------------|-----------------------|------------|
| | Position X | Position Y | Position X | Position Y |
| (1) | ↑ | ↑ | ↓ | ↓ |
| (2) | ↑ | ↓ | ↑ | ↑ |
| (3) | ↓ | ↑ | ↓ | ↑ |
| (4) | ↓ | ↓ | ↑ | ↑ |

6 Clyde wanted to find out which parts of a flower must be present for the flower to develop into a fruit. With the four flowers still growing on the plant, he removed some parts of each flower as shown below.

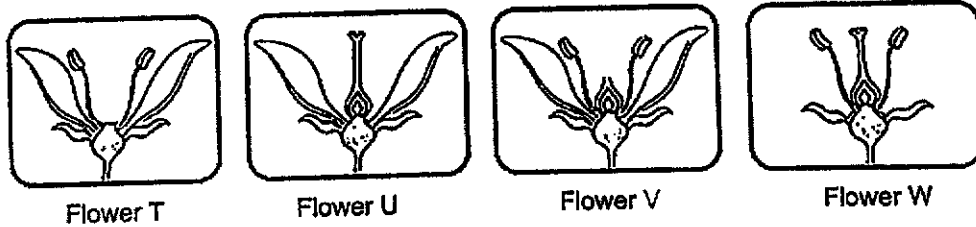

Clyde dusted pollen grains over all the four flowers.

Which of the above flower(s) would not develop into fruit(s)?

- (1) Flower V only
- (2) Flowers T and V
- (3) Flowers U and W
- (4) Flowers T, V and W

(Go on to the next page)

7 The diagrams below show fruits J, K and L from three different plants.

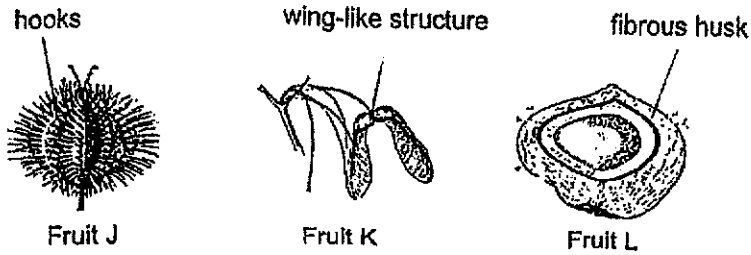

Which of the following matches the fruit to its method of dispersal?

| | Fruit J | Fruit K | Fruit L |
|-----|---------|-----------|---------|
| (1) | animal | wind | water |
| (2) | water | wind | animal |
| (3) | wind | splitting | animal |
| (4) | animal | splitting | wind |

8 The diagram below shows the female reproductive system in humans.

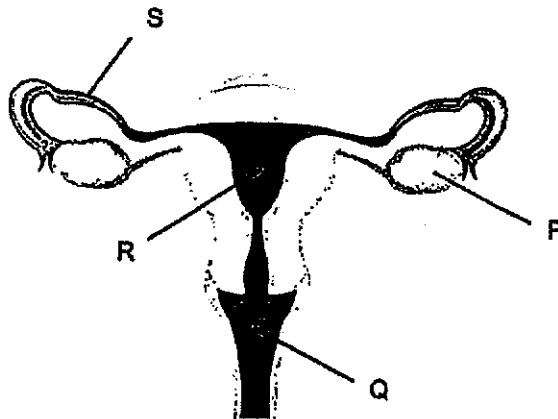

Which of the following matches the parts to the description?

| | Produces female reproductive cells | Where fertilised egg develops into a baby |
|-----|------------------------------------|---|
| (1) | P | R |
| (2) | S | R |
| (3) | P | Q |
| (4) | S | Q |

(Go on to the next page)

- 9 The graph below shows the composition of two gases, E and F, found in both the inhaled and exhaled air of a human.

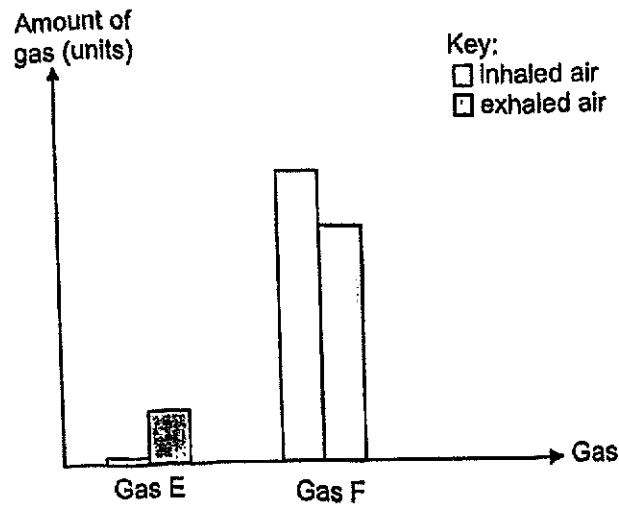

What could gases E and F be?

| | Gas E | Gas F |
|-----|----------------|----------------|
| (1) | carbon dioxide | water vapour |
| (2) | carbon dioxide | oxygen |
| (3) | oxygen | carbon dioxide |
| (4) | water vapour | carbon dioxide |

- 10 The table below shows some characteristics of two organisms, P and Q.

| Organism | Characteristics |
|----------|--------------------------------|
| P | Flowers are pollinated by wind |
| Q | Catches prey at night |

Based on the characteristics that the organisms have in the table above, which of the following adaptations must organisms P and Q have to help them to survive?

| | Organism P | Organism Q |
|-----|---|-----------------------------------|
| (1) | Flowers are brightly-coloured | Has good night vision |
| (2) | Flowers are dull-coloured | Has a long tail to balance itself |
| (3) | Anthers of flowers hang out of the petals | Has good sense of hearing |
| (4) | Flowers are either male or female | Has thick fur as body covering |

(Go on to the next page)

11 Study the food web below.

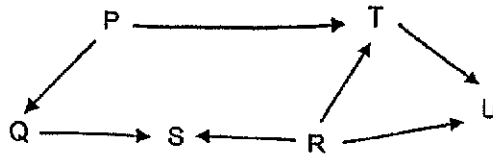

- A Q is both a predator and prey.
- B U is a food producer.
- C S is a plant-and-animal-eater
- D T is a plant-eater.

Which of the statements above are correct?

- (1) A and B only
- (2) A and D only
- (3) B and C only
- (4) C and D only

12 The diagram below shows a habitat with some living things.

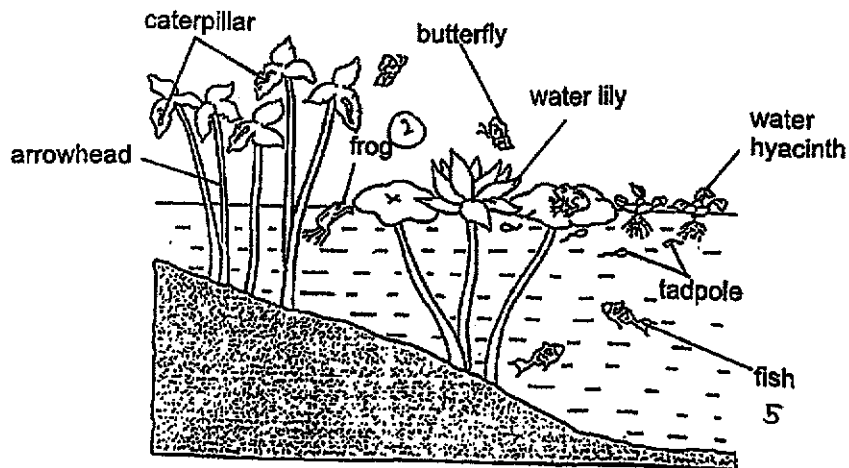

Based on the diagram above, which one of the following statements is correct?

- (1) There are two populations of producers.
- (2) There are five populations of consumers.
- (3) There is one community with six populations.
- (4) There is one community with eight populations.

(Go on to the next page)

13 Ahmad studied the effect of light on plant W. The diagrams below shows his observations when plant W is grown under different amount of light.

Low amount of light



High amount of light



Which set of graphs matches with the observations of plant W above?

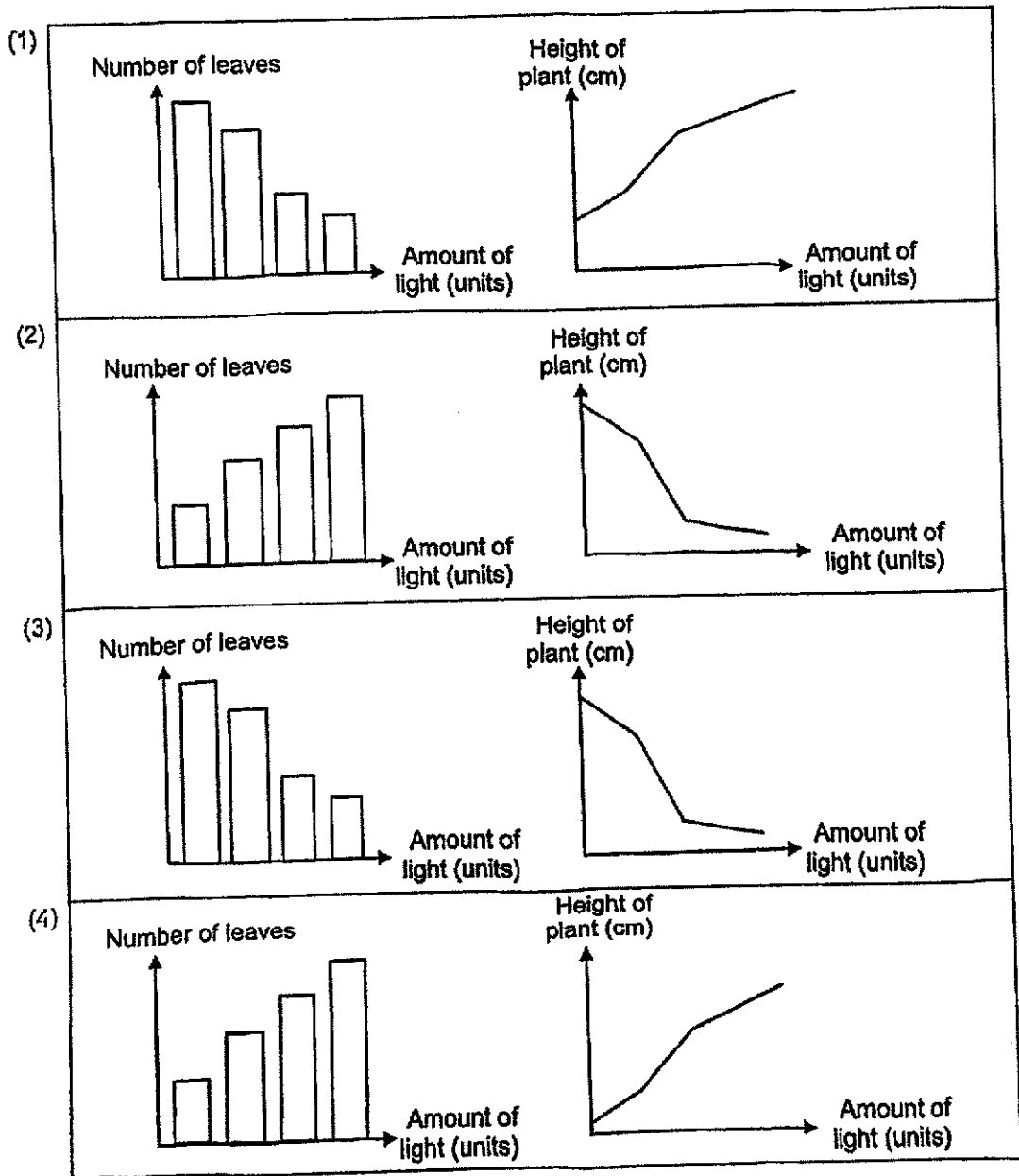

(Go on to the next page)

- 14 The diagram below shows how man's activities affect the environment.

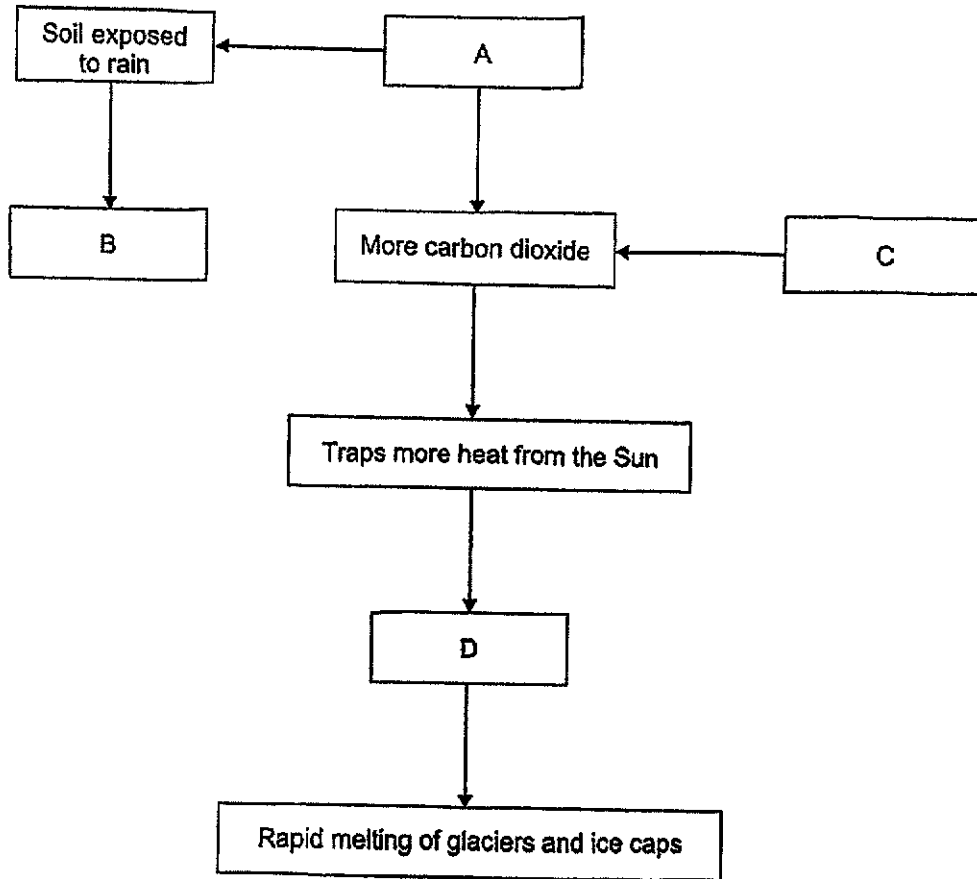

Which one of the following correctly represents A, B, C and D?

| | A | B | C | D |
|-----|----------------------|----------------------|----------------------|-------------------|
| (1) | Burning fossil fuels | Soil erosion | Deforestation | Greenhouse effect |
| (2) | Deforestation | Burning fossil fuels | Global warming | Greenhouse effect |
| (3) | Burning fossil fuels | Deforestation | Greenhouse effect | Global warming |
| (4) | Deforestation | Soil erosion | Burning fossil fuels | Global warming |

(Go on to the next page)

- 15 Jessica measured the mass of four similar objects made of materials, A, B, C and D, before placing them into a container of water. The objects were taken out after 10 minutes and their mass were measured again. She recorded the results in the table below.

| Materials | Mass at the start (g) | Mass after 10 minutes in water (g) |
|-----------|-----------------------|------------------------------------|
| A | 20 | 50 |
| B | 20 | 25 |
| C | 20 | 55 |
| D | 20 | 20 |

Study the picture of a diaper below.

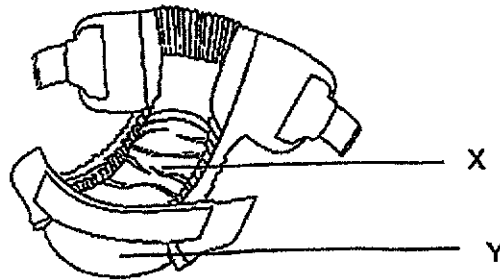

Which of the materials A, B, C or D are the most suitable to make parts X and Y of the diaper?

| | Part X | Part Y |
|-----|--------|--------|
| (1) | B | C |
| (2) | A | B |
| (3) | C | D |
| (4) | D | C |

(Go on to the next page)

- 16 Three 500 cm³ flasks, X, Y and Z, are connected to air pumps as shown in the diagram below.

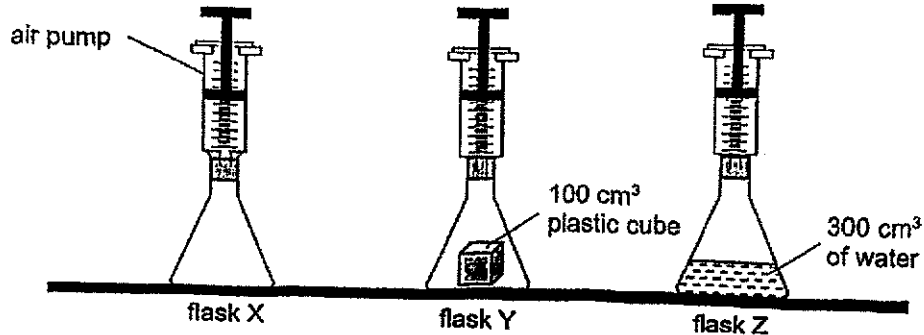

After another 300 cm³ of air is pumped into all flasks, which of the following correctly shows the final volume of air inside the flasks?

| | flask X (cm ³) | flask Y (cm ³) | flask Z (cm ³) |
|-----|----------------------------|----------------------------|----------------------------|
| (1) | 800 | 700 | 500 |
| (2) | 600 | 500 | 400 |
| (3) | 500 | 400 | 200 |
| (4) | 500 | 400 | 600 |

- 17 The graph below shows the changes in temperature when substance A is heated over a period of time. Substance A has a melting point at 28 °C and boiling point at 317°C.

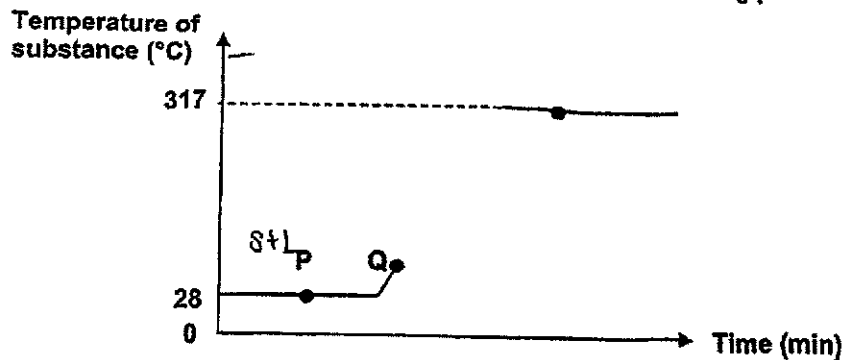

Which statement about substance A is not correct?

- (1) At 50°C, substance A is in liquid state.
- (2) At point P, substance A is in solid and liquid state.
- (3) At point Q, substance A is in solid and liquid state. X
- (4) At point R, substance A is in liquid and gaseous state.

(Go on to the next page)

- 18 Lily bought a bowl of iced dessert. She observed a white mist over the crushed ice.

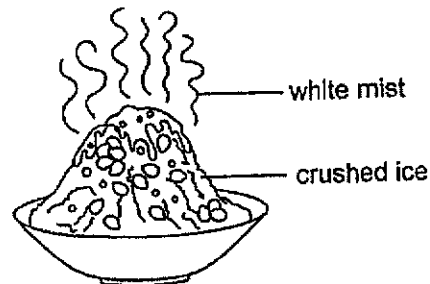

The arrows, A, B, C and D, below represent different processes.

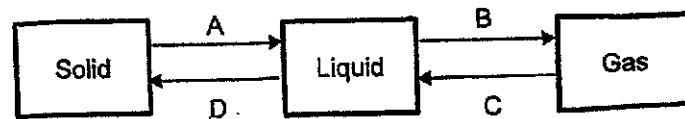

Which of the following is correct?

| | State of mist | Process that forms the mist |
|-----|---------------|-----------------------------|
| (1) | Gas | B |
| (2) | Liquid | C |
| (3) | Liquid | A |
| (4) | Solid | D |

- 19 Three circuits, A, B and C were set up as shown in the diagram below. All the components are in working condition. In which circuit(s) will a bulb light up?

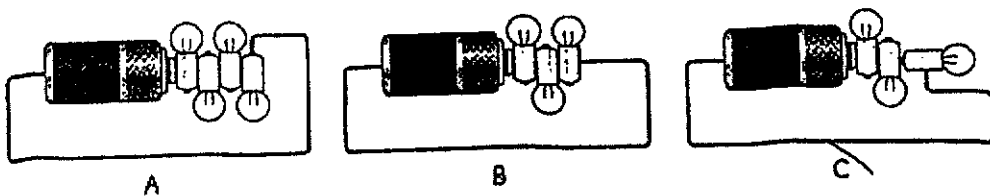

- (1) A only
 (2) B and C only
 (3) A and C only
 (4) None of the above

(Go on to the next page)

- 20 John placed two identical ice cubes on two blocks made of materials X and Y as shown in the diagram below. The blocks were of similar size.

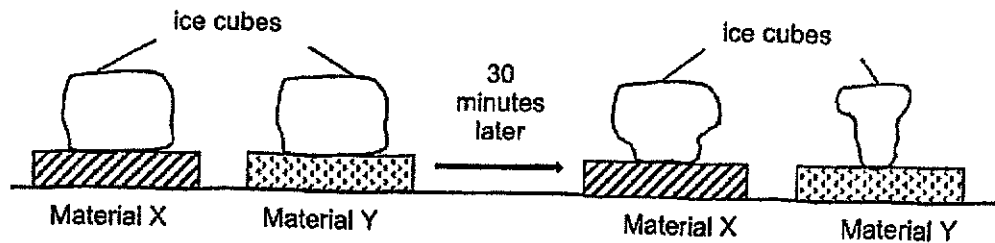

The ice cubes were placed at room temperature and after 30 minutes, John observed that the ice cube on material Y was smaller.

Which of the following is correct about materials X and Y?

- (1) Material Y loses heat slower to the ice than X.
 - (2) Material X gains heat from the ice faster than Y.
 - (3) Material X should be used to keep cold items cool.
 - (4) Material Y should be used to keep hot items warm.
- 21 Which of the following is not an example of energy conversion?
- (1) climbing up the stairs
 - (2) cooling hot water in a glass
 - (3) lighting a candle with a matchstick
 - (4) generating electricity in a power station

22 A compass has a magnet that rotates freely as shown below.

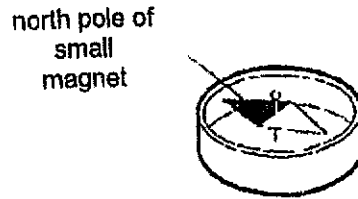

There were four bar magnets. A compass was placed near end P and the direction of the compass needle was as shown below.

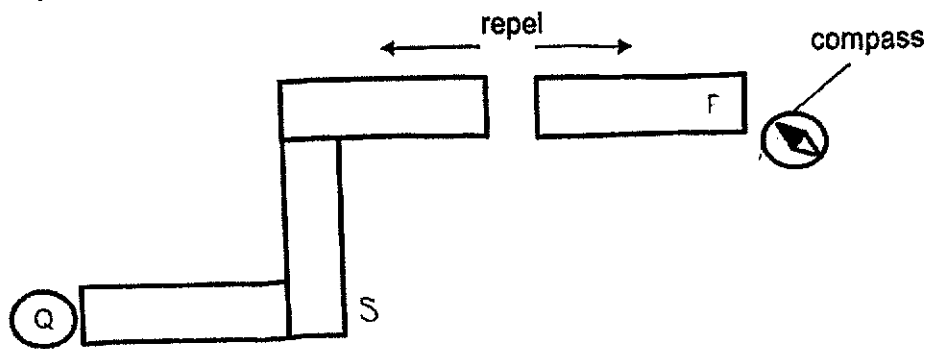

What would be the direction of the needle when the compass was placed at Q?

- (1) (2) (3) (4)

23 All the bulbs, P, Q, R and S are lit in the following circuit.

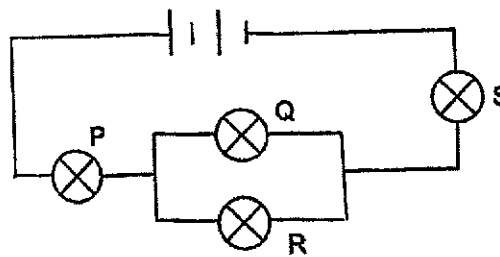

If one bulb fuses, what is the least and most number of bulb(s) remaining lit?

| | Least | Most |
|-----|-------|------|
| (1) | 1 | 2 |
| (2) | 2 | 2 |
| (3) | 0 | 0 |
| (4) | 0 | 3 |

(Go on to the next page)

24 John was standing directly under the lamp at position A. He walked in a straight line from A to C and back from C to B as shown below.

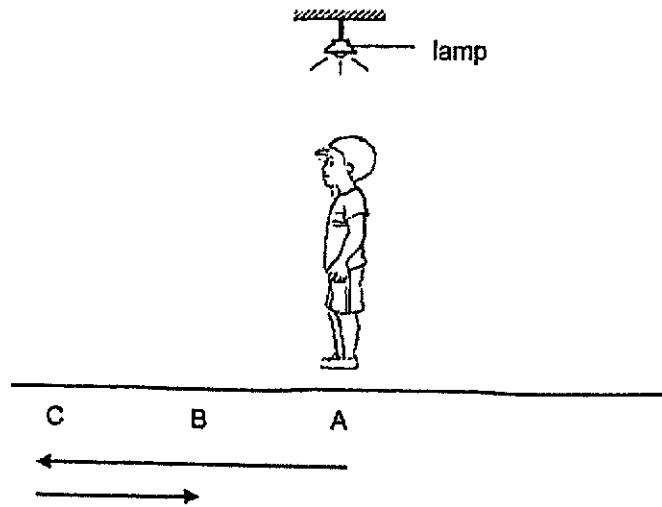

Which graph shows the length of his shadow changed during this time?

(1)

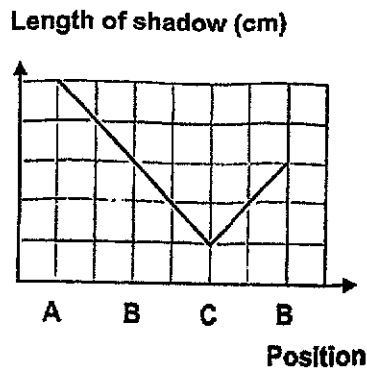

(2)

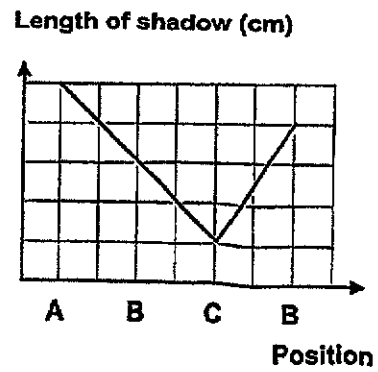

(3)

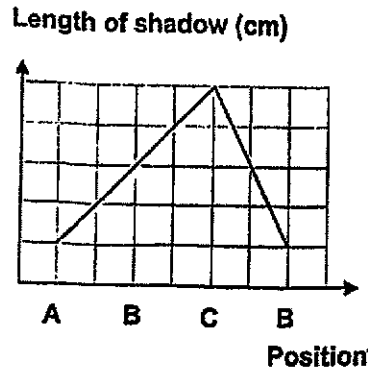

(4)

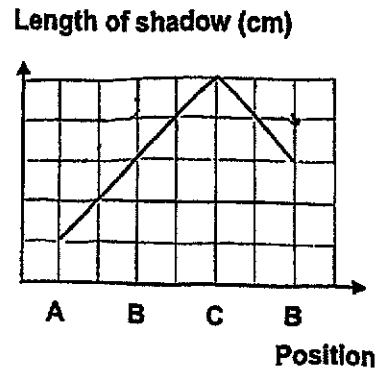

(Go on to the next page)

- 25 Ian went to the beach and observed some coconut trees. He saw that one of the coconuts had fallen from a tree and landed on the sand.

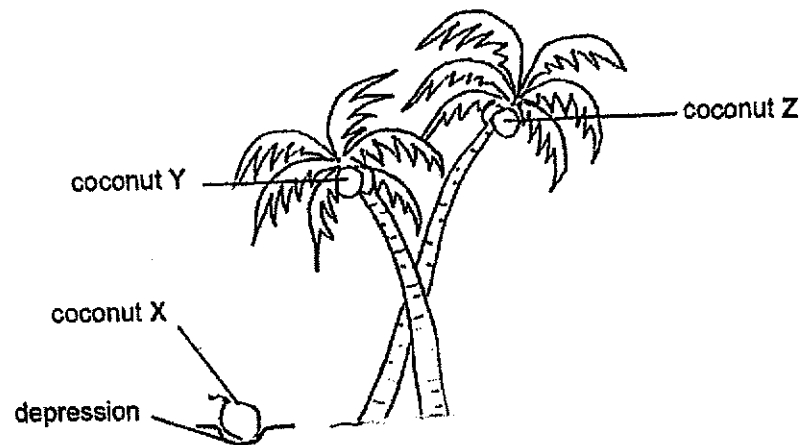

Based on the diagram above, which of the following statements is correct?

- (1) Coconut X has the least amount of gravitational force acting on it since it is on the ground.
- (2) Coconut X does not possess any gravitational potential energy as it was lying on the ground.
- (3) Coconut Y and Z have the same amount of gravitational potential energy if they are of the same mass.
- (4) Coconut Z has greater gravitational force acting on it than on Y because coconut Z was further away from the ground.

(Go on to the next page)

- 26 Two springs, M and N, have the same length. When two identical blocks are hung on the springs, the results are as shown.

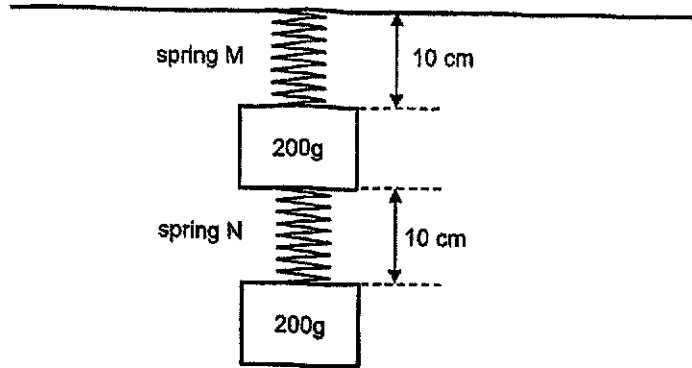

Which graph shows the relationship between the mass hung on the spring and the length of springs, M and N?

(1) Length of Spring (cm)

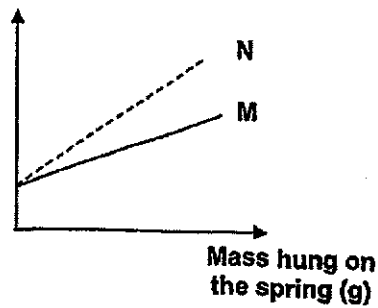

(2) Length of Spring (cm)

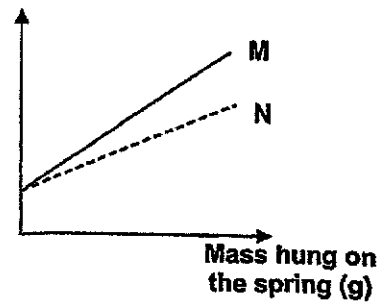

(3) Length of Spring (cm)

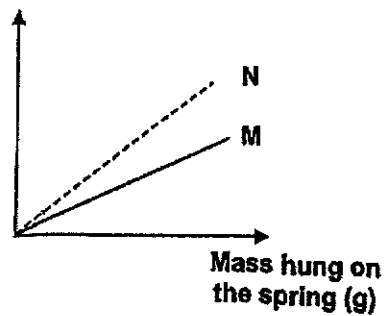

(4) Length of Spring (cm)

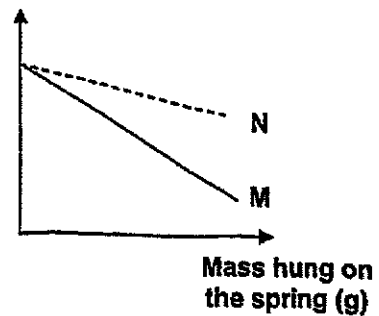

(Go on to the next page)

- 27 Hui Min released a ball tied to a string from position A.

The ball passed through position B and reached position C as shown in diagram 1. From position C, the ball swung back to position B as shown in diagram 2.

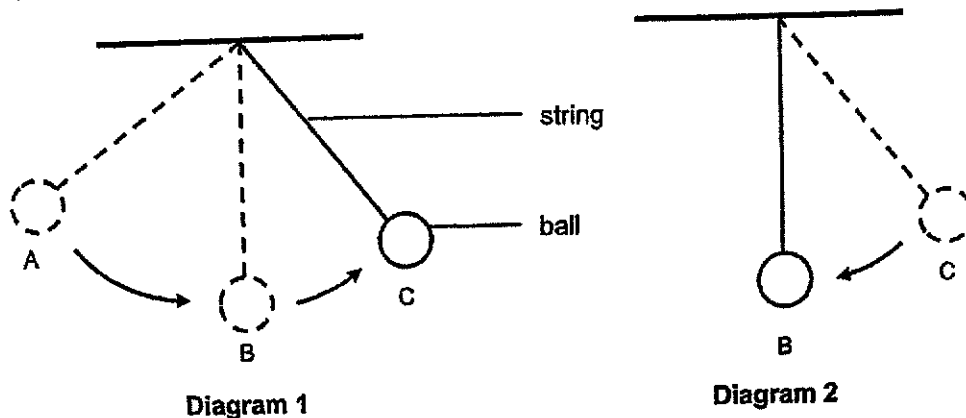

Which of the following about the energy in the ball is correct?

| | Potential energy at position A compared to position C | Kinetic energy at position B in diagram 2 as compared to diagram 1 |
|-----|---|--|
| (1) | less | more |
| (2) | less | less |
| (3) | more | less |
| (4) | more | more |

(Go on to the next page)

- 28 Ethan used the set-up shown to investigate the force needed to pull an object across different types of materials.

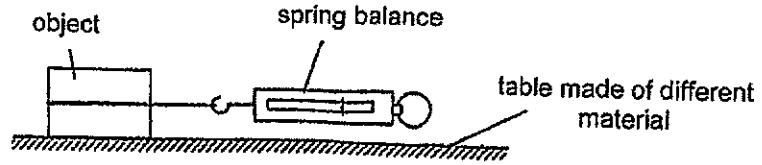

His results were as shown.

| Material | Force needed (units) |
|----------|----------------------|
| A | 5.5 |
| B | 2.5 |
| C | 7.5 |

Ethan wanted to push a box onto the stage using a ramp as shown in the diagram below.

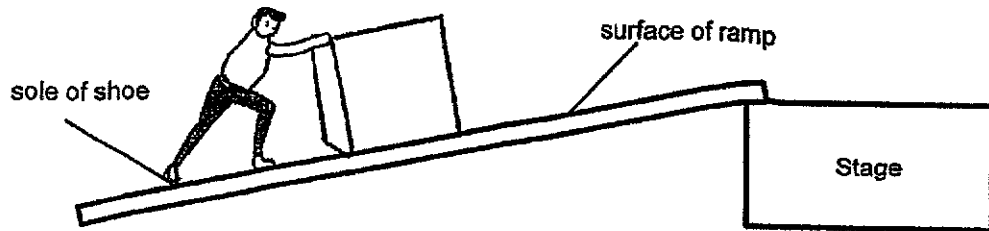

Based on the above results, which material is most suitable for making the sole of his shoes and the surface of the ramp?

| | Sole of shoe | Surface of ramp |
|-----|--------------|-----------------|
| (1) | Material B | Material B |
| (2) | Material B | Material C |
| (3) | Material C | Material A |
| (4) | Material C | Material B |

METHODIST GIRLS' SCHOOL
Founded In 1887



PRELIMINARY EXAMINATION 2024
PRIMARY 6
SCIENCE

BOOKLET B

Total Time for Booklets A and B: 1 hour 45 minutes

INSTRUCTIONS TO CANDIDATES

Do not turn over this page until you are told to do so.

Follow all instructions carefully.

Answer all questions.

Name: _____ ()

Class: Primary 6. _ ____

Date : 21 August 2024

| | |
|--------------------|-----|
| Booklet A | 56 |
| Booklet B | 44 |
| Total | 100 |
| Parent's Signature | |

This booklet consists of 15 printed pages including this page.

For questions 29 to 40, write your answers in the spaces provided. The number of marks available is shown in brackets [] at the end of each question or part question. [44 marks]

29 The diagram below shows the life cycle of a mosquito.

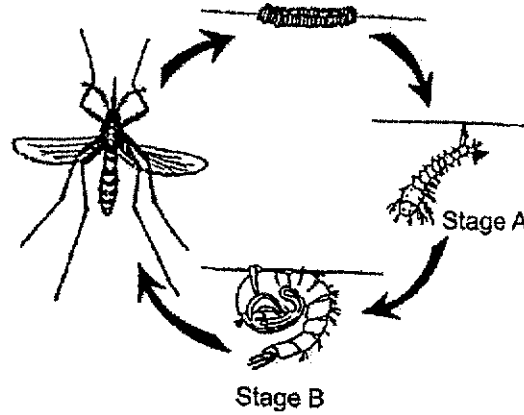

(a) Name Stage A. State one difference between stages A and B. [1]

(b) Male mosquitoes feed on the flower nectar of plant T.



Explain how male mosquitoes help to ensure that the life cycle of plant T continues. [2]

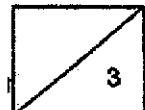

(Go on to the next page)

- 30 Jayna conducted an experiment to find out how the amount of plants affect the amount of soil collected. All the troughs contained the same amount of garden soil at the start.

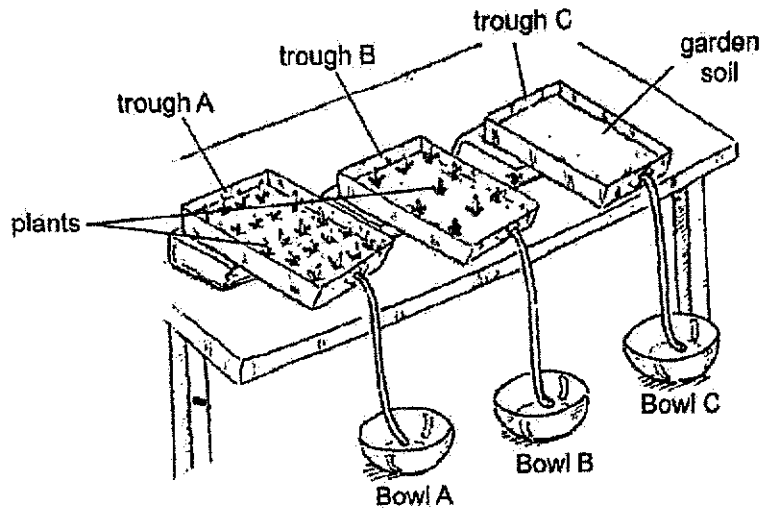

- (a) Jayna poured 500 cm³ of water into each trough and observed the amount of soil that was collected in bowls A, B and C.

Which bowl, A or B, will have a smaller amount of soil in it? Explain your answer. [1]

- (b) State the purpose of trough C. [1]

- (c) The picture below shows a river flowing downstream. Along the river, there is a factory.

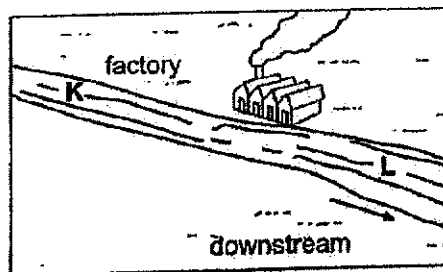

Explain why more dead fish were found in the river at L than at K. [1]

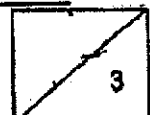

(Go on to the next page)

31 The diagram below shows how blood is transported in the human circulatory system.

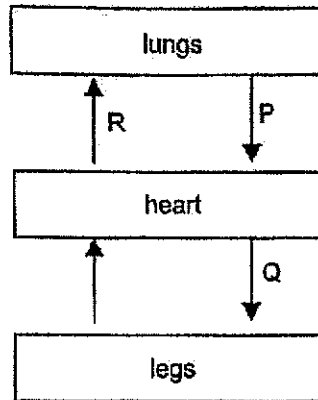

(a) Complete the bar graph below to show the amount of oxygen in the blood at P and R. [1]

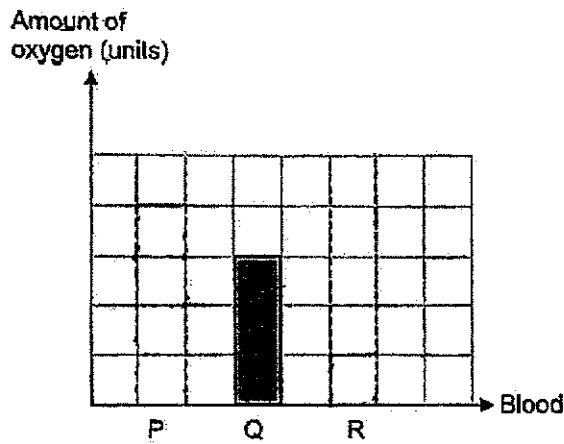

(b) Name three parts found in the human circulatory system. [1]

(c) Describe how the digestive system works together with the circulatory system. [2]

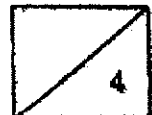

(Go on to the next page)

32 Sea anemones are marine animals that feed on small fish and shrimps. When the prey comes close, the sea anemone attacks it using its poisonous tentacles.

The clownfish, not affected by the poisonous tentacles of the sea anemone, helps to clean up the sea anemone by feeding on the leftovers of what the sea anemone feeds on.

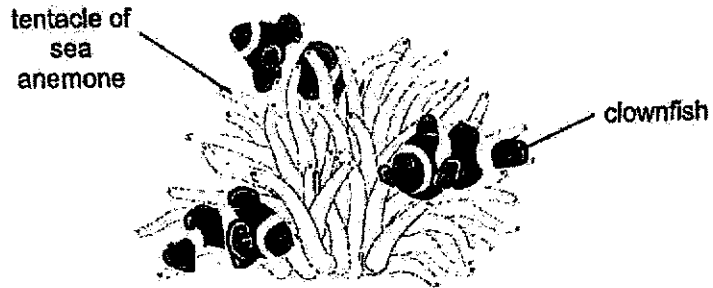

(a) State one way in which the clownfish depends on the sea anemone for survival. [1]

(b) Sea slugs feed on the sea anemone. Explain how the population of the clownfish changes when the population of the sea slug increases. [2]

(c) Green algae is commonly found living inside the sea anemone. Suggest one way in which the sea anemone benefits from the algae. [1]

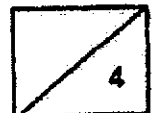

(Go on to the next page)

6

33 The diagram below shows a penguin.



When the weather gets very cold, penguins puff their feathers to trap air.

(a) Explain how puffing its feathers helps the penguin to keep warm.

[1]

(b) Penguins spend most of their time swimming in the dark ocean water.



black feathers

(i) State a characteristic of the penguin and explain how this affects its movement in water.

[1]

(ii) Suggest how the black feathers is an advantage for the penguins swimming in the dark ocean water.

[1]



(Go on to the next page)

7

- 34 Pam put a pondweed into a clear test-tube of water placed 10 cm from the lamp. She switched on the lamp and measured the volume of gas produced in 5 minutes.

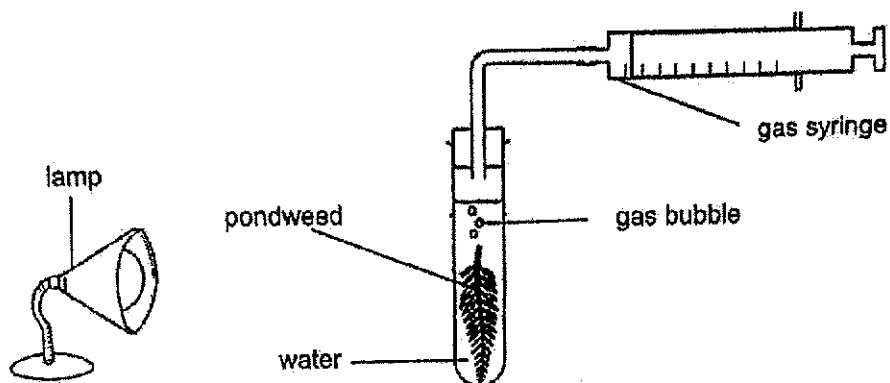

Pam repeated the experiments using fresh sets of water and pondweed. She placed the lamp at different distances from the pondweed and her results are as shown.

| Distance of lamp from pondweed (cm) | Volume of gas produced (cm ³) |
|-------------------------------------|---|
| 10 | 80 |
| 35 | 65 |
| 75 | 29 |
| 100 | 7 |
| 150 | 0 |

- (a) How does the volume of gas produced change with the distance of the lamp from the pondweed? [1]

- (b) Explain your answer in (a). [1]

- (c) Suggest one thing Pam could do to obtain more reliable results. [1]

(Go on to the next page)

Using the same set-up, Pam conducted a second experiment using two different water plants, X and Y, that are similar in size. She measured the volume of gas produced and plotted the results as shown in the graphs below.

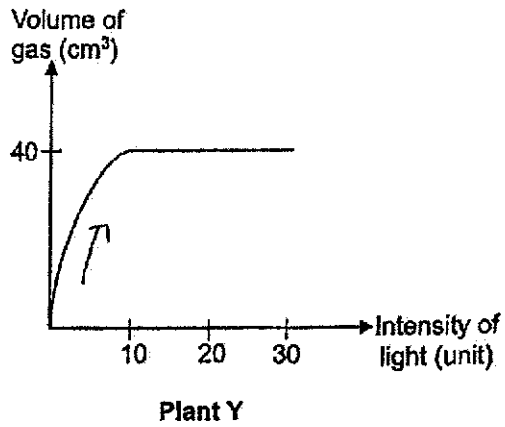
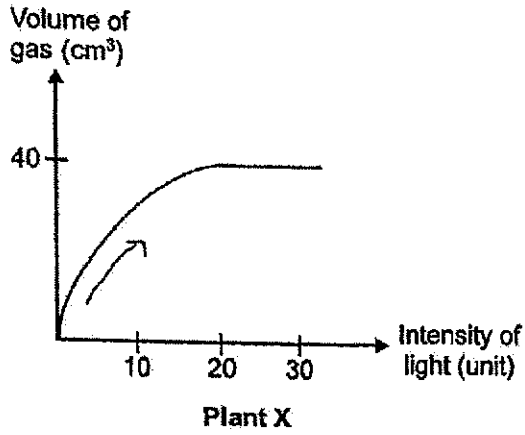

- (d) Based on the results of her second experiment, which water plant, X or Y, will survive better in the shady part of her pond? Explain your answer. [2]



(Go on to the next page)

35 Chetra poured water into the ice-cube tray as shown below.

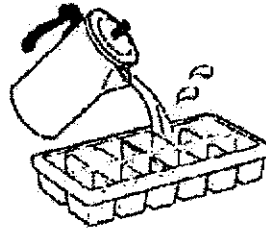

The table below showed the temperature for two different compartments of her refrigerator.

| Compartment | Temperature of the compartment (°C) |
|-------------|-------------------------------------|
| A | Below 0 |
| B | 3 |

(a) Which compartment, A or B, should she put to turn the water into ice? Explain your answer. [1]

Chetra had some cubes of pure chocolate. She placed these cubes in a beaker and melted them as shown below.

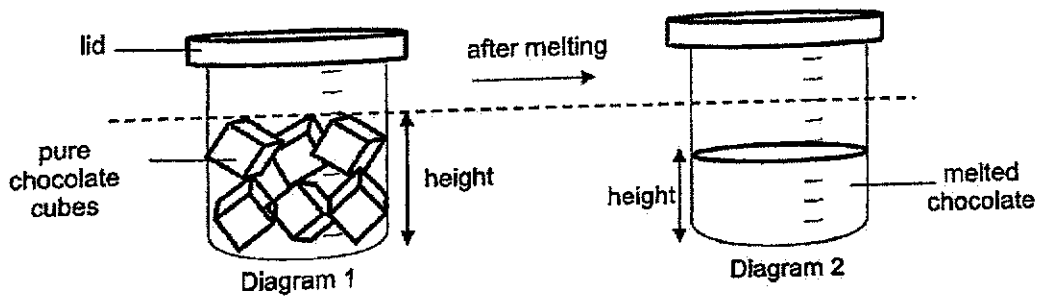

(b) Explain why the height of melted chocolate was different from the original height of the chocolate cubes in the beaker. [1]

(c) Chetra concluded that the volume of chocolate cubes in diagram 1 was greater than the volume of melted chocolate in diagram 2. Do you agree? Give a reason for your answer. [1]

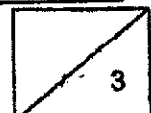

(Go on to the next page)

- 36 Jean conducted an experiment in the same room using two similar beakers containing the same amount of water but at different temperature.

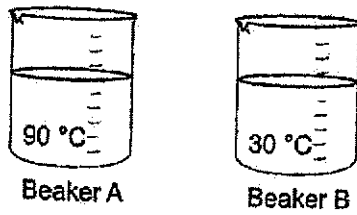

The graph showed the amount of water left in the beakers over a period of time.

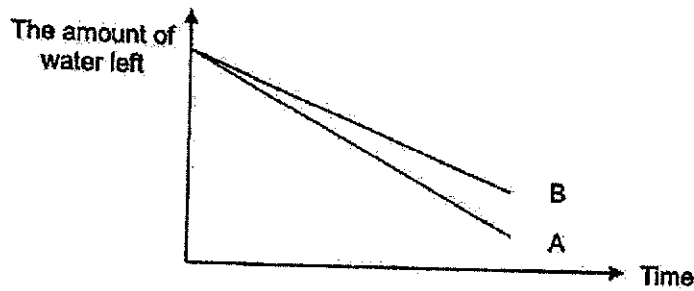

- (a) Based on the above results, explain how the temperature of the water affected the amount of water left in the beakers. [1]
-
-
- (b) Explain why Jean had to put the beakers in the same location for the experiment to be fair. [1]
-
-
- (c) Jean would like to find out how the size of exposed surface area affected the water loss. State two changes that she needed to make to the beakers. [1]
-
-



(Go on to the next page)

- 37 (a) State what frictional force is.

[1]

Timothy played table hockey with his sister. He used the handheld mallet to push the puck to the other side.

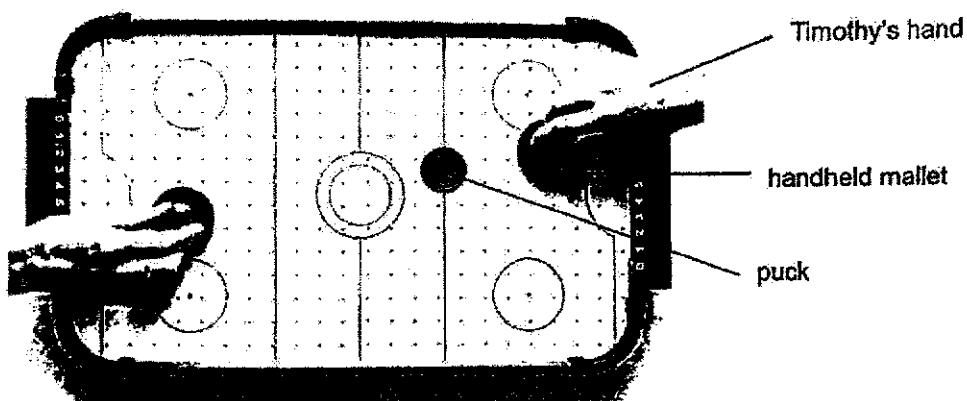

He had two pucks, P and Q, of different sizes as shown below. They were made of same material and had the same mass.



P (10 g)



Q (10 g)

- (b) Suggest if puck Q would travel further than P when Timothy, using the same amount of force, pushed it with the handheld mallet. Give a reason for your answer. [2]

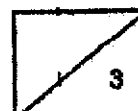

(Go on to the next page)

- 38 Xiao Jie hung ball A with a string above the ground as shown below. When the string was cut, the ball dropped and hit the ground.

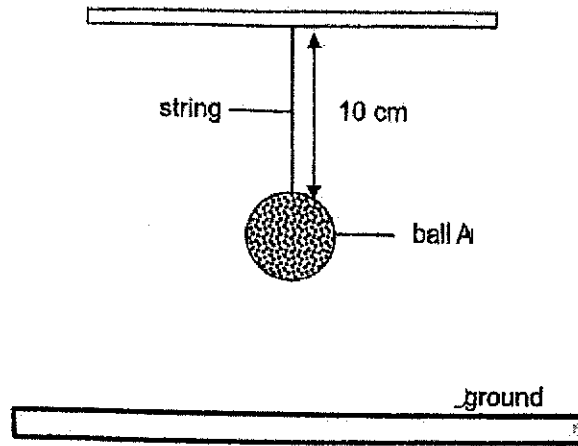

- (a) Fill in the boxes below to show the energy conversion when the string was cut from ball A. [2]

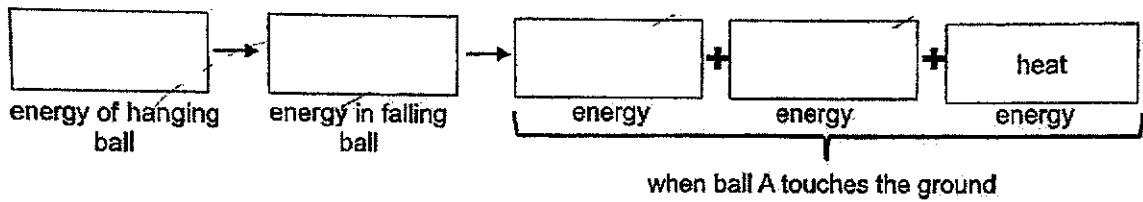

- (b) Suggest if the ball would produce a louder or softer sound if the length of string was 5 cm. Explain in terms of energy conversion. [2]

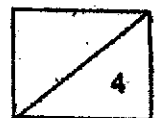

(Go on to the next page)

39 Study the following circuit diagram of a bread toaster. When the switch is open, the spring attached to bar X and the iron cylinder is at its original length.

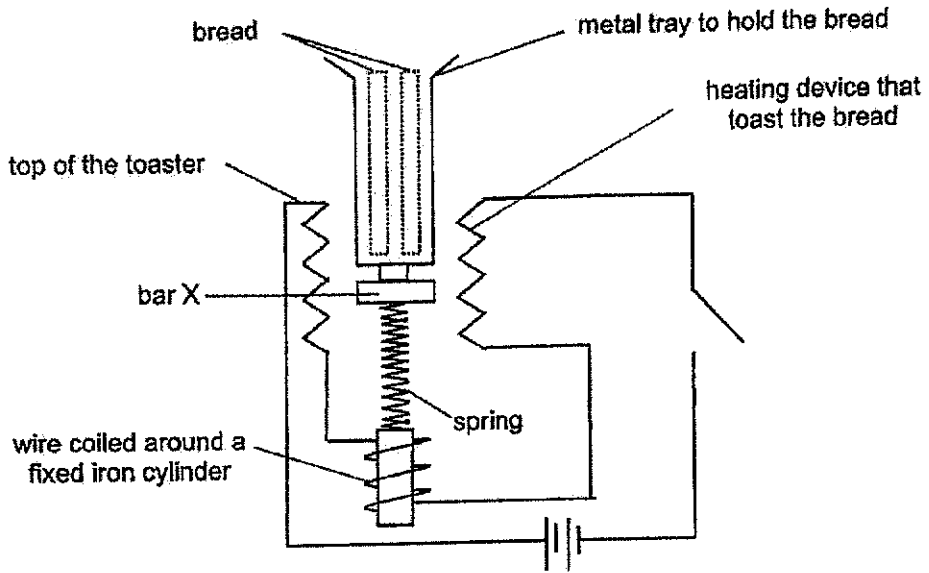

(a) When the switch was closed, the metal tray moved downwards. Suggest the property of bar X that made this happen. [1]

(b) Explain how the metal tray moved downwards when the switch was closed. [2]

(c) It was observed that part of the bread was still above the top of the bread toaster when the switch was closed. Suggest a change to the spring to make the metal tray move down completely. Explain your answer. [2]

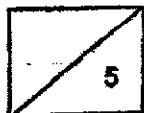

(Go on to the next page)

40 Grace had two bulbs controlled by one switch in her toy house as shown below.

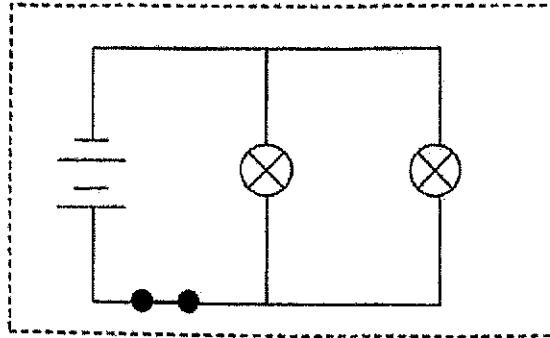

(a) When the switch was closed, the light was too bright for her. Without removing or adding any battery or bulb, what could she do to the circuit to make bulbs dimmer? Draw the new circuit in the following diagram. [1]

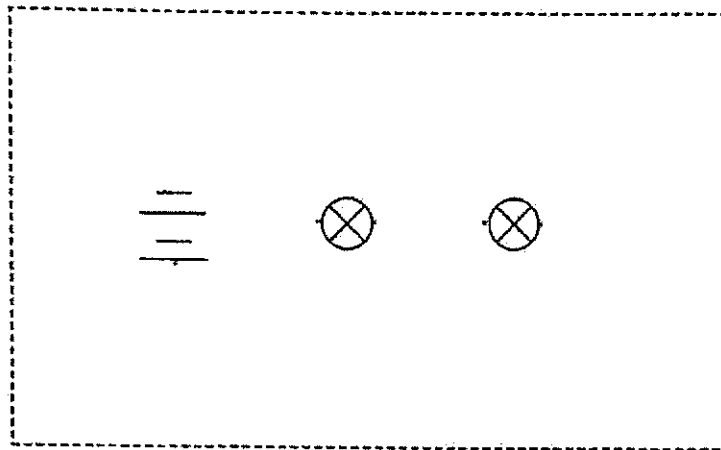

(b) State one disadvantage of the new arrangement of bulbs in part (a). [1]

- (c) Grace installed a two-way switch to control the light at the hallway. Each switch can be turned to position X or position Y.

She set up the circuit so that the bulb will be lit as described in the table below.

| Position of Switch | | Bulb Is lit |
|----------------------|------------------------|-------------|
| Switch on the ground | Switch at second floor | |
| X | Y | No |
| X | X | Yes |
| Y | Y | Yes |
| Y | X | No |

The diagram below shows part of the circuit. Complete the circuit so that it will work as described. [2]

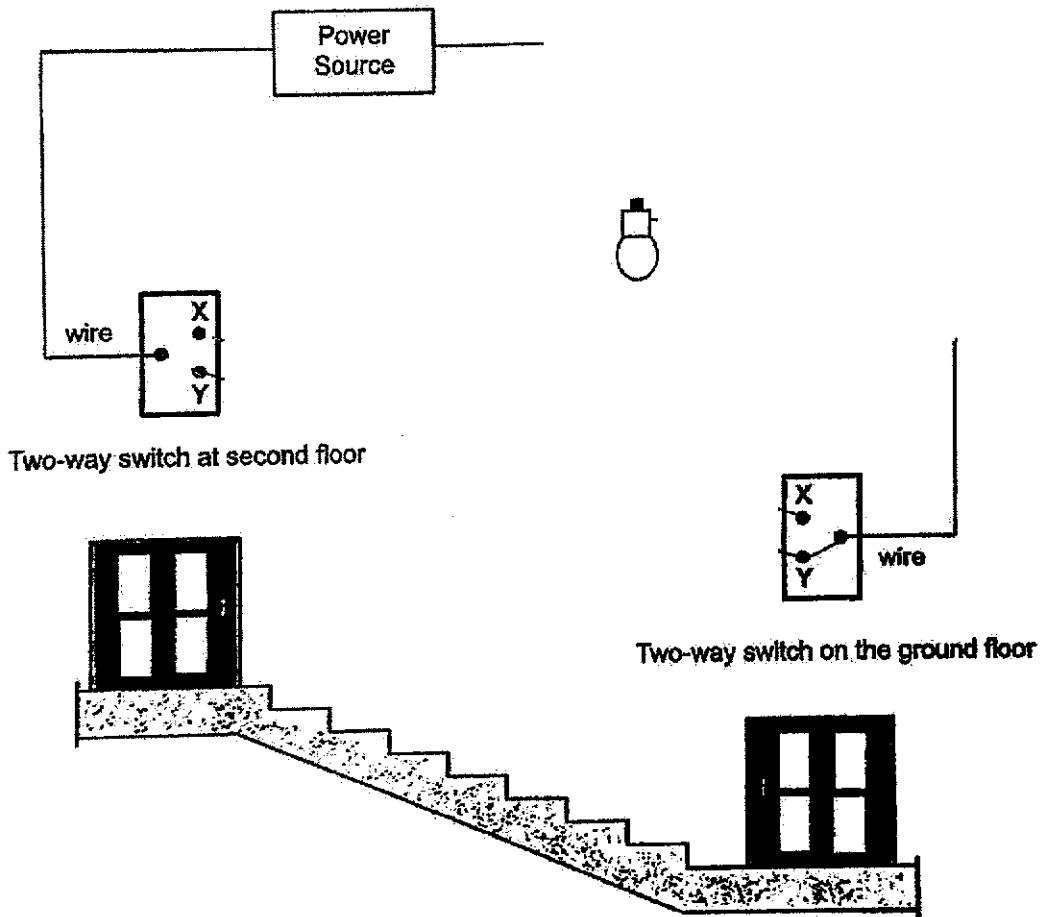

End of Paper



SCHOOL : MGS PRIMARY SCHOOL
LEVEL : PRIMARY
SUBJECT : SCIENCE
TERM : 2024 PRELIM

| | | | | | | | | | |
|-----|-----|-----|-----|-----|-----|-----|-----|-----|-----|
| Q 1 | Q2 | Q3 | Q4 | Q5 | Q6 | Q7 | Q8 | Q9 | Q10 |
| 1 | 4 | 1 | 4 | 2 | 2 | 1 | 1 | 2 | 3 |
| Q11 | Q12 | Q13 | Q14 | Q15 | Q16 | Q17 | Q18 | Q19 | Q20 |
| 4 | 3 | 2 | 4 | 3 | 3 | 3 | 2 | 3 | 3 |
| Q21 | Q22 | Q23 | Q24 | Q25 | Q26 | Q27 | Q28 | | |
| 2 | 1 | 4 | 4 | 2 | 1 | 3 | 4 | | |

Methodist Girls' School (Primary)
Suggested Answers for Preliminary Examination 2024

Section B

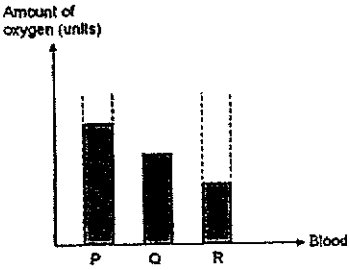
| | |
|-------|--|
| 29a | <p>Stage A is larva / wriggler.</p> <p>At stage A, the larva feeds on food / moults / moves but at Stage B, the pupa does not feed on food / does not moult / does not move.</p> |
| 29b | Male mosquitoes help to pollinate and fertilise the flower. The flower then develops into a fruit that contains seeds which grow into new plants. |
| 30a | <p>Bowl A. There are more plants in trough A so more roots are holding on to the soil, causing less soil to be eroded / washed away by the water and collected in bowl A.</p> <p>OR</p> <p>Bowl A. There are less plants in trough B so less roots are holding on to the soil, causing more soil to be eroded / washed away by the water and collected in bowl B.</p> |
| 30b | It is a control set-up to compare and confirm that any difference in the amount of soil collected is solely due to the number of plants in the trough. |
| 30c | The water at L contains more pollutants from the factory, so more fish die. |
| 31a | <p>Amount of oxygen (units)</p>  <p style="text-align: center;">P Q R → Blood</p> |
| 31b | Heart, blood, blood vessels |
| 31c | Digested food is absorbed into the blood in the small intestine. Heart pumps blood containing digested food to all parts of the body in the circulatory system. |
| 32a | The clownfish depends on the sea anemone for shelter / protection / food. |
| 32b | When the population of sea slug increases, more sea slugs will prey / feed on sea anemone leading to a decrease in the population / number / amount of sea anemone. With less sea anemone, there will be less food / shelter for the clownfish, hence the population of clownfish will decrease. |
| 32c | During photosynthesis, algae produces oxygen for sea anemone to take in. OR Algae attracts small fishes / shrimps to feed on so the sea anemone can prey on them. |
| 33a | Puffing their feathers traps air which is a poor conductor of heat which decreases / reduces / slows down heat loss from the penguin's body to the surroundings. |
| 33bi | <p>Penguin has a streamlined body which helps it to swim faster. OR</p> <p>Penguin has modified wings/ flippers / webbed feet which helps it to swim faster.</p> |
| 33bii | <p>The black feathers help penguins to blend in / camouflage with the dark ocean water, so it is less likely to be spotted / seen and eaten by its predators.</p> <p>OR</p> <p>The black feathers help penguins to blend in / camouflage with the dark ocean water, less likely to be spotted / seen by its prey, increasing the chances of them obtaining food / catching prey.</p> |

| | |
|-----|---|
| 34a | As the distance of the lamp from the pondweed increases / decreases, the volume of gas produced decreases / increases. |
| 34b | As the distance of the lamp from the pondweed increases, the intensity / amount of light decreases so the rate of photosynthesis decreases. |
| 34c | Repeat the experiment three or more times and calculate the average result. |
| 34d | Plant Y. For the same intensity of light of 10 units, plant Y produces more gas than Plant X, so plant Y can make food / photosynthesise with less light in a shady area. OR To produce the same volume of gas of 40 units, plant Y needs less light than Plant X, so plant Y can make food / photosynthesise with less light in a shady area. |
| 35a | Compartment A. Water has a freezing point of 0°C and compartment B is above 0°C |
| 35b | Chocolate cubes/solids have definite shape and there are air spaces between the chocolate cubes. OR Melted chocolate/Liquid has indefinite shape and it can change the shape to occupy /fill up all the air spaces between the chocolate cubes. |
| 35c | No. Both solid (chocolate cubes) and liquid (melted chocolates) have definite volume. The volume will remain the same even when it changes its state. |
| 36a | As the temperature of water increases, the rate of evaporation increases and hence less water is left. |
| 36b | It is to ensure that the temperature of the surroundings or the amount / strength of wind in the surroundings is the same and the amount of water loss is only due to differences in temperature of water and not the differences in temperature /presence of wind at the location. OR There should be only one changed variable which is the temperature of water, and the surrounding temperature/amount /strength of wind at the location must be kept the same. |
| 36c | She should make the temperature of water in both beakers the same and change one of the beakers with a bigger opening to have a bigger exposed surface area. |
| 37a | It is the force that opposes/ moves against motion. |
| 37b | No. Both P and Q had the same mass/weight, so the amount of frictional force between the puck and the table is the same. The surface area of the pucks would not affect the amount of frictional force between the puck and the table. Both will travel the same distance. |
| 38a | (Gravitational) Potential energy in the hanging ball → Kinetic energy in the falling ball → Kinetic + Sound energy + Heat energy of the ball on the ground |
| 38b | Louder. Shorter string will hang the ball higher from the ground, resulting in more (gravitational) potential energy of the ball which could be converted to more kinetic energy of the falling ball which will be converted to more sound energy. |
| 39a | Magnetic material |
| 39b | When the switch is closed, the iron cylinder becomes an electromagnet/ is magnetized which will attract bar X and pull the metal tray downwards. |

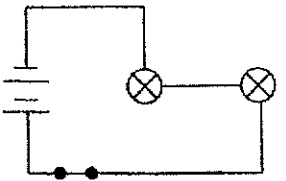
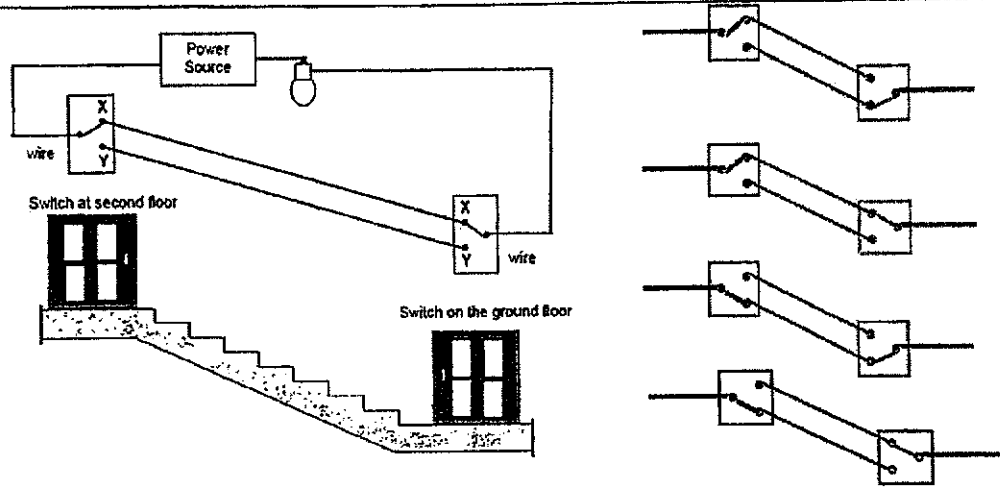
| | |
|------------|--|
| <p>39c</p> | <p>Use a less stiff spring For the same force / magnetic force of attraction applied, less stiff spring will be compressed more and it will move downwards more/ move further down.</p> <p>Use a shorter spring. For the same force / magnetic force of attraction applied, the tray will be lower / closer to the cylinder at the start and it will move downwards more/ move further down.</p> |
| <p>40a</p> |  |
| <p>40b</p> | <p>She could not control the bulb independently because there is only one switch. OR If the switch is closed, both will light up at the same time. OR If the switch was open, both will not light up. OR If one bulb fuses, the other bulb cannot light up.</p> |
| <p>40c</p> |  |