

METHODIST GIRLS' SCHOOL

Founded in 1887



PRELIMINARY EXAMINATION 2019 PRIMARY 6 SCIENCE

BOOKLET A

Total Time for Booklets A and B: 1 hour 45 minutes

INSTRUCTIONS TO CANDIDATES

Do not turn over this page until you are told to do so.

Follow all instructions carefully.

Answer all questions.

Shade your answers in the Optical Answer Sheet (OAS) provided.

Name: _____ ()

Class: Primary 6. _____

Date : 22 August 2019

For each question from 1 to 28, four options are given. One of them is the correct answer. Make your choice (1, 2, 3 or 4). Shade the correct oval on the Optical Answer Sheet (OAS).

[56 marks]

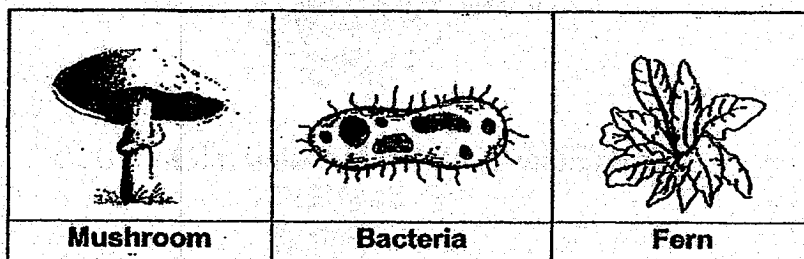

1 Study the three organisms as shown below.



Which statement is correct?

- (1) They can make food.
- (2) They respond to changes.
- (3) They reproduce by spores.
- (4) They can break down dead matter.

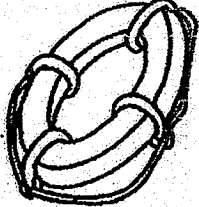
2 Study the classification table below.

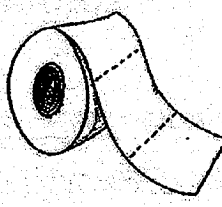
| Group X | | Group Y | |
|---|---|--|---|
|  |  |  |  |
| wine glass | swimming float | cotton socks | paper towel |

Which of the following properties are used to classify the objects into Group X and Group Y?

| | Group X | Group Y |
|-----|---------------------------|--------------------------------|
| (1) | Stiff and float in water | Flexible and absorbent |
| (2) | Strong and float in water | Break easily and sink in water |
| (3) | Waterproof and strong | Absorbent and flexible |
| (4) | Transparent and stiff | Opaque and flexible |

- 3 The diagram below shows a seedling and its adult plant.

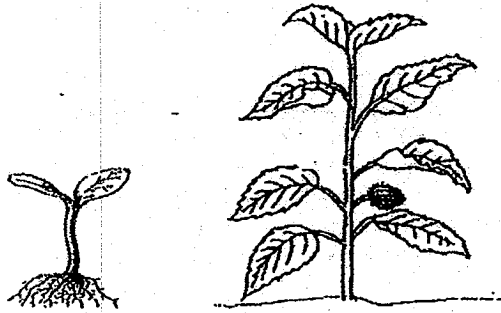

Which one of the following statements is **not** true?

- (1) Both have strong stems.
- (2) Both cannot bear flowers.
- (3) Both can make their own food.
- (4) The adult plant bears fruits but not the seedling.

- 4 Gopal observed two insects, S and T, and recorded his observations below.

| Characteristics | Insect S | Insect T |
|--|----------|----------|
| It has three body parts | ✓ | ✓ |
| Part of its life cycle is spent in water | ✓ | |
| The young resembles the adult | | ✓ |

Which of the following insects did Gopal observe?

| | Insect S | Insect T |
|-----|-----------|-------------|
| (1) | mosquito | cockroach |
| (2) | dragonfly | mosquito |
| (3) | frog | dragonfly |
| (4) | butterfly | grasshopper |

- 5 The diagram below shows the different organs, W, X, Y and Z, of a human digestive system.

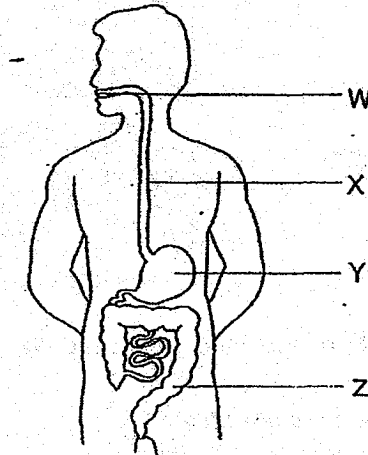

What of the following shows the correct function for each organ?

| | Food is further digested into a soupy mix | Food is broken into smaller substances | Water is removed from the undigested food | Partially digested food moves into the stomach |
|-----|---|--|---|--|
| (1) | Y | W | X | Z |
| (2) | Z | W | Y | X |
| (3) | Y | W | Z | X |
| (4) | X | Y | Z | W |

- 6 Joshua used two identical syringes for an experiment. One syringe was filled with 50 cm³ of oil while the other was filled with 50 cm³ of air.

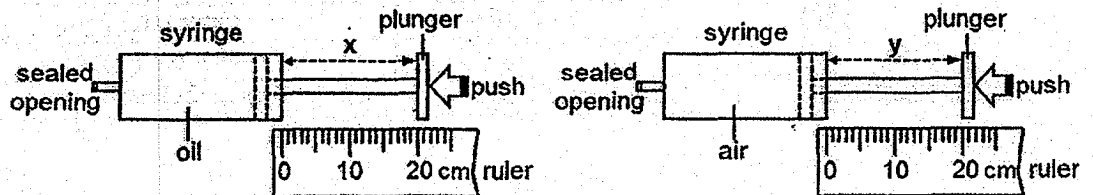

He pushed each plunger as hard as he could and measured distance x and distance y.

Which of the following shows the correct values of x and y?

| | x (cm) | y (cm) |
|-----|--------|--------|
| (1) | 0 | 10 |
| (2) | 5 | 20 |
| (3) | 10 | 0 |
| (4) | 20 | 5 |

- 7 A pump was connected to a flask as shown below. It was able to pump 50 cm^3 of air into the flask each time the plunger was pushed in completely.

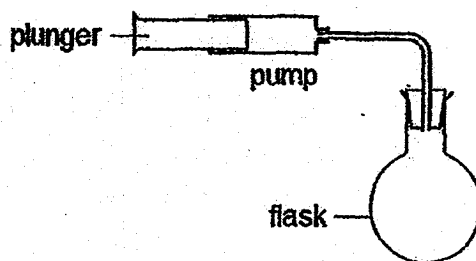

Which of the following pair of graphs show the mass and volume of the air in the flask as air was continually pumped into the flask?

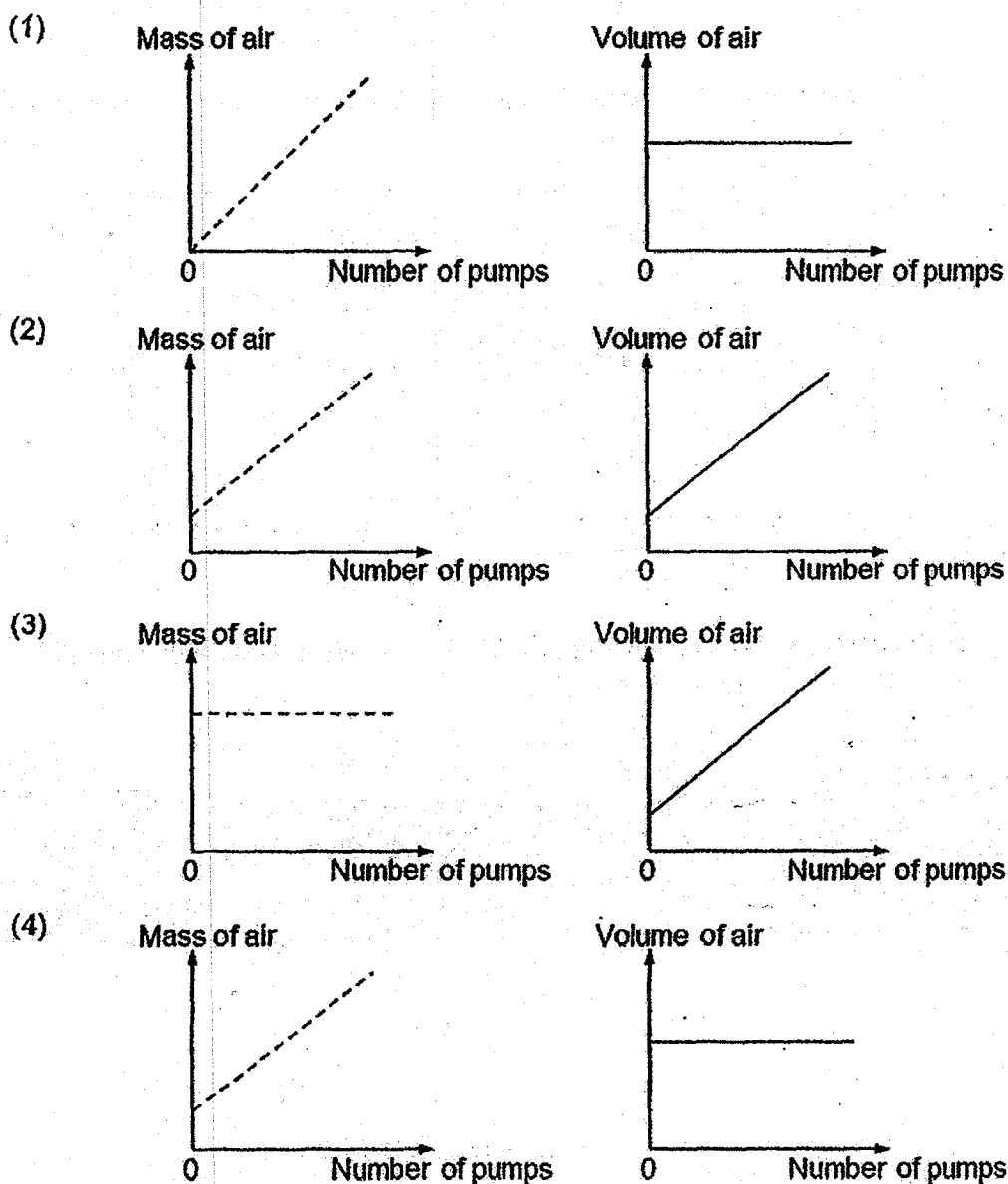

- 8 Three different types of flowering plants, A, B and C, were growing in fields near a river as shown in Diagram 1.

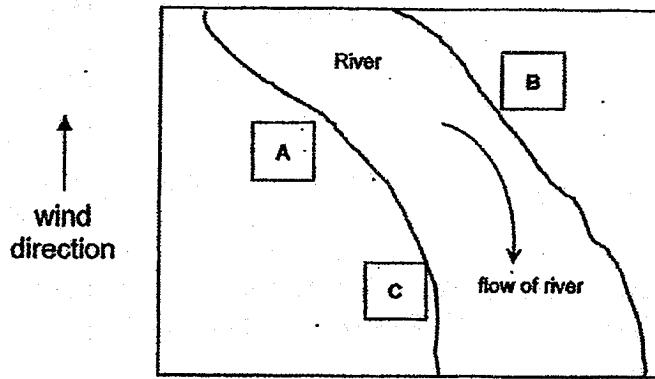

Diagram 1

A few years later, more of each plant, A, B and C, were found growing in the fields as shown in Diagram 2.

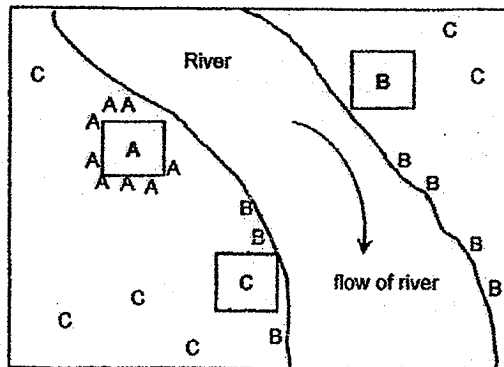

Diagram 2

What are the likely characteristics of the fruits of plants A, B and C, which helped them to disperse their seeds?

| | Plant A | Plant B | Plant C |
|-----|-----------------------|-----------------------|----------------------|
| (1) | fleshy and edible | splits open when ripe | hook-like structures |
| (2) | splits open when ripe | waterproof covering | wing-like structure |
| (3) | splits open when ripe | fibrous husk | fleshy and edible |
| (4) | fibrous husk | fleshy and edible | wing-like structure |

- 9 The diagram below shows three cells, P, Q and R.



Cell P

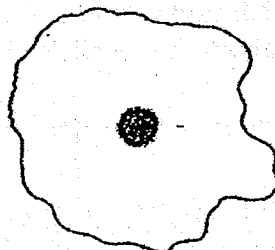

Cell Q

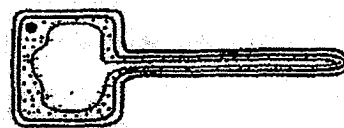

Cell R

Which one of the following statements is true?

- (1) Cell Q and Cell R are animal cells.
 - (2) Cell P and Cell R have no fixed shapes.
 - (3) Cell P and Cell R can make food for the plant.
 - (4) Cell P, Cell Q and Cell R can control the substances that enter or leave them.
- 10 The diagrams below show how gases are transported in the circulatory systems of a fish and a man.

Circulatory system of a fish

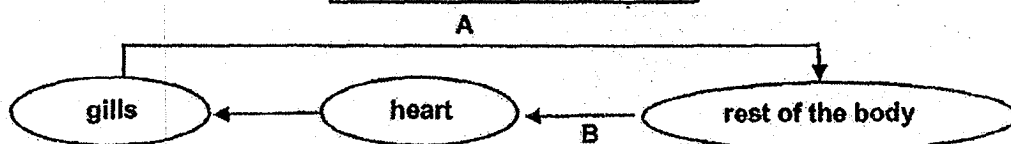

Circulatory system of a man

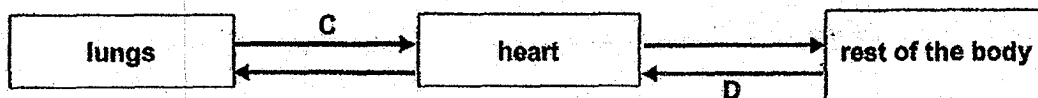

Which of the following correctly describe the blood vessels A, B, C and D?

| | Blood rich in oxygen | Blood rich in carbon dioxide |
|-----|----------------------|------------------------------|
| (1) | A and C | B and D |
| (2) | A and B | C and D |
| (3) | B and D | A and C |
| (4) | B and C | A and D |

- 11 Kaylie conducted an experiment in the laboratory. She filled four identical test tubes, W, X, Y and Z with the same volume of water at different temperatures. Then she covered the test tubes with identical stoppers.

The diagram below shows Kaylie's observation after five minutes.

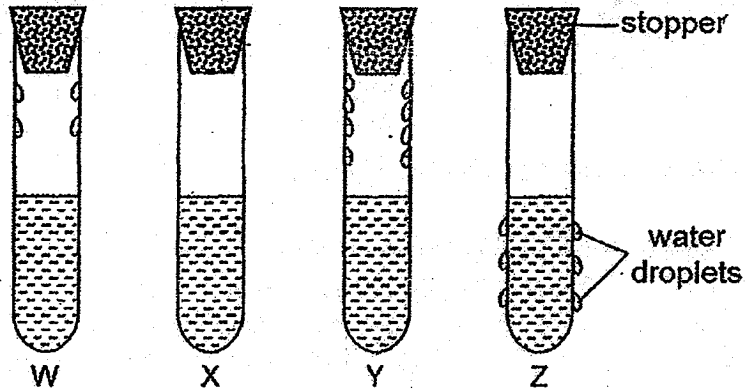

Which one of the following shows how the temperature of water arranged from the highest to the lowest?

Highest → Lowest

- (1) X, W, Y, Z
 (2) Y, W, X, Z
 (3) Y, Z, W, X
 (4) Z, X, W, Y
- 12 Study the four circuits in which identical bulbs and batteries are connected as shown below.

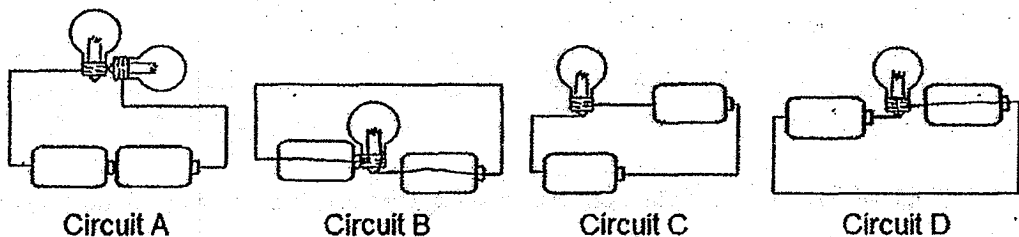

In which circuits would the bulb(s) light up?

- (1) A and B
 (2) A and C
 (3) B and D
 (4) C and D

- 13 Four bulbs, B1, B2, B3 and B4, were connected in a circuit with two switches, S1 and S2. All the components were working properly.

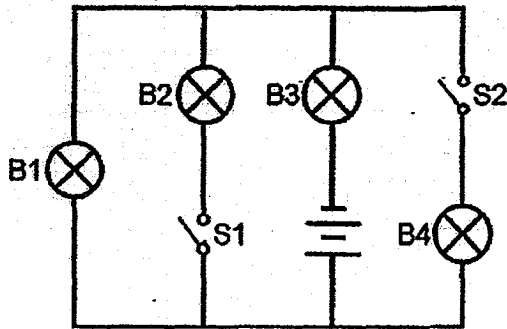

Which of the following is correct?

| | Switches | | Did the bulb light up? | | | |
|-----|----------|--------|------------------------|-----|-----|-----|
| | S1 | S2 | B1 | B2 | B3 | B4 |
| (1) | closed | closed | yes | no | yes | yes |
| (2) | closed | open | no | yes | yes | no |
| (3) | open | closed | no | no | yes | yes |
| (4) | open | open | yes | no | yes | no |

- 14 A restaurant uses a portable food warmer to keep food hot. The warmer has two identical bulbs which give out more heat when they are brighter.

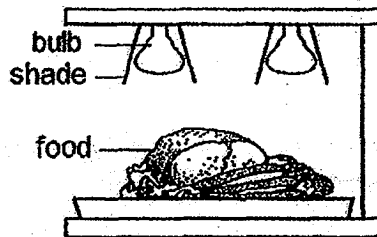

Which of the following circuits should be used such that food will be kept the warmest?

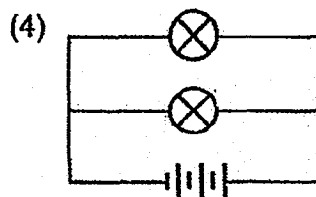
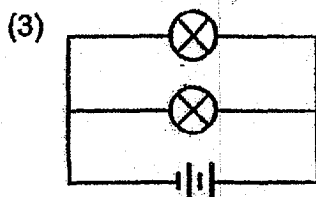
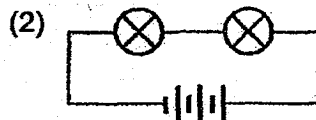
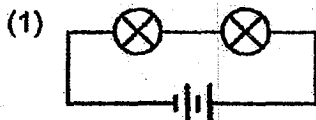

- 15 A block of butter was placed in each of the four boxes, A, B, C and D. The boxes are identical in size and made up of different materials of equal thickness.

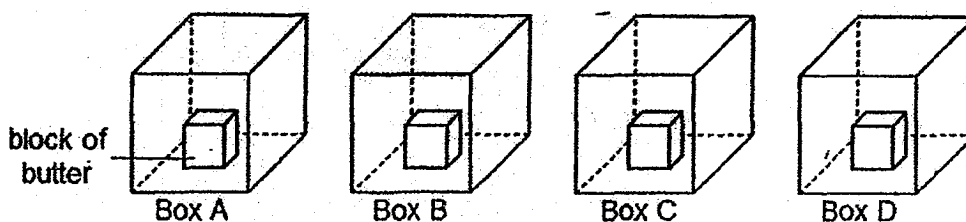

The graph below shows the time taken for the block of butter in each box to melt completely.

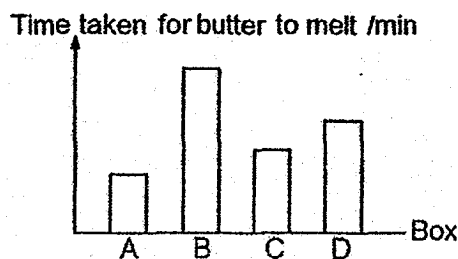

Based on the results, which box is the most suitable for keeping the butter?

- (1) A
 (2) B
 (3) C
 (4) D
- 16 Clarice heated a beaker of pure water and measured its temperature. The table below shows the results of the experiment.

| Time / min | Temperature / °C |
|------------|------------------|
| 0 | 30 |
| 2 | 50 |
| 4 | 70 |
| 6 | 90 |
| 8 | ? |

What is the temperature of the beaker of water at the 8th minute?

- (1) 90 °C
 (2) 100 °C
 (3) 110 °C
 (4) 120 °C

- 17 Siti was walking along a path, from A to E, with two lamps, L1 and L2, placed at position B and E respectively.

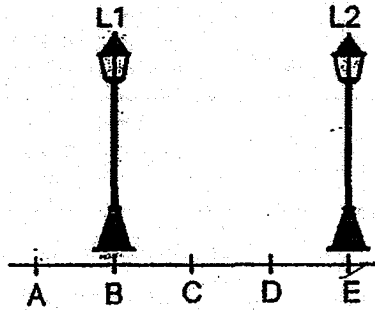

Which one of the following graphs shows how the length of her shadows changed?

Legend:
 — Shadow caused by L1
 - - - Shadow caused by L2

(1) Length of shadow

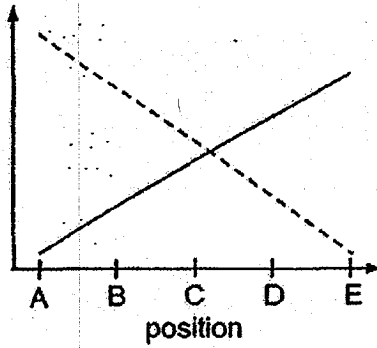

(2) Length of shadow

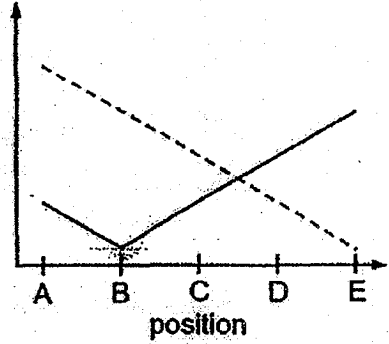

(3) Length of shadow

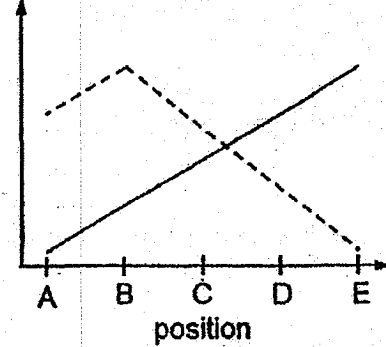

(4) Length of shadow

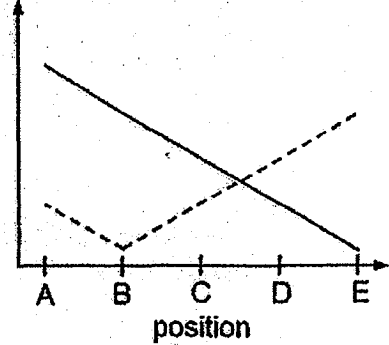

- 18 Study the classification chart below.

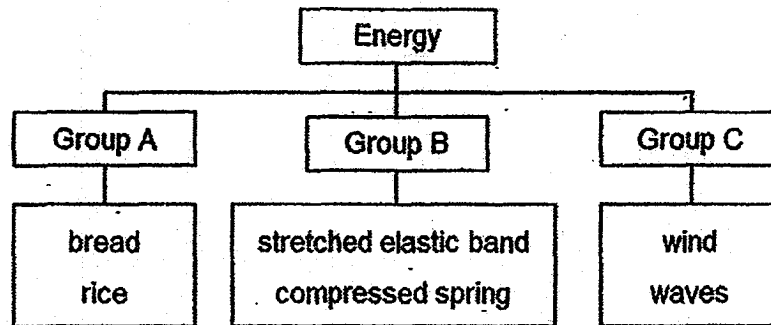

Which of the following are suitable headings for groups A, B and C?

| | A | B | C |
|-----|---------------------------|---------------------------|---------------------------|
| (1) | heat energy | kinetic energy | chemical potential energy |
| (2) | chemical potential energy | heat energy | sound energy |
| (3) | sound energy | chemical potential energy | heat energy |
| (4) | chemical potential energy | elastic potential energy | kinetic energy |

- 19 The diagram below shows a solar powered torch. The solar panel traps energy from the sun and stores it in the cell.

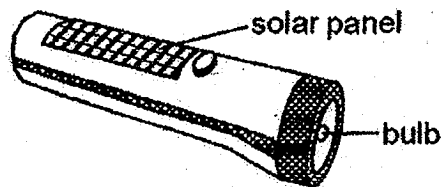

Which one of the following correctly shows the energy conversion when the torch is switched on?

- (1) Solar energy \rightarrow light energy \rightarrow heat energy
- (2) Solar energy \rightarrow electrical energy \rightarrow light energy + heat energy
- (3) Potential energy \rightarrow electrical energy \rightarrow light energy + heat energy
- (4) Potential energy \rightarrow solar energy \rightarrow light energy \rightarrow heat energy

- 20 Five bell jars, each containing a similar plant with the same number of leaves, were set up according to different set of conditions as shown in the table below.

| Condition | Set-up | | | | |
|----------------------------|--------|-----|-----|-----|-----|
| | 1 | 2 | 3 | 4 | 5 |
| 100 ml of water | No | No | Yes | Yes | Yes |
| Presence of sunlight | No | Yes | No | No | Yes |
| Presence of oxygen | Yes | Yes | Yes | No | Yes |
| Presence of carbon dioxide | No | No | Yes | Yes | Yes |

Which pair of set-ups is the most appropriate to show that sunlight is needed for photosynthesis?

- (1) Set-ups 1 and 2
 (2) Set-ups 1 and 5
 (3) Set-ups 3 and 4
 (4) Set-ups 3 and 5
- 21 Ali used a spring balance to pull four blocks, A, B, C and D, along four similar surfaces in his experiment below. The blocks are of similar sizes and made of same material.

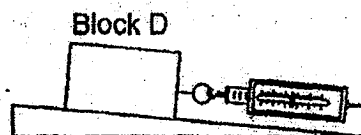
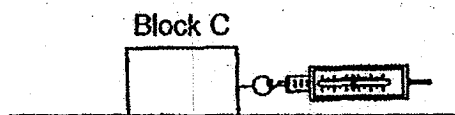
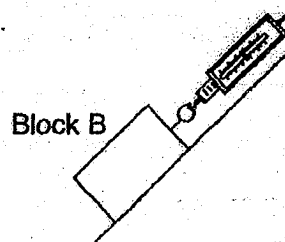
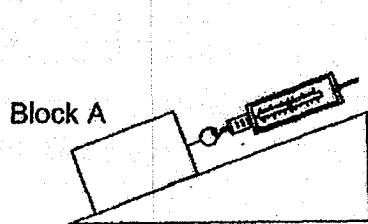

If the spring balance shows the same readings for all the blocks, which block has the smallest mass?

- (1) Block A
 (2) Block B
 (3) Block C
 (4) Block D

22 Study the four set-ups below.

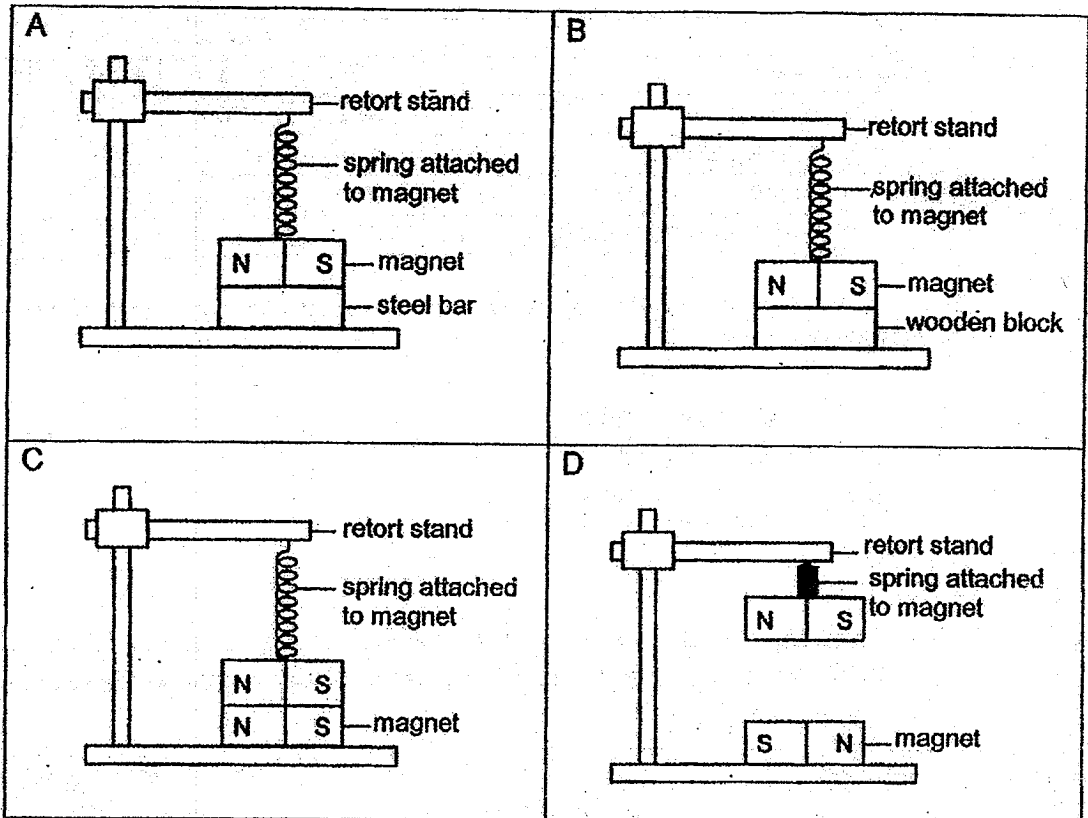

Which of the above arrangement(s) of the magnets is/are possible?

- (1) A only
- (2) A and B only
- (3) C and D only
- (4) A, B, C and D

23 Joshua threw a basketball at X and it moved along the path as shown in the diagram below.

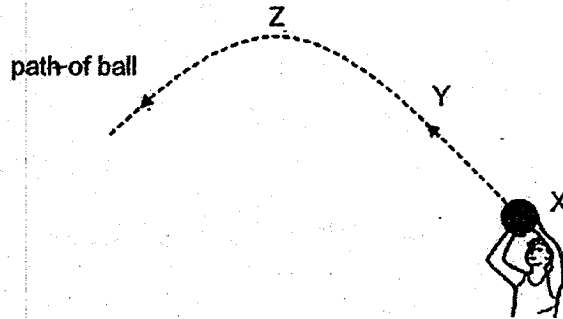

Which statements are not true?

- A At X, there is no force acting on the basketball.
- B At Y, there is gravitational attraction between the basketball and the Earth.
- C At Z, the basketball started to fall as there was no more force acting on it.
- D The gravitational force acting on the basketball does not change from point X to Z.

- (1) A and C only
- (2) B and D only
- (3) A, B and C only
- (4) A, B, C and D

24 The diagram below shows a pond habitat.

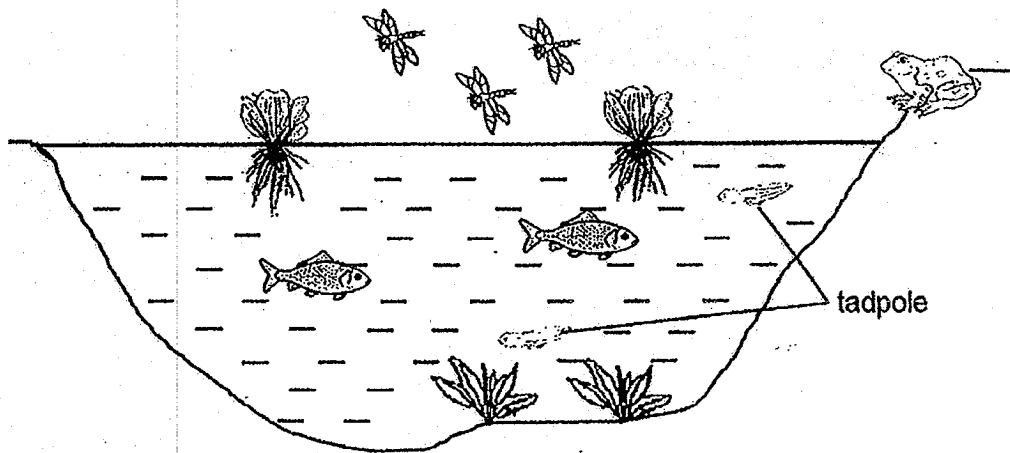

How many populations of producers and consumers are present in this habitat?

| | Number of populations of | |
|-----|--------------------------|-----------|
| | producers | consumers |
| (1) | 2 | 3 |
| (2) | 2 | 4 |
| (3) | 4 | 3 |
| (4) | 4 | 8 |

25 Study the food web as shown below.

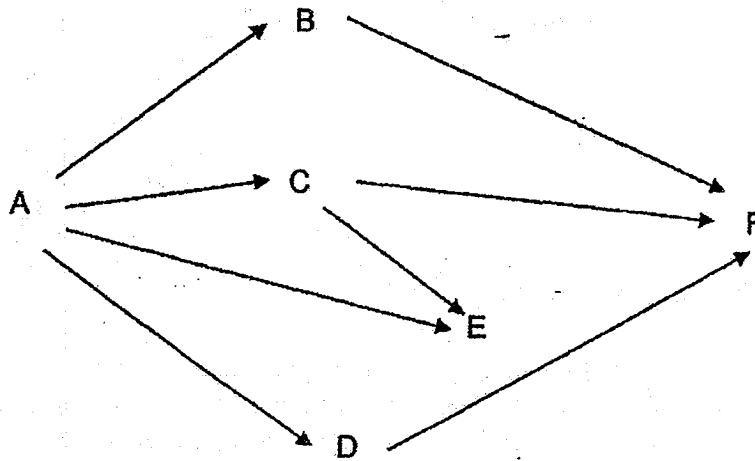

Which of the following statements about the food web are true?

- A Organism D and F are both preys and predators.
- B There are three plant-eaters and one animal-eater.
- C Organism E gets its energy directly from organisms A and C.
- D All the energy in organism B is transferred to organism F.

- (1) A and D only
- (2) B and C only
- (3) A, B and C only
- (4) B, C and D only

26 Study the food web shown below.

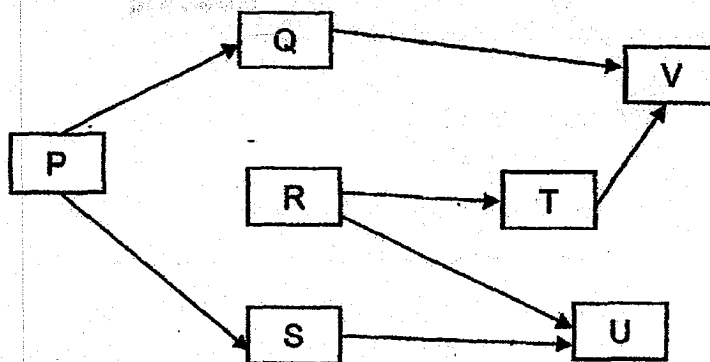

If the population of organism R decreases, which of the following populations will be most affected?

- (1) Q
- (2) S
- (3) T
- (4) U

27 A praying mantis has several adaptations which help to protect it from predators.



What are some of these structural adaptations?

- A It spreads its forelegs to appear bigger.
 - B It has feelers which help it to detect danger.
 - C It fans its wings to appear more threatening.
 - D It blends in with the surroundings to hide from its predators.
- (1) B and D only
 - (2) A, B and D only
 - (3) A, C and D only
 - (4) A, B, C and D

- 28 The graph below shows how the amount of carbon dioxide in the air has changed over the years in a country from 1970 to 2010.

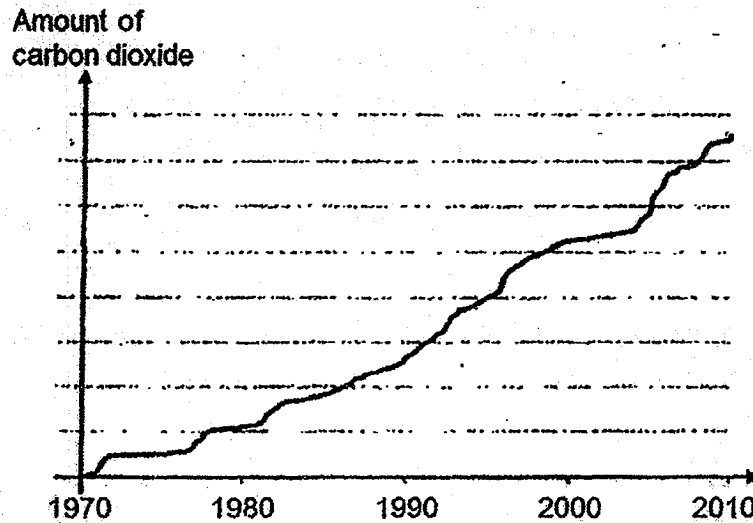

Which of the following is/are effect(s) of the trend shown in the graph above?

- A flood
 - B acid rain
 - C soil erosion
 - D deforestation
- (1) A only
(2) A and B only
(3) B, C and D only
(4) A, C and D only

End of Booklet A

METHODIST GIRLS' SCHOOL
Founded in 1887



PRELIMINARY EXAMINATION 2019
PRIMARY 6
SCIENCE

BOOKLET B1

Total Time for Booklets A and B: 1 hour 45 minutes

INSTRUCTIONS TO CANDIDATES

Do not turn over this page until you are told to do so.
Follow all instructions carefully.
Answer all questions.
Write your answers in this booklet.

Name: _____ ()

Class: Primary 6. _____

Date : 22 August 2019

| | |
|---------------------------|-----|
| Booklet A | 56 |
| Booklet B1 | 22 |
| Booklet B2 | 22 |
| Total | 100 |
| Parent's Signature | |

This booklet consists of 9 printed pages including this page.

For questions 29 to 34, write your answers in the spaces provided. The number of marks available is shown in brackets [] at the end of each question or part question. [22 marks]

29 Study the animals as shown below.

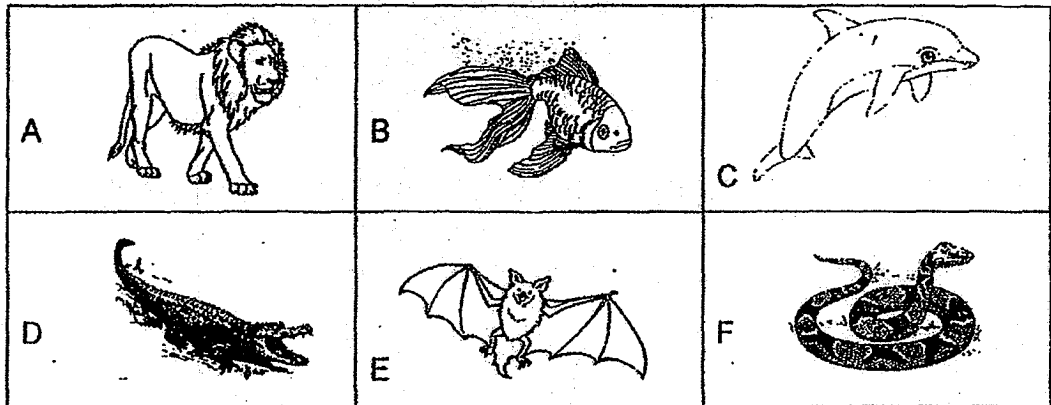

(a) Animals A and B have been grouped under Group X and Group Y respectively as shown below. Classify animals C to F in the chart below respectively. [2]

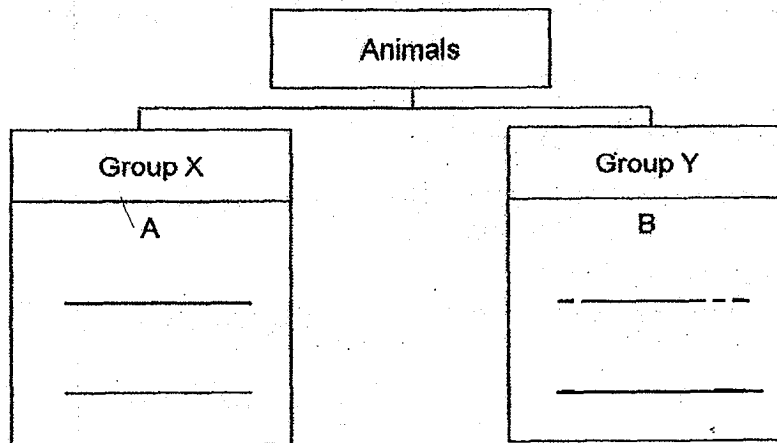

(b) Suggest suitable headings based on your answer in (a) [1]

Group X: _____

Group Y: _____

| | |
|-------|---|
| SCORE | 3 |
|-------|---|

(Go on to the next page)

- 30 The table below shows some characteristics of flowers from two plants, F and G.

| Plant F | Plant G |
|--------------------------------|----------------------------|
| Large brightly coloured petals | Small dull coloured petals |
| Long stigma | Short stigma |
| One ovule in ovary | Many ovules in ovary |

The diagram below shows a fruit formed from one of the plants. It is cut into half as shown below.



- (a) How are the flowers of Plant F pollinated? Give a reason for your answer. [1]

- (b) Which plant, F or G, is the fruit most likely taken from? Explain your answer. [1]

The diagram below shows a seed germinating into a seedling after it was dispersed.

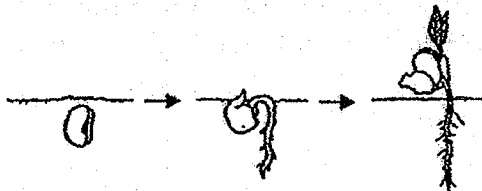

- (c) What are the conditions necessary for it to take place? [1]

A farmer conducted an experiment using plant F. He removed an outer ring of the stem at position M as shown in the diagram below. The food-carrying tubes were removed while the water carrying tubes remained in the stem.

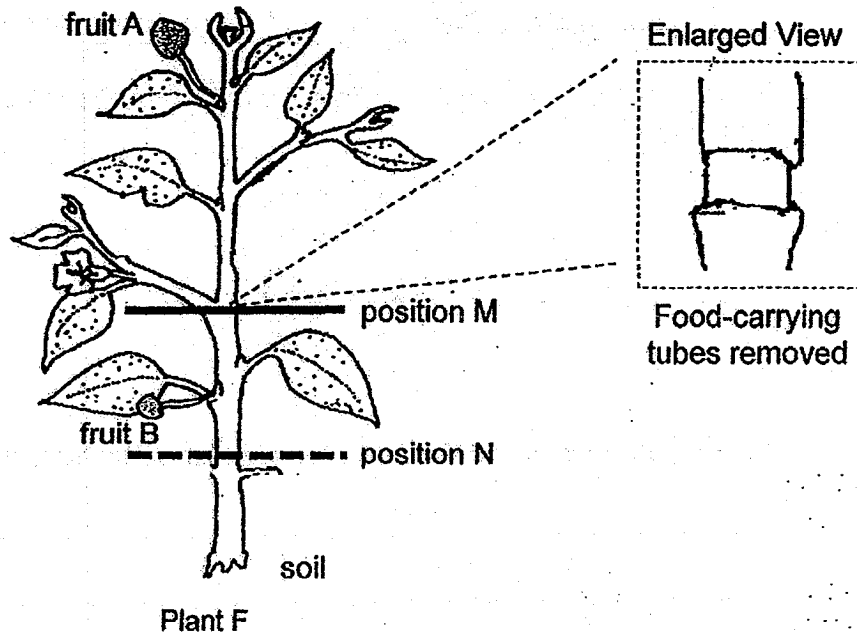

- (d) The farmer observed that after two weeks, fruit A grew bigger than fruit B. Suggest why fruit A was bigger. [1]

- (e) The farmer then made a deeper cut at position N and removed the water-carrying tubes. He observed that the plant wilted after some time. Suggest a possible reason. [1]

| | |
|-------|---|
| SCORE | 5 |
| | 5 |

31 The diagram below shows a life process occurring in a female body.

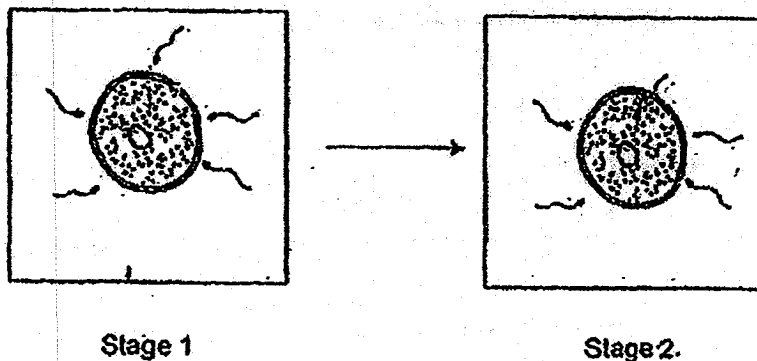

(a) Describe what happens during the process. [1]

The flow of substances between different body systems in a human being can be represented by the diagram below.

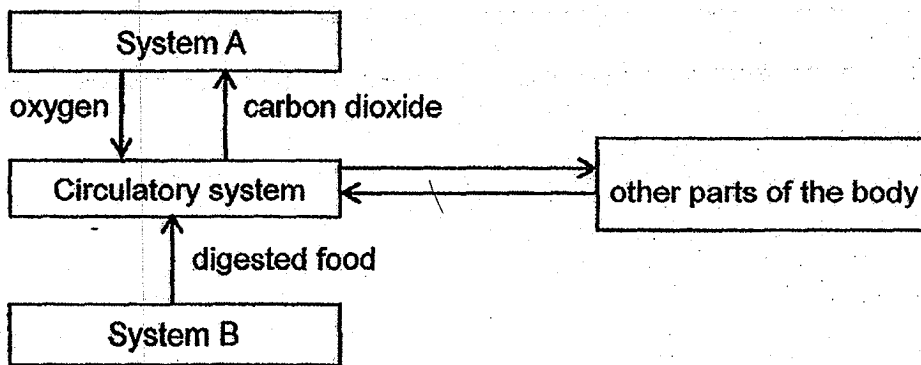

(b) What are systems A and B? [1]

System A: _____ system

System B: _____ system

| | |
|-------|---|
| SCORE | 2 |
|-------|---|

(Go on to the next page)

The graph below shows the volume of blood passing through the small intestine during rest and exercise over a period of time.

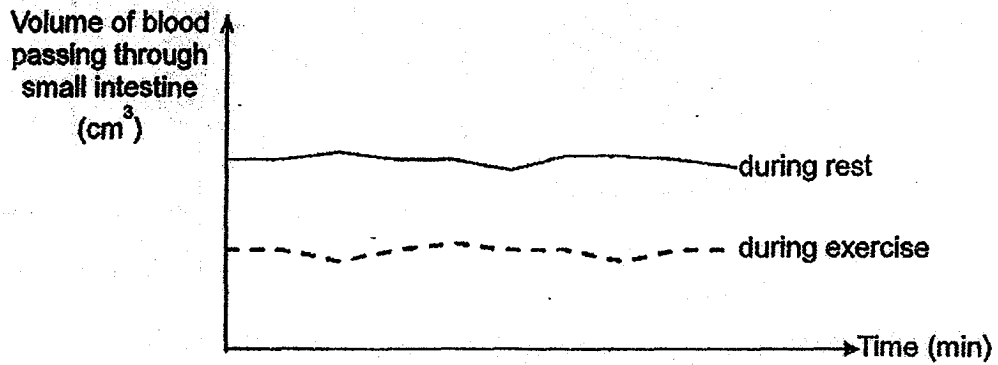

- (c) Using the graph above, explain how exercising after a meal affects the absorption of digested food in the small intestine. [2]

| | |
|-------|---|
| SCORE | 2 |
|-------|---|

(Go on to the next page)

- 32 Muthu wanted to find out how light affects the number of bubbles produced by a water plant. He placed a lamp at different distances from set-up and counted the number of bubbles produced per minute.

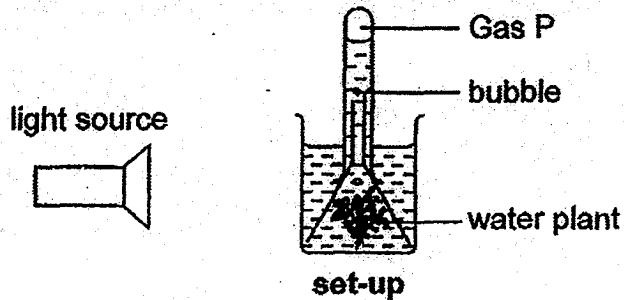

His results are shown below.

| | | | | | |
|-----------------------------------|----|----|----|----|----|
| Distance of lamp from set-up (cm) | 25 | 20 | 15 | 10 | 5 |
| Number of bubbles per minute | 10 | 15 | 20 | 25 | 25 |

- (a) Based on Muthu's results, what is the relationship between the distance of lamp from the water plant and the rate of photosynthesis? Explain your answer. [2]

- (b) Name Gas P. How was it produced? [1]

- (c) Muthu prepared another set-up as above without the light source. Explain the purpose of the set-up. [1]

| | |
|-------|---|
| SCORE | |
| | 4 |

(Go on to the next page)

- 33 Lily conducted an experiment with two trays containing the same amount of soil as shown below. A patch of grass was placed in Tray B but not Tray A. She left each tray at equal distance in front of a fan. After two hours, she recorded the amount of soil particles collected on the paper under each tray.

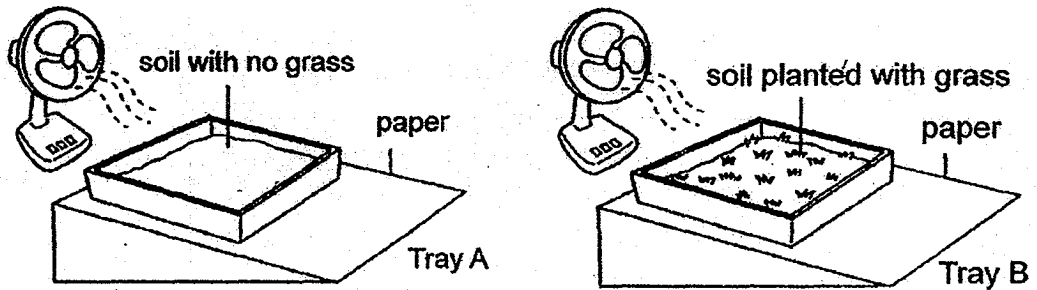

After the experiment, she concluded that there was more soil particles collected on the paper under Tray A than Tray B.

- (a) Give a reason why there was more soil particles collected on the paper under Tray A than Tray B. [1]

The diagram below shows a road winding around a highland in a country.

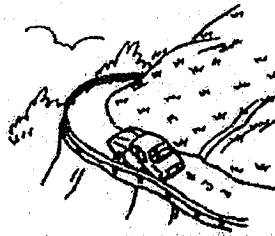

- (b) Based on the experiment in (a), explain clearly how growing plants on the slope can prevent soil erosion. [1]

- (c) Suggest another negative impact if all the plants on the slope of the highland are cut down. [1]

| | |
|-------|---|
| SCORE | |
| | 3 |

- 34 Animal J is a small animal with hard shell and it can be found on rocks. Some of them attach themselves to the skin of Animal K and form thick crusts on its head, tail and flippers as shown below.

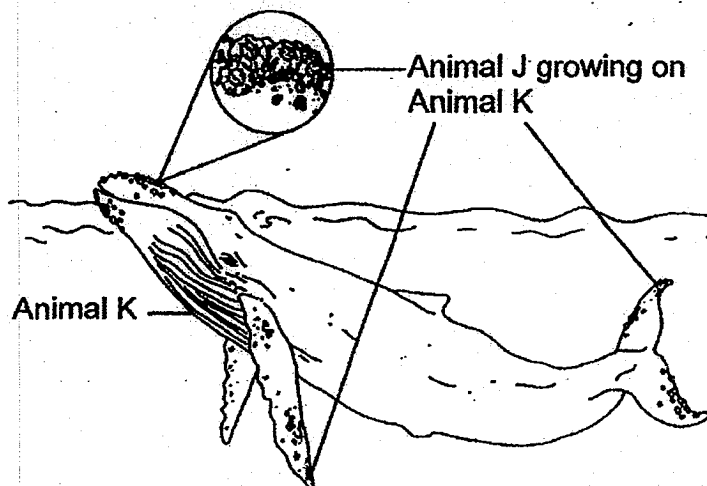

- (a) Animal J attach themselves on Animal K and get carried to other places. How does being carried to other places benefit Animal J? [1]

- (b) Animal K sometimes defends itself by striking its head, flippers or tail at its predators. How is the presence of Animal J an advantage to Animal K? [1]

- (c) Explain how the body shape of Animal K can help in its survival. [1]

| | |
|-------|---|
| SCORE | 3 |
|-------|---|

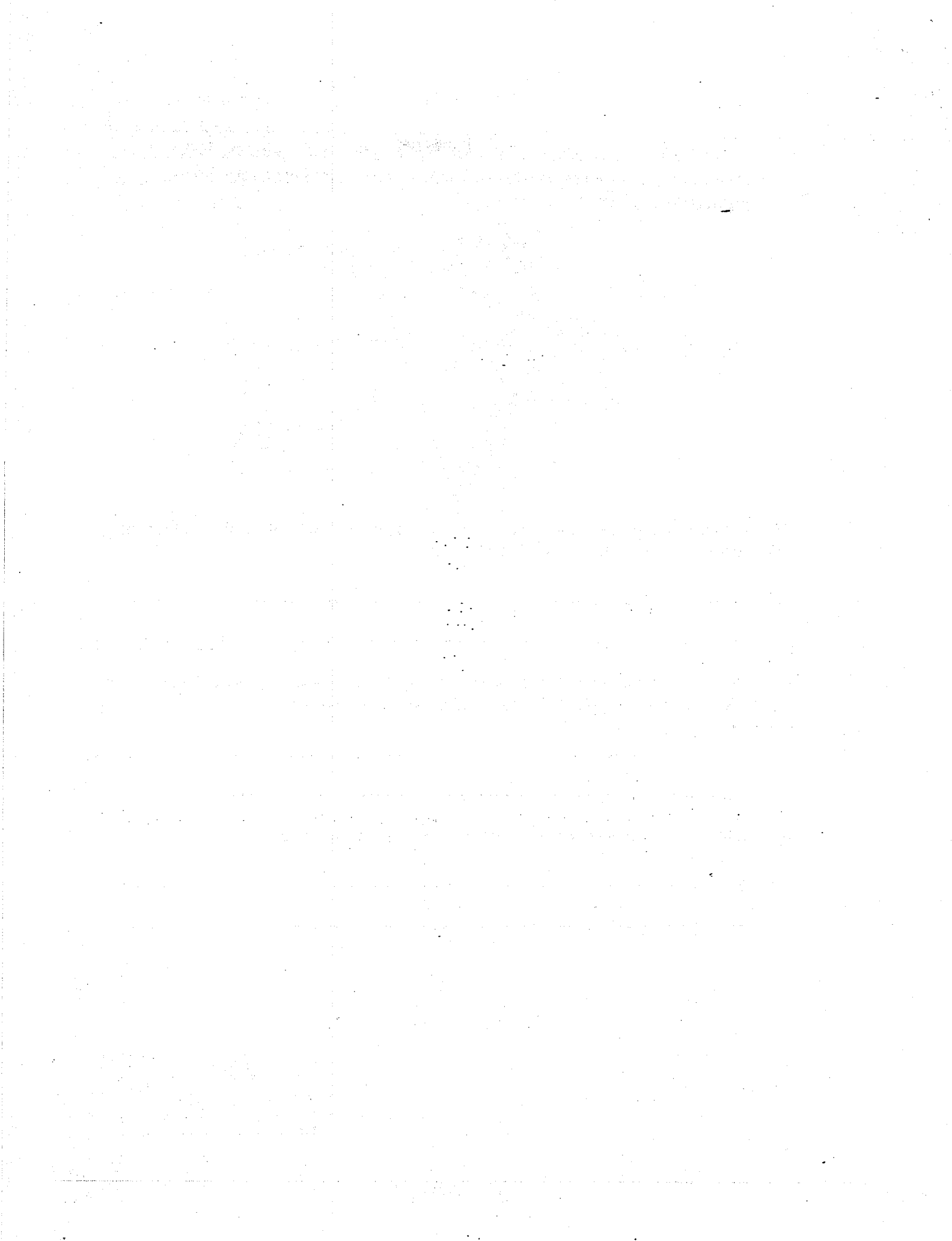

METHODIST GIRLS' SCHOOL

Founded in 1887



**PRELIMINARY EXAMINATION 2019
PRIMARY 6
SCIENCE**

BOOKLET B2

Total Time for Booklets A and B: 1 hour 45 minutes

INSTRUCTIONS TO CANDIDATES

Do not turn over this page until you are told to do so.
Follow all instructions carefully.
Answer all questions.

Name: _____ ()

Class: Primary 6. _____

Date : 22 August 2019

| | |
|------------|----|
| Booklet B2 | 22 |
|------------|----|

For questions 35 to 40, write your answers in the spaces provided. The number of marks available is shown in brackets [] at the end of each question or part question. [22 marks]

- 35 Morgan wanted to frame some photos and hang them onto the wall for display. Each frame has a mass of 150g and he had to attach a string to it so that he could hang it.

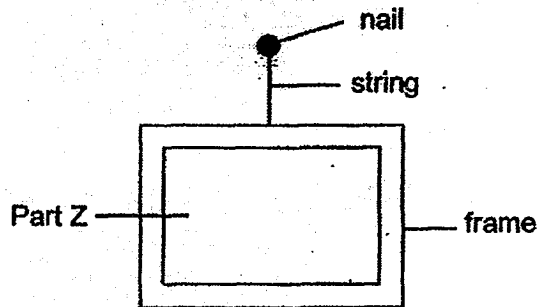

To find suitable strings for his frames, Morgan carried out an experiment. He kept adding loads onto each string, A, B, C and D, until it broke. The strings were of equal length but made of different materials.

His results are as shown in the table below.

| String | Amount of loads hung onto string before it broke (g) |
|--------|--|
| A | 130 |
| B | 190 |
| C | 80 |
| D | 220 |

- (a) Which strings should Morgan chose to hang his picture frames? Give a reason for your answer. [1]

- (b) What property of material is suitable for making part Z of the photo frame? Give a reason for your answer. [1]

| | |
|-------|---|
| SCORE | 2 |
|-------|---|

(Go on to the next page)

- 36 Mei Li set up an experiment with two setups, P and Q, as shown.

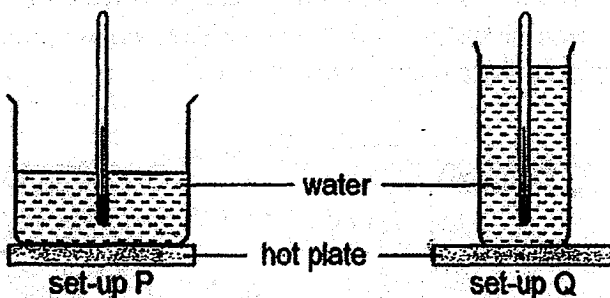

Two beakers of different sizes, filled with equal amount of water at room temperature, were heated on identical hot plates for two minutes.

- (a) In which setup, P or Q, would the thermometer record a higher reading? Explain your answer. [1]

- (b) Mei Li observed that there was less water left in set-up P at the end of the experiment. Explain the observation. [1]

Mei Li watched a documentary film featuring animal H which lived in a hot desert with temperature of up to 60°C . It lifted up its front leg and opposite hind leg on an alternate basis.



- (c) How does this adaptation help animal H to keep itself cool in the hot desert? [1]

Mei Li filled two identical cooler boxes, J and K, with the same number of bottled drinks and same mass of ice cubes as shown below. Then she filled cooler box K with tap water but left cooler box J as it was.

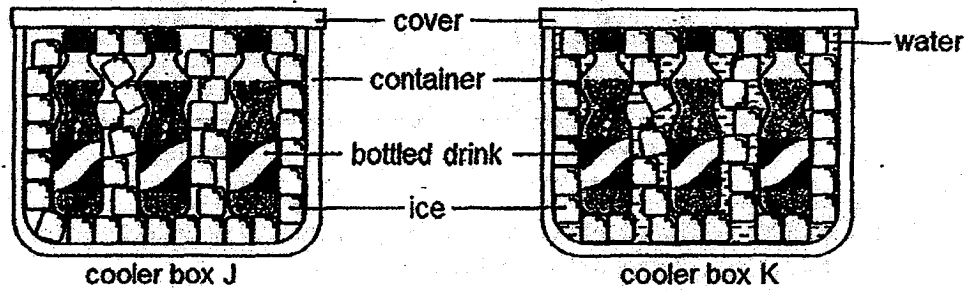

- (d) Mei Li found that the bottled drinks in cooler box K were colder than those in cooler box J. Explain the observation. [1]

| | |
|-------|---|
| SCORE | 4 |
|-------|---|

- 37 The diagram below shows the heater of a car and its circuit diagram. When the heater is switched on, it helps to clear mist formed on the rear window and prevent mist from forming.

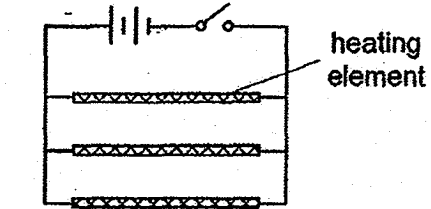
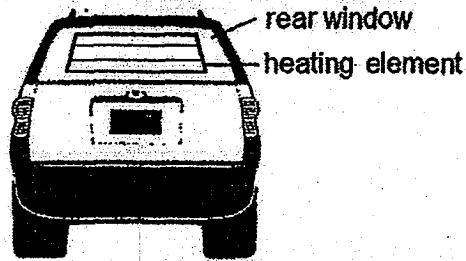

Circuit diagram of heater

- (a) Are the heating elements arranged in series or parallel? What is the advantage of this arrangement? [1]

- (b) Explain how the heater prevents forming of mist on the rear window when it is switched on. [1]

- (c) Fill in the boxes below to show the energy conversion when the switch is closed. [1]

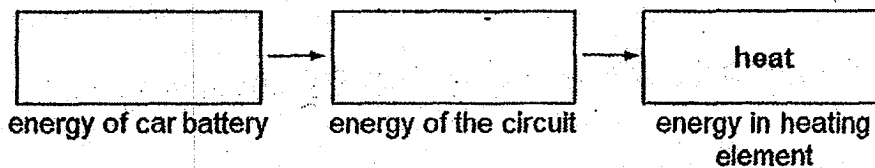

| | |
|-------|---|
| SCORE | 3 |
|-------|---|

- 38 Jim set up an experiment as shown below. He hung three balls of the same mass, X, Y and Z, from the same type of strings from a pole above a tray of sand.

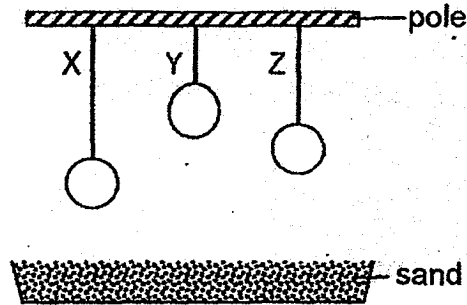

Tim cut the strings and measured the depth of depression, d , made by each ball in the sand.



The results were as shown in the table below.

| Ball | Depth of depression, d (cm) | | |
|------|-------------------------------|----------------|---------------|
| | First reading | Second reading | Third reading |
| | 3.2 | 3.5 | 3.3 |
| | 4.9 | 5.1 | 5.0 |
| | 0.9 | 1.1 | 1.2 |

- (a) Fill in the table above to show the results for balls X and Z. [1]
- (b) Why did ball Y make the deepest depression? Explain your answer in (a) in terms of energy conversion. [2]

- (c) Why were balls of the same mass used in the experiment? [1]

Jim saw two flower pots, A and B, hanging from the ceiling at the common corridor outside his neighbour's house.

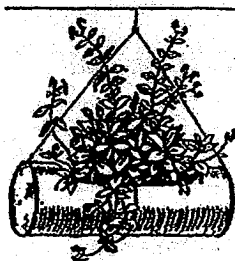

flower pot A
1 kg

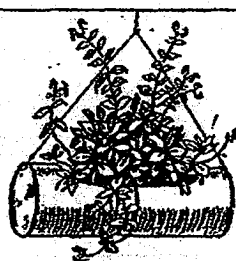

flower pot B
3 kg

- (d) Which flower pot, A or B, would drop to the ground with a greater impact? Explain your answer. [1]

| | |
|-------|---|
| SCORE | / |
| | 5 |

(Go on to the next page)

- 39 Mr Tan used the set-up below to show how a carpark barrier works.

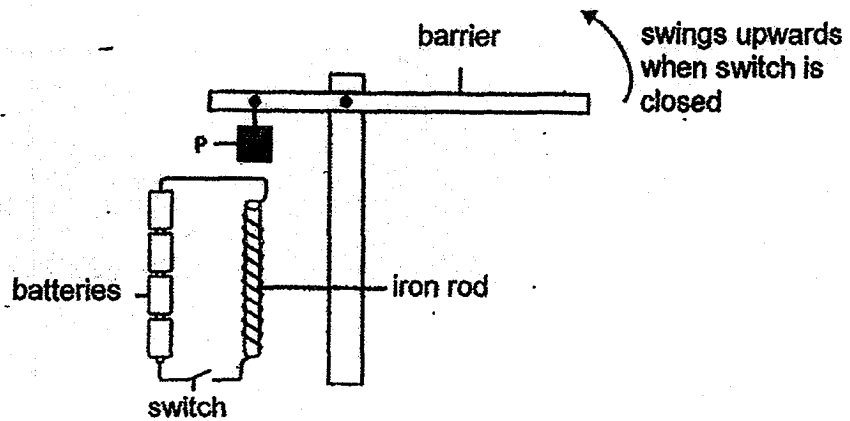

The carpark barrier remains in a balanced position when the switch is open as shown above. However, the barrier will swing upwards when the switch is closed.

- (a) Explain why the carpark barrier swings upwards after the switch is closed. [2]

- (b) What happens if the Iron rod is replaced by a copper rod? Explain your answer. [1]

- (c) Suggest one change to the set-up to decrease the speed of the carpark barrier. [1]

| | |
|-------|---|
| SCORE | 4 |
|-------|---|

- 40 Jerry conducted an experiment using the two containers as shown below.

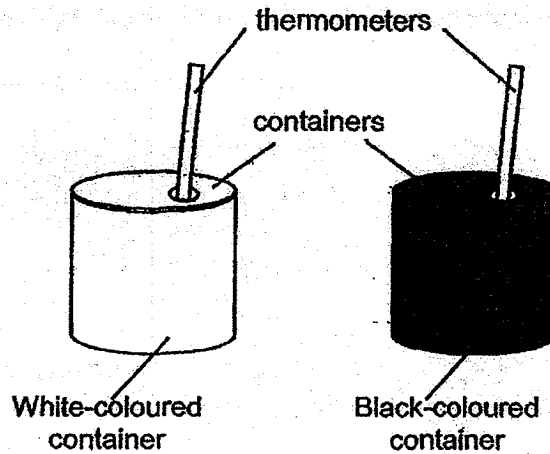

He painted the two containers with different colours and placed them under the sun. He recorded the temperature of the air inside each container at the start and after five hours in the table below.

| Colour of container | White | Black |
|--|-------|-------|
| Initial Temperature ($^{\circ}\text{C}$) | 28 | 28 |
| Final Temperature ($^{\circ}\text{C}$) | 35 | 40 |

- (a) Based on Jerry's table, explain how the colour of the container affects the final temperature of the air in it. [1]

- (b) Based on the results in (a), explain why having black back is an advantage for Animal P. [1]

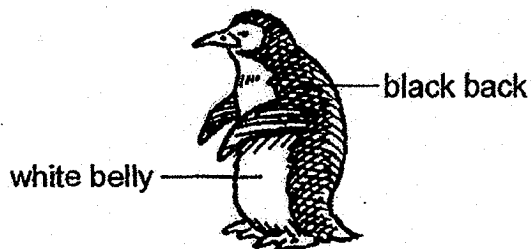

Air pollution has caused some black carbon to be deposited on ice. This has resulted in the ice turning black in the Polar Regions as shown in the diagram below.

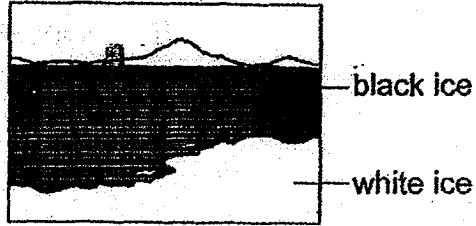

(c) Based on the above results and information, explain how this would reduce the population size of Animal P staying in the Polar Regions. [2]

| | |
|-------|---|
| SCORE | 4 |
|-------|---|

SCHOOL : MGS PRIMARY SCHOOL
LEVEL : PRIMARY 6
SUBJECT : SCIENCE
TERM : 2019 PERLIM

SECTION A

| | | | | | | | | | |
|-------------|------------|------------|------------|------------|------------|------------|------------|------------|------------|
| Q 1 | Q2 | Q3 | Q4 | Q5 | Q6 | Q7 | Q8 | Q9 | Q10 |
| 2 | 3 | 2 | 1 | 3 | 4 | 4 | 3 | 4 | 1 |
| Q 11 | Q12 | Q13 | Q14 | Q15 | Q16 | Q17 | Q18 | Q19 | Q20 |
| 2 | 3 | 4 | 4 | 2 | 2 | 2 | 4 | 3 | 4 |
| Q 21 | Q22 | Q23 | Q24 | Q25 | Q26 | Q27 | Q28 | | |
| 2 | 2 | 1 | 1 | 2 | 3 | 1 | 1 | | |

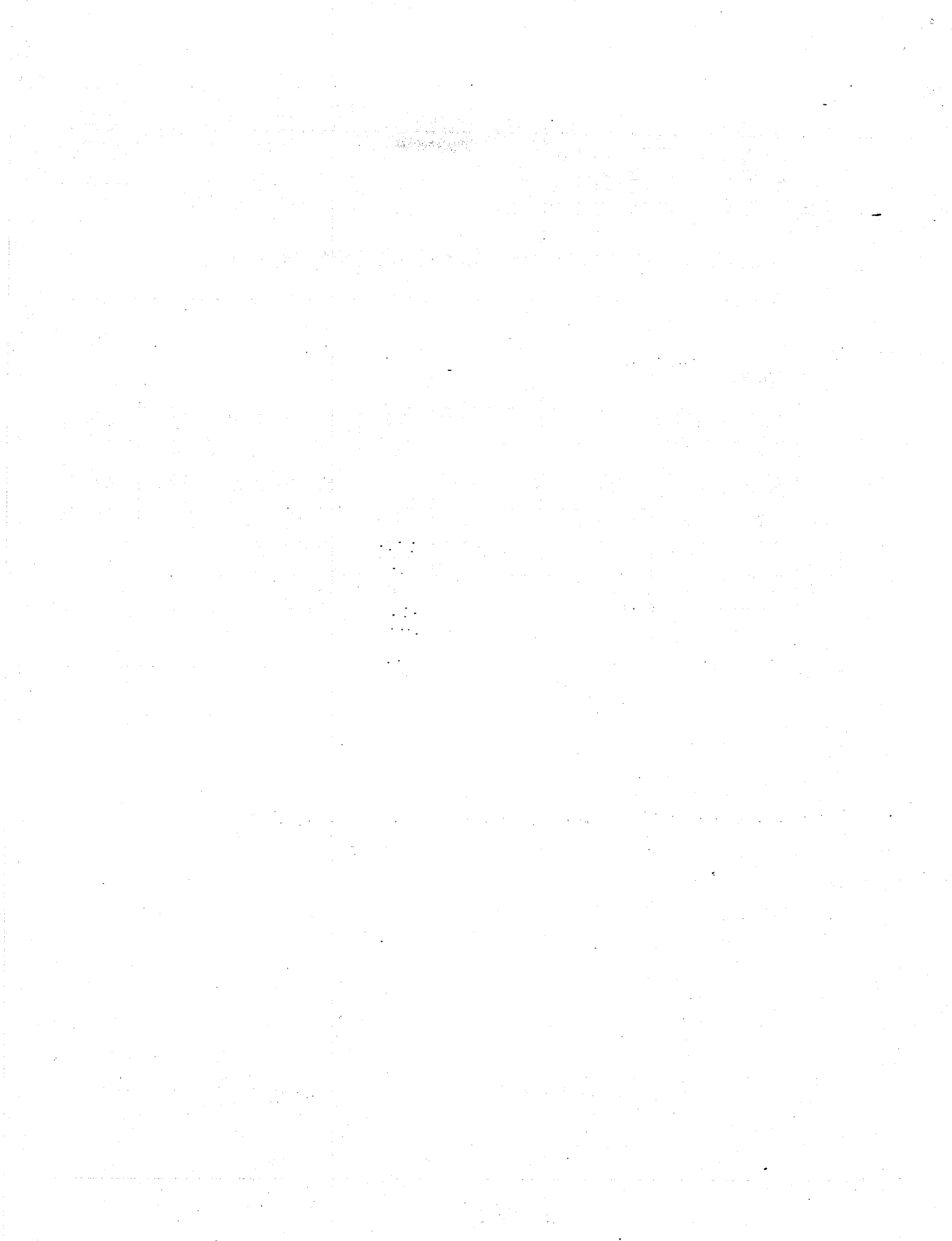

Methodist Girls' School (Primary)
P6 Preliminary Examination 2019 Answer Key (For Students)
Section B1 & B2

| Qn. | Acceptable Answers |
|-----|---|
| 29a | Group X: A, C, E Group Y: B, D, F |
| 29b | Group X: Have hair/ Reproduce by giving birth Group Y: Have scales/ Reproduce by laying eggs |
| 30a | By animals because Plant F has large brightly-coloured petals that attract insects/ birds/ pollinators. |
| 30b | Plant G, the fruit has many seeds which are developed from the ovules of its flower. |
| 30c | Germination requires air/ oxygen, water/ moisture and warmth. |
| 30d | More food was made by more leaves above position M and it was transported to fruit A. |
| 30e | The farmer remove the water- carrying tubes so the water absorbed by the roots could not be transported to the leaves for making food/ life processes/ survival. |
| 31a | Fertilization occurs when the sperm and egg fuse together. |
| 31b | System A: Respiratory System B: Digestive |
| 31c | During exercise, more blood is pumped to other parts of the body, less blood passes through the small intestine so less digested food can be absorbed by the blood (which slows down the rate of digestion). |
| 32a | The greater/ shorter the distance of lamp from the water plant, the lower/ higher the rate of photosynthesis. |
| 32b | Oxygen. The water plant produced oxygen when it trapped light energy to make food during photosynthesis. |
| 32c | It acts as a control set-up to prove/ compare & confirm that the results/ number of bubbles produced is due to the presence of light source. |
| 33a | There were no roots of the grass to hold the soil together in Tray A so soil was being blown away more easily as compared to Tray B. |
| 33b | The roots of the plants will hold the soil particles together, preventing soil erosion/landslide. |
| 33c | Global warming/ Loss of habitat for plants/ animals/ Water pollution. |
| 34a | Animal J can find more food / find food more easily as Animal K moves to different places/ protection/hide/escape from predators |
| 34b | The thick crusts formed by Animal J serves as an armour/ weapon to help Animal K injure its predators/ other animals. |
| 34c | The body shape of Animal K helps it to swim quickly in/through water to hunt for its prey/ to escape from its predators. |
| 35a | Strings B and D. Each can support a load of more than 150g before they break/ tear. |
| 35b | The material for making part Z must allow all/ most light to pass through/ transparent so that the photo can be seen. |
| 36a | Set-up P. There was more surface in contact with the hot plate so water in set-up P gained heat faster than in set-up Q. |
| 36b | The water in set-up P has a bigger exposed surface area, the higher rate of evaporation caused more water to evaporate and less water left. |
| 36c | Less surface area of Animal H's legs were in contact with the hot sand so Animal H gained less heat. |
| 36d | Water is a better conductor of heat than air and it lost heat faster to ice. The bottled drinks in cooler box K lost heat faster to cooled water/ water and ice and thus had lower temperature. |
| 37a | Parallel. If one of the heating elements is faulty, the heater/other heating elements can still work. |
| 37b | The heating element heats up the rear window to a temperature higher than the surrounding. Water vapour cannot condense on the rear window /The absence of cooler surface prevents condensation. So no mist will be formed. |

| 37d |  <p style="text-align: center;"> (chemical) potential → Electrical → heat energy of car battery energy of the circuit energy in heating element </p> | | | | | | | | | | | | | | | | | | | | |
|-----------------------------|--|-----------------------------|---------------|--|--|------|---------------|----------------|---------------|---|-----|-----|-----|---|-----|-----|-----|---|-----|-----|-----|
| 38a | <table border="1" style="margin-left: auto; margin-right: auto;"> <thead> <tr> <th colspan="4" style="text-align: center;">Depth of depression, d (cm)</th> </tr> <tr> <th style="text-align: center;">Ball</th> <th style="text-align: center;">First reading</th> <th style="text-align: center;">Second reading</th> <th style="text-align: center;">Third reading</th> </tr> </thead> <tbody> <tr> <td style="text-align: center;">Z</td> <td style="text-align: center;">3.2</td> <td style="text-align: center;">3.5</td> <td style="text-align: center;">3.3</td> </tr> <tr> <td style="text-align: center;">Y</td> <td style="text-align: center;">4.9</td> <td style="text-align: center;">5.1</td> <td style="text-align: center;">5.0</td> </tr> <tr> <td style="text-align: center;">X</td> <td style="text-align: center;">0.9</td> <td style="text-align: center;">1.1</td> <td style="text-align: center;">1.2</td> </tr> </tbody> </table> | Depth of depression, d (cm) | | | | Ball | First reading | Second reading | Third reading | Z | 3.2 | 3.5 | 3.3 | Y | 4.9 | 5.1 | 5.0 | X | 0.9 | 1.1 | 1.2 |
| Depth of depression, d (cm) | | | | | | | | | | | | | | | | | | | | | |
| Ball | First reading | Second reading | Third reading | | | | | | | | | | | | | | | | | | |
| Z | 3.2 | 3.5 | 3.3 | | | | | | | | | | | | | | | | | | |
| Y | 4.9 | 5.1 | 5.0 | | | | | | | | | | | | | | | | | | |
| X | 0.9 | 1.1 | 1.2 | | | | | | | | | | | | | | | | | | |
| 38b | <p>When Y was hung the highest above the sand, it possessed the most (gravitational) potential energy. When the string was cut, the potential energy was converted to kinetic energy as it was falling. Y had the most kinetic energy before it hit the sand and made the deepest depression.</p> | | | | | | | | | | | | | | | | | | | | |
| 38c | <p>To ensure the depth of depression was due to the height at which the ball was hung and not due to the mass of the ball.</p> | | | | | | | | | | | | | | | | | | | | |
| 38d | <p>Flower pot B. B has a greater mass than A so it possesses more (gravitational) potential energy.</p> | | | | | | | | | | | | | | | | | | | | |
| 39a | <p>When the switch is closed, electric current flows through the circuit, the iron rod becomes an electromagnet / becomes magnetised and attracted Object P downwards. This caused the barrier to swing upwards.</p> | | | | | | | | | | | | | | | | | | | | |
| 39b | <p>The copper rod cannot not be an electromagnet / magnetised as it is a non-magnetic material so the set-up will not work.</p> | | | | | | | | | | | | | | | | | | | | |
| 39c | <p>Reduce the number of turns of the coil around the rod. / Reduce the number of batteries.</p> | | | | | | | | | | | | | | | | | | | | |
| 40a | <p>The final temperature of the air inside the black container is higher/ greater the air inside the white container as black colour absorbs/ gains more heat than white colour.</p> | | | | | | | | | | | | | | | | | | | | |
| 40b | <p>The black back is able to absorb/ gain more heat from the Sun to keep Animal P warmer.</p> | | | | | | | | | | | | | | | | | | | | |
| 40c | <p>The black ice will gain more heat/ heat faster than the white ice and melt faster, causing the sea level to rise. This causes the loss of ice and breeding ground for Animal P to lay their eggs so the population of the penguins will decrease.</p> | | | | | | | | | | | | | | | | | | | | |