

NANYANG PRIMARY SCHOOL

PRIMARY 6 SCIENCE

**PRELIMINARY EXAM
2019**

BOOKLET A

Date : 23 August 2019

Duration : 1 h 45 min

Name : _____ ()

Class: Primary 6

**DO NOT OPEN THIS BOOKLET UNTIL YOU ARE TOLD TO DO SO.
FOLLOW ALL INSTRUCTIONS CAREFULLY.**

Booklet A consists of 21 printed pages including this cover page.

Section A

For each question from 1 to 28, four options are given. One of them is the correct answer. Indicate your choice in this booklet and shade the correct oval (1, 2, 3 or 4) on the Optical Answer Sheet provided.

1. The diagram below shows a rotting log habitat.

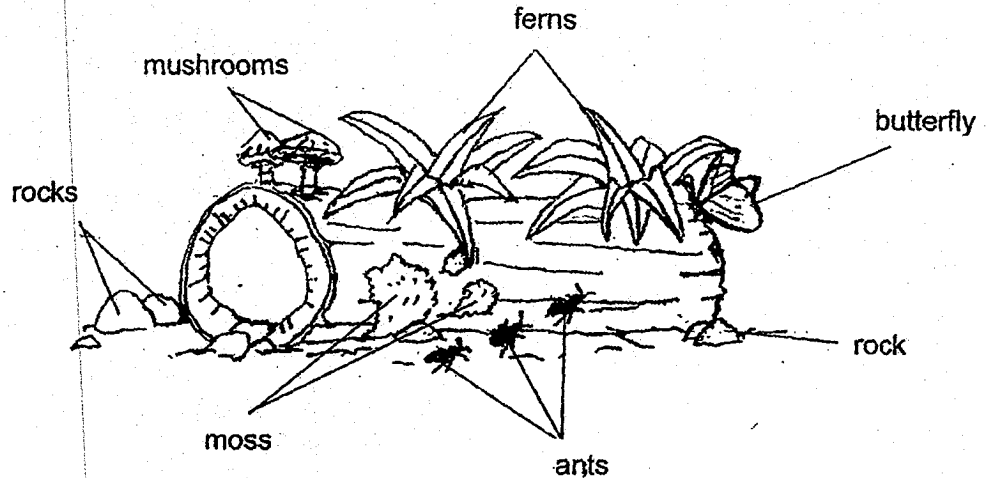

Based only on the diagram above which of the following statements are correct?

- A There is only one community.
- B There are two populations of fungi.
- C There are two populations of plants.
- D There are two populations of insects.

- (1) A and C only
- (2) B and D only
- (3) A, C and D only
- (4) B, C and D only

2. The table below shows 3 organisms grouped according to 2 physical factors, X and Y, that are found in the environment they live in.

Organism	Physical Factor X	Physical Factor Y
K	Low	High
Water hyacinth	High	High
Earthworm	High	Low

John found that organism K preferred bright and dry environments. Which of the following best represents physical factors X and Y, and the habitat that organism K can be most likely found in?

	Physical factor X	Physical factor Y	Habitat
(1)	Light	Moisture	Desert
(2)	Moisture	Light	Pond
(3)	Light	Moisture	Pond
(4)	Moisture	Light	Desert

3. The diagram below shows the food relationships among organisms found in the desert. The cactus provides shelter for organism B.

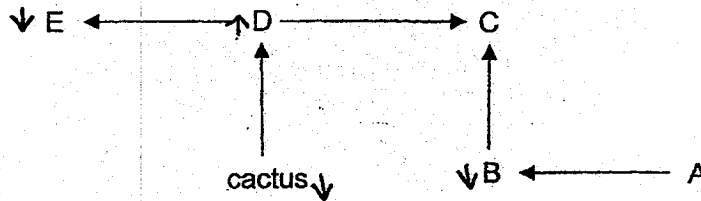

After hunters have killed most of organism E, the population of organism C still remains constant. How would the population of the cactus and animal B be affected?

	Cactus	Organism B
(1)	Increase	Increase
(2)	Increase	Decrease
(3)	Decrease	Increase
(4)	Decrease	Decrease

4. The diagram below shows a food web.

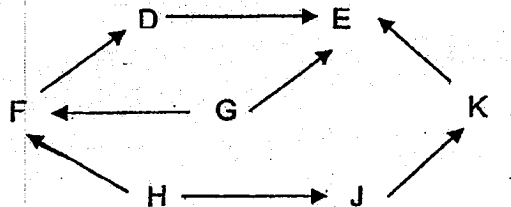

Rahman made three statements about the food web above.

- A There are six food chains.
- B There are five consumers.
- C J is both a prey and a predator.

Which statement(s) is/are correct?

- (1) only
- (2) B only
- (3) and B only
- (4) A, B and C

5. A type of dolphins was observed to swim around a school of fish and guide them towards a fisherman's boat. The dolphins feed on the small fish that escape from the fisherman's net.

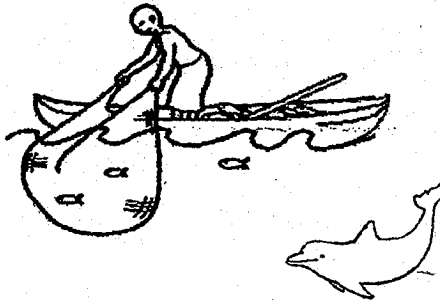

Based only on the information above, which one of the following correctly states and explains the relationship between dolphins and man?

	Relationship	Reason
(1)	Dolphins benefit, man is harmed	Dolphins have man's protection from predators, but man loses money with less fish caught.
(2)	Man benefits, dolphins do not benefit	Man can control dolphins and dolphins are their servants.
(3)	Both man and dolphins benefit	Man can catch more fish and dolphins have food to eat.
(4)	Neither dolphins nor man benefits	Man has fish stolen by dolphins and dolphins are hunted by man.

6. The diagram below shows insect X which is a plant-eater.

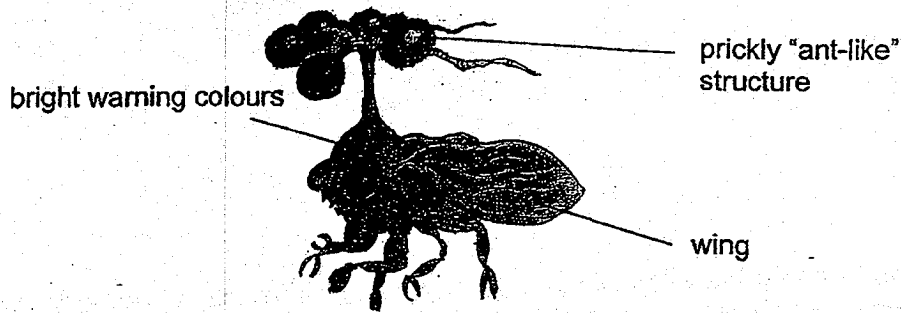

Insect X has a large "ant-like" structure on its head. The "ant-like" structure is light and has prickly spikes.

Which of the following characteristic(s) help to protect insect X from its predators?

Characteristics		
Bright warning colours	Wings	Prickly "ant-like" structure
(1) Yes	No	No
(2) No	Yes	No
(3) No	Yes	Yes
(4) Yes	Yes	Yes

7. The graphs below show a population of animal W. Animal W eats grass grown at either locations S or K over a period of a year.

Number of animal W

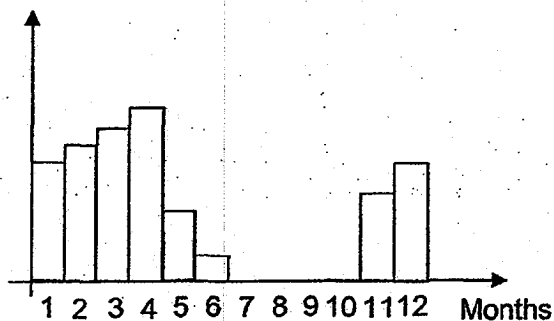

Location S

Number of animal W

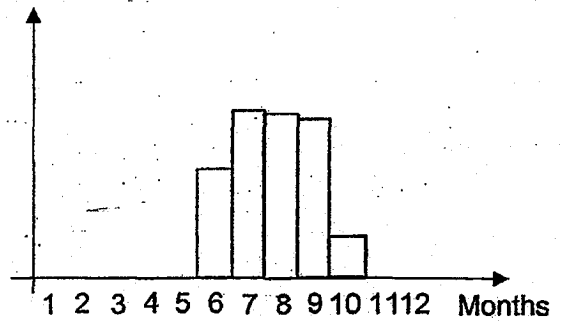

Location K

Based on the information given, which of the following statement is likely to be correct?

- (1) Animal W was able to survive in places with very low rainfall.
- (2) Animal W was completely killed off several times during the year.
- (3) More grass was available at location K than S from months 7 to 9.
- (4) The birth rate of animal W decreased and its death rate increased from months 2 to 4.

8. The diagram below shows animal C

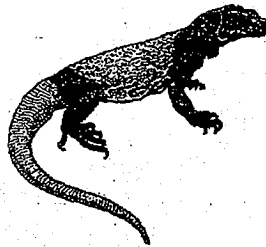

The following are adaptations that animal C uses to help it survive in its habitat. Which of these are behavioural adaptations?

- A Shakes its head to communicate.
- B Hibernates when the weather turns cold.
- C Males are more colourful than females to attract mates.
- D Inflates itself in small spaces to avoid being pulled out by its predators.

- (1) B and C only
- (2) C and D only
- (3) A, B and C only
- (4) A, B and D only

9. Which one of the following does not ensure that an organism will survive till adulthood?

- (1) Eggs are laid in a shelter.
- (2) Eggs are laid near a food source.
- (3) Eggs are laid in large numbers each time.
- (4) Eggs are not cared for by the adult organism.

10. The diagram below shows fish P.

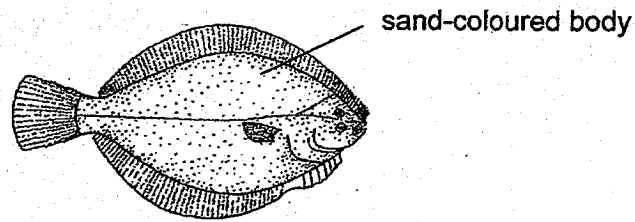

Fish P is streamlined, has both eyes on one side of its body. It eats other fish and is often found flat on the seabed covering its body, except its eyes, with sand.

Based on the information above, which of the following reasons for fish P's adaptations are correct?

	Adaptation	Reason
A	Has a streamlined body	Swims quickly to catch its prey
B	Has a sand-coloured body	Blends into its environment to prevent its prey from spotting it
C	Covers its body with sand	Anchors it to the bottom of the sea
D	Has both eyes on one side of its body	Keeps it warm

- (1) A and B only
 (3) C and D only

- (2) B and C only
 (4) A, B and C only

11. Which one of the following is not a method to reduce overfishing?

- (1) Remove predators of the fish.
 (2) Impose fines on excess fish caught.
 (3) Allow only larger sized fish to be caught.
 (4) Allow only certain areas of the sea to be used for fishing.

12. Some scientists studied the effect of carbon dioxide on the number of mosquitoes in country X. These mosquitoes cause the spread of dengue

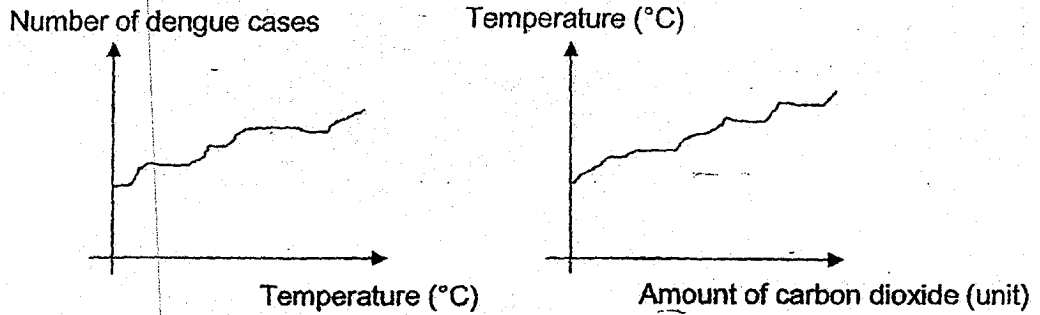

Based on the graphs above, which of the following could have caused the increase in the number of dengue cases?

- A Increase in deforestation
- B Increase in the usage of fossil fuels
- C Decrease in the use of plastic straws

- (1) A and B only
- (2) A and C only
- (3) B and C only
- (4) A, B and C

13. Jasmyn set up an experiment using similar seeds in a warm room as shown below.

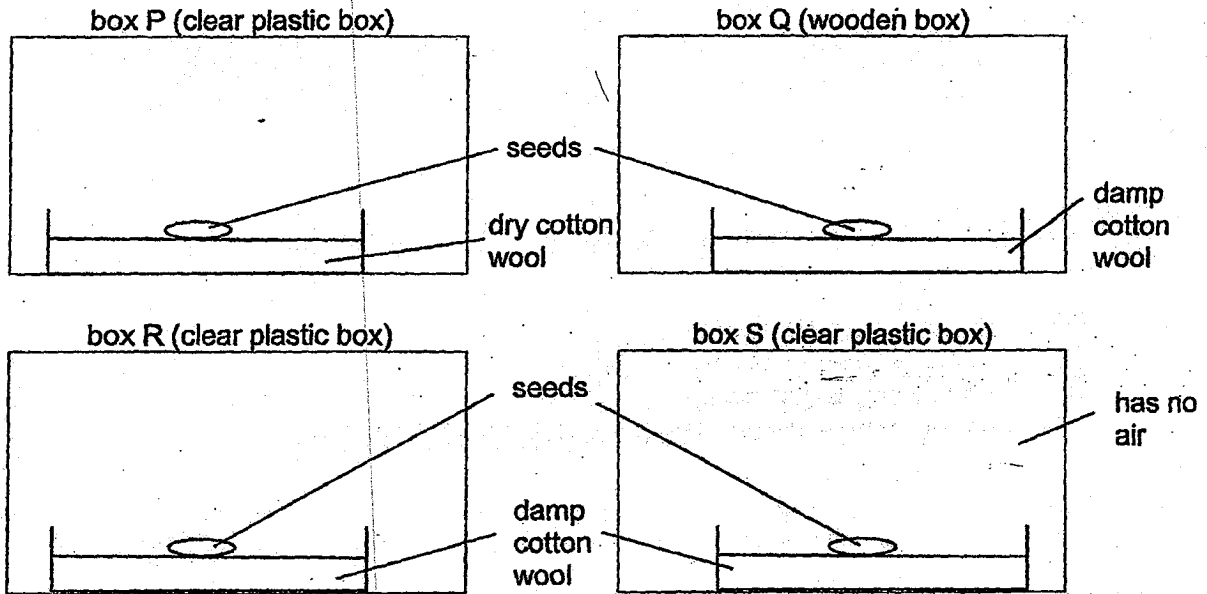

In which box(es) could the seed germinate?

- (1) R only
- (2) P and S only
- (3) Q and R only
- (4) Q and S only

14. Study the table below.

Reproductive part	Function
J	Where eggs are produced
K	To receive the sperm
L	To produce the sperm
M	Where a fertilised egg develops

Which one of the following diagrams has been labelled correctly based on the functions above?

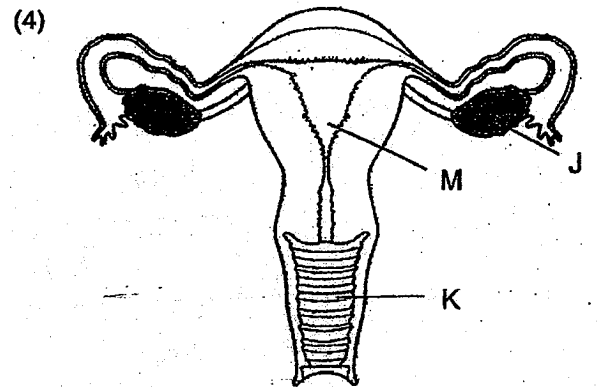
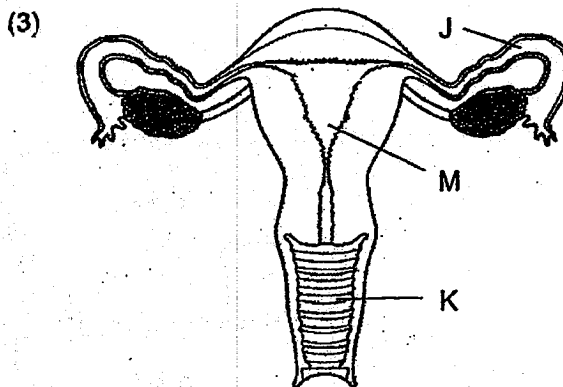
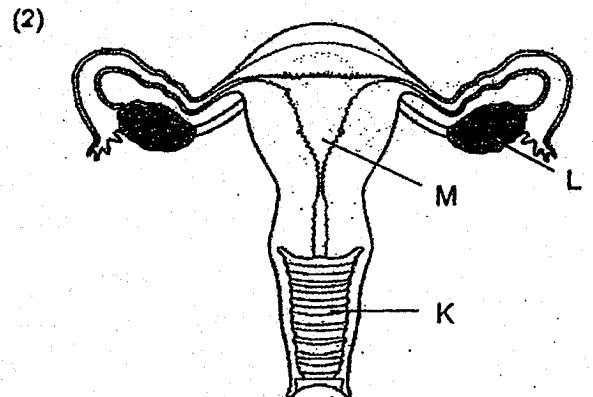
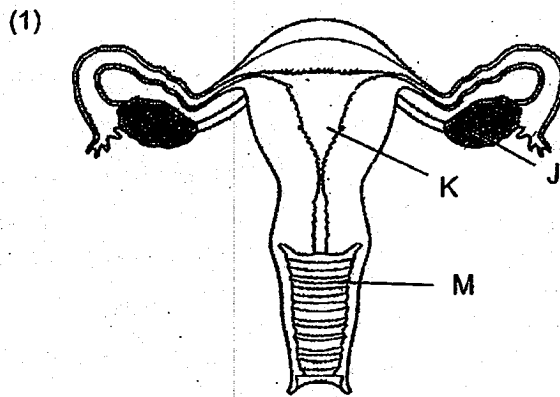

15. The table below shows the amount of carbon dioxide found in blood samples collected from blood vessels, A, B, C and D, in the human body.

Blood vessels	Amount of carbon dioxide in blood sample (units)
A	low
B	high
C	high
D	low

Which one of the following diagrams correctly identifies blood vessels A, B, C and D?

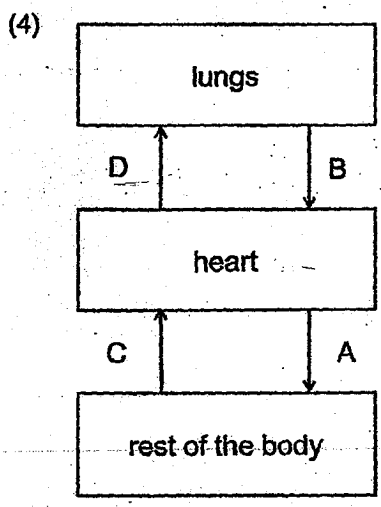
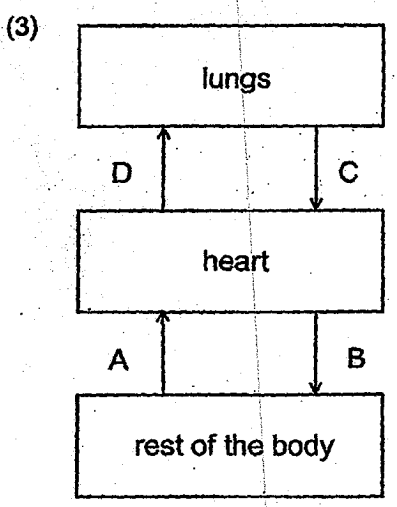
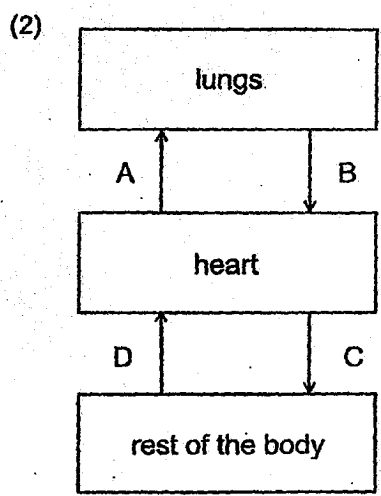
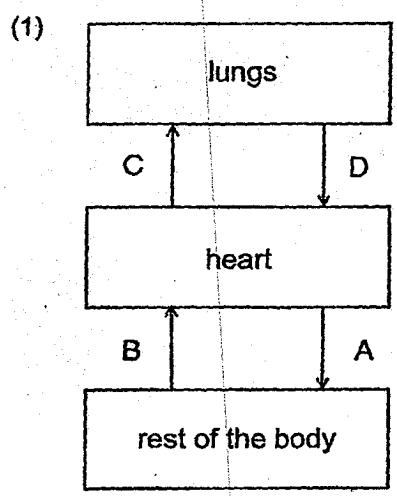

16. Which of the following correctly describes the functions of the digestive system?

- A To remove water from undigested food
- B To break down food into smaller pieces
- C To transport digested food around the body
- D To break down food into simpler substances

(1) A and C only

(2) B and D only

(3) A, B and C only

(4) A, B and D only

17. John cut down a tree to set up a campfire as shown in the diagram below.

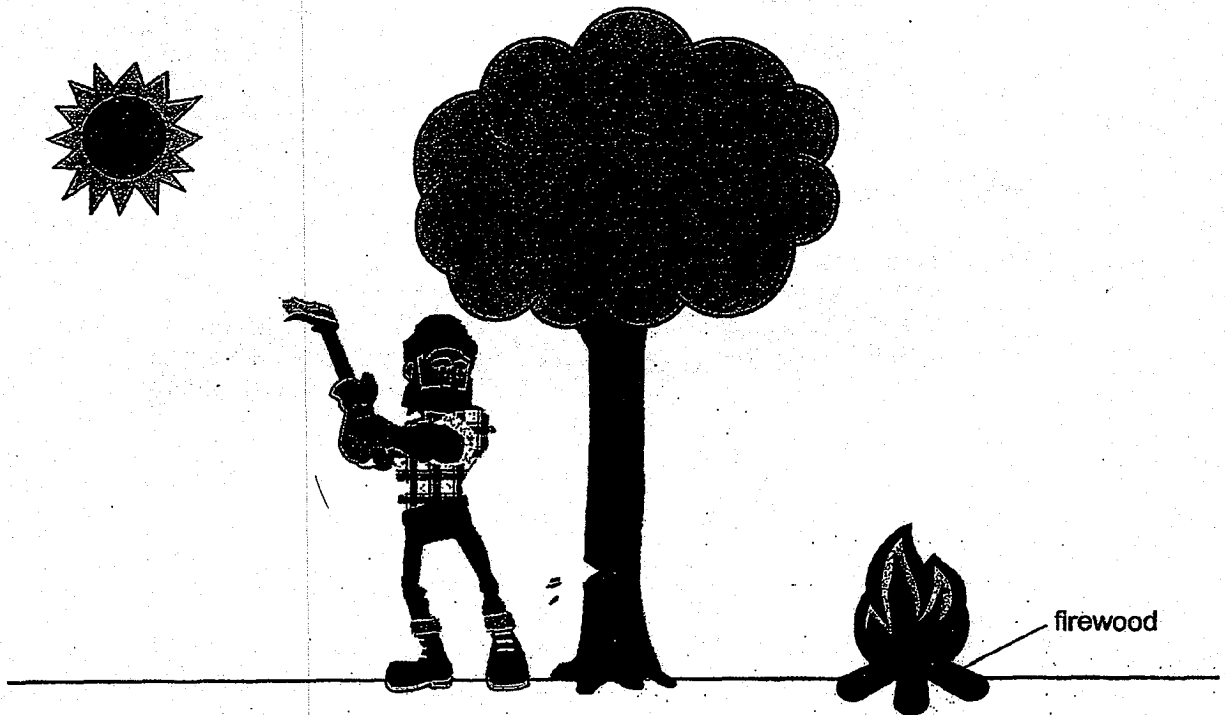

Which one of the following shows the main energy conversion?

	Energy from the Sun		Energy of the firewood		Energy of the fire
(1)	light energy	→	heat energy	→	light energy
(2)	potential energy	→	potential energy	→	heat energy
(3)	light energy	→	potential energy	→	heat energy + light energy
(4)	heat energy	→	potential energy	→	heat energy + light energy

18. Four similar-sized blocks, P, Q, R and S, were set up as shown below.

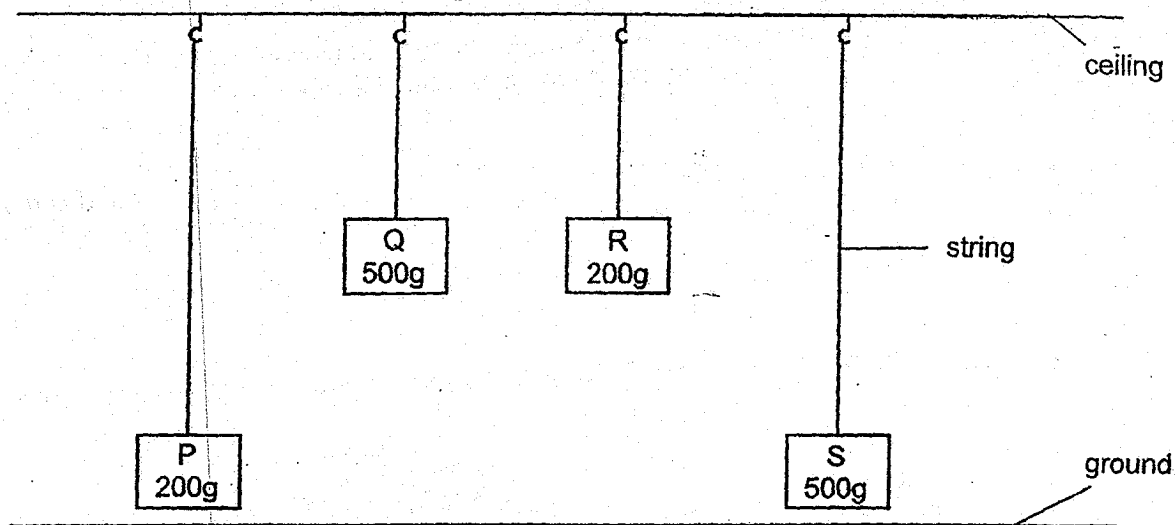

Which one of the following statements is correct?

- (1) R has less gravitational potential energy than P.
- (2) Q has the greatest amount of gravitational potential energy.
- (3) P and S have the same amount of gravitational potential energy.
- (4) Q and S have the same amount of gravitational potential energy.

19. A marker pen holder with a magnet in it was attached to a whiteboard made of magnetic material. A weight was then added to the holder and the holder started to slide down while still being attracted to the whiteboard as shown in the diagram below.

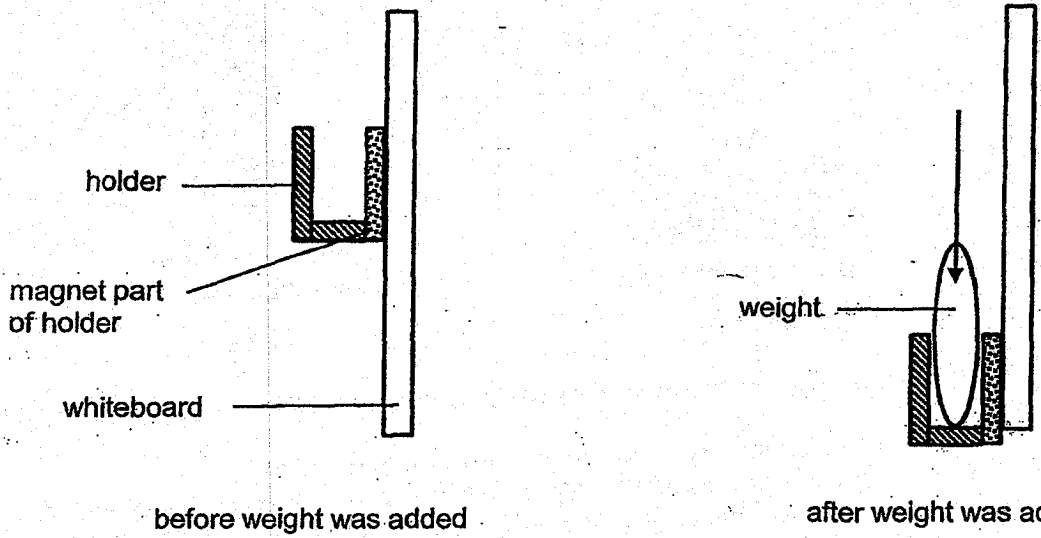

Which of the following forces were present when the holder was sliding down the whiteboard?

- A frictional force
- B gravitational force
- C elastic spring force
- D magnetic force of attraction

- (1) A and B only
- (3) C and D only

- (2) B and D only
- (4) A, B and D only

20. A very elastic spring of original length 20 cm was hung from a ceiling and came to rest as shown below.

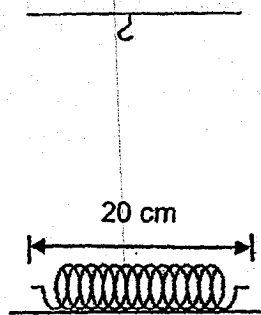

before experiment

Figure 1

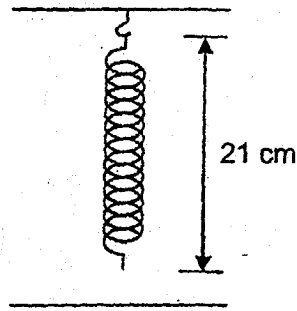

spring hung from a ceiling

Figure 2

Which of the following statement(s) is/are correct about the spring in figure 2 above?

- A Gravitational force has caused the spring to extend.
- B There is less elastic spring force in the spring when it was extended.
- C There is more gravitational force acting on the spring after it was hung from the ceiling.

- (1) A only
- (3) A and C only

- (2) A and B only
- (4) B and C only

21. Ameenah set up the circuit as shown below to test if object R conducts electricity. She then repeated the experiment by replacing object R with object S.

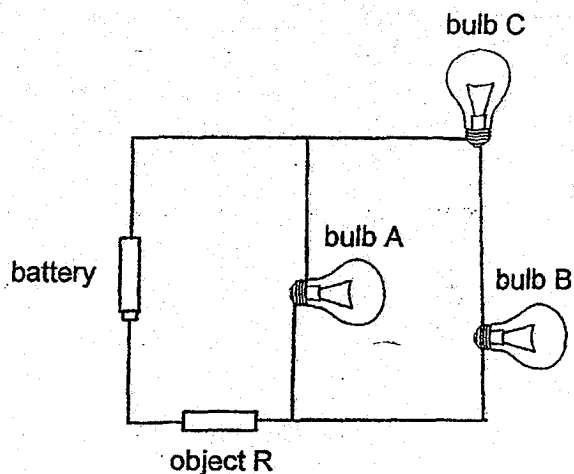

The table below shows her observations.

Object	Observations		
	Bulb A	Bulb B	Bulb C
R	light up brightly	did not light up	light up brightly
S	light up dimly	did not light up	light up dimly

Based on the observations above, which of the following statements are correct?

- A Object R is a conductor of electricity.
- B Object S does not allow electricity to pass through.
- C There is no electricity passing through the filament of bulb B.
- D Less electricity passes through bulb A than through bulb C in both experiments.

- (1) A and B only
- (3) C and D only

- (2) A and C only
- (4) A, B, C and D

22. Study the four circuit diagrams below.

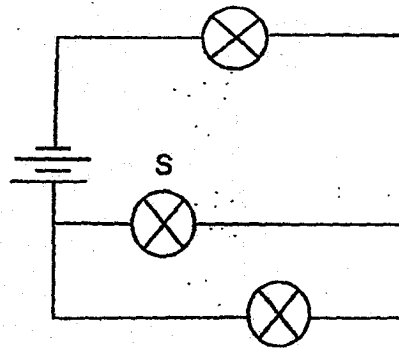
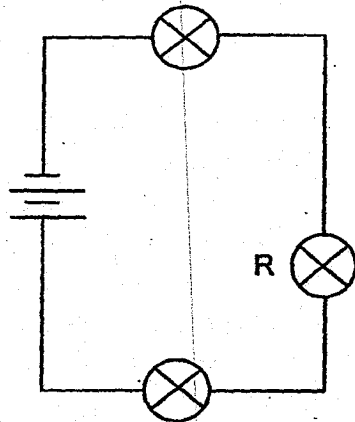
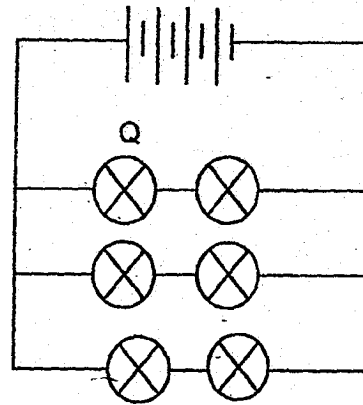
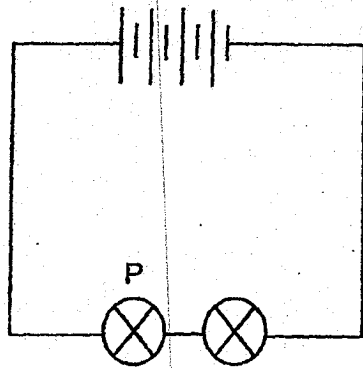

Which two bulbs would have the same brightness?

- (1) P and Q
- (2) P and S
- (3) R and S
- (4) Q and R

23. James plugs in many appliances into a single socket as shown in the diagram below.

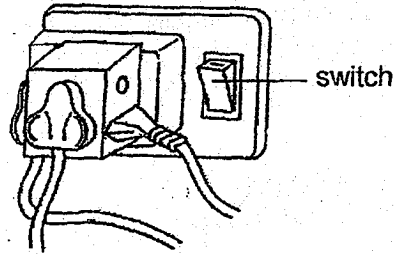

The diagram below shows the arrangement of the appliances to show the connection above.

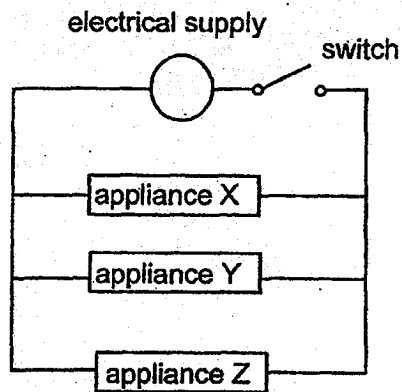

many appliances
connected to one socket

Based on the information above, which of the following statement(s) is/are correct?

- A When the switch is switched off, all the appliances can no longer work.
- B When one appliance fuses, the rest of the appliances will continue to work as electricity can flow through them.
- C When many appliances are connected to one socket, more electricity passes through appliance X than appliance Y.

- (1) A only
- (3) A and C only

- (2) A and B only
- (4) B and C only

24. Jake is in a completely dark room with several objects.
Which of the objects below would he be able to see?

- A A mirror
- B A sheet of black paper
- C A sheet of white paper
- D A piece of aluminium foil

- (1) A and D only
- (2) B and C only
- (3) A, C and D only
- (4) None of the above

25. Sets of two blocks, A and B, of different sizes were placed side by side. Both blocks A and B are made of the same metal. The temperature of each block at the start of the experiment is indicated in the diagram below.

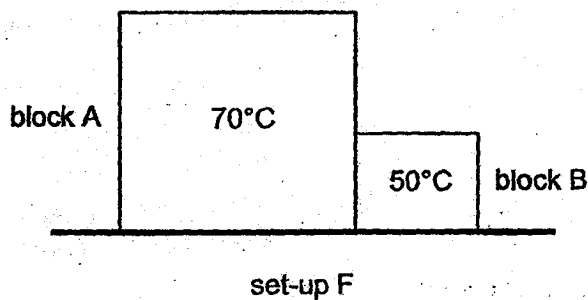
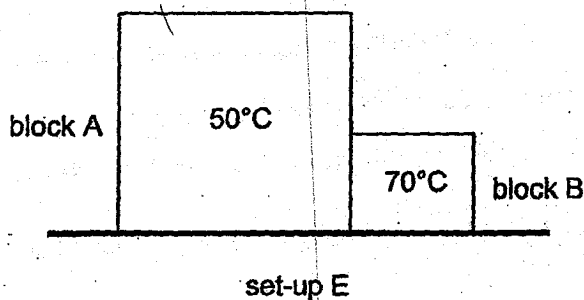
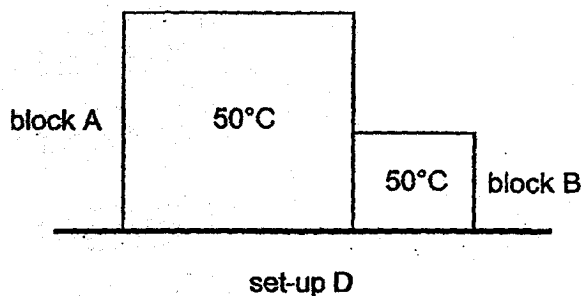

In which of the set-up(s) will the temperature of block B increase immediately after being placed beside block A?

- (1) E only
- (2) F only
- (3) D and E only
- (4) E and F only

26. A sealed plastic bag of air was left on an electronic balance under the sun for 4 hours as shown below.

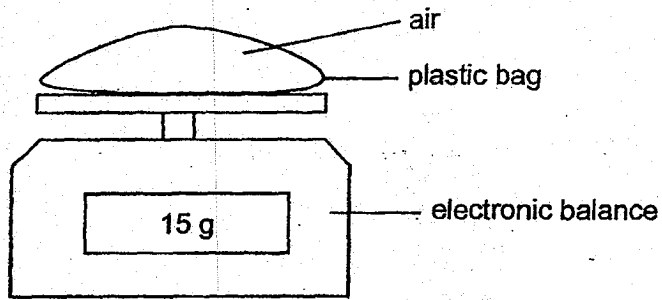

Start of experiment

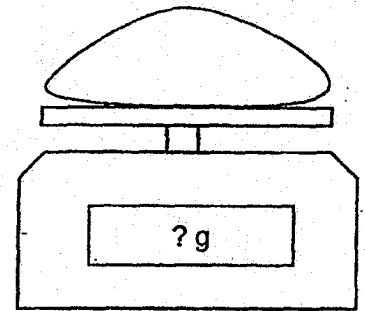

End of experiment

Which of the following statements about the set-up at the end of the experiment are correct?

- A The air in the plastic bag expanded.
- B The mass of air in the plastic bag increased.
- C The volume of air in the plastic bag decreased.
- D The reading on the electronic balance remained the same.

(1) A and D only

(3) A, B and D only

(2) B and C only

(4) A, C and D only

Study the diagram below and answer Questions 27 and 28.

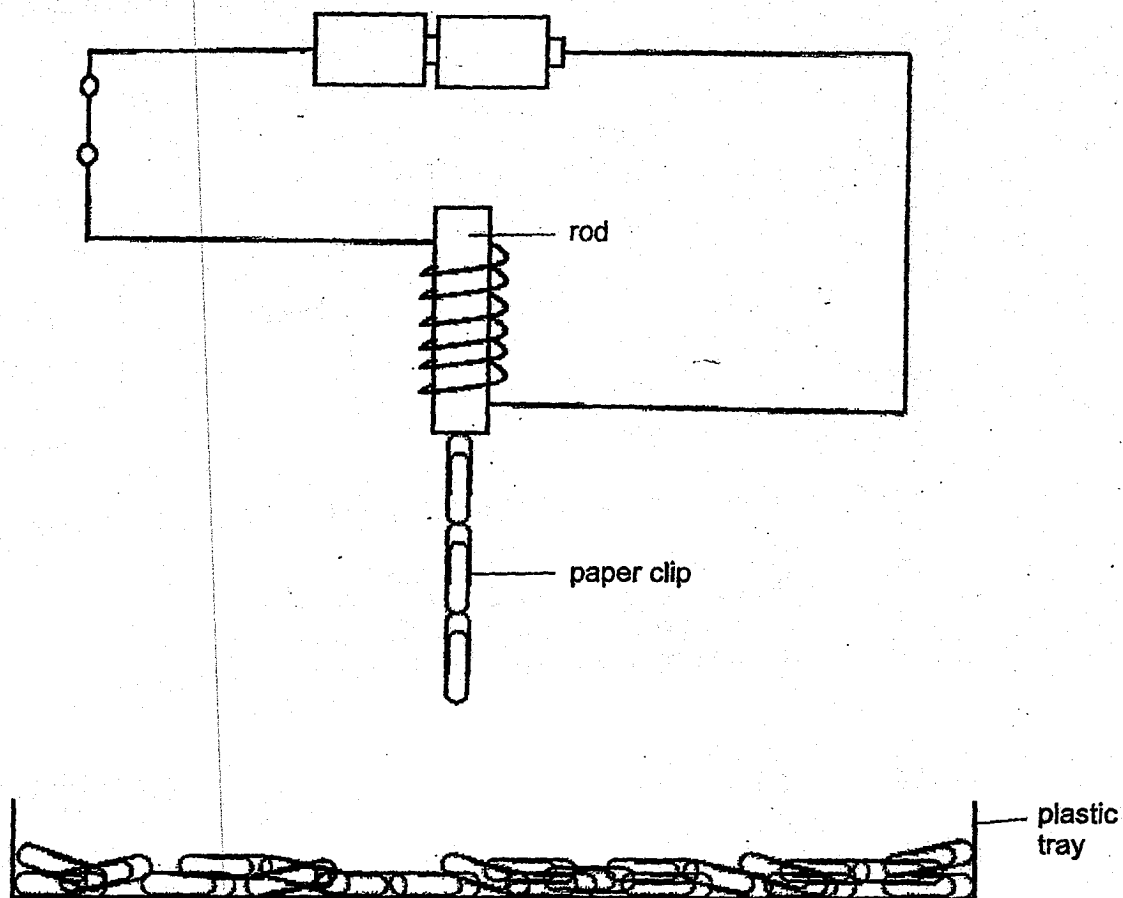

27. Which of the following are materials that the rod can be made of?

- A iron
- B steel
- C wood
- D copper

- (1) A and B only
- (3) C and D only

- (2) B and C only
- (4) A, B and D only

28. Abby added an additional battery to the set-up as shown below.

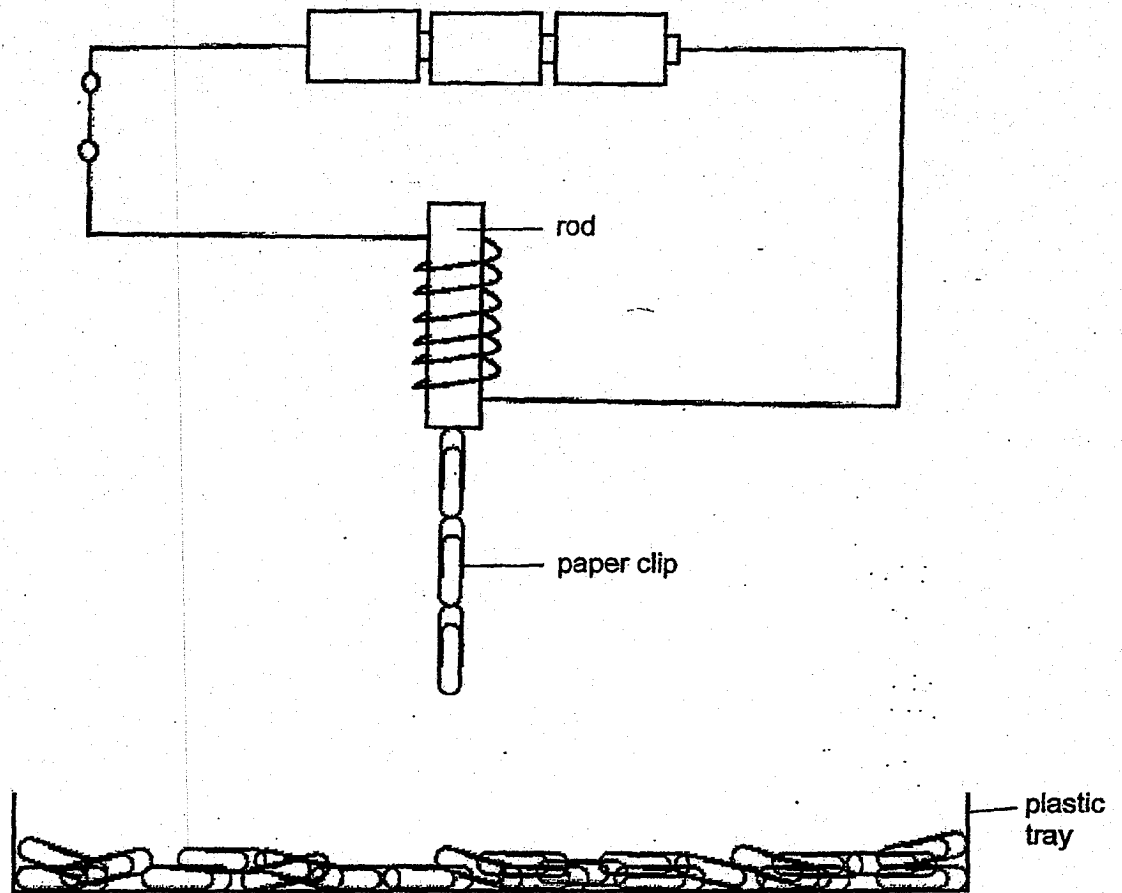

She observed that the number of paper clips attracted by the magnetised rod did not increase.

Which of the following are possible reasons for her observation?

- A The battery added had no energy.
- B The wire could not conduct electricity.
- C The other paper clips in the tray were made of non-magnetic materials.

- (1) A only
- (3) B and C only

- (2) A and C only
- (4) A, B and C

~ END OF BOOKLET A ~

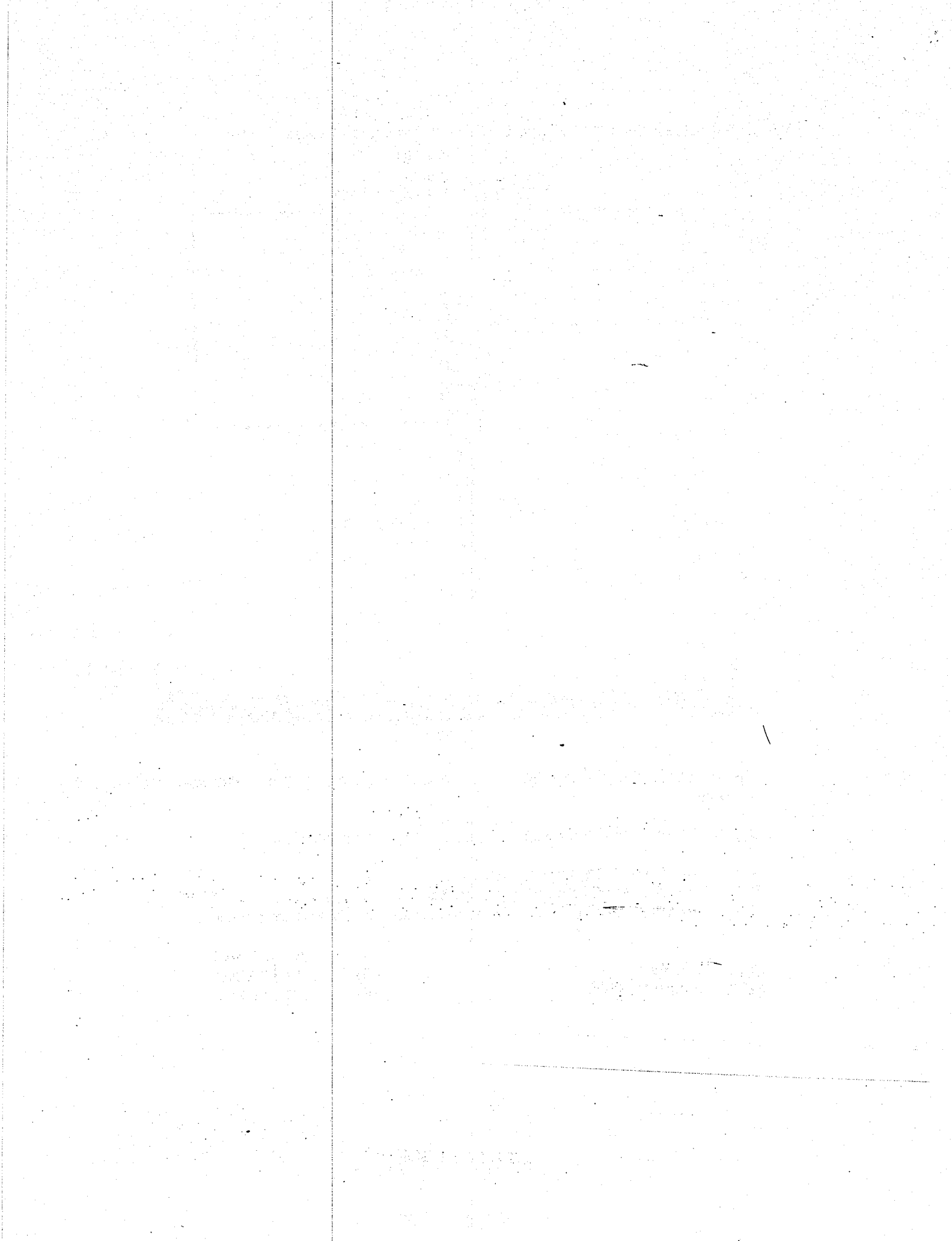

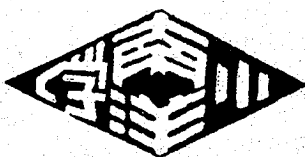

NANYANG PRIMARY SCHOOL

PRIMARY 6 SCIENCE

PRELIMINARY EXAM
2019

BOOKLET B

Date : 23 August 2019
Duration : 1 h 45 min

Name : _____ ()

Class: Primary 6 ()

Marks Scored:

Booklet A:		56
Booklet B :		44
Total :		100

Any query on marks awarded should be raised by 2 September 2019. We seek your understanding in this matter as any delay in the confirmation of marks will lead to delays in the generation of results.

Parent's signature:

**DO NOT OPEN THIS BOOKLET UNTIL YOU ARE TOLD TO DO SO.
FOLLOW ALL INSTRUCTIONS CAREFULLY.**

Booklet B consists of 17 printed pages including this cover page.

Section B

Write your answers to questions 29 to 40 in the spaces provided.

29. A farmer set up an experiment to find out how the number of plants grown on a plot of land affected the height of the plants.

His results are shown in the graph below.

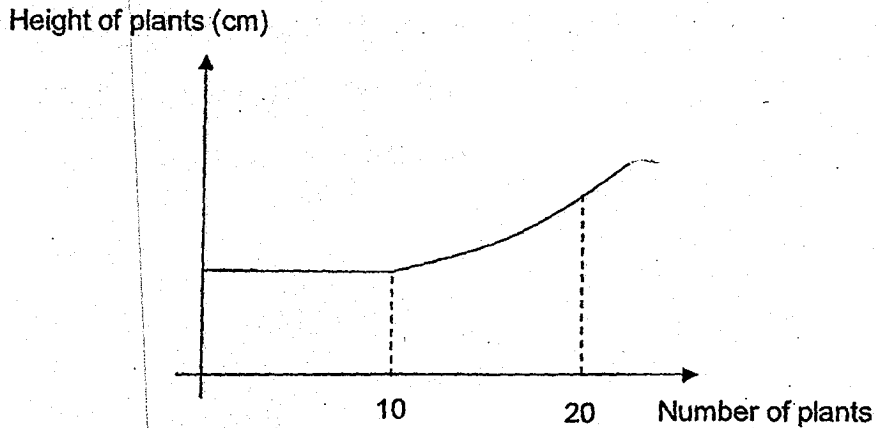

- (a) What is the relationship between the number of plants grown and the height of the plants? [2]

The diagram below shows a seedball. It contains seeds in a mixture of soil and mineral salts. The farmer observed that when he used a seedball containing 20 seeds, the seedlings appeared tall and unhealthy,

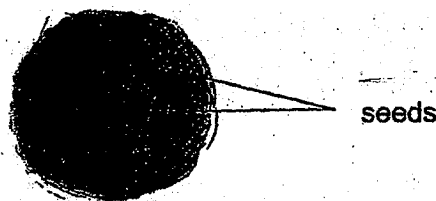

- (b) Explain why using seedballs with more than 10 seeds leads to taller and healthier seedlings. [1]

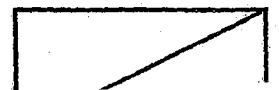

Throwing seedballs is a technique used to disperse many seeds quickly for reforestation. Seedballs of plant P were released from airplanes over location X.

The graph below shows how the amount of rainfall changes at location X over a year.

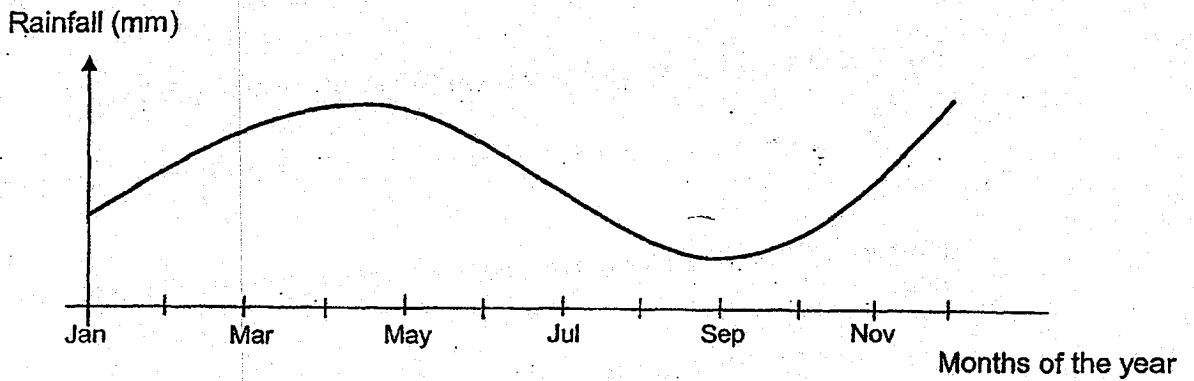

- (c) Based on the graph above, explain why despite releasing a large number of seedballs of plant P in September, the population of plant P remained low. [1]

- (d) The diagram below shows a seed. Draw and label the part that will appear first when it germinates. [1]

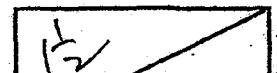
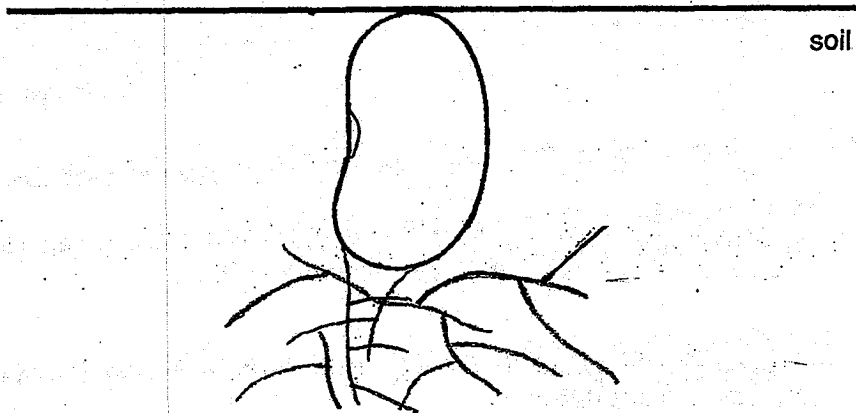

30. The table below shows the food relationships among organisms S, T and U in a habitat.

Relationship	Organism
Prey	S
Predator	T
Producer	U

(a) State the food chain found in the habitat above using S, T and U. [1]

The graph below shows how the number of organisms S and T change over a period of time.

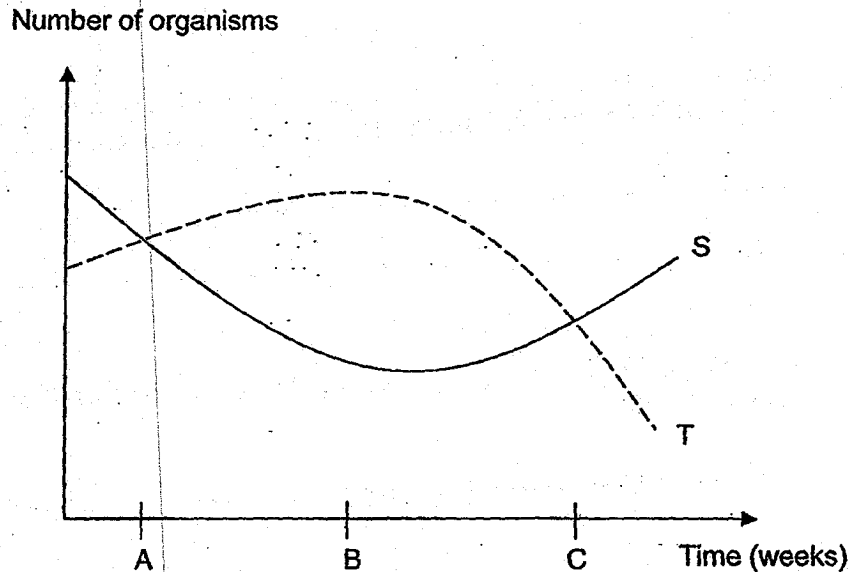

Several organisms R, which feeds on T, were released into the habitat during the year.

(b) Circle the letter A, B or C on the horizontal axis in the graph above to show when organism R was likely introduced into the habitat. [1]

(c) Explain why the population of organism U decreases when R has no natural predators in this habitat. [1]



31. Simon conducted an experiment using 3 objects made of the same material. All the objects had the same volume. He placed all 3 objects on a table in a room at 30°C. He measured the temperature of the objects after 5 minutes. His results are shown in the table below.

Block	Exposed surface area (cm ²)	Start temperature (°C)	Final temperature (°C)
A	24	80	56
B	28	80	44
C	32	80	36

- (a) State the relationship between the exposed surface area of the object and the amount of heat lost by the object. [1]

Animals G and H shown below are found in different parts of the world. Animal G has a greater exposed surface area to its surroundings than animal H.

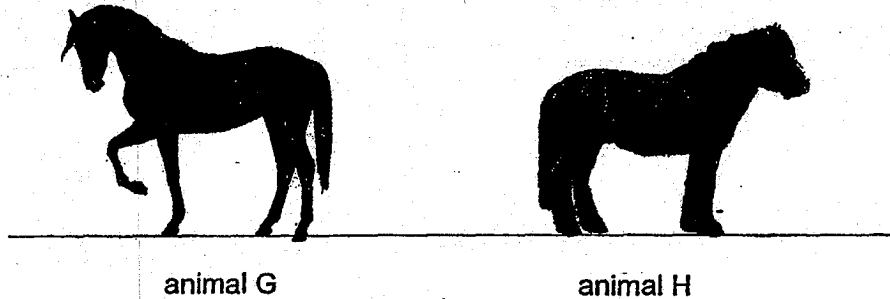

- (b) Based on the results of Simon's experiment, explain why animal G is more likely to be found living in a hot environment. [1]

- (c) Animal H has a thick layer of hair around its body. Explain how the thick layer of hair helps animal H survive in a cold environment. [2]



32. The diagram below shows fruits, W, X, Y and Z, which have been cut open.

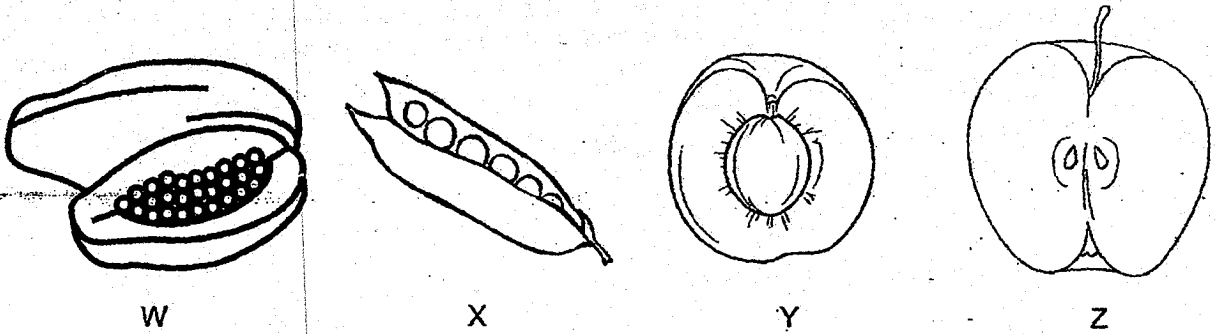

(a) Fill in the classification chart below with fruits W, X, Y and Z.

[1]

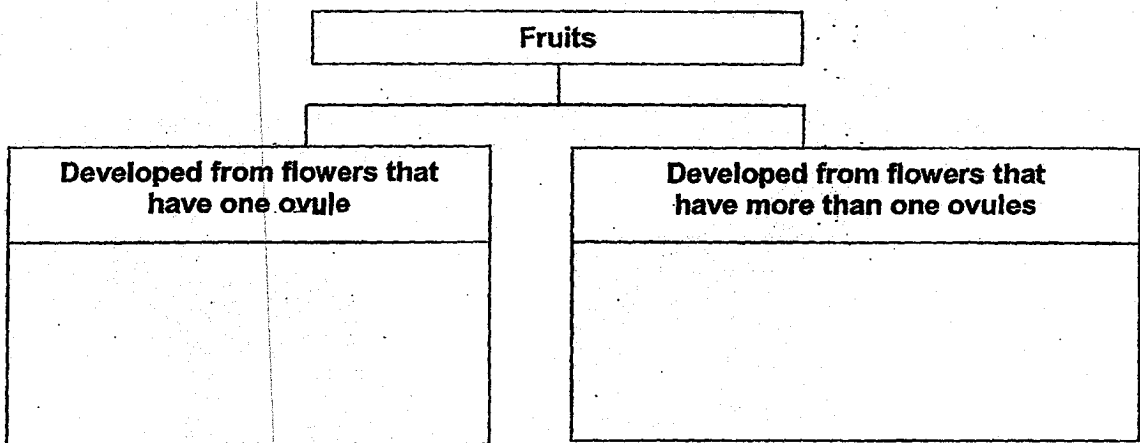

Evan and Fion obtained part P from a plant and cut it in half as shown in the diagram below.

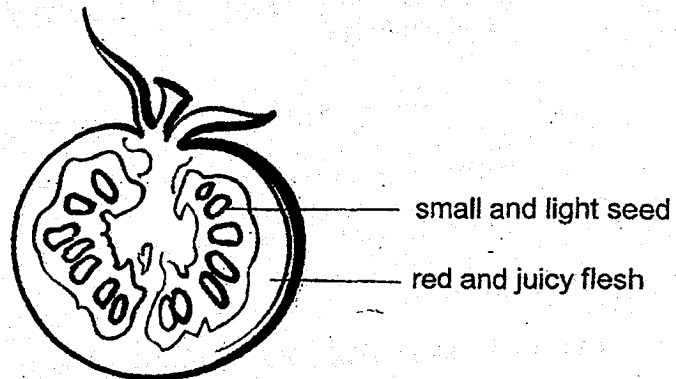

Part P

They made the following statements.

Evan: Part P came from a non-flowering plant.

Fion: The seeds of part P are dispersed by wind because they are small and light.

Their teacher said that both their statements were incorrect.

(b)(i) Based on the diagram, explain why Evan is wrong.

[1]

(b)(ii) Based on the diagram, explain why Fion is wrong.

[1]



33. Aisha was told that she needed to eat food in order to have energy to carry out activities.

(a) Describe what happens to the digested food after it passes through the walls of the small intestine. [2]

The graph below shows Aisha's heart rate while she was performing different activities.

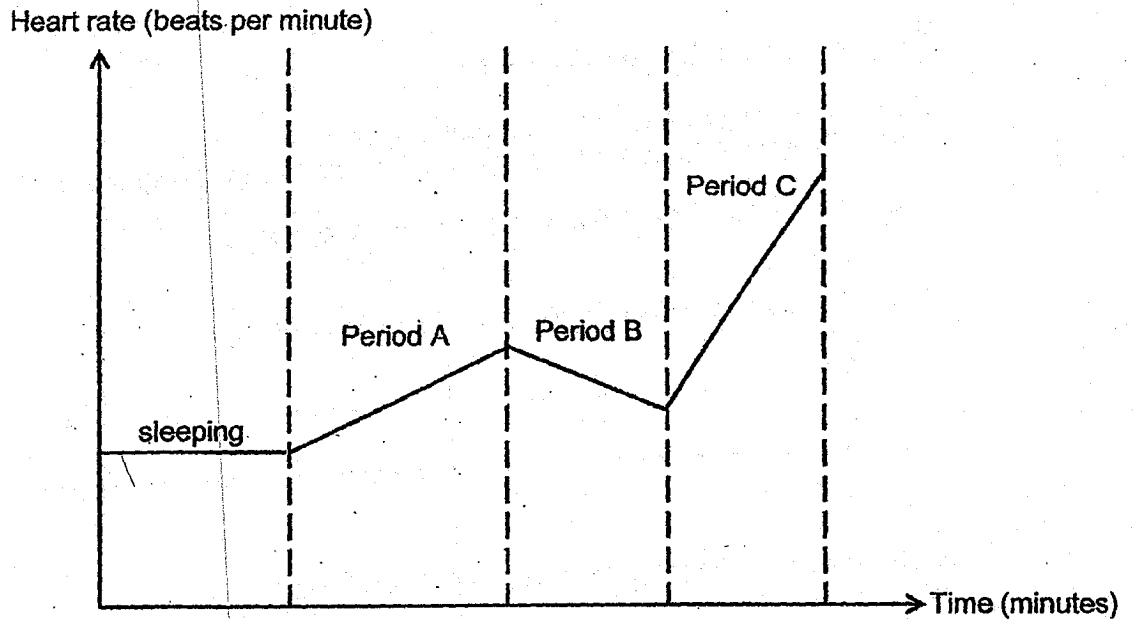

(b) Match the following activities to the periods, A, B and C, shown above. [1]

Activity	Period
Running	
Reading	
Sweeping	



34. The table below shows the average time taken for food to travel through the stomach of a healthy person and the stomach of Zach, who has a condition that causes all his muscles to become weaker over time.

Due to his condition, Zach has to put on the equipment as shown in the diagram below on his leg to help him walk without falling.

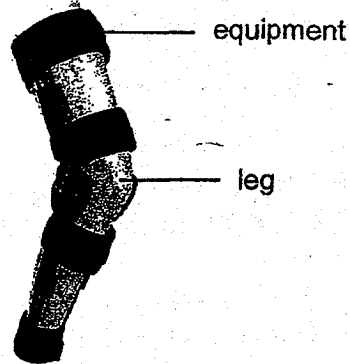

- (a) State the human body system other than the muscular system that serves a similar function as the equipment above. [1]

- (b) What is the similarity in function between the body system mentioned in (a) and the equipment above? [1]



35. A ball was released from point P of a ramp. It rolled down through points Q and R and came to a stop at point A as shown in the diagram below.

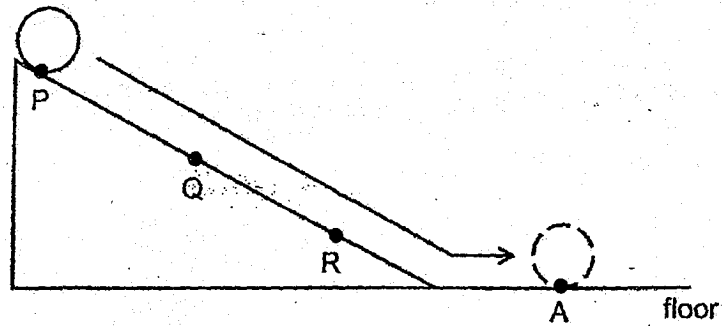

- (a) Fill in the table below with a tick (✓) to correctly show the change in the different types of energy that the ball has from point P to point R. [1]

Types of energy	Increases	Decreases	Remains the same
Potential energy			
Kinetic energy			
Heat energy			

Georgina then applied some oil on the ramp and repeated the experiment.

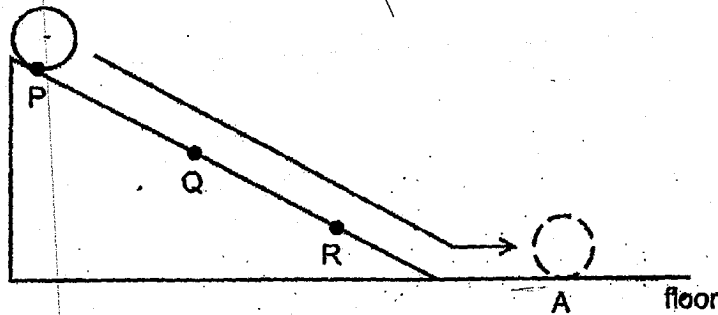

- (b)(i) In the diagram above, mark with an 'X' the position where the ball will most likely stop. [1]
- (b)(ii) In terms of energy conversion, explain your answer in (b)(i). [1]



Georgina wanted to show how she could use a metal ball to ring a bell. She arranged the set-up as shown below.

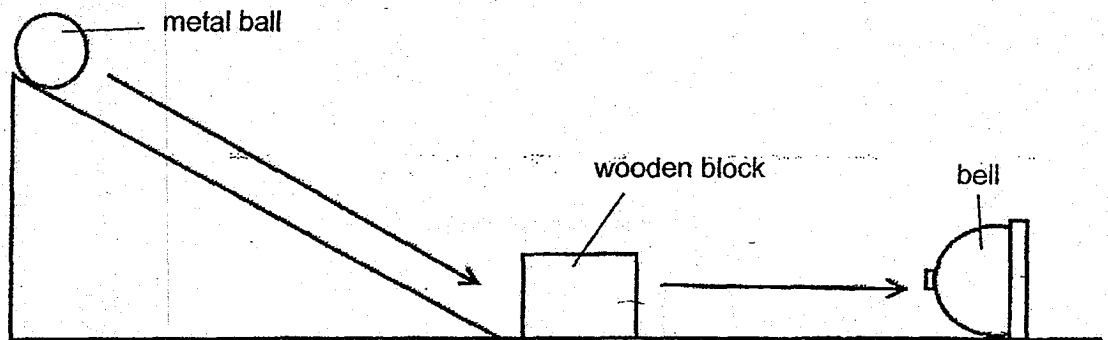

(c) Fill in the boxes below to show the main energy conversion in the set-up above. [2]

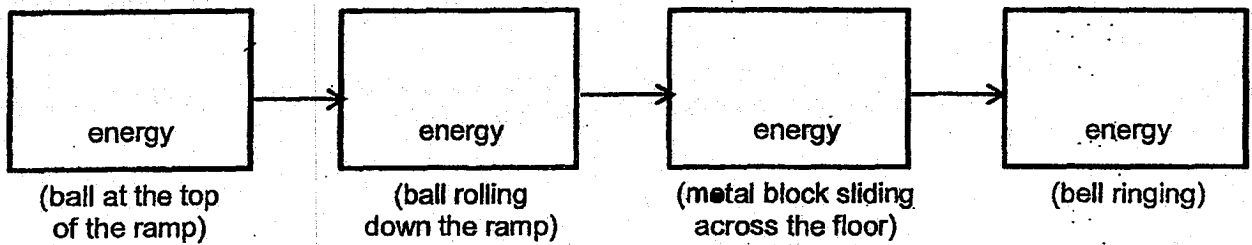

36. An experiment was conducted to find out the height reached by an object using a spring compressed to different lengths as shown below.

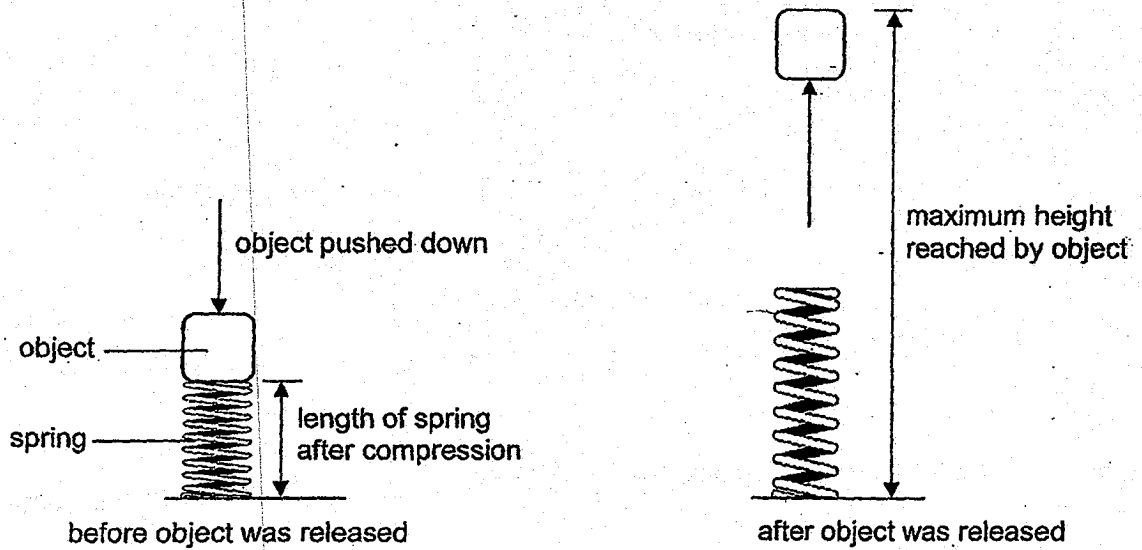

- (a) The spring can be compressed to the shortest length of 10 cm. Draw a line graph below to show the most likely results obtained. [1]

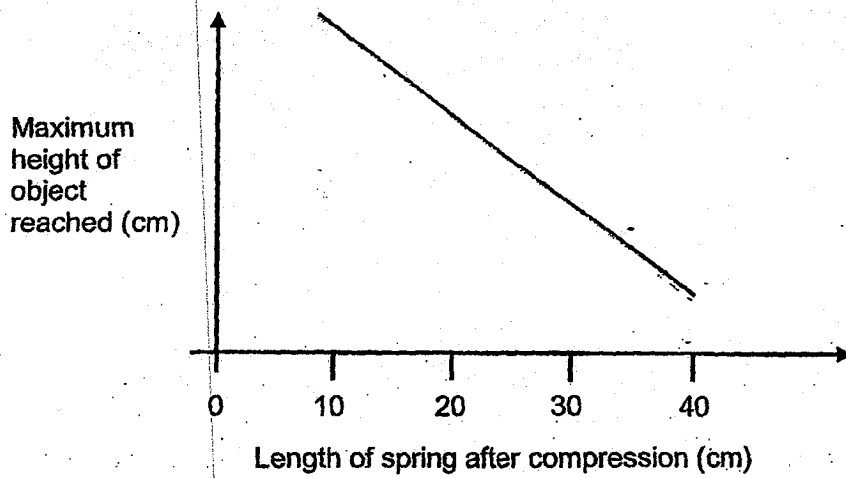

The diagram below shows a jumping shoe made up of a shoe and a spring.

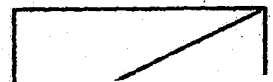
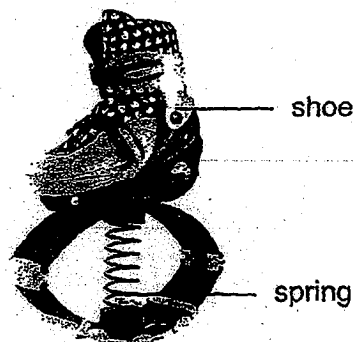

The diagram below shows the maximum height reached by the same user when jumping with and without the shoes.

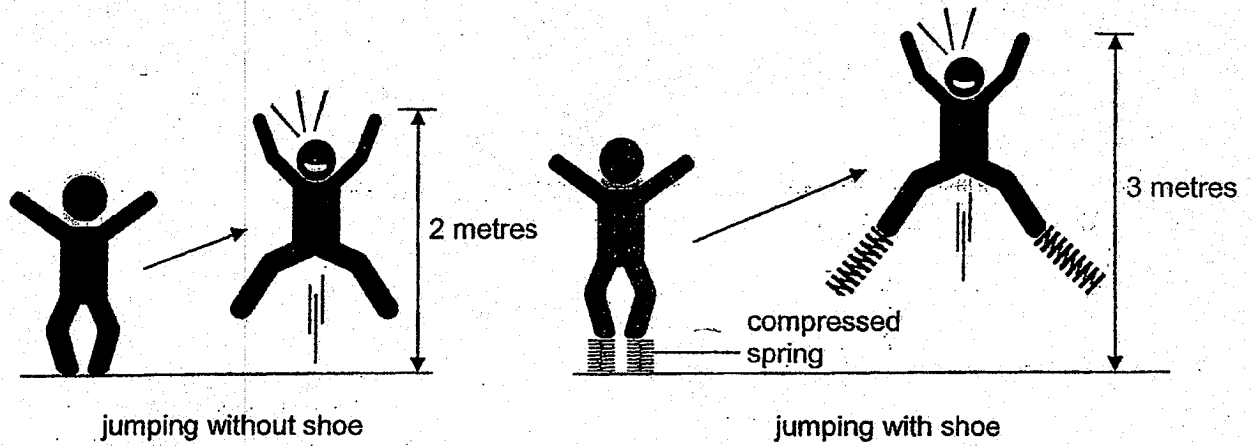

(b) In terms of forces, explain the effects of jumping with the shoes on. [2]

John bought a new pair of jumping shoes which has a stiffer spring.

(c) Complete the table below to show the maximum height reached by the same user when jumping with this new pair of shoes. [1]

Jumping shoe	Maximum height reach (m)
With original spring	3
With stiffer spring	

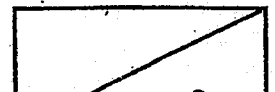

37. Glenda created a battery-operated warning light system as shown below. It has an extra light bulb so that she can still be alerted if one of the bulbs fuses.

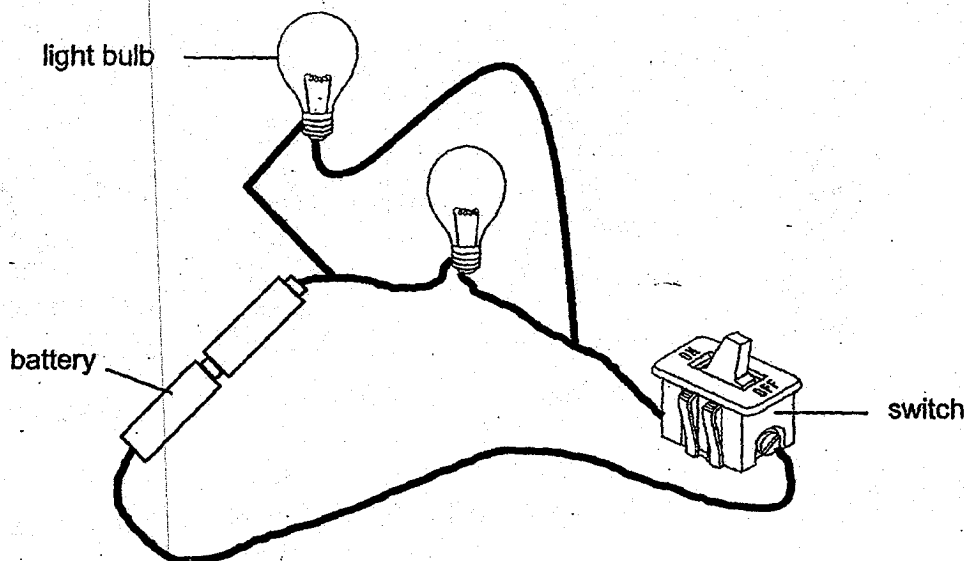

- (a) In the box below, draw and label a circuit diagram of Glenda's warning light system based on the diagram above. [2]

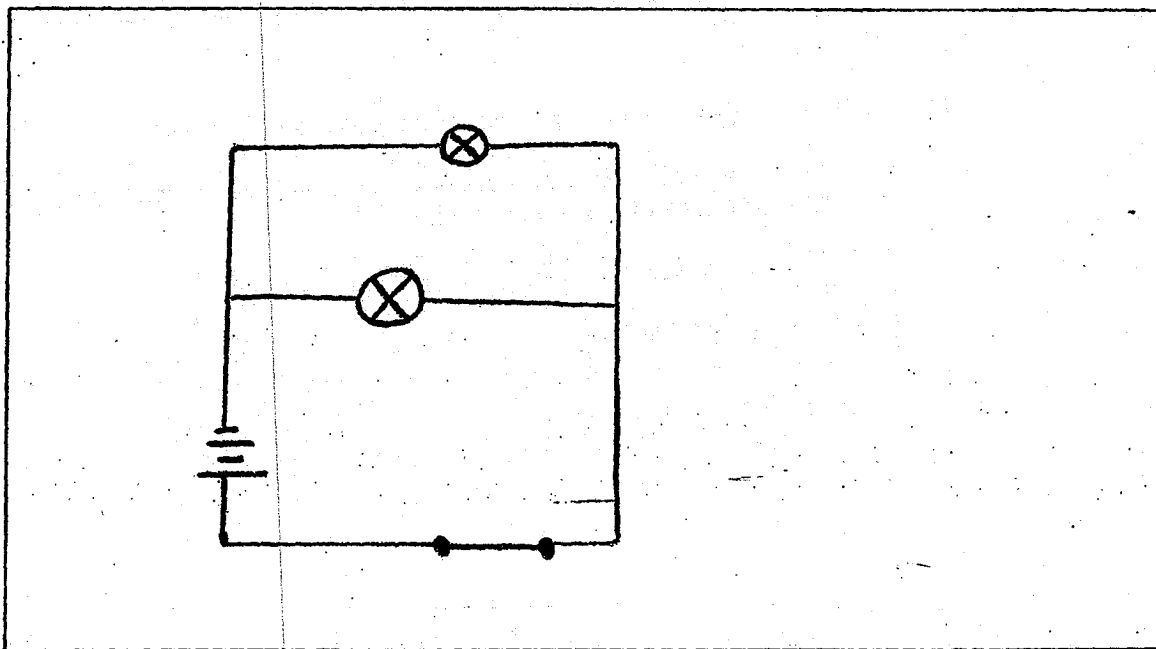

- (b) Glenda added more batteries to the circuit and realised that both bulbs fused. Explain why the bulbs would not light up after they had fused. [1]



38. Tim conducted an experiment to find a suitable material to paste over his bathroom window so that no one could see through the window,

He set up the experiment in a dark room as shown below.

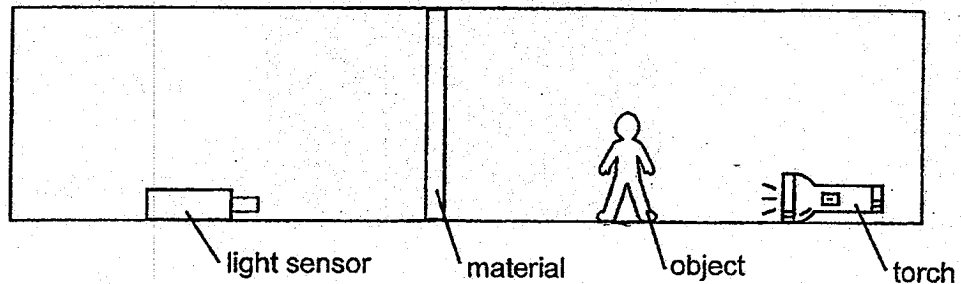

The table below shows the results of his experiment.

Set-up	Material	Amount of light detected (units)	Distance between light sensor and material (cm)
1	W	150	50
2	X	30	30
3	W	165	40
4	X	18	50

- (a) Based on the table above, which set-ups should Tim use to conduct his experiment? [1]

- (b) Which material is more suitable to be pasted over Tim's bathroom window? Explain your answer. [2]

The material selected is still not suitable as Tim could see a faint image through the bathroom window.

- (c) State the property of the material that would be more suitable to be pasted over the bathroom window. [1]

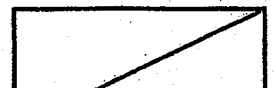

39. Emily made a glitter-in-a-bottle toy by filling a glass bottle to the brim with liquid X and sealed it tightly with a lid as shown in the diagram below.

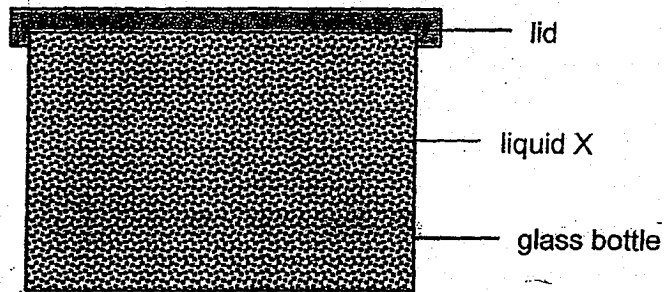

Emily left the toy under the sun for half a day and found that some liquid X had leaked out of the bottle.

- (a) Explain why liquid X leaked out of the bottle. [2]

One way to prevent liquid X from leaking out is to leave an air space in the bottle as shown below.

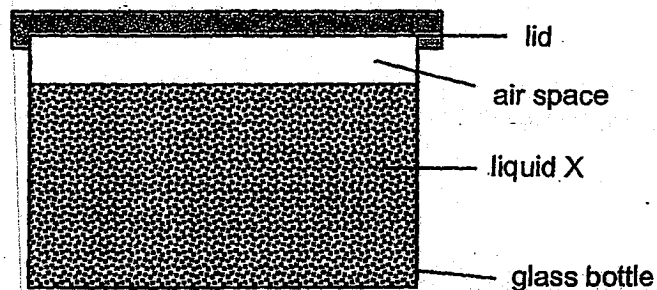

- (b) Explain how the air space could prevent liquid X from seeping out of the bottle. [2]



40. Eddie used the set-up shown below to investigate the effect of magnetic forces.

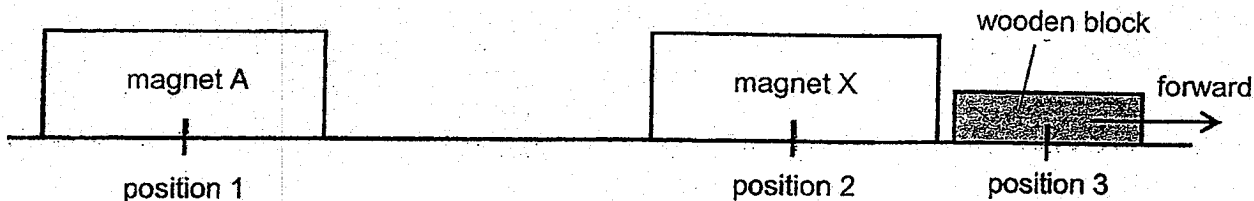

Eddie observed that when he placed magnet A at position 1, magnet X moved forward, pushing the wooden block forward as well. He recorded the distance travelled by the wooden block.

- (a) Explain how magnet A was able to cause the wooden block to move forward. [1]

He repeated the experiment by placing magnets B, C and D at position 1, one at a time. He then recorded his results as shown in the table below.

Magnet	Distance travelled by the wooden block (cm)
A	5
B	8
C	3
D	0

- (b) Which magnet, A, B, or C, has the strongest magnetism? Explain your answer. [2]

- (c) Give one possible reason why when magnet D was placed at position 1, the distance travelled by the wooden block was 0 cm. [1]



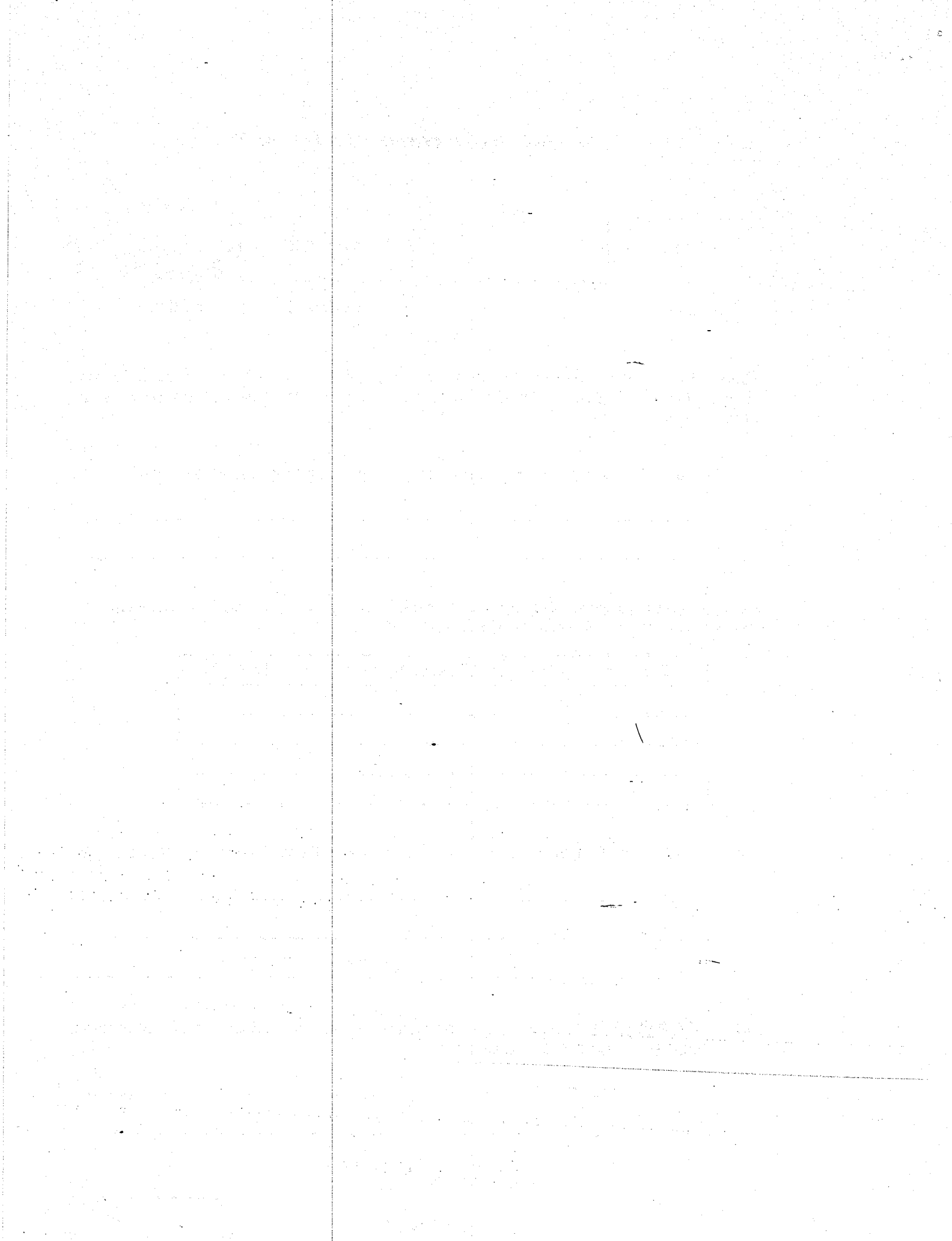

P6 SCIENCE Prelim 2019

Suggested Answers

Section A

1	1	11	1	21	2
2	4	12	1	22	1
3	4	13	3	23	2
4	2	14	4	24	4
5	3	15	1	25	2
6	4	16	4	26	1
7	3	17	3	27	1
8	4	18	2	28	2
9	4	19	4		
10	1	20	1		

Section B

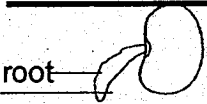
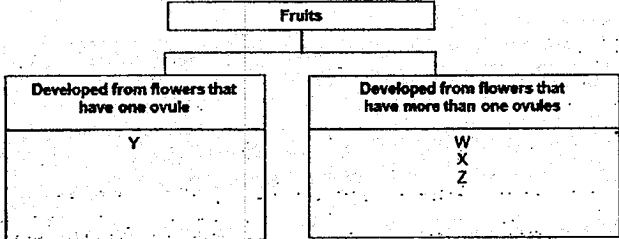
Qn No	Acceptable Answers								
29(a).	At 10 plants and below, the height of the plants remains constant. Above 10 plants, the greater the number of plants grown, the greater the height of the plants.								
29(b).	The seedlings have to compete for space, light, water and nutrients/mineral salts.								
29(c).	The rainfall in Sep was the least so the seeds did not have (enough) water to germinate.								
29(d).									
30(a).	U → S → T								
30(b).	Circle the letter B								
30(c).	There will be less T to feed on S. There will be more S to feed on U.								
31(a).	The greater the exposed surface area, the greater the amount of heat lost by the block.								
31(b).	Animal G can lose more heat (to the surrounding) which will help it to cool down.								
31(c).	The thick layer of hair traps air which is a poor conductor of heat. Thus, animal H will lose less heat to the surrounding which will help it to keep/ remain warm.								
32(a).									
32(bi).	Evan is wrong because part P has seeds hence it is a fruit, and since fruits develop from flowering plants/ flowers.								
32(bii).	Fion is wrong because part P is juicy/red hence it is more likely to be dispersed by animals.								
33(a).	The digested food is absorbed into the bloodstream. The circulatory system will then transports the digested food to all parts of the body.								
33(b).	<table border="1"> <thead> <tr> <th>Activity</th> <th>Period</th> </tr> </thead> <tbody> <tr> <td>Running</td> <td>C</td> </tr> <tr> <td>Reading</td> <td>B</td> </tr> <tr> <td>Sweeping</td> <td>A</td> </tr> </tbody> </table>	Activity	Period	Running	C	Reading	B	Sweeping	A
Activity	Period								
Running	C								
Reading	B								
Sweeping	A								
34(a).	Skeletal system								
34(b).	Both ensure that the body remain upright. or Both support his body/leg.								

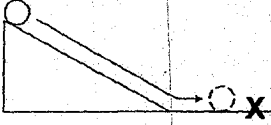
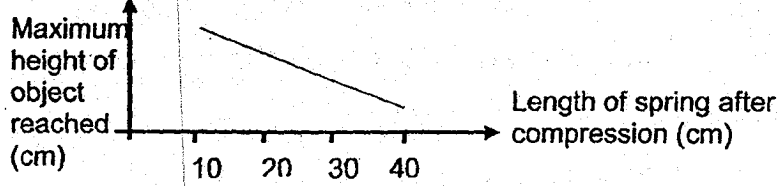
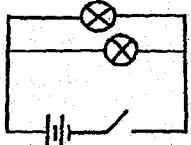
35(a).	<table border="1"> <thead> <tr> <th data-bbox="344 99 576 171">Types of Energy</th> <th data-bbox="576 99 724 171">Increase</th> <th data-bbox="724 99 888 171">Decrease</th> <th data-bbox="888 99 1163 171">Remains the same</th> </tr> </thead> <tbody> <tr> <td data-bbox="344 171 576 209">Potential energy</td> <td data-bbox="576 171 724 209"></td> <td data-bbox="724 171 888 209">√</td> <td data-bbox="888 171 1163 209"></td> </tr> <tr> <td data-bbox="344 209 576 246">Kinetic energy</td> <td data-bbox="576 209 724 246">√</td> <td data-bbox="724 209 888 246"></td> <td data-bbox="888 209 1163 246"></td> </tr> <tr> <td data-bbox="344 246 576 306">Heat energy</td> <td data-bbox="576 246 724 306">√</td> <td data-bbox="724 246 888 306"></td> <td data-bbox="888 246 1163 306"></td> </tr> </tbody> </table>	Types of Energy	Increase	Decrease	Remains the same	Potential energy		√		Kinetic energy	√			Heat energy	√		
Types of Energy	Increase	Decrease	Remains the same														
Potential energy		√															
Kinetic energy	√																
Heat energy	√																
35(b)(i).																	
35(b)(ii).	There will be less kinetic energy converted to heat energy so there will be more kinetic energy for the ball to move faster/ further.																
35(c).	PE → KE → KE → SE/ KE (write in full, not short forms ok?)																
36(a).																	
36(b).	The shoes allow the person to jump higher. When jumping with the shoes, there is elastic spring force of the spring (together with the push force of the legs), resulting in more force acting against gravitational force acting on the user.																
36(c).	More than 2m but less than 3m																
37(a).																	
37(b).	When the bulbs fused, there is an open circuit/ circuit is not closed and thus electricity can no longer flow through the bulbs to light up the bulb.																
38(a).	Set-ups 1 and 4.																
38(b).	Material X (material). There is less light detected by the sensor (data), so it allows less light to pass through (property), so no one could see clearly through the window (function).																
38(c).	It is opaque / allows no light to pass through/ does not allow light to pass through.																
39(a).	Liquid X will gain heat from the sun and expand, As there is no space for the liquid to occupy/ liquid cannot be compressed, the liquid seeped out (application) OR Liquid X and the glass bottle will gain heat from the sun and expand. As liquid X expands more than the bottle, there is no space for the liquid to occupy, thus the liquid seeped out.																
39(b).	When liquid X expands, it compresses the air in the air space and occupies the space previously occupied by the air/ liquid X displaces the air. Thus it does not leak out.																
40(a).	The like poles of magnet A and magnet X were facing each other, hence they repelled. Magnet X moved forward causing the wooden block to move forward as well.																
40(b).	Magnet B. When magnet B was placed at position 1, the distance travelled by the wooden block was the furthest this means that there was the greatest repulsion/ repel the furthest.																
40(c).	The unlike poles of magnet D and magnet X could be facing each other so both magnets would attract each other. Or The magnetism in magnet D was so weak/ demagnetised that it could not repel magnet X so magnet X did not move.																