

NAME: \_\_\_\_\_ ( )

CLASS: 4 ( )



**ANGLICAN HIGH SCHOOL  
SECONDARY FOUR  
PRELIMINARY EXAMINATIONS 2021**

S4

**MATHEMATICS****Paper 1**

Candidates answer on the Question Paper.

**4048****26 August 2021****2 hours****READ THESE INSTRUCTIONS FIRST**

Write your name, index number and class in the space at the top of this page.

Write in dark blue or black pen.

You may use a HB pencil for any diagrams or graphs.

Do not use staples, paper clips, highlighters and glue or correction fluid.

Answer **all** the questions.

If working is needed for any question it must be shown with the answer.

Omission of essential working will result in loss of marks.

The use of an approved scientific calculator is expected, where appropriate.

If the degree of accuracy is not specified in the question, and if the answer is not exact, give the answer to three significant figures. Give answers in degrees to one decimal place.

For  $\pi$ , use either your calculator value or 3.142, unless the question requires the answer in terms of  $\pi$ .

The number of marks is given in brackets [ ] at the end of each question or part question.

The total number of marks for this paper is 80.

**For Examiners' Use**

Question	1	2	3	4	5	6	7	8	9
Marks									
Question	10	11	12	13	14	15	16	17	18
Marks									
Question	19	20	21	22	23	24	25		
Marks									
Table of Penalties			Units		Clarity / Logic		Precision / Accuracy		
Parent's Name and Signature									
			Total						
Date:									

This document consists of 19 printed pages.

**Mathematical Formulae****Compound Interest**

$$\text{Total amount} = P \left( 1 + \frac{r}{100} \right)^n$$

**Mensuration**

$$\text{Curved surface area of a cone} = \pi r l$$

$$\text{Surface area of a sphere} = 4\pi r^2$$

$$\text{Volume of a cone} = \frac{1}{3} \pi r^2 h$$

$$\text{Volume of a sphere} = \frac{4}{3} \pi r^3$$

$$\text{Area of triangle } ABC = \frac{1}{2} ab \sin C$$

$$\text{Arc length} = r\theta, \text{ where } \theta \text{ is in radians}$$

$$\text{Sector area} = \frac{1}{2} r^2 \theta, \text{ where } \theta \text{ is in radians}$$

**Trigonometry**

$$\frac{a}{\sin A} = \frac{b}{\sin B} = \frac{c}{\sin C}$$

$$a^2 = b^2 + c^2 - 2bc \cos A$$

**Statistics**

$$\text{Mean} = \frac{\sum fx}{\sum f}$$

$$\text{Standard deviation} = \sqrt{\frac{\sum fx^2}{\sum f} - \left( \frac{\sum fx}{\sum f} \right)^2}$$

1(a) Given that  $3^{27} \div 27^3 = 3^k$ , find  $k$ .

Answer  $k =$  \_\_\_\_\_ [1]

(b) Simplify  $\frac{4x^{-4}}{-4} \times \frac{y^{\frac{2}{3}}}{18} \div \frac{1}{27}$ , leaving your answers in positive indices.

Answer \_\_\_\_\_ [2]

2 The curve below has an equation  $y = x^n + c$ . State a possible value of  $n$  and the value of  $c$ .

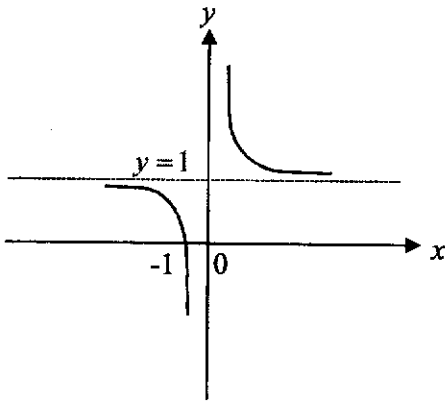

Answer  $n =$  \_\_\_\_\_

$c =$  \_\_\_\_\_ [2]

3. Jasmin has 240 two-centimetre cubes. She arranges all of the cubes into a cuboid. The perimeter of the base of the cuboid is 40 cm. Each side of the cuboid has a length greater than 4 cm. Find the height of the cuboid.

Answer \_\_\_\_\_ cm [2]

4. Violet intends to arrange  $n$  regular pentagons in a ring. The diagram shows the partially completed ring. Find  $n$ .

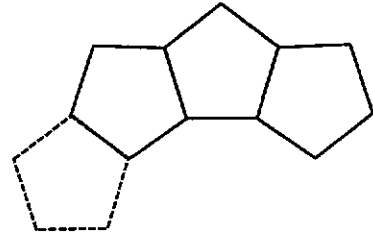

Answer  $n =$  \_\_\_\_\_ [3]

5 The bar chart shows the number of traffic accidents resulting in injury from 2014 to 2018. (<https://www.budgetdirect.com.sg/car-insurance/research/road-accident-statistics-in-singapore>)

**Number of Accidents Resulting in Injuries (2014 – 2018)**

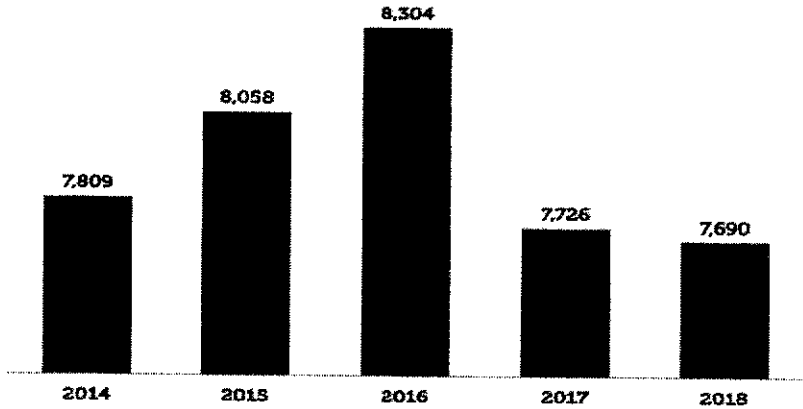

State how this bar chart can be misleading to the reader.

[1]

6 (a) Given that

$$\zeta = \{\text{all triangles}\}$$

$$R = \{\text{right-angled triangles}\}$$

$$S = \{\text{triangles with three unequal sides}\}$$

$A$  is a triangle with  $45^\circ$ ,  $45^\circ$  and  $90^\circ$ .

$B$  is a triangle with 7 cm, 7 cm and 3 cm.

$C$  is a triangle with sides 9 cm, 12 cm and 15 cm.

Represent the above information on a Venn Diagram in the space below.

[2]

(b) Write down the sets represented by the following shaded region

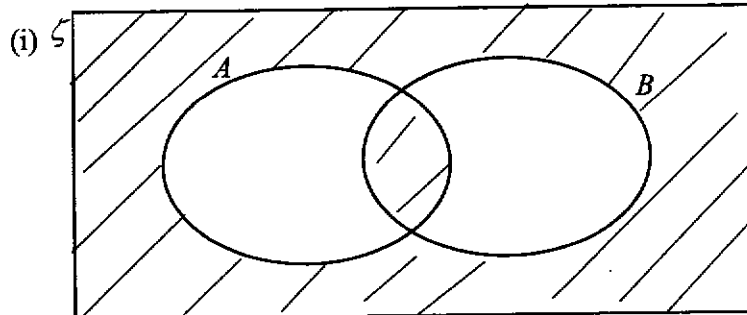

*Answer*

[1]

7 The speed of light is  $3 \times 10^8$  m/s. Earth is 150 million km from the sun. How long does light take to travel from the sun to the earth. Round your answer to the nearest minute.

*Answer* \_\_\_\_\_ minutes [2]

- 8 A maximum quadratic curve with the equation  $y = -x^2 + bx + c$  has a turning point at  $(3, 7)$ , find the value of  $b$  and of  $c$ .

9 Solve the equation  $\frac{1}{x+1} - \frac{6x^2 - 10}{1 - x^2} = 4$ .

*Answer*  $x =$  \_\_\_\_\_ or  $x =$  \_\_\_\_\_ [4]

10 Simplify  $\frac{27 - 12x^2}{-3 - 2x^2 + 5x} \times \frac{1 - x}{-2x - 3}$ .

Answer \_\_\_\_\_ [3]

- 11 In the diagram below,  $XZ$  is the chord of a circle.  $XY$  is the diameter of the circle, centre  $O$ .  
Given that  $XZ = 9$  cm and  $YZ = \sqrt{63}$  cm, calculate

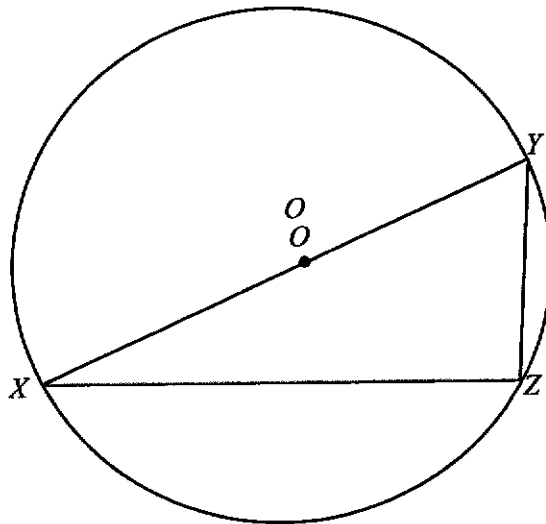

- (a) the length of  $XY$ ,

Answer  $XY =$  \_\_\_\_\_ [1]

- (b)  $\angle YXZ$ ,

Answer  $\angle YXZ =$  \_\_\_\_\_  $^\circ$  [1]



(c)  $\angle YOZ$  in radian,

*Answer*  $\angle YOZ =$  \_\_\_\_\_ rad [2]

(d) the area of the major segment  $YZ$ .

*Answer* = \_\_\_\_\_  $\text{cm}^2$  [3]

12

$y = x^3 - 4$	$y = -3(4)^x$	$y = 4 - x^2$	$y = 4x^{-2}$
$y = -2x^{-4}$	$y = 4 - x^3$	$y = -3(-4)^x$	$y = x^2 + 4$

Write down a possible equation for each of the sketch graphs below.  
In each case select one of the equations from the box above.

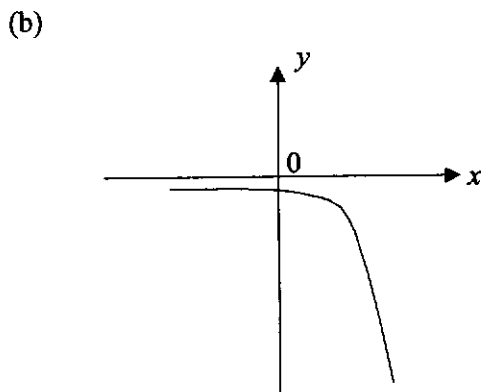
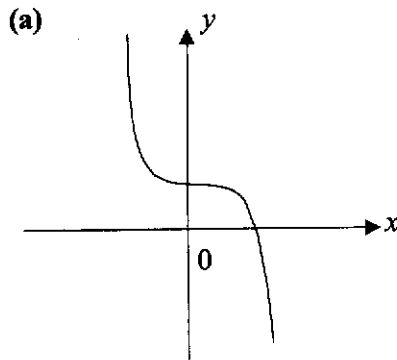

- 13 Make  $x$  the subject in the equation  $y = \sqrt{x^2 - 8x + 16} - y^2$ .

Answer \_\_\_\_\_ [3]

- 14 In the diagram shown below, it is given that  $AP = 5$  cm,  $BP = 2$  cm and  $AR = 3$  cm.  $ARC$ ,  $ABP$  and  $RQP$  are straight lines. Show, with clear reasons, that triangle  $ABC$  is congruent to triangle  $ARP$ .

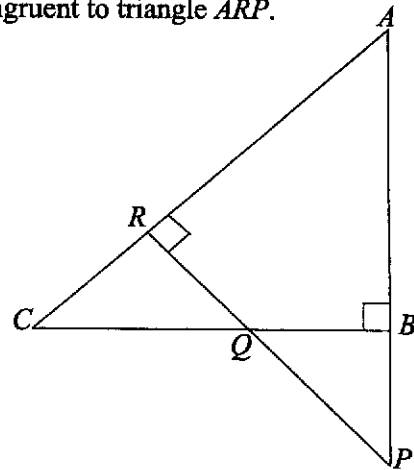

[2]

- 15 A lake has an actual area of  $2.5 \text{ km}^2$ . The area of the lake on the map is  $40 \text{ cm}^2$ . The distance between two towns on the map is  $45 \text{ cm}$ . Find the actual distance, in kilometres, between the two towns.

16 (a) Solve the inequalities  $\frac{8x-12}{2} \leq 3x+1 < \frac{17x}{3}$ .

Answer \_\_\_\_\_ km [3]

Answer \_\_\_\_\_ [3]

(b) Hence, write down all the prime numbers that satisfy  $\frac{8x-12}{2} \leq 3x+1 < \frac{17x}{3}$ .

Answer \_\_\_\_\_ [1]

17 Factorise completely  $4x^2 - 12xy + 9y^2 - 1$ .

Answer \_\_\_\_\_ [2]

18 The Venn diagram shows the elements of  $\xi$  and three sets  $A$ ,  $B$  and  $C$ .  
 $\xi = \{x: x \text{ is a positive integer such that } 0 < x < 14\}$

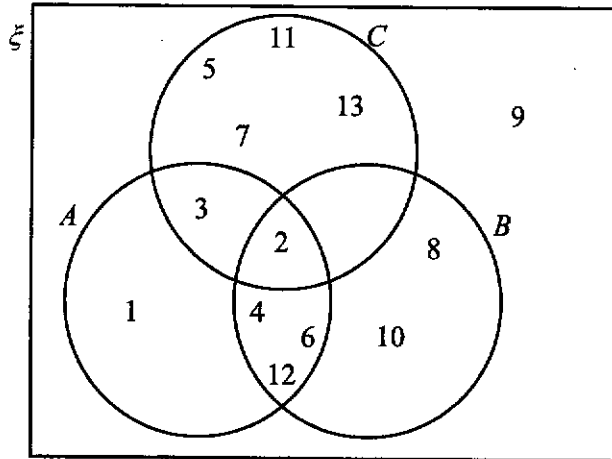

(a) Describe in words the elements in set  $C$ .

(b) Use one of the symbols below to complete each statement.

$$\emptyset \subset \subsetneq \notin \in \xi$$

(i)  $A' \cap (B \cap C) = \dots\dots\dots$

(ii)  $3 \dots\dots\dots A$

- 19 The time taken to assemble a car is inversely proportional to the number of workers involved. 4 workers can complete the assembly in  $x$  days. If 6 more workers are involved, the assembly can be completed 3 days in advance.
- (a) Find the value of  $x$ .

Answer  $x =$  \_\_\_\_\_ [2]

- (b) Find the number of workers required if the assembly is to be completed in 2 days.

Answer \_\_\_\_\_ [2]

- 20 In the figure,  $ABCD$  is a quadrilateral. The point  $X$  is such that  $XB$  and  $XD$  are the angle bisectors of angle  $ABC$  and angle  $ADC$  respectively.  
 Reflex angle  $BCD = 200^\circ$  and reflex angle  $BXD = 225^\circ$ .  
 Calculate angle  $BAD$ .

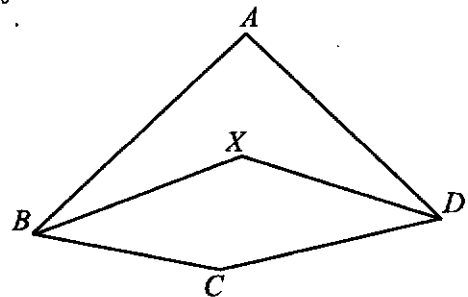

Answer \_\_\_\_\_ [4]

- 21 (a) An open container in a shape of an inverted cone has radius of 10 cm and height of 30 cm. Water is poured into the container at a constant rate of  $5\pi \text{ cm}^3/\text{s}$  until it is completely filled to the brim.  
Find the time taken for the container to be completely filled.

Answer \_\_\_\_\_ s [1]

- (b) Sketch the graph of the water-level against time below.  
Height (cm)

[1]

- 22 A popular drink is produced in two similar bottle sizes. The height of the large bottle *A* is 18 cm while the height of the smaller bottle *B* is 12 cm.

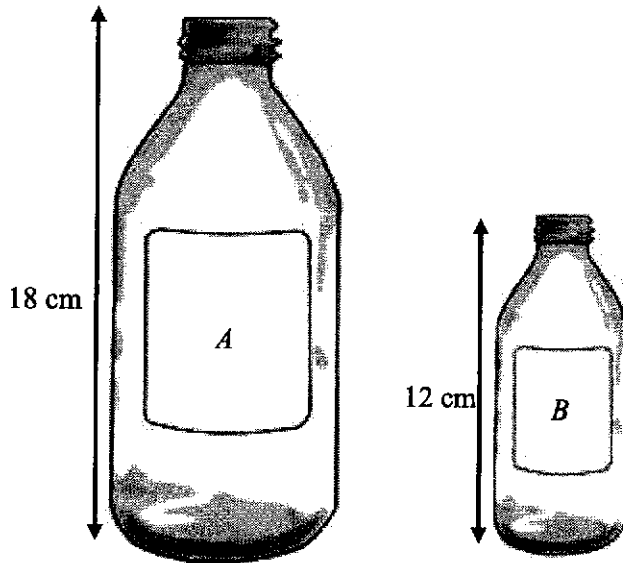

If the selling prices of bottles *A* and *B* are \$24.90 and \$6.90 respectively, which bottle provides better value for money? Justify your answer clearly. [3]

- 23 The cumulative frequency diagram shows the times taken by 200 girls from school *A* running 2.4 km test. The box-and-whisker plot shows the times for another group of girls from school *B*.

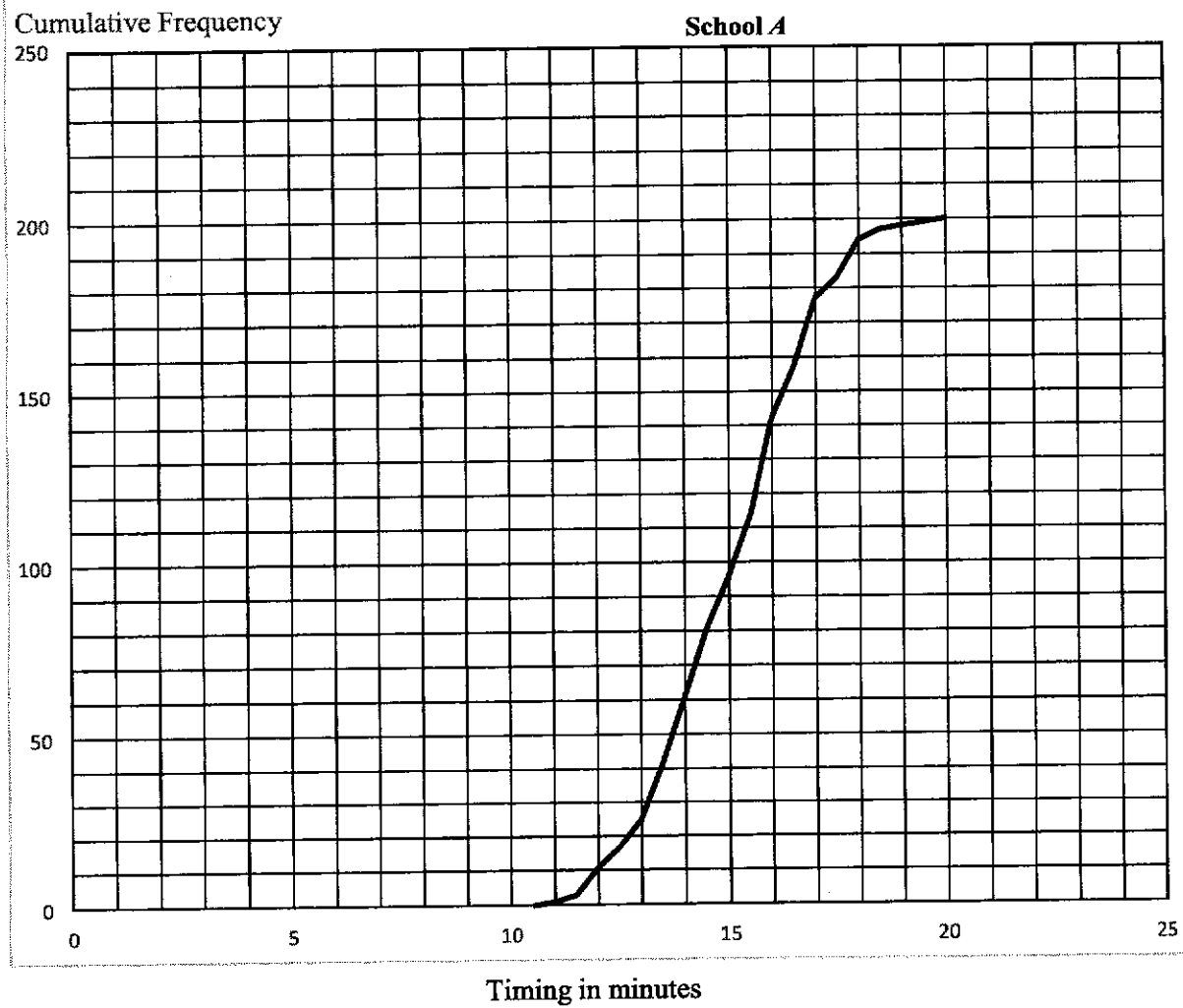



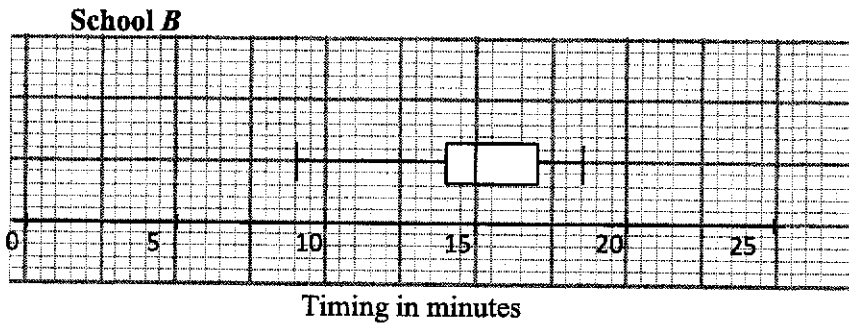

- (a) 75% of the girls in school B failed the test. Find the number of girls who passed in school A.

*Answer*..... [1]

- (b) 30% of the girls in school A took longer than  $t$  minutes. Find  $t$ . [2]

*Answer*..... [2]

- (c) Find the proportion of girls in school A who took between 14.5 minutes and 17 minutes to complete the run.

*Answer*..... [2]

- 24 (a) Construct kite  $ABCD$ .  $AD = CD = 9$  cm.  $AB$  and  $BC$  have already been drawn. Measure and state the length of the longest diagonal.

*Answer*

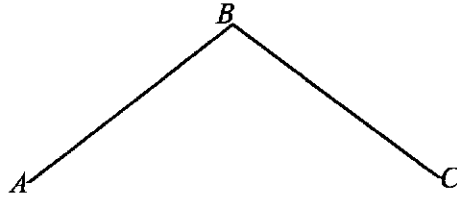

- (b) Construct the perpendicular bisector  $BC$ . [1]  
 (c) Construct the bisector of the angle  $ABC$ . [1]
- (d)  $ABCD$  represents a plot of land which is to be used for a park. A café is to be built in park, nearer to  $A$  than to  $D$  and nearer to  $AD$  than  $AB$ . Shade the region where the café is to be built.

25 Ahmad and Beng Hai want to rent lockers in school. The lockers are in two levels. Lockers 1A to 1C are on the lower level and Lockers 2A to 2C are on the next level. Lockers are assigned to each student randomly.

- (e) Using a possibility diagram, represent the two lockers that the two boys can be allocated such that they are next to each other on the same level.

[2]

- (b) Find the probability that Ahmad and Beng Hai are randomly allocated lockers next to each other on Level 2.

*Answer* \_\_\_\_\_ [1]

- (c) Find the probability that Ahmad and Beng Hai are randomly allocated lockers on different levels.

*Answer* \_\_\_\_\_ [1]

- (d) If the lockers 2C was not available. Find the probability that the friends will be allocated lockers next to each other at any level.

*Answer* \_\_\_\_\_ [2]

**End of paper**

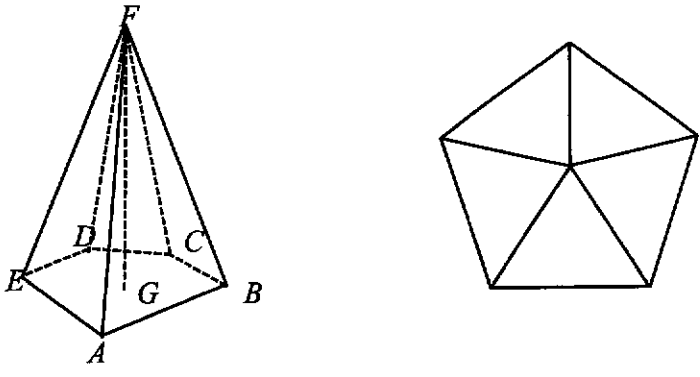
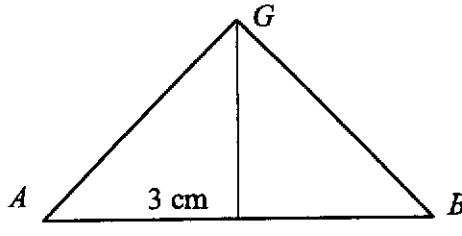

Qn		
1	A sequence is given by the formula $P_{n+1} = (P_n)^2 + mP_n$ , where $m$ is a constant.	
1a	Given that $P_1 = 3$ , show that $P_2 = 3m + 9$ .	
1b	Given that $P_2 = -\frac{3}{4}$ , find the value of $m$ ,	
1ci	By using the answer in (b), find $P_3, P_4$ and $P_5$ .	
1cii	By considering the terms of $P_1, P_2, P_3, P_4$ and $P_5$ or otherwise, find the value of $P_{2016}$ .	

2a	<p>The diagram shows a pyramid <math>ABCDEF</math>. The base of the pyramid is a regular pentagon of side 6 cm. The tip <math>F</math> is vertically above the centre of the pentagon, <math>G</math>, and <math>AF = 14</math> cm. Calculate the angle <math>AGB</math>.</p> 	
2b	<p>Show that <math>AG = 5.1039</math> cm, correct to five significant figures.</p>	[2]
		
2c	<p>Calculate the height of the pyramid, <math>FG</math>.</p>	[2]
2d	<p>The pyramid is the model for a paper weight that is to be gold plated. To reduce costs the pyramid is made smaller such that the smaller pyramid remains geometrically similar to the original pyramid but its height is reduced by 35%.</p> <p>The surface area of the large pyramid is <math>S</math> cm<sup>3</sup>. Express the surface area of the new pyramid as a percentage of <math>S</math>.</p>	[3]

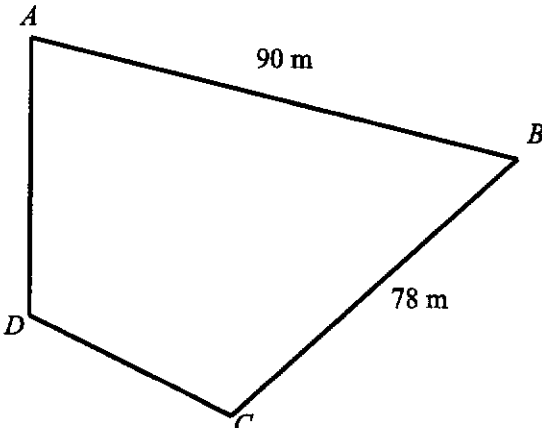
3i	<p>Given that the points <math>P(3, k)</math>, <math>Q(1, -2)</math> and <math>R(-4, -6k)</math> lie on a straight line, find the value of <math>k</math>.</p> <p>Gradient of <math>AB =</math> Gradient of <math>AC</math></p>	
3ii	<p>Find the length of the line segment <math>PQ</math>.</p>	
4	<p>Quadrilateral <math>ABCD</math> is a field with <math>AB = 90</math> m and <math>BC = 78</math> m and <math>A</math> is due north of <math>D</math>. The bearing of <math>B</math> from <math>A</math> is <math>100^\circ</math>, the bearing of <math>B</math> from <math>C</math> is <math>025^\circ</math> and the bearing of <math>D</math> from <math>C</math> is <math>278^\circ</math>.</p>  <p>The diagram shows a quadrilateral ABCD. Vertex A is at the top left, B is at the top right, C is at the bottom right, and D is at the bottom left. Side AB is labeled 90 m and side BC is labeled 78 m. A vertical line segment connects A and D, indicating they are due north-south of each other.</p>	

<b>4ai</b>	Show that angle $ABC = 75^\circ$ .	
<b>4aii</b>	Calculate the bearing of $C$ from $D$ ,	
<b>4aii</b>	Calculate the length of $AC$ .	
<b>4bi</b>	A drone hovers at a height of 70 m above $D$ . A man of height 1.75m walks along path $AC$ . He stopped at $E$ to take a picture of the drone when the maximum angle of depression from the drone to the top of the man's head was $58^\circ$ . Calculate the length of $DE$ .	
<b>4bii</b>	Calculate the area of the field $ABCD$ .	
<b>5</b>	Adam runs a drink stall franchise in 4 locations. The number of cups for each type of drink sold a day is shown in the table below.	



5a	Represent the above information as a $4 \times 3$ matrix <b>P</b> .	[1]								
5b	<p>The price of drinks are shown in the table below.</p> <table border="1" data-bbox="395 792 1064 949"> <thead> <tr> <th>Drink</th> <th>Price (SGD\$)</th> </tr> </thead> <tbody> <tr> <td>Coffee</td> <td>1.50</td> </tr> <tr> <td>Tea</td> <td>1</td> </tr> <tr> <td>Fruit Juice</td> <td>2</td> </tr> </tbody> </table> <p>Represent the above information as a <math>3 \times 1</math> matrix <b>N</b>.</p>	Drink	Price (SGD\$)	Coffee	1.50	Tea	1	Fruit Juice	2	
Drink	Price (SGD\$)									
Coffee	1.50									
Tea	1									
Fruit Juice	2									
5c	Evaluate the matrix <b>T = PN</b> .	[1]								
5d	State what each of the elements of matrix <b>T</b> represents.									

- 5ei The cost of all the ingredients per day for Branch *A*, *B*, *C* and *D* is shown in the table below. [2]

Branch	All ingredients for drinks	
	In USD	In SGD
<i>A</i>	$p$	27
<i>B</i>	12	16.20
<i>C</i>	16	21.60
<i>D</i>	23	$q$

Find the value of  $p$  and  $q$ .

- 5eii The rental and operating cost per day for Branch *A*, *B*, *C* and *D* is shown in the table below. [2]

Branch	Rental & Operating Cost (SGD)
<i>A</i>	40
<i>B</i>	45
<i>C</i>	50
<i>D</i>	60

<b>6</b>	44 boys ran the 2.4 km and their timings are shown in the table.						
	$t$ (minutes)	$8 \leq t < 9$	$9 \leq t < 10$	$10 \leq t < 11$	$11 \leq t < 12$	$12 \leq t < 13$	$13 \leq t < 14$
	Frequency	1	$h$	12	11	$k$	6
<b>6a</b>	The estimated mean timing is 11.477 minutes. Estimate to the nearest integer the value of $h$ and the value of $k$ .					[4]	
<b>6b</b>	Estimate the standard deviation.					[1]	
<b>6c</b>	Explain why in this case, the mean is better than the median as a measure of central tendency.					[1]	
<b>6d</b>	Another group of 35 boys ran the 2.4 km and their mean and standard deviation were 11.7 minutes and 2.10 minutes respectively. Comment on the timings of these two groups of boys.					[2]	
<b>7</b>	It is given that point $A$ lies on the $y$ -axis while point $B$ lies on the $x$ -axis such that $OB = 2OA$ , where $O$ is the origin. given that the line $AB$ passes through the point					[3]	

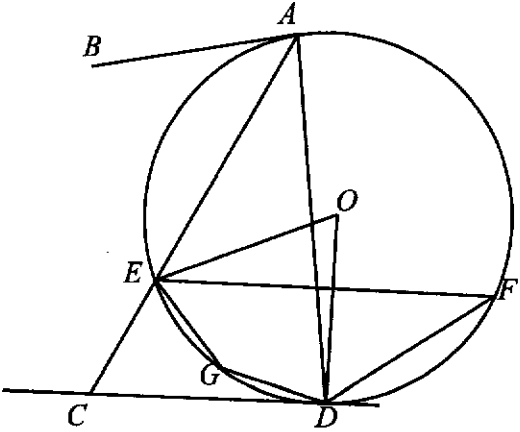
8	<p>In the diagram, line <math>AB</math> and line <math>CD</math> are tangents to point <math>A</math> and point <math>D</math> respectively on the circumference of the circle with centre <math>O</math>. Angle <math>DAE = 33^\circ</math>, angle <math>ECD = 59^\circ</math> and <math>AEC</math> is a straight line. <math>E</math>, <math>F</math>, and <math>G</math> are points on the circumference of the circle.</p> 	
8a	Find angle $EOD$ .	[1]
8b	Find angle $EFD$	
8c	Find angle $EGD$	
8d	A circle is drawn with the line $AC$ as its diameter. Explain why point $D$ will not lie on the circumference of the circle.	[2]

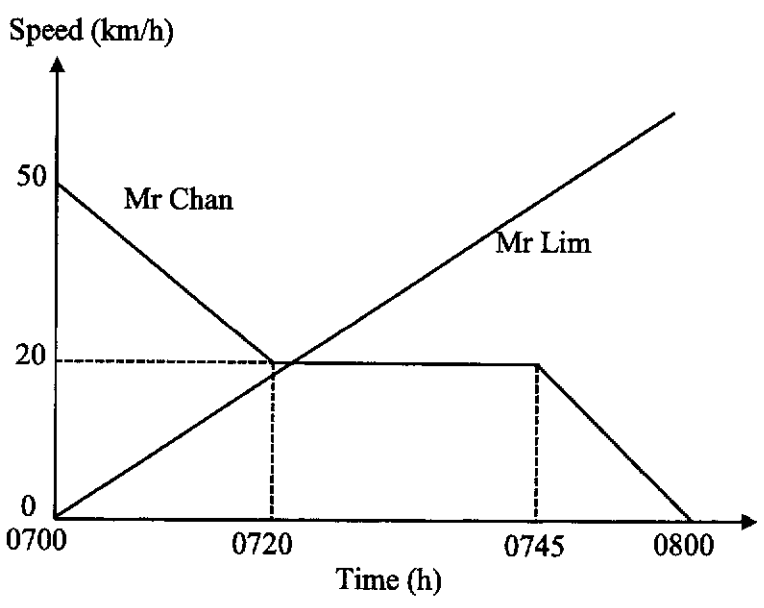
8e	Line $AB$ and $CD$ are extended and meet at $T$ . Find the angle $ATD$ .	
9	<p>Mr Chan driving a car at 50 km/h passes a lamppost A and stops at lamppost B, one hour later. When Mr Chan passes the lamppost A, Mr Lim, on a motorcycle, starts from A and overtakes Mr Chan. The motorcycle has uniform acceleration of <math>80 \text{ km/h}^2</math>. The speed-time graphs of Mr Chan and Mr Lim are shown in the diagram.</p> 	
9ai	Find the speed of the car at 0715 h.	[2]

<b>9ai</b> <b>i</b>	Find the speed of the motorcycle at 0745 h.	[1]
<b>9ai</b> <b>ii</b>	Find the time, to the nearest minute, the motorcycle overtakes the car, given that it was between 0720 h and 0745 h	[4]
	Let $t$ minutes be the time taken by Mr. Lim to overtake Mr. Chan	

9b Sketch the acceleration time graph for Mr. Chan.

[2]

- 10 The diagram below shows a rectangle with breadth  $(x+15)$  cm. The circle with centre at  $A$  has a radius of 10 cm. The semicircle with centre at  $B$  and the semicircle with centre  $C$  are congruent and each has a radius of  $x$  cm. The small circle with centre  $A$  touches the semicircles at point  $D$  and  $E$ . The line  $AO$  bisects the length of the rectangle and is a tangent to both of the semicircles.

<b>10a</b>	Write down an expression, in terms of $x$ , for the length $AC$ .	[1]
<b>10b</b>	Write down an expression, in terms of $x$ , for the length $OA$ .	[1]
<b>10c</b>	Hence, write down an equation and show that it simplifies to $x^2 - 10x - 75 = 0$ .	[3]
<b>10d</b>	Solve the equation $x^2 - 10x - 75 = 0$ .	[2]
<b>10e</b>	Hence, find the shaded area.	[2]
<b>11</b>	A couple intends to purchase a HDB flat and they intend to take a loan from a financial institution. The formula to calculate the monthly mortgage payment is given by	



<p><b>11 a</b></p>	<p>If the couple takes a \$100000 loan to be repaid in 10 years, find the total interest paid as a percentage of the loan, assuming an interest rate of 2% per annum.</p>	<p>[3]</p>								
<p><b>11 b</b></p>	<p>The couple intends to take a loan from a financial institution. so they will need to pay 25% of the price as down payment. For the down-payment, they intend to pay up to \$50000.</p> <p>An online search yielded information in the tables below.</p> <p style="text-align: center;"><b>2021 Property Prices in Singapore</b></p> <table border="1" data-bbox="316 1659 1114 1926"> <thead> <tr> <th>Type</th> <th>HDB BTO Flats (Non-Mature Estates)</th> <th>HDB BTO Flats (Mature Estates)</th> <th>Resale Flats</th> </tr> </thead> <tbody> <tr> <td>Two-Room (Flexi)</td> <td>\$90,000 to \$162,000</td> <td>\$137,000 to \$277,000</td> <td>–</td> </tr> </tbody> </table>	Type	HDB BTO Flats (Non-Mature Estates)	HDB BTO Flats (Mature Estates)	Resale Flats	Two-Room (Flexi)	\$90,000 to \$162,000	\$137,000 to \$277,000	–	<p>[3]</p>
Type	HDB BTO Flats (Non-Mature Estates)	HDB BTO Flats (Mature Estates)	Resale Flats							
Two-Room (Flexi)	\$90,000 to \$162,000	\$137,000 to \$277,000	–							

The couple intends to take a loan from a financial institution, so they will need to pay 25% of the price as down-payment. For the down-payment, they intend to pay up to \$50000.

An online search yielded information in the tables below.

2021 Property Prices in Singapore

Type	HDB BTO Flats (Non-Mature Estates)	HDB BTO Flats (Mature Estates)	Resale Flats
Two-Room (Flexi)	\$90,000 to \$162,000	\$137,000 to \$277,000	-
Three-Room	\$164,000 to \$248,000	\$205,000 to \$421,000	\$350,000 to \$380,000
Four-Room	\$253,000 to \$381,000	\$311,000 to \$617,000	\$420,000 to \$550,000
Five-Room	\$405,000 to \$516,000	\$423,000 to \$725,000	\$520,000 to \$700,000

Source: <https://www.singapore.com.sg/blog/costs-of-bto-flat-resale-flat-ec-and-condo-in-singapore>

HDB Flat Types	2-Room Flexi	3-Room	4-Room	5-Room
Approx. floor area (square metres)	36 and 45	60 to 65	90	110
Total no. of bedrooms	1	2	3	3
Total no. of bathrooms	1	2	2	2

(Source: <https://www.hdb.gov.sg/residential/buying-a-flat/resale/getting-started/types-of-flats>)

- (b) Determine all the types of flats that the couple can consider purchasing.

*Answer*

Three-Room	\$164,000 to \$248,000	\$205,000 to \$421,000	\$350,000 to \$380,000
Four-Room	\$253,000 to \$381,000	\$311,000 to \$617,000	\$420,000 to \$550,000
Five-Room	\$405,000 to \$516,000	\$423,000 to \$725,000	\$520,000 to \$700,000

Source: <https://www.singsaver.com.sg/blog/costs-of-bto-flat-resale-flat-ec-and-condo-in-singapore>



(Source: <https://www.hdb.gov.sg/residential/buying-a-flat/resale/getting-started/types-of-flats>)  
Determine all the types of flats that the couple can consider purchasing.

- 11c** | Based on the information given in the tables only, give the type of flat that gives the best value for the money spent. State one assumption that the couple could have made. | [3]

	Based on the price per sq m criterion, the first choice is a HDB BT Flats (Non-Mature Estates) Two-Room (Flexi) 45 sq m in the lower price range.															
	<p>Assumption, only one is needed:</p> <ol style="list-style-type: none"> <li>The prices of the different types of housing remains stable regardless of region.</li> <li>All the different types of flats are available.</li> <li>Without detailed information, the couple assumes that for each floor area, there can be the full range of prices, e.g. for a 45 m<sup>2</sup> flat, the prices can range from \$90,000 to \$162,000.</li> <li>Without detailed information, either the range of minimum to maximum, or the midpoint can be used for calculation.</li> </ol> <p>In each category, the lowest price corresponds to the smallest floor area, and the higher price corresponds to the larger floor area.</p>															
12	<p>The variables of <math>x</math> and <math>y</math> are connected by the equation</p> $y = \frac{x^2}{6} + \frac{2}{x} - 3.$ <p>Some corresponding values of <math>x</math> and <math>y</math>, correct to two decimal places, are given in the table below.</p> <table border="1"> <tr> <td><math>x</math></td> <td>0.5</td> <td>1</td> <td>1.5</td> <td>2</td> <td>2.5</td> <td>3</td> </tr> <tr> <td><math>y</math></td> <td><math>p</math></td> <td>-0.83</td> <td>-1.29</td> <td>-1.33</td> <td>-1.16</td> <td>-0.83</td> </tr> </table>	$x$	0.5	1	1.5	2	2.5	3	$y$	$p$	-0.83	-1.29	-1.33	-1.16	-0.83	
$x$	0.5	1	1.5	2	2.5	3										
$y$	$p$	-0.83	-1.29	-1.33	-1.16	-0.83										
12 a	Find the value of $p$ .	[1]														
12 b	<p>Use a scale of 2 cm to represent 1 unit, draw a horizontal <math>x</math>-axis from <math>0 \leq x \leq 6</math>. Use a scale of 4 cm to represent 1 unit, draw a vertical <math>y</math>-axis from <math>-2 \leq y \leq 4</math>.</p> <p>On your axes, plot the points given in the table and join them with a smooth curve.</p>	[3]														

<b>12c</b>	Use your graph to find the solutions of $\frac{x^2}{6} + \frac{2}{x} - 2 = 0$ .	[2]
<b>12d</b>	By drawing a tangent, find the gradient of the curve at $(3, -0.83)$ .	[2]
<b>12e i</b>	On the same axes, draw the line of with gradient $-0.5$ that passes through the point with coordinates $(4, -1)$ .	[1]

<b>12e ii</b>	Write down the equation of this line.	[1]
<b>12e iii</b>	Write down the $x$ -coordinates of the points where the line intersects the curve.	[2]
<b>12e iv</b>	These values of $x$ are the solutions of the equation $x^3 + Ax^2 - 24x + B = 0$ . Find the value of $A$ and of $B$ .	[2]





NAME: \_\_\_\_\_ ( )

CLASS: 4 ( )



**ANGLICAN HIGH SCHOOL  
SECONDARY FOUR  
PRELIMINARY EXAMINATIONS 2021**

S4

**MATHEMATICS****4048****Paper 1****26 August 2021**

Candidates answer on the Question Paper.

**2 hours****READ THESE INSTRUCTIONS FIRST****MARKING SCHEME**

Write your name, index number and class in the space at the top of this page.

Write in dark blue or black pen.

You may use a HB pencil for any diagrams or graphs.

Do not use staples, paper clips, highlighters and glue or correction fluid.

Answer **all** the questions.

If working is needed for any question it must be shown with the answer.

Omission of essential working will result in loss of marks.

The use of an approved scientific calculator is expected, where appropriate.

If the degree of accuracy is not specified in the question, and if the answer is not exact, give the answer to three significant figures. Give answers in degrees to one decimal place.

For  $\pi$ , use either your calculator value or 3.142, unless the question requires the answer in terms of  $\pi$ .

The number of marks is given in brackets [ ] at the end of each question or part question.

The total number of marks for this paper is 80.

**For Examiners' Use**

Question	1	2	3	4	5	6	7	8	9
Marks									
Question	10	11	12	13	14	15	16	17	18
Marks									
Question	19	20	21	22	23	24	25		
Marks									
Table of Penalties			Units		Clarity / Logic		Precision / Accuracy		
Parent's Name and Signature									
			Total		80				
Date:									

This document consists of 19 printed pages.

**Secondary Four Preliminary Mathematics Examination 2021****[Turn over**

**Mathematical Formulae****Compound Interest**

$$\text{Total amount} = P \left( 1 + \frac{r}{100} \right)^n$$

**Mensuration**

$$\text{Curved surface area of a cone} = \pi r l$$

$$\text{Surface area of a sphere} = 4\pi r^2$$

$$\text{Volume of a cone} = \frac{1}{3} \pi r^2 h$$

$$\text{Volume of a sphere} = \frac{4}{3} \pi r^3$$

$$\text{Area of triangle } ABC = \frac{1}{2} ab \sin C$$

$$\text{Arc length} = r\theta, \text{ where } \theta \text{ is in radians}$$

$$\text{Sector area} = \frac{1}{2} r^2 \theta, \text{ where } \theta \text{ is in radians}$$

**Trigonometry**

$$\frac{a}{\sin A} = \frac{b}{\sin B} = \frac{c}{\sin C}$$

$$a^2 = b^2 + c^2 - 2bc \cos A$$

**Statistics**

$$\text{Mean} = \frac{\sum fx}{\sum f}$$

$$\text{Standard deviation} = \sqrt{\frac{\sum fx^2}{\sum f} - \left( \frac{\sum fx}{\sum f} \right)^2}$$

1(a) Given that  $3^{27} \div 27^3 = 3^k$ , find  $k$ .

$$\begin{aligned} 3^{27} \div 3^9 &= 3^k \\ 3^{27-9} &= 3^k \\ k &= 18 \end{aligned}$$

Answer  $k =$  \_\_\_\_\_ [1]

(b) Simplify  $\frac{4x^{-4}}{-4} \times \frac{y^{\frac{2}{3}}}{18} \div \frac{1}{27}$ , leaving your answers in positive indices.

$$\begin{aligned} \frac{4y^{\frac{2}{3}}}{x^4} \times \frac{y^{\frac{2}{3}}}{18} \times 27 \\ = \frac{6y^{\frac{4}{3}}}{x^4} \\ = \frac{6y^2}{x^4} \end{aligned}$$

Answer \_\_\_\_\_ [2]

2 The curve below has an equation  $y = x^n + c$ . State a possible value of  $n$  and the value of  $c$ .

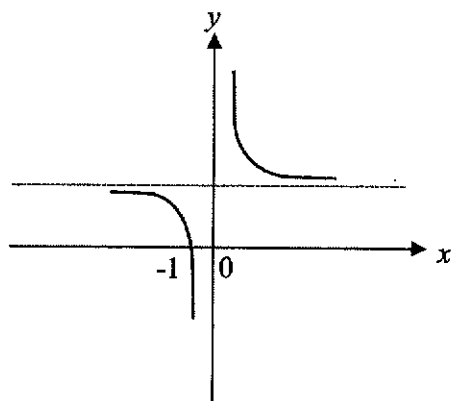

$$\begin{aligned} y &= x^n + c \\ n &= -1 \\ c &= 1 \end{aligned}$$

Answer  $n =$  \_\_\_\_\_

$c =$  \_\_\_\_\_ [2]

- 3 Jasmin has 240 two-centimetre cubes. She arranges all of the cubes into a cuboid. The perimeter of the base of the cuboid is 40 cm. Each side of the cuboid has a length greater than 4 cm. Find the height of the cuboid.

$$\begin{aligned} \text{Dimension of cuboid is } 2l \times 2b \times 2h &= 2^3 \times lbh \\ &= 2^3 \times 240 \end{aligned}$$

$$240 = 2^4 \times 3 \times 5$$

$$40 = 4l + 4b$$

$$10 = l + b$$

$$10 = 2 + 2^3 \text{ (rej)}, 10 = 2^2 + (2 \times 3)$$

$$2^4 \times 3 \times 5 = (2^2)(2 \times 3)h$$

$$h = 10$$

Height is 20 cm

Answer \_\_\_\_\_ cm [2]

4. Violet intends to arrange  $n$  regular pentagons in a ring. The diagram shows the partially completed ring. Find  $n$ .

$$\begin{aligned} \text{Interior angle of the regular pentagon} &= \frac{180(5-2)}{5} \\ &= 108 \end{aligned}$$

$$\begin{aligned} \text{Interior angle of the regular } n\text{-side polygon form} \\ \text{in the centre of the ring} &= 360 - 2(108) \\ &= 144 \end{aligned}$$

$$144 = \frac{180(n-2)}{n}$$

$$144n = 180n - 360$$

$$36n = 360$$

$$n = 10$$

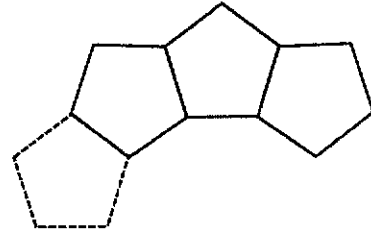

Answer  $n =$  \_\_\_\_\_ [3]

- 5 The bar chart shows the number of traffic accidents resulting in injury from 2014 to 2018. (<https://www.budgetdirect.com.sg/car-insurance/research/road-accident-statistics-in-singapore>)

**Number of Accidents Resulting in Injuries (2014 – 2018)**

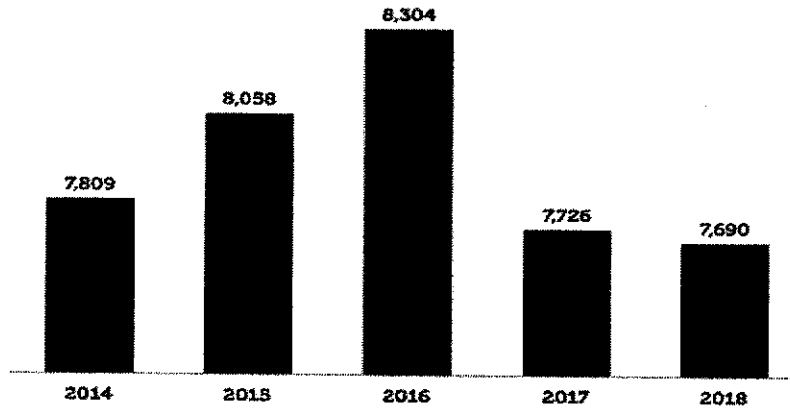

State how this bar chart can be misleading to the reader.

[1]

The bars in the bar chart do not start from zero. The relative heights of the bars can mislead the reader into thinking the differences are larger than what is actually given. For example, The frequency for 2016 is 8304 and the frequency for 2017 is 7726, so the difference is 578, but the height of the 2016 bar is twice that for the 2017 bar.

6 (a) Given that

$$\zeta = \{\text{all triangles}\}$$

$$R = \{\text{right-angled triangles}\}$$

$$S = \{\text{triangles with three unequal sides}\}$$

$A$  is a triangle with  $45^\circ$ ,  $45^\circ$  and  $90^\circ$ .

$B$  is a triangle with 7 cm, 7 cm and 3 cm.

$C$  is a triangle with sides 9 cm, 12 cm and 15 cm.

Represent the above information on a Venn Diagram in the space below.

[2]

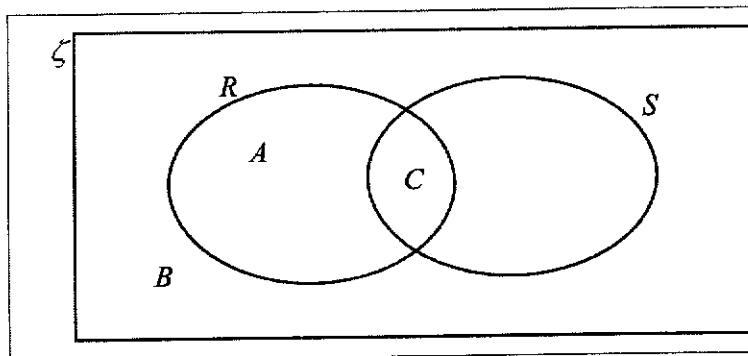

(b) Write down the sets represented by the following shaded region

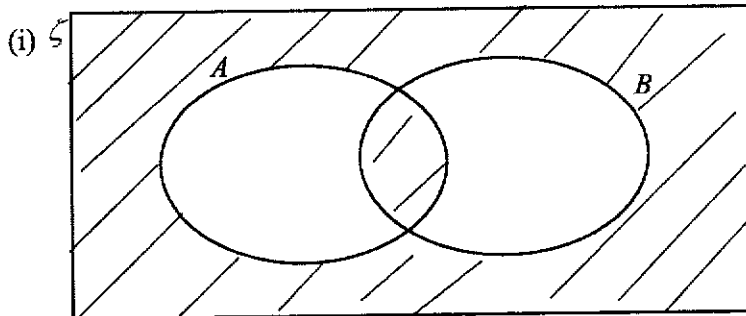

Answer \_\_\_\_\_ [1]

$$(A \cup B)' \cup (A \cap B)$$

7 The speed of light is  $3 \times 10^8$  m/s. Earth is 150 million km from the sun. How long does light take to travel from the sun to the earth. Round your answer to the nearest minute.

$$\begin{aligned} \frac{150000000}{3 \times 10^5} &= 500 \text{ s} \\ &= 8.33 \text{ minutes} \\ &= 8 \text{ minutes (nearest minute)} \end{aligned}$$

Answer \_\_\_\_\_ minutes [2]

- 8 A maximum quadratic curve with the equation  $y = -x^2 + bx + c$  has a turning point at  $(3, 7)$ , find the value of  $b$  and of  $c$ .

$$y = -(x-3)^2 + 7$$

$$y = -(x^2 - 6x + 9) + 7$$

$$y = -x^2 + 6x - 9 + 7$$

$$y = -x^2 + 6x - 2$$

Therefore,  $b = 6$  and  $c = -2$ .

- 9 Solve the equation  $\frac{1}{x+1} - \frac{6x^2 - 10}{1 - x^2} = 4$ .

$$\frac{1}{x+1} - \frac{6x^2 - 10}{1 - x^2} = 4$$

$$\frac{1}{x+1} - \frac{6x^2 - 10}{(1-x)(x+1)} = 4$$

$$\frac{1-x}{(1-x)(x+1)} - \frac{6x^2 - 10}{(1-x)(x+1)} = 4$$

$$\frac{1-x-6x^2+10}{(1-x)(x+1)} = 4$$

$$\frac{-6x^2 - x + 11}{(1-x)(x+1)} = 4$$

$$-6x^2 - x + 11 = 4 - 4x^2$$

$$-6x^2 - x + 11 + 4x^2 - 4 = 0$$

$$-2x^2 - x + 7 = 0$$

$$x = \frac{1 \pm \sqrt{(-1)^2 - 4(-2)(7)}}{2(-2)}$$

$$x \approx 1.6375 \text{ or } x \approx -2.1375$$

$$x \approx 1.64 \text{ or } x \approx -2.14$$

Answer  $x =$  \_\_\_\_\_ or  $x =$  \_\_\_\_\_ [4]

10 Simplify  $\frac{27 - 12x^2}{-3 - 2x^2 + 5x} \times \frac{1 - x}{-2x - 3}$ .

$$\begin{aligned} & \frac{27 - 12x^2}{-3 - 2x^2 + 5x} \times \frac{1 - x}{-2x - 3} \\ &= \frac{3(9 - 4x^2)}{(-2x + 3)(x - 1)} \times \frac{1 - x}{-2x - 3} \\ &= \frac{3(3 - 2x)(3 + 2x)}{(-2x + 3)(x - 1)} \times \frac{-(x - 1)}{-(2x + 3)} \\ &= 3 \end{aligned}$$

Answer \_\_\_\_\_ [3]

- 11 In the diagram below,  $XZ$  is the chord of a circle.  $XY$  is the diameter of the circle, centre  $O$ .  
Given that  $XZ = 9$  cm and  $YZ = 63$  cm, calculate

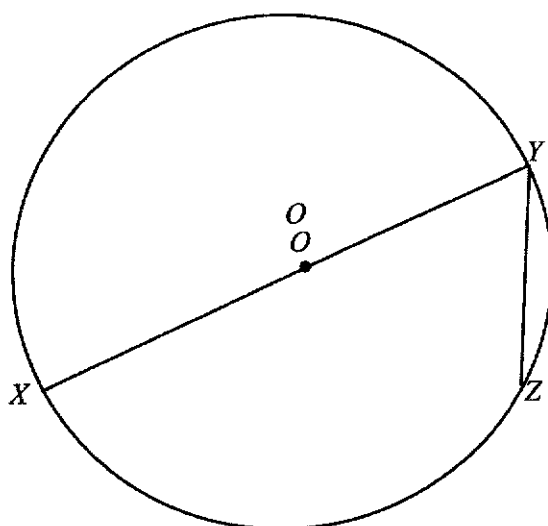

- (a) the length of  $XY$ ,

(a) By using Pythagoras Theorem,

$$\begin{aligned} XY &= \sqrt{9^2 + (63)^2} \\ &= \sqrt{44} \\ &= 12 \end{aligned}$$

Answer  $XY =$  \_\_\_\_\_ [1]

- (b)  $\angle YXZ$ ,

$$\begin{aligned} \text{(b) } \angle YXZ &= \tan^{-1} \left( \frac{63}{9} \right) \\ &= 41.4^\circ \text{ (1d.p)} \end{aligned}$$

Answer  $\angle YXZ =$  \_\_\_\_\_  $^\circ$  [1]



(c)  $\angle YOZ$  in radian,

$\triangle OXZ$  is an isosceles triangle.

$$(c) \angle YOZ = 2 \times \angle YXZ$$

(1 ext angle = sum of int. opp. angle)

$$= 82.8192^\circ$$

$$= 1.45 \text{ rad (3sf)}$$

OR

$\triangle OXZ$  is an isosceles triangle.

$$\angle XOZ = 180^\circ - (2 \times 41.4096^\circ)$$

$$= 97.1807^\circ (\angle \text{ on a str. line})$$

$$\angle YOZ = \pi - \left( \frac{97.1807}{180} \right) \pi$$

$$= 1.45 \text{ rad (3s.f)}$$

Answer  $\angle YOZ =$  \_\_\_\_\_ rad [2]

(d) the area of the major segment  $YZ$ .

(d) Area of the major segment  $YZ$

= area of major sector  $YOZ$  + area of triangle  $YOZ$

$$= \frac{1}{2} (6)^2 (2\pi - 1.445469) + \frac{1}{2} (6)^2 \sin(1.445469)$$

$$= 105 \text{ cm}^2 \text{ (3s.f)}$$

OR

$$\text{Area of major sector } YOZ = \frac{360 - 82.8192}{360} \times \pi (6)^2$$

$$= 87.0789 \text{ cm}^2$$

$$\text{Area of triangle } YOZ = \frac{1}{2} \times (6)^2 \times \sin(82.8192)$$

$$= 17.8168 \text{ cm}^2$$

$$\text{Area of major segment } YZ = 105 \text{ cm}^2 \text{ (3s.f)}$$

Answer = \_\_\_\_\_  $\text{cm}^2$  [3]

12

$y = x^3 - 4$	$y = -3(4)^x$	$y = 4 - x^2$	$y = 4x^{-2}$
$y = -2x^{-4}$	$y = 4 - x^3$	$y = -3(-4)^x$	$y = x^2 + 4$

Write down a possible equation for each of the sketch graphs below.  
In each case select one of the equations from the box above.

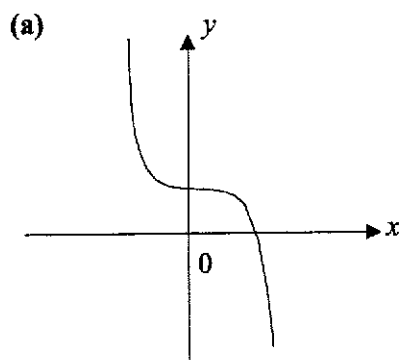

(a)  $y = 4 - x^3$

(b)

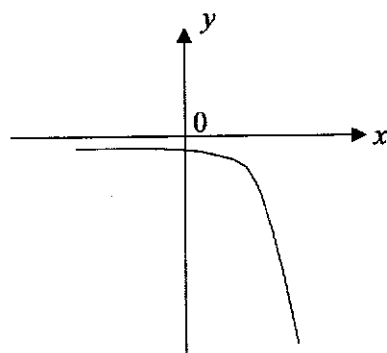

(b)  $y = -3(4)^x$

- 13 Make  $x$  the subject in the equation  $y = \sqrt{x^2 - 8x + 16} - y^2$ .

$$\begin{aligned}
 y &= \sqrt{x^2 - 8x + 16} - y^2 \\
 y^2 &= x^2 - 8x + 16 - y^2 \\
 2y^2 &= x^2 - 8x + 16 \\
 2y^2 &= (x - 4)^2 \\
 x - 4 &= \pm \sqrt{2}y \\
 x &= 4 \pm 2y
 \end{aligned}$$

Answer \_\_\_\_\_ [3]

- 14 In the diagram shown below, it is given that  $AP = 5$  cm,  $BP = 2$  cm and  $AR = 3$  cm.  $ARC$ ,  $ABP$  and  $RQP$  are straight lines. Show, with clear reasons, that triangle  $ABC$  is congruent to triangle  $ARP$ .

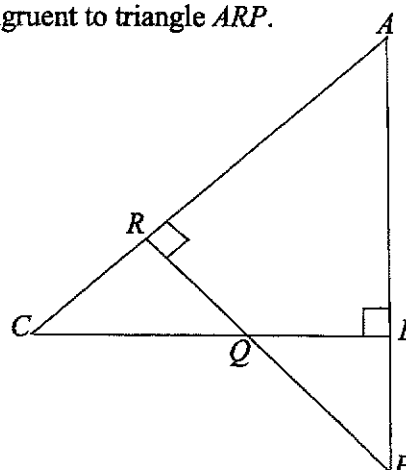

[2]

In triangle  $ABC$  and triangle  $ARP$ ,

Angle  $A$  is common.  
 Angle  $ABC = \text{Angle } ARP = 90^\circ$  (given)  
 $AB = 5 - 2 = 3$  cm =  $AR$   
 Therefore triangle  $ABC \cong$  triangle  $ARP$  (AAS)

- 15 A lake has an actual area of  $2.5 \text{ km}^2$ . The area of the lake on the map is  $40 \text{ cm}^2$ . The distance between two towns on the map is  $45$  cm. Find the actual distance, in kilometres, between the two towns.

$$\begin{aligned}
 \text{Area Scale} &= 40 \text{ cm}^2 : 2.5 \text{ km}^2 \\
 &= 40 \text{ cm}^2 : 2.5 \times 100000 \times 100000 \text{ cm}^2 \\
 &= 1 : 625000000 \\
 \text{Linear Scale} &= 1 : 25000 \\
 &= 1 \text{ cm} : 0.25 \text{ km} \\
 &= 45 \text{ cm} : 11.25 \text{ km}
 \end{aligned}$$

OR

40 cm<sup>2</sup> on the map = 2.5 km<sup>2</sup> on the ground

$\sqrt{40}$  cm on the map =  $\sqrt{2.5}$  km on the ground

$$1 \text{ cm} = \frac{\sqrt{2.5}}{\sqrt{40}} \text{ km}$$

$$45 \text{ cm} = 45 \times \frac{\sqrt{2.5}}{\sqrt{40}} = 11.25 \text{ km}$$

OR

Let the distance between the two towns be  $d$  km.

$$\left(\frac{45}{d}\right)^2 = \frac{40}{2.5}$$

$$\frac{2025}{d^2} = 16$$

$$d^2 = \frac{2025}{16}$$

$$d = \frac{45}{4} \quad (d > 0)$$

Answer \_\_\_\_\_ km [3]

- 16 (a) Solve the inequalities  $\frac{8x-12}{2} \leq 3x+1 < \frac{17x}{3}$ .

$$\frac{8x-12}{2} \leq 3x+1 < \frac{17x}{3}$$

$$\frac{8x-12}{2} \leq 3x+1 \quad \text{and} \quad 3x+1 < \frac{17x}{3}$$

$$8x-12 \leq 6x+2 \quad 3x+1 < \frac{17x}{3}$$

$$8x-6x \leq 2+12 \quad 9x+3 < 17x$$

$$2x \leq 14 \quad \text{and} \quad 9x-17x < -3$$

$$x \leq 7 \quad -8x < -3$$

$$x > \frac{3}{8}$$

Therefore,  $\frac{3}{8} < x \leq 7$

Answer \_\_\_\_\_ [3]

- (b) Hence, write down all the prime numbers that satisfy  $\frac{8x-12}{2} \leq 3x+1 < \frac{17x}{3}$ .

The prime numbers are 2, 3, 5 and 7

Answer \_\_\_\_\_ [1]

17 Factorise completely  $4x^2 - 12xy + 9y^2 - 1$ .

$$4x^2 - 12xy + 9y^2 - 1 = (2x - 3y)^2 - 1^2$$

$$= (2x - 3y - 1)(2x - 3y + 1)$$

Answer \_\_\_\_\_ [2]

18 The Venn diagram shows the elements of  $\xi$  and three sets  $A, B$  and  $C$ .  
 $\xi = \{x: x \text{ is a positive integer such that } 0 < x < 14\}$

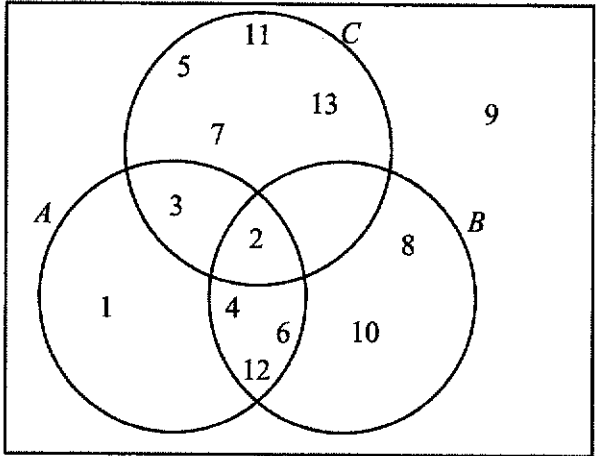

(a) Describe in words the elements in set  $C$ .

(a) The elements in set  $C$  are the prime numbers between 0 and 14.  
 OR The set  $C$  is the set of prime numbers.

(b) Use one of the symbols below to complete each statement.

$\emptyset \subset \not\subset \notin \in \xi$

(i)  $A' \cap (B \cap C) = \dots\dots\dots$

(ii)  $3 \dots\dots\dots A$

(b) (i)  $\emptyset$   
 (ii)  $\in$

- 19 The time taken to assemble a car is inversely proportional to the number of workers involved. 4 workers can complete the assembly in  $x$  days. If 6 more workers are involved, the assembly can be completed 3 days in advance.

(a) Find the value of  $x$ .

$$\begin{aligned} \text{Let } W &= \text{number of works, } D = \text{number of days required} \\ x &= \frac{k}{4} \\ k &= 4x \\ x-3 &= \frac{k}{10} \\ k &= 10x-30 \\ 10x-30 &= 4x \\ x &= 5 \end{aligned}$$

Answer  $x =$  \_\_\_\_\_ [2]

(b) Find the number of workers required if the assembly is to be completed in 2 days.

$$\begin{aligned} \text{(b) When } x &= 5, \\ 5 &= \frac{k}{4} \\ k &= 20 \\ D &= \frac{20}{W} \\ \text{When } D &= 2 \text{ days, } W = 10 \text{ workers.} \end{aligned}$$

Answer \_\_\_\_\_ [2]

- 20 In the figure,  $ABCD$  is a quadrilateral. The point  $X$  is such that  $XB$  and  $XD$  are the angle bisectors of angle  $ABC$  and angle  $ADC$  respectively.

Reflex angle  $BCD = 200^\circ$  and reflex angle  $BXD = 225^\circ$ .

Calculate angle  $BAD$ .

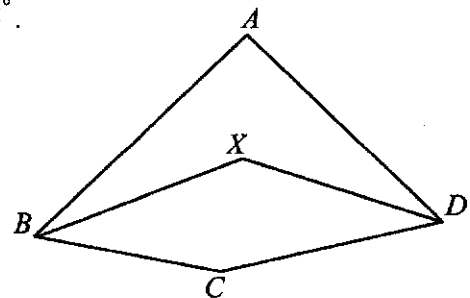

$$\begin{aligned} \text{Obtuse angle } BCD &= 360^\circ - 200^\circ = 160^\circ \text{ (Angles at a point)} \\ \text{Obtuse angle } BXD &= 360^\circ - 225^\circ = 135^\circ \text{ (Angles at a point)} \\ \text{Angle } CBX + \text{angle } CDX &= 360^\circ - 160^\circ - 135^\circ = 65^\circ \text{ (angle sum of quadrilateral } BCDX) \\ \text{Since } XB \text{ and } XD &\text{ bisect angle } ABC \text{ and angle } ADC \text{ respectively.} \\ \text{Angle } ABC + \text{angle } ADC &= (\angle CBX + \angle CDX) \times 2 \\ &= 65^\circ \times 2 = 130^\circ \\ \text{Angle } BAD &= 360^\circ - 130^\circ - 160^\circ = 70^\circ \text{ (angle sum of quadrilateral } ABCD) \end{aligned}$$

Answer \_\_\_\_\_ [4]

- 21 (a) An open container in a shape of an inverted cone has radius of 10 cm and height of 30 cm. Water is poured into the container at a constant rate of  $5\pi \text{ cm}^3/\text{s}$  until it is completely filled to the brim.  
Find the time taken for the container to be completely filled.

<p>(a) Volume of conical container <math>= \frac{1}{3} \pi (10)^2 (30)</math>  <math>= 1000 \pi \text{ cm}^3</math></p> <p>Time taken <math>= \frac{1000\pi}{5\pi}</math>  <math>= 200 \text{ s}</math></p>	
---	--

Answer \_\_\_\_\_ s [1]

- (b) Sketch the graph of the water-level against time below.

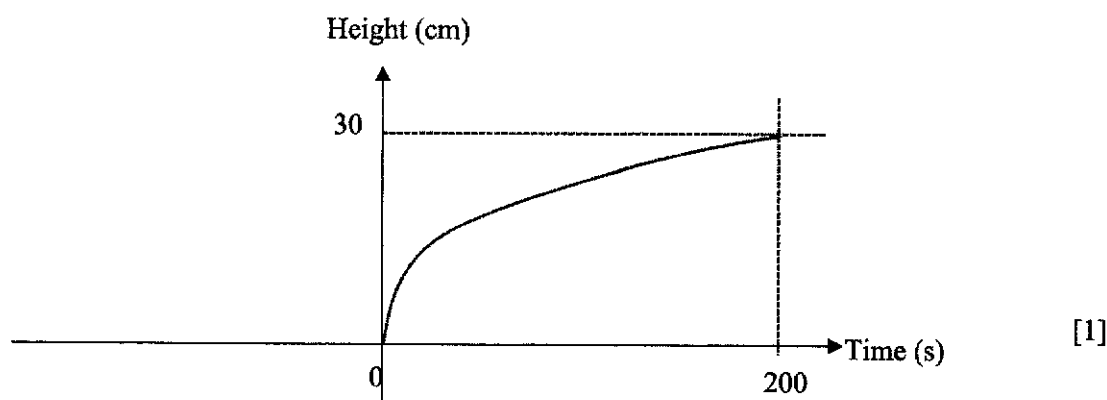

- 22 A popular drink is produced in two similar bottle sizes. The height of the large bottle  $A$  is 18 cm while the height of the smaller bottle  $B$  is 12 cm.

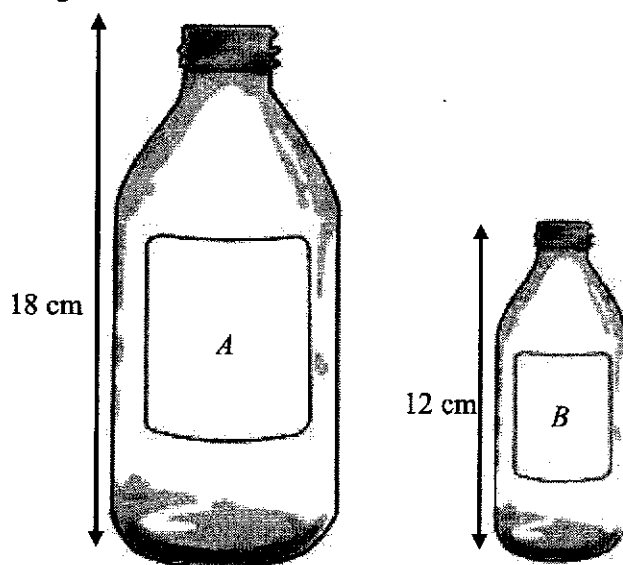

If the selling prices of bottles  $A$  and  $B$  are \$24.90 and \$6.90 respectively, which bottle provides better value for money? Justify your answer clearly. [3]

$$\frac{\text{Volume of A}}{\text{Volume of B}} = \left(\frac{18}{12}\right)^3 = \frac{5832}{1728} = \frac{27}{8}$$

$$\text{Cost of 1 unit}^3 \text{ of volume for A} = \frac{\$24.90}{27} \\ \approx \$0.9222$$

$$\text{Cost of 1 unit}^3 \text{ of volume for B} = \frac{\$6.90}{8} \\ \approx \$0.8625$$

Since 1 unit<sup>3</sup> of liquid in bottle B cost lesser than 1 unit<sup>3</sup> of liquid in bottle A, bottle B is more value for money.

Note: Only award first method mark if student use 1cm<sup>3</sup> instead of 1unit<sup>3</sup>

- 23 The cumulative frequency diagram shows the times taken by 200 girls from school A running 2.4 km test. The box-and-whisker pot shows the times for another group of girls from school B.

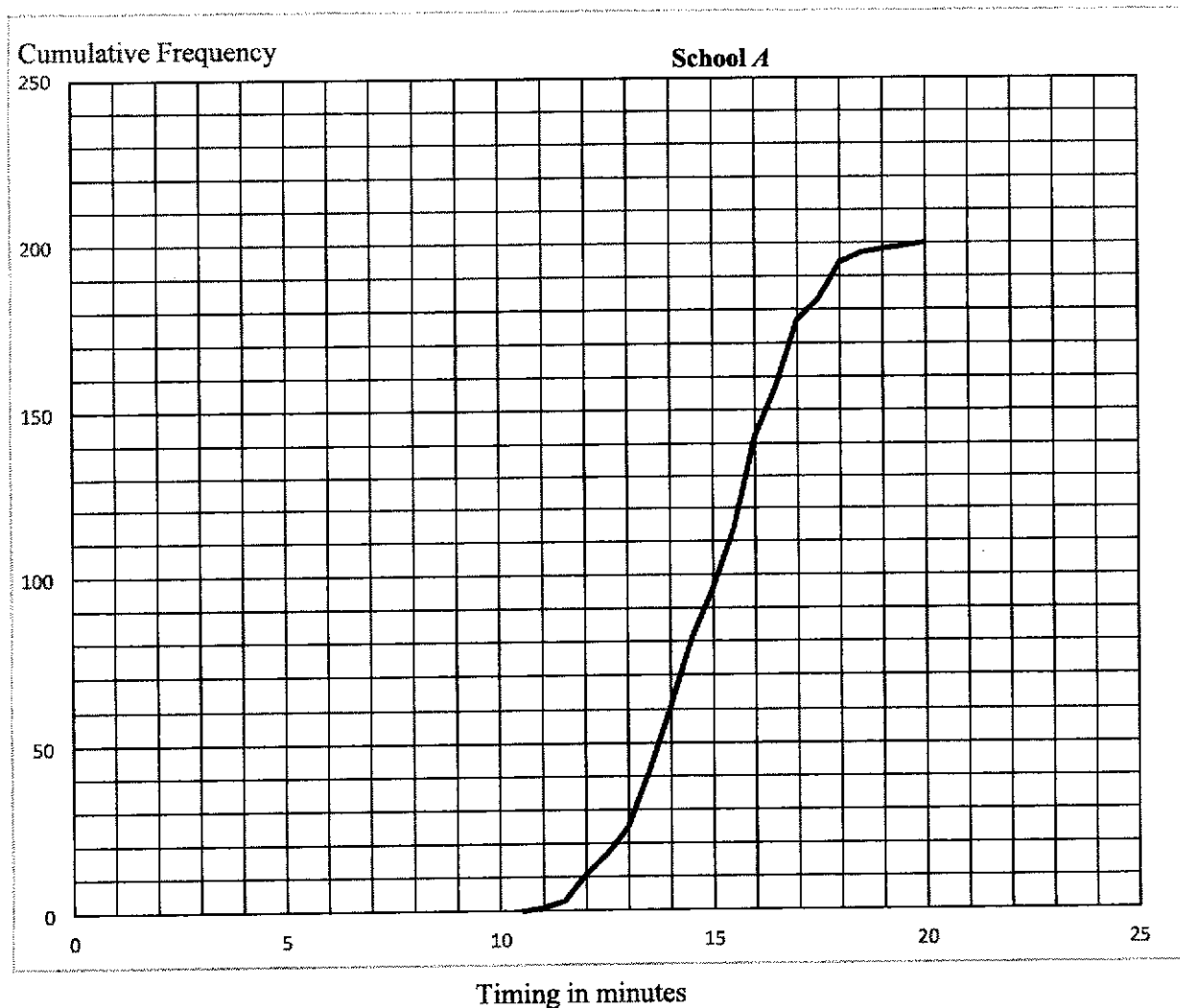



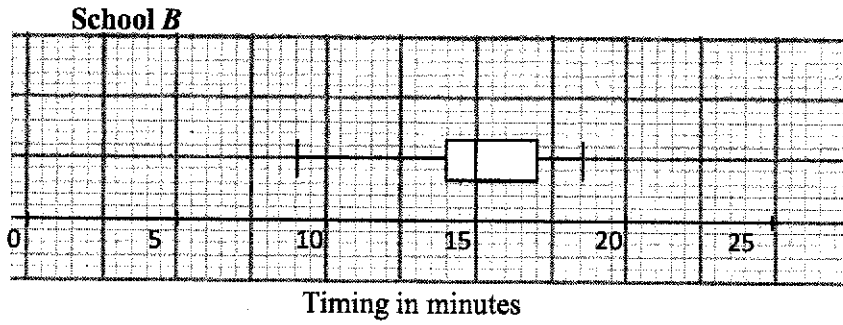

- (a) 75% of the girls in school B failed the test. Find the number of girls who passed in school A.

(a) From school B,  $Q_1 = 14$  mins, which is the passing time.  
Hence, number of girls in school A who passed the test  
= 60 (from curve)

Answer..... [1]

- (b) 30% of the girls in school A took longer than  $t$  minutes. Find  $t$ . [2]

30% of the girls =  $\frac{30}{100} \times 200 = 60$   
From the curve, 140 girls took 16 minutes or less. So  $t = 16$

Answer..... [2]

- (c) Find the proportion of girls in school A who took between 14.5 minutes and 17 minutes to complete the run.

$t = 14.5$  Cumulative Frequency = 80  
 $t = 17$  Cumulative Frequency = 177  
Proportion of girls =  $\frac{177 - 80}{200} \times 100 = 48.5\%$

Answer..... [2]

- 24 (a) Construct kite  $ABCD$ .  $AD = CD = 9$  cm.  $AB$  and  $BC$  have already been drawn. Measure and state the length of the longest diagonal.

Answer

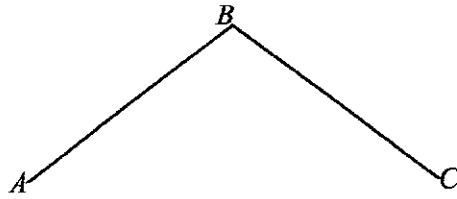

(a) Construct

Length of longest diagonal = 6.9cm – 7.1cm

- (b) Construct the perpendicular bisector  $BC$ . [1]
- (c) Construct the bisector of the angle  $ABC$ . [1]
- (b) / (c) See diagram
- (d)  $ABCD$  represents a plot of land which is to be used for a park. A café is to be built in park, nearer to  $A$  than to  $D$  and nearer to  $AD$  than  $AB$ . Shade the region where the café is to be built.
- (d) See diagram

- 25 Ahmad and Beng Hai want to rent lockers in school. The lockers are in two levels. Lockers 1A to 1C are on the lower level and Lockers 2A to 2C are on the next level. Lockers are assigned to each student randomly.

- (e) Using a possibility diagram, represent the two lockers that the two boys can be allocated such that they are next to each other on the same level.

Answer

		Ahmad					
Beng Hai		1A	1B	1C	2A	2B	2C
	1A		1	1	1	1	1
	1B	1		1	1	1	1
	1C	1	1		1	1	1
	2A	1	1	1		1	1
	2B	1	1	1	1		1
	2C	1	1	1	1	1	

[2]

- (b) Find the probability that Ahmad and Beng Hai are randomly allocated lockers next to each other on Level 2.

Total number of possible outcomes = 30 $P(\text{Ahmad and Beng Hai have lockers on Level 2})$ $= \frac{4}{30} = \frac{2}{15}$	
---	--

Answer \_\_\_\_\_ [1]

- (c) Find the probability that Ahmad and Beng Hai are randomly allocated lockers on different levels.

Total number of possible outcomes = 30 $P(\text{Ahmad and Beng Hai have lockers on different levels})$ $= \frac{18}{30} = \frac{3}{5}$	
--	--

Answer \_\_\_\_\_ [1]

- (d) If the lockers 2C was not available. Find the probability that the friends will be allocated lockers next to each other at any level.

Total number of possible outcomes = 20 $P(\text{Ahmad and Beng Hai have lockers next to each other})$ $= \frac{6}{20} = \frac{3}{10}$
---

Answer \_\_\_\_\_ [2]

**End of paper**

Qn	Solutions	
<b>1</b>	A sequence is given by the formula $P_{n+1} = (P_n)^2 + mP_n$ , where $m$ is a constant.	
<b>1a</b>	Given that $P_1 = 3$ , show that $P_2 = 3m + 9$ .	
	$P_2 = (P_1)^2 + m(P_1)$ $= 3^2 + m(3)$ $= 3m + 9 \text{ (shown)}$	
<b>1b</b>	Given that $P_2 = -\frac{3}{4}$ , find the value of $m$ ,	
	$P_2 = -\frac{3}{4}$ $3m + 9 = -\frac{3}{4}$ $m = \left( -\frac{3}{4} - 9 \right) \div 3 = -3\frac{1}{4}$ <p>(accept <math>-3.25, -\frac{13}{4}</math>)</p>	
<b>1ci</b>	By using the answer in (b), find $P_3, P_4$ and $P_5$ .	
	$P_3 = \left( -\frac{3}{4} \right)^2 + \left( -\frac{13}{4} \right) \left( -\frac{3}{4} \right) = 3$ $P_4 = (3)^2 + \left( -\frac{13}{4} \right) (3) = -\frac{3}{4}$ $P_5 = \left( -\frac{3}{4} \right)^2 + \left( -\frac{13}{4} \right) \left( -\frac{3}{4} \right) = 3$	
<b>1cii</b>	By considering the terms of $P_1, P_2, P_3, P_4$ and $P_5$ or otherwise, find the value of $P_{2016}$ .	
	$P_1 = 3$ $P_2 = -\frac{3}{4}$ $P_3 = 3$ $P_4 = -\frac{3}{4}$ $P_5 = 3$ $P_{2016} = 3 \left( -\frac{13}{4} \right) + 9 = -\frac{3}{4}$	

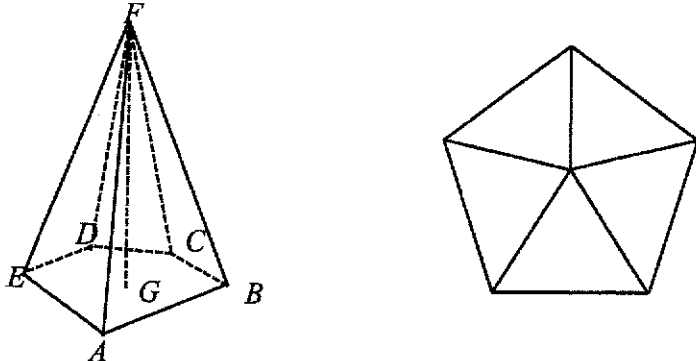
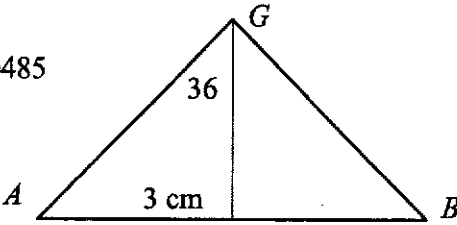
2a	<p>The diagram shows a pyramid <math>ABCDEF</math>. The base of the pyramid is a regular pentagon of side 6 cm. The tip <math>F</math> is vertically above the centre of the pentagon, <math>G</math>, and <math>AF = 14</math> cm. Calculate the angle <math>AGB</math>.</p> 	
	$\text{angle } AGB = \frac{360}{5} = 72^\circ$	
2b	<p>Show that <math>AG = 5.1039</math> cm, correct to five significant figures.</p>	[2]
	$\frac{3}{AG} = \sin 36^\circ$ $AG = \frac{3}{\sin 36^\circ} = 5.10390485$ $= 5.1039 \text{ cm}$ 	
2c	<p>Calculate the height of the pyramid, <math>FG</math>.</p>	[2]
	$FG^2 = AF^2 - AG^2$ $FG^2 = 14^2 - 5.10390485^2 = 169.9501553$ $FG = 13.03649321 = 13.0 \text{ cm}$	
2d	<p>The pyramid is the model for a paper weight that is to be gold plated. To reduce costs the pyramid is made smaller such that the smaller pyramid remains geometrically similar to the original pyramid but its height is reduced by 35%.</p> <p>The surface area of the large pyramid is <math>S \text{ cm}^3</math>. Express the surface area of the new pyramid as a percentage of <math>S</math>.</p>	[3]
	$FG = 13.03649321 \text{ cm}$ $\text{New height} = 0.65 \times 13.03649321$ $= 8.473720587 \text{ cm}$	

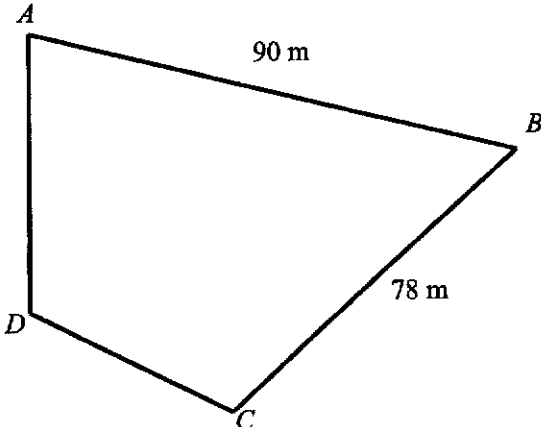
	$\frac{\text{Surface of small pyramid}}{S} = \frac{8.473720587^2}{13.03649321^2} = 0.4225$ <p>Surface of small pyramid = 0.4225S</p> $\text{The percentage} = \frac{S - 0.4225S}{S} \times 100$ $= 57.75\%$	
<b>3i</b>	<p>Given that the points <math>P(3, k)</math>, <math>Q(1, -2)</math> and <math>R(-4, -6k)</math> lie on a straight line, find the value of <math>k</math>.</p> <p>Gradient of <math>AB =</math> Gradient of <math>AC</math></p> $\frac{-2 - k}{1 - 3} = \frac{-6k - k}{-4 - 3}$ $-7(-2 - k) = -2(-7k)$ $14 + 7k = 14k$ $k = 2$	
<b>3ii</b>	<p>Find the length of the line segment <math>PQ</math>.</p> $\text{Length of line segment } PQ = \sqrt{(3-1)^2 + (2-(-2))^2}$ $= \sqrt{4+16}$ $= 20$ $= 4.47 \text{ unit (3s.f)}$	
<b>4</b>	<p>Quadrilateral <math>ABCD</math> is a field with <math>AB = 90</math> m and <math>BC = 78</math> m and <math>A</math> is due north of <math>D</math>. The bearing of <math>B</math> from <math>A</math> is <math>100^\circ</math>, the bearing of <math>B</math> from <math>C</math> is <math>025^\circ</math> and the bearing of <math>D</math> from <math>C</math> is <math>278^\circ</math>.</p> 	

<b>4ai</b>	Show that angle $ABC = 75^\circ$ .	
	Draw a north line on point $B$ . Label due south point as $E$ . $\angle EBA = 100^\circ$ (alt. $\angle$ , $BE \parallel DA$ ) $\angle EBC = 25^\circ$ ( alt. $\angle$ to bearing of $B$ from $C$ ) $\angle ABC = 75^\circ$	
<b>4aii</b>	Calculate the bearing of $C$ from $D$ ,	
	Draw a north line on point $C$ . Label due south point as $F$ . $\angle FCD = 278^\circ - 180^\circ$ $= 98^\circ$ The bearing of $C$ from $D = 098^\circ$	
<b>4aii</b>	Calculate the length of $AC$ .	
	Using cosine rule, $AC^2 = 90^2 + 78^2 - 2(90)(78)\cos 75^\circ$ $AC = \sqrt{05550.18061}$ $AC = 102.714\text{m}$ $AC = 103\text{m}$ (3s.f)	
<b>4bi</b>	A drone hovers at a height of 70 m above $D$ . A man of height 1.75m walks along path $AC$ . He stopped at $E$ to take a picture of the drone when the maximum angle of depression from the drone to the top of the man's head was $58^\circ$ . Calculate the length of $DE$ .	
	Vertical height of the drone from man $= (70 - 1.75)\text{m}$ $= 68.25\text{m}$ $\tan 58^\circ = \frac{68.25}{DE}$ $DE = 42.647\text{ m}$ $DE = 42.6\text{ m}$ (3s.f) Note: If student didnt consider the height of the man in the calculation, zero mark.	
<b>4bii</b>	Calculate the area of the field $ABCD$ .	
	Area of $ABCD = \frac{1}{2}(102.714)(42.647) + \frac{1}{2}(90)(78)\sin 75^\circ$ $= 5580.621\text{m}^2$ $= 5580\text{ m}^2$ (3s.f)	
<b>5</b>	Adam runs a drink stall franchise in 4 locations. The number of cups for each type of drink sold a day is shown in the table below.	

	Location	Types of Drink											
		Coffee	Tea	Fruit Juice									
	Branch A	60	42	5									
	Branch B	24	30	0									
	Branch C	30	35	14									
	Branch D	30	40	20									
<b>5a</b>	Represent the above information as a $4 \times 3$ matrix <b>P</b> .				[1]								
	$\mathbf{P} = \begin{pmatrix} 60 & 42 & 5 \\ 24 & 30 & 0 \\ 30 & 35 & 14 \\ 30 & 40 & 20 \end{pmatrix}$												
<b>5b</b>	The price of drinks are shown in the table below.												
	<table border="1"> <thead> <tr> <th>Drink</th> <th>Price (SGD\$)</th> </tr> </thead> <tbody> <tr> <td>Coffee</td> <td>1.50</td> </tr> <tr> <td>Tea</td> <td>1</td> </tr> <tr> <td>Fruit Juice</td> <td>2</td> </tr> </tbody> </table>				Drink	Price (SGD\$)	Coffee	1.50	Tea	1	Fruit Juice	2	
Drink	Price (SGD\$)												
Coffee	1.50												
Tea	1												
Fruit Juice	2												
	Represent the above information as a $3 \times 1$ matrix <b>N</b> .												
	$\mathbf{N} = \begin{pmatrix} 1.5 \\ 1 \\ 2 \end{pmatrix}$												
<b>5c</b>	Evaluate the matrix $\mathbf{T} = \mathbf{PN}$ .				[1]								
	$\mathbf{T} = \begin{pmatrix} 60 & 42 & 5 \\ 24 & 30 & 0 \\ 30 & 35 & 14 \\ 30 & 40 & 20 \end{pmatrix} \begin{pmatrix} 1.5 \\ 1 \\ 2 \end{pmatrix}$ $= \begin{pmatrix} 142 \\ 66 \\ 108 \\ 125 \end{pmatrix}$												
<b>5d</b>	State what each of the elements of matrix <b>T</b> represents.												
	<p>The elements of matrix <b>T</b> represent the total amount of money collected from all the drinks from branch A, B, C and D respectively.</p> <p>Or</p> <p>The elements of matrix <b>T</b> represent the total amount of money collected from all the drinks from each branch respectively.</p>												



	<p>Or</p> <p>The elements of matrix T represent the amount of money collected from all the drinks from branch A, B, C and D respectively.</p> <p>Or</p> <p>The elements of matrix T represent the amount of money collected from all the drinks from each branch respectively.</p>																		
<b>5ei</b>	<p>The cost of all the ingredients per day for Branch A, B, C and D is shown in the table below.</p> <table border="1" style="margin-left: auto; margin-right: auto;"> <thead> <tr> <th rowspan="2">Branch</th> <th colspan="2">All ingredients for drinks</th> </tr> <tr> <th>In USD</th> <th>In SGD</th> </tr> </thead> <tbody> <tr> <td>A</td> <td><math>p</math></td> <td>27</td> </tr> <tr> <td>B</td> <td>12</td> <td>16.20</td> </tr> <tr> <td>C</td> <td>16</td> <td>21.60</td> </tr> <tr> <td>D</td> <td>23</td> <td><math>q</math></td> </tr> </tbody> </table> <p>Find the value of <math>p</math> and <math>q</math>.</p>	Branch	All ingredients for drinks		In USD	In SGD	A	$p$	27	B	12	16.20	C	16	21.60	D	23	$q$	[2]
Branch	All ingredients for drinks																		
	In USD	In SGD																	
A	$p$	27																	
B	12	16.20																	
C	16	21.60																	
D	23	$q$																	
	<p><math>p = 20</math> <math>q = 31.05</math></p>																		
<b>5eii</b>	<p>The rental and operating cost per day for Branch A, B, C and D is shown in the table below.</p> <table border="1" style="margin-left: auto; margin-right: auto;"> <thead> <tr> <th>Branch</th> <th>Rental &amp; Operating Cost (SGD)</th> </tr> </thead> <tbody> <tr> <td>A</td> <td>40</td> </tr> <tr> <td>B</td> <td>45</td> </tr> <tr> <td>C</td> <td>50</td> </tr> <tr> <td>D</td> <td>60</td> </tr> </tbody> </table> <p>Using matrix operations, calculate the total amount of profit in SGD Adam made that day.</p>	Branch	Rental & Operating Cost (SGD)	A	40	B	45	C	50	D	60	[2]							
Branch	Rental & Operating Cost (SGD)																		
A	40																		
B	45																		
C	50																		
D	60																		
	$\begin{pmatrix} 142 \\ 66 \\ 108 \\ 125 \end{pmatrix} - \begin{pmatrix} 40 \\ 45 \\ 50 \\ 60 \end{pmatrix} - \begin{pmatrix} 27 \\ 16.20 \\ 21.60 \\ 31.05 \end{pmatrix} = \begin{pmatrix} 75 \\ 4.8 \\ 36.4 \\ 33.95 \end{pmatrix}$ $(1111) \begin{pmatrix} 75 \\ 4.8 \\ 36.4 \\ 33.95 \end{pmatrix} = (150.15)$ <p>The total amount of profit Adam made is \$150.15.</p>																		

<b>6</b>	44 boys ran the 2.4 km and their timings are shown in the table.						
	$t$ (minutes)	$8 \leq t < 9$	$9 \leq t < 10$	$10 \leq t < 11$	$11 \leq t < 12$	$12 \leq t < 13$	$13 \leq t < 14$
	Frequenc $y$	1	$h$	12	11	$k$	6
<b>6a</b>	The estimated mean timing is 11.477 minutes. Estimate to the nearest integer the value of $h$ and the value of $k$ .						[4]
	$1 + h + 12 + 11 + k + 6 = 44$ $h + k = 14$ $\frac{1(8.5) + h(9.5) + 12(10.5) + 11(11.5) + k(12.5) + 6(13.5)}{44} = 11.477$ $9.5h + 12.5k = 162.988$ $9.5(14 - k) + 12.5k = 162.988$ $3k = 29.988$ $k = 9.996$ $= 10$ <p>So <math>h = 4</math></p>						
<b>6b</b>	Estimate the standard deviation.						[1]
	Standard Deviation = $\sqrt{\frac{5867}{44} - (11.477)^2} = 1.2701$ minutes						
<b>6c</b>	Explain why in this case, the mean is better than the median as a measure of central tendency.						[1]
	There are no outliers.						
<b>6d</b>	Another group of 35 boys ran the 2.4 km and their mean and standard deviation were 11.7 minutes and 2.10 minutes respectively. Comment on the timings of these two groups of boys.						[2]
	The first group of boys is faster as their mean of 11.477 minutes is less than the mean of the second group with mean 11.7 minutes.						
	The timings for the first group is more consistent as their standard deviation of 1.27 minutes is less than that for the second group at 2.10 minutes.						
<b>7</b>	It is given that point $A$ lies on the $y$ -axis while point $B$ lies on the $x$ -axis such that $OB = 2OA$ , where $O$ is the origin. given that the line $AB$ passes through the point						[3]

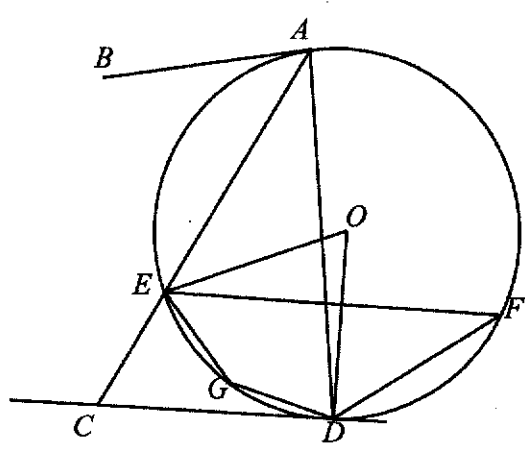
	$\left(4, \frac{5}{2}\right)$ , find the equation of the line $AB$ .	
	<p>Gradient of line <math>AB = -\frac{1}{2}</math></p> <p>Equation of line <math>AB</math> is in the form <math>y = mx + c</math> and using the given point <math>\left(4, \frac{5}{2}\right)</math>,</p> $\frac{5}{2} = -\frac{1}{2}(4) + c$ $c = \frac{9}{2}$ $\therefore y_{AB} = -\frac{1}{2}x + \frac{9}{2}$	
<b>8</b>	<p>In the diagram, line <math>AB</math> and line <math>CD</math> are tangents to point <math>A</math> and point <math>D</math> respectively on the circumference of the circle with centre <math>O</math>. Angle <math>DAE = 33^\circ</math>, angle <math>ECD = 59^\circ</math> and <math>AEC</math> is a straight line. <math>E, F</math>, and <math>G</math> are points on the circumference of the circle.</p> 	
<b>8a</b>	Find angle $EOD$ .	[1]
	Angle $EOD = 66^\circ$ (angle at centre = 2 angle at circumference)	
<b>8b</b>	Find angle $EFD$	
	Angle $EFD = 33^\circ$ (angle in same segment)	
<b>8c</b>	Find angle $EGD$	
	Angle $EGD = 147^\circ$ (angle in opp segment)	
<b>8d</b>	A circle is drawn with the line $AC$ as its diameter. Explain why point $D$ will not lie on the circumference of the circle.	[2]

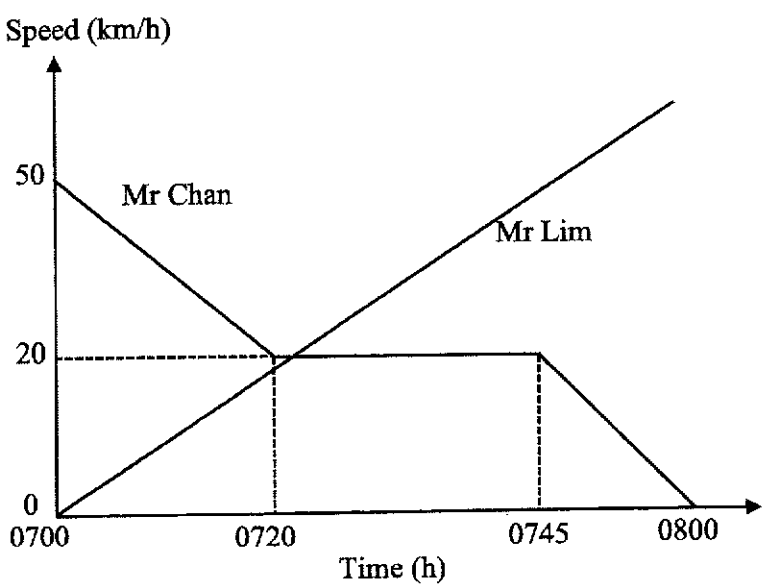
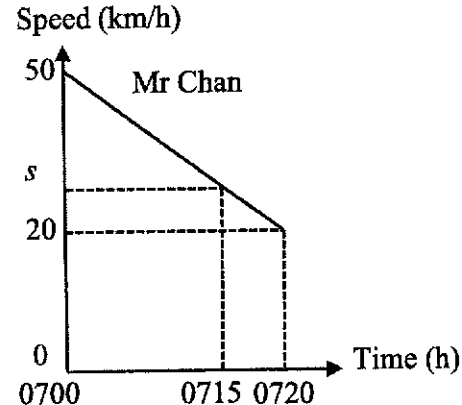
	<p>Angle <math>ADC = 180^\circ - 59^\circ - 33^\circ = 88^\circ</math>, and is <u>not</u> <math>90^\circ</math>, <u>angle in semicircle property does not apply</u> and hence <math>A</math> will not lie on the circumference of the circle.</p>	
8e	<p>Line <math>AB</math> and <math>CD</math> are extended and meet at <math>T</math>. Find the angle <math>ATD</math>.</p> <p>Angle <math>ADC = 180^\circ - 33^\circ - 59^\circ = 88^\circ</math>              Angle <math>ODA = \text{angle } OAD = 90^\circ - 88^\circ = 2^\circ</math>. (tan perpendicular to rad, base of isosceles triangle)              Angle <math>BAD = 90^\circ - 2^\circ = 88^\circ</math> (tan perpendicular to rad)              Angle <math>ATD = 180^\circ - 88^\circ - 88^\circ = 4^\circ</math> (angle sum of triangle)</p>	
9	<p>Mr Chan driving a car at 50 km/h passes a lamppost A and stops at lamppost B, one hour later. When Mr Chan passes the lamppost A, Mr Lim, on a motorcycle, starts from A and overtakes Mr Chan. The motorcycle has uniform acceleration of <math>80 \text{ km/h}^2</math>. The speed-time graphs of Mr Chan and Mr Lim are shown in the diagram.</p> 	
9ai	<p>Find the speed of the car at 0715 h.</p> $\frac{50-s}{\left(\frac{15}{60}\right)} = \frac{30}{\left(\frac{20}{60}\right)}$ $s = \frac{55}{2} = 27\frac{1}{2} \text{ km/h}$ 	[2]

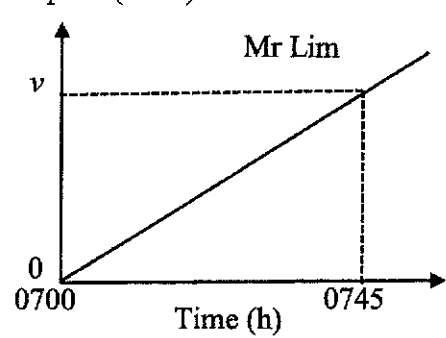
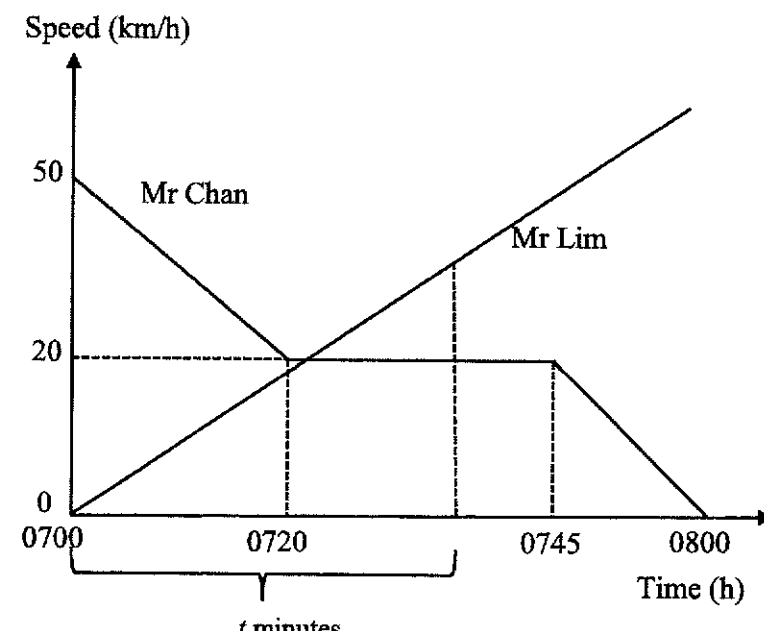
9ai i	Find the speed of the motorcycle at 0745 h.	[1]
<div style="display: flex; justify-content: space-between; align-items: center;"> <div style="width: 30%;"> <math display="block">\frac{v-0}{\left(\frac{45}{60}\right)} = 80</math> <math display="block">v = 60 \text{ km/h}</math> </div> <div style="width: 60%; text-align: center;">  </div> </div>		
9ai ii	Find the time, to the nearest minute, the motorcycle overtakes the car, given that it was between 0720 h and 0745 h	[4]
<p>Let <math>t</math> minutes be the time taken by Mr. Lim to overtake Mr. Chan</p> <div style="display: flex; justify-content: center; align-items: center;">  </div> <p>Distance travelled by Mr Chan from 0700 to 0720</p> $= \frac{1}{2} (50 + 20) \times \frac{20}{60} = \frac{35}{3} \text{ km}$ <p>Distance travelled by Mr Chan from 0720 until overtaken</p> $= \left(\frac{t-20}{-60}\right) \times 20 = \frac{t-20}{-3} \text{ km}$ <p>Distance travelled by Mr Lim from 0700 until overtaking Mr Chan</p> $= \frac{1}{2} \times \frac{t}{60} \times \left(80 \times \frac{t}{60}\right) = \frac{t^2}{90} \text{ km}$		

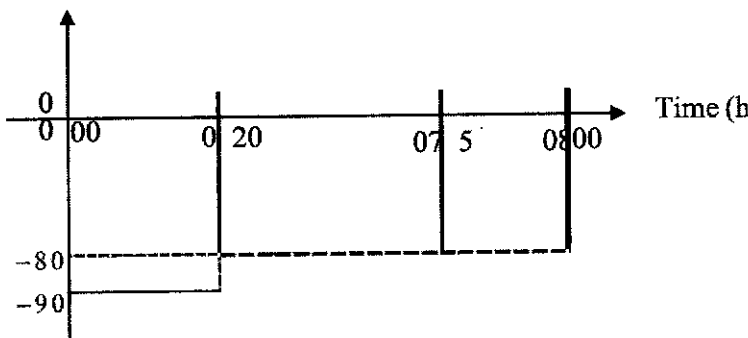
	<p>At the overtaking time, Distance travelled by Mr Chan = Distance travelled by Mr Lim</p> $\frac{35}{3} + \frac{t-20}{3} = \frac{t^2}{90}$ $t^2 = 90 \left( \frac{35}{3} + \frac{t-20}{3} \right)$ $= 1050 + 30t - 600$ $t^2 - 30t - 450 = 0$ $t = \frac{-(-30) \pm \sqrt{(-30)^2 - 4(1)(-450)}}{2(1)}$ $= 40.9808 \quad \text{or} \quad -10.9808(\text{NA})$ <p>The time is 0741 h.</p>	
	<p><b>9b</b> Sketch the acceleration time graph for Mr. Chan.</p>	[2]
	<p>Acceleration from 0700 to 0720 = <math>\frac{50-20}{\frac{20}{60}} = -90 \text{ km/h}^2</math></p> <p>Acceleration from 0745 to 0800 = <math>\frac{20-0}{\frac{15}{60}} = -40 \text{ km/h}^2</math></p> <p>Acceleration (km/h<sup>2</sup>)</p> 	
10	<p>The diagram below shows a rectangle with breadth <math>(x+15)</math> cm. The circle with centre at <math>A</math> has a radius of 10 cm. The semicircle with centre at <math>B</math> and the semicircle with centre <math>C</math> are congruent and each has a radius of <math>x</math> cm. The small circle with centre <math>A</math> touches the semicircles at point <math>D</math> and <math>E</math>. The line <math>AO</math> bisects the length of the rectangle and is a tangent to both of the semicircles.</p>	cm

	<p>Page 11</p>	
<b>10a</b>	Write down an expression, in terms of $x$ , for the length $AC$ .	[1]
	$AC = (x+10)\text{cm}$	
<b>10b</b>	Write down an expression, in terms of $x$ , for the length $OA$ .	[1]
	$OA = (x+15) - 10$ $OA = (x+5)\text{ cm}$	
<b>10c</b>	Hence, write down an equation and show that it simplifies to $x^2 - 10x - 75 = 0$ .	[3]
	$AC^2 = OA^2 + OC^2$ $(x+10)^2 = (x+5)^2 + x^2$ $x^2 + 20x + 100 = x^2 + 10x + 25 + x^2$ $-x^2 + 10x + 75 = 0$ $x^2 - 10x - 75 = 0$	
<b>10d</b>	Solve the equation $x^2 - 10x - 75 = 0$ .	[2]
	$x^2 - 10x - 75 = 0$ $(x-15)(x+5) = 0$ $x = 15$ or $x = -5$	
<b>10e</b>	Hence, find the shaded area.	[2]
	Shaded area = $\pi R^2 + \pi r^2 = \pi(15^2 + 10^2)$ $\approx 1021.01$ $\approx 1020\text{ cm}^2$	
<b>11</b>	A couple intends to purchase a HDB flat and they intend to take a loan from a financial institution. The formula to calculate the monthly mortgage payment is given by	

	$M = \frac{P \left( \frac{i}{100} \left( 1 + \frac{i}{100} \right)^n \right)}{\left( \left( 1 + \frac{i}{100} \right)^n - 1 \right)}$ <p>Where <math>M</math> is the monthly mortgage payment, <math>P</math> is the principal loan amount, <math>i</math> is the monthly interest rate, and <math>n</math> is the number of months required to repay the loan.          (Source: <a href="https://www.businessinsider.com/personal-finance/how-to-calculate-mortgage-payment#:~:text=If%20you%20want%20to%20do,0.04%2F12%20%3D%200.0033">https://www.businessinsider.com/personal-finance/how-to-calculate-mortgage-payment#:~:text=If%20you%20want%20to%20do,0.04%2F12%20%3D%200.0033</a>)</p>									
<p><b>11 a</b></p>	<p>If the couple takes a \$100000 loan to be repaid in 10 years, find the total interest paid as a percentage of the loan, assuming an interest rate of 2% per annum.</p>	<p>[3]</p>								
	<p><math>P = 100000 \quad i = \frac{2}{12} = \frac{1}{6} \quad n = 10 \times 12 = 120</math></p> $M = \frac{P \left( \frac{i}{100} \left( 1 + \frac{i}{100} \right)^n \right)}{\left( \left( 1 + \frac{i}{100} \right)^n - 1 \right)}$ $= \frac{100000 \left( \frac{1}{600} \left( 1 + \frac{1}{600} \right)^{120} \right)}{\left( \left( 1 + \frac{1}{600} \right)^{120} - 1 \right)}$ <p><math>= 920.1345 = \\$920.13</math></p>									
<p><b>11 b</b></p>	<p>The couple intends to take a loan from a financial institution. so they will need to pay 25% of the price as down payment. For the down-payment, they intend to pay up to \$50000.</p> <p>An online search yielded information in the tables below.</p> <p style="text-align: center;"><b>2021 Property Prices in Singapore</b></p> <table border="1" data-bbox="316 1646 1114 1908"> <thead> <tr> <th>Type</th> <th>HDB BTO Flats (Non-Mature Estates)</th> <th>HDB BTO Flats (Mature Estates)</th> <th>Resale Flats</th> </tr> </thead> <tbody> <tr> <td>Two-Room (Flexi)</td> <td>\$90,000 to \$162,000</td> <td>\$137,000 to \$277,000</td> <td>—</td> </tr> </tbody> </table>	Type	HDB BTO Flats (Non-Mature Estates)	HDB BTO Flats (Mature Estates)	Resale Flats	Two-Room (Flexi)	\$90,000 to \$162,000	\$137,000 to \$277,000	—	<p>[3]</p>
Type	HDB BTO Flats (Non-Mature Estates)	HDB BTO Flats (Mature Estates)	Resale Flats							
Two-Room (Flexi)	\$90,000 to \$162,000	\$137,000 to \$277,000	—							



Three-Room	\$164,000 to \$248,000	\$205,000 to \$421,000	\$350,000 to \$380,000
Four-Room	\$253,000 to \$381,000	\$311,000 to \$617,000	\$420,000 to \$550,000
Five-Room	\$405,000 to \$516,000	\$423,000 to \$725,000	\$520,000 to \$700,000

Source: <https://www.singsaver.com.sg/blog/costs-of-bto-flat-resale-flat-ec-and-condo-in-singapore>



(Source: <https://www.hdb.gov.sg/residential/buying-a-flat/resale/getting-started/types-of-flats>)  
Determine all the types of flats that the couple can consider purchasing.

**25% of the 2021 Property Prices in Singapore**

Two-Room (Flexi)	\$22,500 to \$40,500	\$34,250 to \$69,250	
Three-Room	\$41,000 to \$62,000	\$51,250 to \$105,250	Past the \$50000 limit
Four-Room	Past the \$50000 limit	Past the \$50000 limit	Past the \$50000 limit

From the table, the following flats are within the couple's means:

1. HDB BTO Flats (Non-Mature Estates) Two-Room (Flexi),
2. Some HDB BTO Flats (Mature Estates) Two-Room (Flexi) in the lower price range
3. Some HDB BTO Flats (Non-Mature Estates) Three-Room in the lower price range.

	<p>Alternatively, since 25% is \$50000, the full price is budgeted at \$200000.</p> <p>From the table, the following flats are within the couple's means:</p> <ol style="list-style-type: none"> <li>1. HDB BTO Flats (Non-Mature Estates) Two-Room (Flexi),</li> <li>2. Some HDB BTO Flats (Mature Estates) Two-Room (Flexi) in the lower price range</li> <li>3. Some HDB BTO Flats (Non-Mature Estates) Three-Room in the lower price range.</li> </ol>	
<b>11c</b>	<p>Based on the information given in the tables only, give the type of flat that gives the best value for the money spent. State one assumption that the couple could have made.</p>	[3]
	<p>Since there is a range of prices, use the midpoint for each range to calculate price per sq m.</p> <ol style="list-style-type: none"> <li>1. HDB BTO Flats (Non-Mature Estates) Two-Room (Flexi), Midpoint = \$126000, For 36 sq m, price per sq m is <math>\\$126000 / 36 = \\$3500</math> For 45 sq m, price per sq m is <math>\\$126000 / 45 = \\$2800</math></li> <li>2. HDB BTO Flats (Mature Estates) Two-Room (Flexi) Midpoint = \$207000, For 36 sq m, price per sq m is <math>\\$207000 / 36 = \\$5750</math> For 45 sq m, price per sq m is <math>\\$207000 / 45 = \\$4600</math></li> <li>3. HDB BTO Flats (Non-Mature Estates) Three-Room in the lower price range Midpoint = \$206000. Midpoint = 62.5 sq m Price per sq m is <math>\\$206000 / 62.5 = \\$3296</math></li> </ol> <p>Based on the price per sq m criterion, the first choice is a HDB BT Flats (Non-Mature Estates) Two-Room (Flexi) 45 sq m.</p>	
	OR	
	<ol style="list-style-type: none"> <li>4. HDB BTO Flats (Non-Mature Estates) Two-Room (Flexi), For 36 sq m, price per sq m is \$2500 to \$4500 For 45 sq m, price per sq m is \$2000 to \$3600</li> <li>5. Some HDB BTO Flats (Mature Estates) Two-Room (Flexi) in the lower price range For 36 sq m, price per sq m is \$3805.56 to \$7694.44 For 45 sq m, price per sq m is \$3044.44 to \$6155.56</li> <li>6. Some HDB BTO Flats (Non-Mature Estates) Three-Room in the lower price range For 60 sq m, price per sq m is \$2733.33 to \$4133.33 For 65 sq m, price per sq m is \$2523.08 to \$3815.38</li> </ol>	

	Based on the price per sq m criterion, the first choice is a HDB BT Flats (Non-Mature Estates) Two-Room (Flexi) 45 sq m in the low price range.															
	<p>Assumption, only one is needed:</p> <ol style="list-style-type: none"> <li>The prices of the different types of housing remains stable regardless of region.</li> <li>All the different types of flats are available.</li> <li>Without detailed information, the couple assumes that for each floor area, there can be the full range of prices, e.g. for a 45 m<sup>2</sup> flat, the prices can range from \$90,000 to \$162,000.</li> <li>Without detailed information, either the range of minimum to maximum, or the midpoint can be used for calculation.</li> </ol> <p>In each category, the lowest price corresponds to the smallest floor area, and the higher price corresponds to the larger floor area.</p>															
12	<p>The variables of <math>x</math> and <math>y</math> are connected by the equation</p> $y = \frac{x^2}{6} + \frac{2}{x} - 3.$ <p>Some corresponding values of <math>x</math> and <math>y</math>, correct to two decimal places, are given in the table below.</p> <table border="1"> <tr> <td><math>x</math></td> <td>0.5</td> <td>1</td> <td>1.5</td> <td>2</td> <td>2.5</td> <td>3</td> </tr> <tr> <td><math>y</math></td> <td><math>p</math></td> <td>-0.83</td> <td>-1.29</td> <td>-1.33</td> <td>-1.16</td> <td>-0.83</td> </tr> </table>	$x$	0.5	1	1.5	2	2.5	3	$y$	$p$	-0.83	-1.29	-1.33	-1.16	-0.83	
$x$	0.5	1	1.5	2	2.5	3										
$y$	$p$	-0.83	-1.29	-1.33	-1.16	-0.83										
12 a	Find the value of $p$ .	[1]														
	<p>Sub <math>x = 0.5</math> and <math>y = p</math> into <math>y = \frac{x^2}{6} + \frac{2}{x} - 3</math></p> $p = \frac{0.5^2}{6} + \frac{2}{0.5} - 3 \approx 1.04$															
12 b	<p>Use a scale of 2 cm to represent 1 unit, draw a horizontal <math>x</math>-axis from <math>0 \leq x \leq 6</math>. Use a scale of 4 cm to represent 1 unit, draw a vertical <math>y</math>-axis from <math>-2 \leq y \leq 4</math>.</p> <p>On your axes, plot the points given in the table and join them with a smooth curve.</p>	[3]														

<b>12c</b>	Use your graph to find the solutions of $\frac{x^2}{6} + \frac{2}{x} - 2 = 0$ .	[2]								
	$\frac{x^2}{6} + \frac{2}{x} - 2 = 0$ $\frac{x^2}{6} + \frac{2}{x} - 2 - 1 = 0 - 1$ $\frac{x^2}{6} + \frac{2}{x} - 3 = -1$ $y = -1$ <p>From the graph, when <math>y = -1</math>,  <math>x \approx 1.116(\pm 0.2)</math> or <math>x \approx 2.769(\pm 0.2)</math></p>									
<b>12d</b>	By drawing a tangent, find the gradient of the curve at $(3, -0.83)$ .	[2]								
	<p>Draw a tangent at <math>(3, -0.83)</math></p> <p>Therefore gradient <math>\approx 0.878 \pm 0.2</math></p>									
<b>12e i</b>	On the same axes, draw the line of with gradient $-0.5$ that passes through the point with coordinates $(4, -1)$ .	[1]								
	<table border="1" style="margin-left: auto; margin-right: auto;"> <tbody> <tr> <td><math>x</math></td> <td>0</td> <td>1</td> <td>3</td> </tr> <tr> <td><math>y = -0.5</math></td> <td>0</td> <td>-0.5</td> <td>-1</td> </tr> </tbody> </table> 	$x$	0	1	3	$y = -0.5$	0	-0.5	-1	
$x$	0	1	3							
$y = -0.5$	0	-0.5	-1							

B1 for two parallel lines (one is $y = -0.5x$ and the other is parallel to $y = -0.5x$ and pass through $(4, -1)$ )		
<b>12e</b> <b>ii</b>	Write down the equation of this line.	[1]
	From the graph, $y = -0.5x + 1$	
<b>12e</b> <b>iii</b>	Write down the $x$ -coordinates of the points where the line intersects the curve.	[2]
	$x \approx 0.544(\pm 0.2)$ or $x \approx 3.29(\pm 0.2)$	
<b>12e</b> <b>iv</b>	These values of $x$ are the solutions of the equation $x^3 + Ax^2 - 24x + B = 0$ . Find the value of $A$ and of $B$ .	[2]
	<p>The values of <math>x</math> are the solutions for the pair of simultaneous equations</p> $y = \frac{x^2}{6} + \frac{2}{x} - 3 \text{ and } y = -0.5x + 1$ $\frac{x^2}{6} + \frac{2}{x} - 3 = -0.5x + 1$ $x^3 + 12 - 18x = -3x^2 + 6x$ $x^3 + 12 - 18x + 3x^2 - 6x = 0$ $x^3 + 3x^2 - 24x + 12 = 0$ <p>Therefore <math>A = 3</math> and <math>B = 12</math></p>	<p style="text-align: center;">— —</p> <p style="text-align: right;">2 x — 3</p>

