

NAME:	()
-------	-----

CLASS:	
--------	--



YISHUN TOWN SECONDARY SCHOOL



PRELIMINARY EXAMINATION 2020 SECONDARY 4 EXPRESS / 5 NORMAL ACADEMIC MATHEMATICS PAPER 1 (4048/01)

DATE : 27 AUGUST 2020

DAY : Thursday

DURATION : 2 h

MARKS : 80

READ THESE INSTRUCTIONS FIRST

Do not turn over the cover page until you are told to do so.
Write your name, class and class index number in the spaces at the top of this page.
Write in dark blue or black pen.
You may use a pencil for any diagrams or graphs.
Do not use staples, paper clips, highlighters, glue or correction fluid.

Answer all the questions.
Give non-exact numerical answers correct to 3 significant figures, or 1 decimal place in the case of angles in degrees, unless a different level of accuracy is specified in the question.
The use of an approved scientific calculator is expected, where appropriate.
For π , use either your calculator value or 3.142, unless the question requires the answer in terms of π .

You are reminded of the need for clear presentation in your answers.

At the end of the examination, fasten all your work securely together.

The number of marks is given in brackets [] at the end of each question or part question.

The total marks for this paper is 80.

	MARKS	
	OBTAINED	FULL
1		2
2		3
3		2
4		2
5		3
6		4
7		2
8		2
9		3
10		3
11		3
12		2
13		3
14		2
15		3
16		5
17		5
18		5
19		4
20		5
21		8
22		4
23		5
TOTAL		80

This question paper consists of 17 printed pages and 1 blank page.

Mathematical Formulae*Compound interest*

$$\text{Total amount} = P \left(1 + \frac{r}{100} \right)^n$$

Mensuration

$$\text{Curved surface area of a cone} = \pi r l$$

$$\text{Surface area of a sphere} = 4\pi r^2$$

$$\text{Volume of a cone} = \frac{1}{3} \pi r^2 h$$

$$\text{Volume of a sphere} = \frac{4}{3} \pi r^3$$

$$\text{Area of triangle } ABC = \frac{1}{2} ab \sin C$$

$$\text{Arc length} = r\theta, \text{ where } \theta \text{ is in radians}$$

$$\text{Sector area} = \frac{1}{2} r^2 \theta, \text{ where } \theta \text{ is in radians}$$

Trigonometry

$$\frac{a}{\sin A} = \frac{b}{\sin B} = \frac{c}{\sin C}$$

$$a^2 = b^2 + c^2 - 2bc \cos A$$

Statistics

$$\text{Mean} = \frac{\sum fx}{\sum f}$$

$$\text{Standard deviation} = \sqrt{\frac{\sum fx^2}{\sum f} - \left(\frac{\sum fx}{\sum f} \right)^2}$$

Answer **all** the questions.

- 1 (a) Write down all the irrational numbers.

$$\frac{22}{7}, \quad \frac{\sqrt{2}}{2}, \quad \sqrt[3]{-8}, \quad \pi, \quad -0.\dot{3}$$

Answer [1]

- (b) Calculate $\frac{4.23^3 - 3.4 \div 2}{\sqrt{41.35}}$ and write down your answer correct to 1 significant figure.

Answer [1]

- 2 Mrs Tan planned to earn an interest of \$1000 at the end of 5 years by investing her money in a bank. The rate of compound interest was fixed at 1.25% per annum. Find the amount of money she needed to deposit in the bank.

Answer \$ [3]

- 3 The sine of an obtuse angle is $\frac{5}{13}$.
Without the use of a calculator, find the value for the cosine of the same angle.

Answer [2]

4

- 4 The diagram shows a pentagon.
 Three of the interior angles are 100° each.
 One of its exterior angle is 50° .
 Find the value of x .

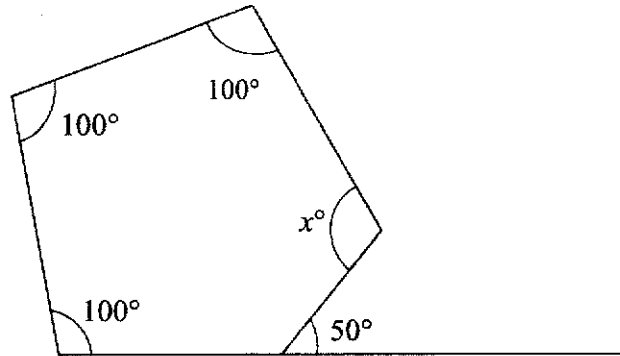

Answer $x = \dots\dots\dots$ [2]

- 5 y is inversely proportional to the square root of x . It is given that $y = 5$ for a certain value of x .
 Find the value of y when x is increased by 300%.

Answer $y = \dots\dots\dots$ [3]

6 $\xi = \{\text{integers } x : 0 < x < 15\}$

$A = \{\text{factors of } 15\}$

$B = \{\text{perfect squares}\}$

(a) Draw a Venn diagram to illustrate this information.

[2]

(b) List the elements contained in the set $A \cap B'$.

Answer [1]

(c) Use one of the symbols below to complete the statement.

$$\emptyset \subset \subsetneq = \in \notin$$

1 $A \cap B$

[1]

7 Box P is 25% heavier than Box Q and Box R is 75% heavier than Box P .
Express the weight of Box R as a percentage of the weight of Box Q .

Answer % [2]

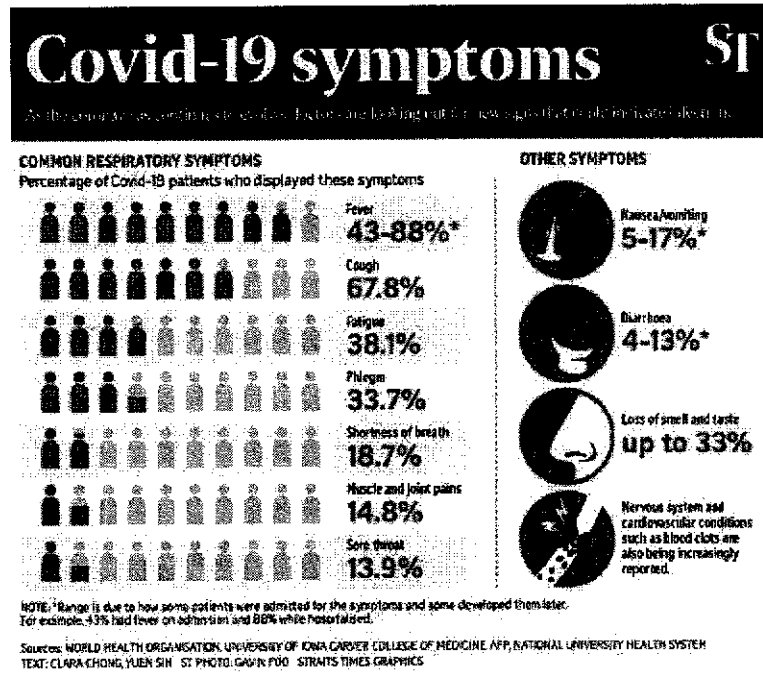

Reference from <https://str.sg/JAoU>

(a) Explain why the total percentage of people who displayed Covid-19 symptoms adds up to more than 100%.

..... [1]

(b) Explain whether it is appropriate to represent the data on a pie chart.

..... [1]

9 Solve the equation $\frac{1}{3}x^2 = 3x$.

Answer $x =$ or [3]

10 Given that $\sqrt{3} \times 27^n = 1$, find the value of n .

Answer $n = \dots\dots\dots$ [3]

11 The CoV (coronavirus) is circular in shape with a diameter of approximately 0.00014 mm.
Express

(a) 0.000 14 in standard form,

Answer $\dots\dots\dots$ [1]

(b) 0.000 14 mm in nanometre.
(1 nanometre = 10^{-9} metre)

Answer $\dots\dots\dots$ nm [2]

12 Solve the inequalities $3x - 1 < 2x + 3 \leq 7 + 5x$.

Answer $\dots\dots\dots$ [2]

- 13 Simplify $\left(\frac{-2p^3}{q^{-1}}\right)^2 \div \left(\frac{8q^0}{p^3}\right)^{\frac{1}{3}}$, giving your answer in positive index form.

Answer [3]

- 14 A group of students recorded the volume of water using a measuring cylinder in an experiment. The mean volume of water recorded was 1.8 cm^3 and the standard deviation was 0.28 cm^3 .

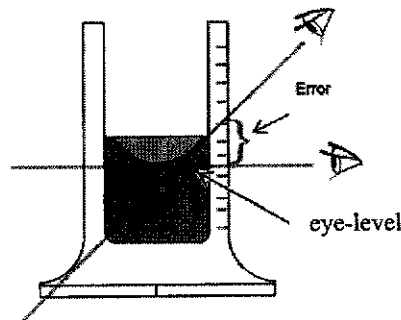

The teacher realized that there was an error in the reading taken by all the students. All the students recorded a reading of 0.6 cm^3 above the correct reading at eye-level. Explain how the correct mean volume of water and standard deviation was affected by the error.

.....
 [2]

- 15 (a) Express 1728 as a product of its prime factors in index notation.

Answer [1]

- (b) Using your answer in part (a), explain why 1728 is a perfect cube.

Answer [1]

- (c) k is a prime number. Find the value of k such that $\frac{1728}{k}$ is a perfect square.

Answer $k =$ [1]

- 16 In a sequence, each term is obtained by adding the same number from the previous term.
The first four terms in a sequence are 36, p , q , 93.

- (a) Find the value of p , and q .

Answer $p =$

$q =$ [2]

- (b) Find an expression, in terms of n , for the n th term T_n , of this sequence.

Answer $T_n =$ [1]

- (c) Explain why 225 cannot be a term of this sequence.

.....

..... [2]

17 The line $3x - 5y = 10$ passes through the point A at $(5, 1)$ and cuts the y -axis at point B .

(a) Write down the gradient of the line.

Answer [1]

(b) Find the length of AB .

Answer units [2]

(c) C is a point $(0, k)$ and the area of triangle ABC is 10 units^2 .
Find the possible value(s) of k .

Answer $k = \dots\dots\dots$ or $\dots\dots\dots$ [2]

18 An area of 324 cm^2 on a map represents an area of 20.25 km^2 .

- (a) A resort has an actual area of 81 km^2 .
Find the area, in square centimetres, of the resort on the map.

Answer cm^2 [2]

- (b) The distance between two schools on the map is 54 cm .
Find the actual distance, in kilometres, between the two schools.

Answer km [2]

- (c) The scale on the map can be expressed as $1 : n$.
Find the value of n .

Answer $n =$ [1]

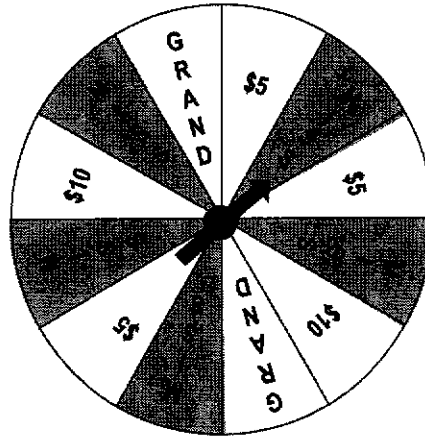

The diagram shows a lucky draw spinner at a departmental store. The pointer is equally likely to stop at any of the sectors. The sectors show a GRAND prize, \$5 or \$10 prize vouchers to be won or a MISS. Each customer at the store is entitled to 1 spin for every \$50 spent.

- (a) Find the probability that a customer wins the grand prize in a spin.

Answer [1]

- (b) Find the probability that a customer wins a \$5 or a \$10 voucher in a spin.

Answer [1]

- (c) Mrs Singh spends \$120 at the store.
Find, as a fraction in its simplest form, the probability that she wins at least a prize.

Answer [2]

- 20 The graphs of $y = a(x+2)(4-x)$ and $y = -\frac{1}{2}x + \frac{5}{2}$ are drawn on the grid.

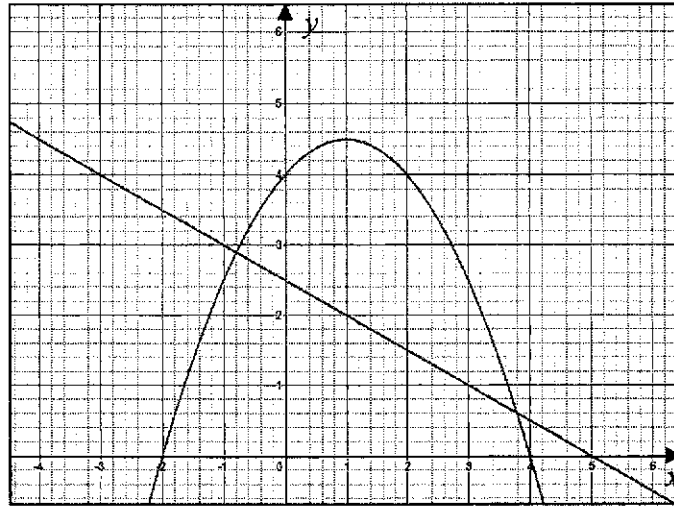

- (a) Write down the equation of the line of symmetry of the curve.

Answer [1]

- (b) Show that the value of $a = \frac{1}{2}$.

Answer
 [1]

- (c) Explain why the equation $a(x+2)(4-x) = k$ does not have solutions for some values of k .

Answer
 [1]

- (d) The points of intersection of the curve and the straight line give the solutions of a quadratic equation. Find the quadratic equation, giving your answer in the form $x^2 + px + q = 0$.

Answer [2]

21

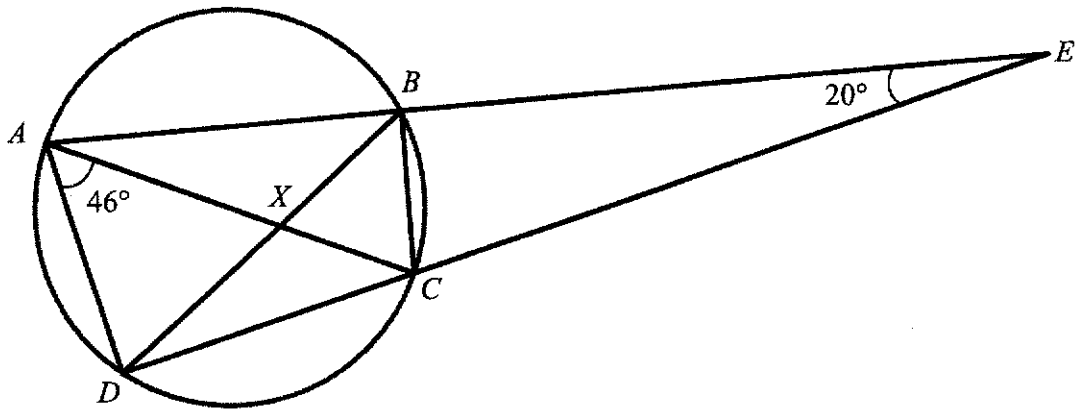

In the diagram, AC is a diameter of the circle $ABCD$.
 AB and DC are produced to meet at E .
 Angle $AED = 20^\circ$ and angle $CAD = 46^\circ$.

(a) Find, giving reasons for each answer,

(i) angle ABC ,

Answer $^\circ$ [1]

(ii) angle BCE ,

Answer $^\circ$ [1]

(iii) angle BAC ,

Answer $^\circ$ [2]

- (b) AC and BD intersect at X . Showing your calculations clearly, explain why X is not the centre of the circle.

Answer

- (c) Determine whether a semicircle can be drawn passing through the points B, C, E .

[3]

Answer

[1]

16

- 22 (a) Construct triangle ABC where AC is 10 cm and angle $BAC = 40^\circ$.
 AB has already been drawn.

[1]

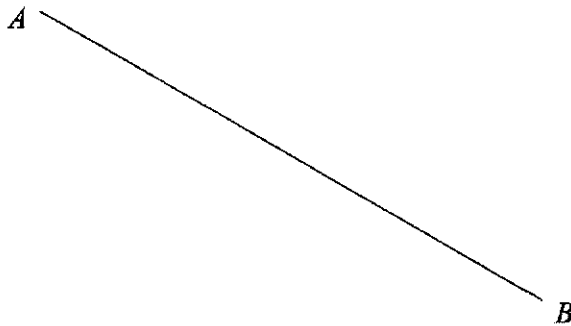

- (b) Construct
- (i) the perpendicular bisector of AB , [1]
 - (ii) the angle bisector of angle BAC . [1]
- (c) Mark clearly a possible point which is inside triangle ABC , equidistant from A and B , and is nearer to AC than to AB .
Label this point P . [1]
-

- 23 The diagram show the speed-time graph of a car's journey between two road junctions. The shaded area represents the distance travelled. The distance travelled is 1620 m.

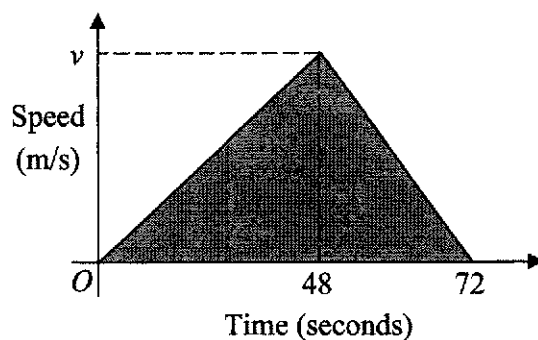

- (a) Calculate the greatest speed, v m/s of the car.

Answer m/s [2]

- (b) Calculate the speed of the car after 32 seconds.

Answer m/s [2]

- (c) Calculate the deceleration of the car for the last 24 seconds of the journey.

Answer m/s^2 [1]

END OF PAPER

BLANK PAGE

NAME:		()
-------	--	-----

CLASS:	
--------	--



YISHUN TOWN SECONDARY SCHOOL



PRELIMINARY EXAMINATION 2020 SECONDARY 4 EXPRESS / 5 NORMAL ACADEMIC MATHEMATICS PAPER 2 (4048/02)

DATE : 31 August 2020

DAY : Monday

DURATION: 2 h 30 min

MARKS: 100

READ THESE INSTRUCTIONS FIRST

Do not turn over the cover page until you are told to do so.
Write your name, class and class index number in the spaces at the top of this page.
Write in dark blue or black pen.
You may use a pencil for any diagrams or graphs.
Do not use staples, paper clips, highlighters, glue or correction fluid.

Answer **all** the questions.
Give non-exact numerical answers correct to 3 significant figures, or 1 decimal place in the case of angles in degrees, unless a different level of accuracy is specified in the question.
The use of an approved scientific calculator is expected, where appropriate.
For π , use either your calculator value or 3.142, unless the question requires the answer in terms of π .

You are reminded of the need for clear presentation in your answers.

At the end of the examination, fasten all your work securely together.

The number of marks is given in brackets [] at the end of each question or part question.

The total marks for this paper is 100.

	MARKS	
	OBTAINED	FULL
1		8
2		10
3		9
4		12
5		11
6		9
7		9
8		12
9		10
10		10
TOTAL		100

This question paper consists of 19 printed pages including this cover page and 1 blank page

Mathematical Formulae*Compound Interest*

$$\text{Total amount} = P \left(1 + \frac{r}{100} \right)^n$$

Mensuration

$$\text{Curved surface area of a cone} = \pi r l$$

$$\text{Surface area of a sphere} = 4\pi r^2$$

$$\text{Volume of a cone} = \frac{1}{3} \pi r^2 h$$

$$\text{Volume of a sphere} = \frac{4}{3} \pi r^3$$

$$\text{Area of a triangle } ABC = \frac{1}{2} ab \sin C$$

$$\text{Arc length} = r\theta, \text{ where } \theta \text{ is in radians}$$

$$\text{Sector area} = \frac{1}{2} r^2 \theta, \text{ where } \theta \text{ is in radians}$$

Trigonometry

$$\frac{a}{\sin A} = \frac{b}{\sin B} = \frac{c}{\sin C}$$

$$a^2 = b^2 + c^2 - 2bc \cos A$$

Statistics

$$\text{Mean} = \frac{\sum fx}{\sum f}$$

$$\text{Standard deviation} = \sqrt{\frac{\sum fx^2}{\sum f} - \left(\frac{\sum fx}{\sum f} \right)^2}$$

3

Answer **all** the questions

- 1 (a) Given that $\frac{5a-3b}{2a} = \frac{4}{3}$, find the value of $\frac{a}{b}$.

Answer [2]

- (b) (i) Express $x^2 - 6x + 1$ in the form $(x+a)^2 + b$.

Answer [1]

- (ii) Hence solve the equation $x^2 - 6x + 1 = 0$, giving your answers correct to two decimal places.

Answer $x = \dots\dots\dots$ or $x = \dots\dots\dots$ [3]

- (c) Given that 4500 workers, each working 8 hours a day, will complete the Thomson Line in 1800 days.
If 4800 workers work on the project with each worker working for 10 hours a day, find the number of days it would take to complete the project.

Answer days [2]

4

- 2 (a) Factorise completely $m^2 - 2mn + n^2 - p^2$.

Answer [2]

- (b) Express as a single fraction in its simplest form $\frac{7}{2x-3} + \frac{x+1}{6-4x}$.

Answer [3]

- (c) It is given that $p = \sqrt{1 + \frac{p^2}{r}}$.

- (i) Find the values of p when $r = 1.125$.

Answer $p = \dots\dots\dots$ or $p = \dots\dots\dots$ [2]

- (ii) Express r in terms of p .

Answer $r = \dots\dots\dots$ [3]

5

- 3 A supermarket sold all of its toilet rolls at a price of \$ x per pack in January. The revenue made from selling the packs of toilet rolls in January was \$5940.

(a) Write down an expression in x , for the number of packets of toilet rolls sold in January.

Answer [1]

In February, the supermarket ordered an additional 600 packs to the number sold in January and sold them at 50 cents more per pack.

(b) Write down an expression in x , for the total amount of money received in dollars, if all the packs of toilet rolls were sold in February.

Answer \$ [1]

(c) The supermarket received \$3870 more from the sales of toilet rolls in February as compared to January.

Write down an equation in x to represent this information, and show that it reduces to

$$20x^2 - 119x + 99 = 0.$$

Answer

[3]

(d) Solve the equation $20x^2 - 119x + 99 = 0$.

Answer $x = \dots\dots\dots$ or $x = \dots\dots\dots$ [3]

(e) If each pack of toilet rolls was sold for more than \$1, find the number of packs of toilet rolls sold by the supermarket in February.

Answer packets [1]

7

- (b)** The selling price of a laptop is \$2675.
A student can buy this laptop at a discounted price of \$2140.
- (i)** Calculate the percentage discount given for student price.

Answer % [2]

- (ii)** The student price of \$2140 is inclusive of 7% Goods and Services Tax (GST).
Calculate the student price of the laptop before GST.

Answer [2]

- (iii)** A student decides to buy this laptop on hire purchase.
The cash price of the laptop is \$2140.
The student pays a deposit of 10% of the cash price and makes 36 equal monthly payments.
At the end of the 36 months, the total hire purchase price of the laptop is \$2500.
Calculate the amount of monthly payment.

Answer \$ [3]

- 5 The variables x and y are connected by the equation $y = 2x^3 - 21x^2 + 54x$.

Some corresponding values of x and y are given in the table below.

x	0	0.5	1	2	3	4	4.5	5	6
y	0	22	35	40	27	8	p	-5	0

- (a) Find the value of p .

Answer [1]

- (b) On the grid opposite, plot the points given in the table and join them with a smooth curve. [3]

- (c) Use your graph to estimate the maximum value and the minimum value of y for $0 \leq x \leq 6$.

Answer Maximum $y =$

Minimum $y =$ [2]

- (d) By drawing a tangent, find the gradient of the curve at (0.5, 22).

Answer [2]

- (e) (i) On the same axes, draw the line $y = 45 - 6x$ for $0 \leq x \leq 6$. [1]

- (ii) Write down the x -coordinates of the points where the line intersects the curve.

Answer $x =$, $x =$ [2]

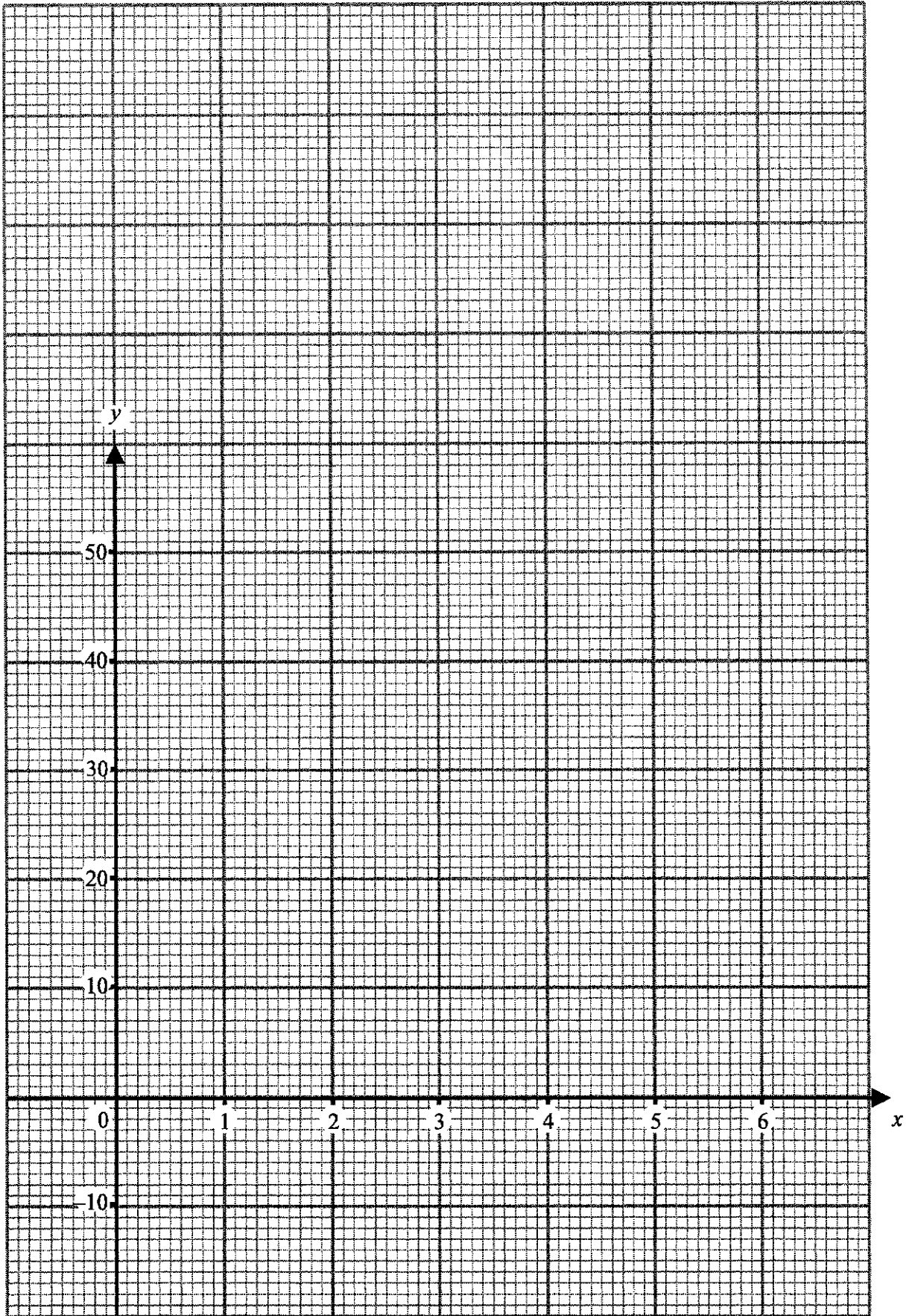

- 6 $ABCD$ is a trapezium.
 F is a point on CD such that $ABCF$ is a rhombus and $3AE = 2EF$.

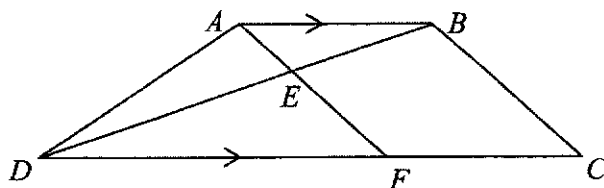

- (a) Show that triangles ABE and FDE are similar.
 Give a reason for each statement you make.

Answer

[2]

- (b) Given that $AB = 8$ cm, find CD .

Answer cm [2]

- (c) Find the area of triangle ABE if the area of triangle FDE is 54 cm².

Answer cm² [2]

- (d) Find $\frac{\text{area of triangle } ADE}{\text{area of triangle } ABE}$.

Answer [1]

- (e) Find $\frac{\text{area of triangle } ABE}{\text{area of triangle } ADF}$.

Answer [2]

7

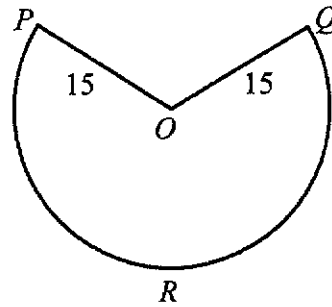

The diagram shows a cardboard in the shape of a major sector, centre O and radius 15 cm. The total area of the major sector $OPRQ$ is 450 cm^2 .

(a) Calculate reflex angle POQ in radians.

Answer radians [2]

(b) Calculate the perimeter of the cardboard.

Answer cm [2]

13

(c)

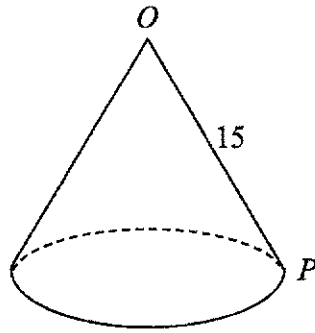

OP and OQ is joined together such that the cardboard forms a conical party hat.

(i) Find the height of the hat.

Answer cm [3]

(ii) Calculate the volume of the cone.

Answer cm^3 [2]

8

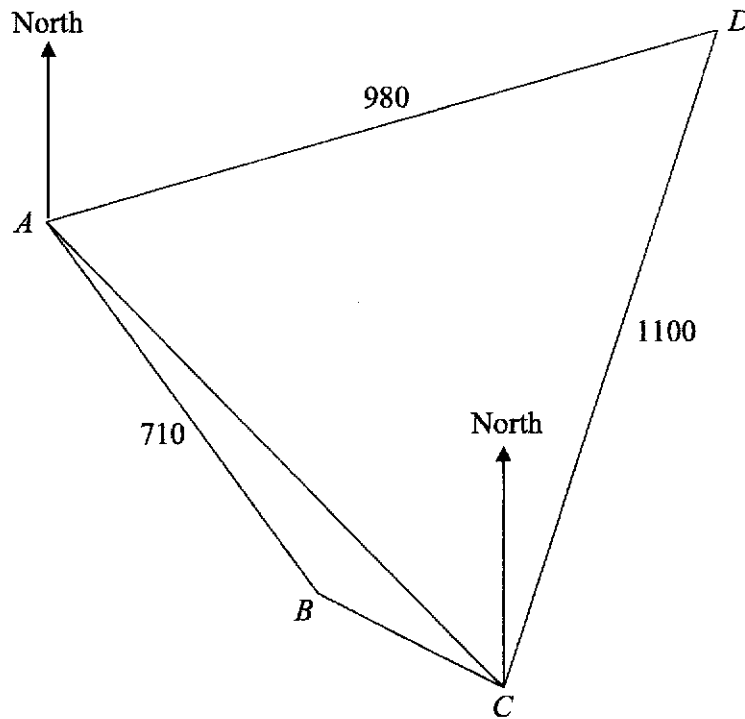

Points A , B , C and D are at sea level.

$AD = 980$ km, $AB = 710$ km and $CD = 1100$ km.

The bearing of B and C from A are 148° and 140° respectively.

The bearing of B and D from C are 300° and 016° respectively.

(a) Show that angle $ACB = 20^\circ$.

[2]

(b) Calculate AC .

Answer km [3]

15

- (c) Calculate the bearing of A from D .

Answer ° [3]

- (d) A ship travels in a straight line from A to C .
Calculate the shortest distance of the ship from B during the journey.

Answer km [2]

- (e) A plane is at a height of 900 metres above the sea.
The angle of depression of C from the plane is 18° .
Calculate the horizontal distance, in kilometres, between the plane and C .

Answer km [2]

- 9 The temperatures of eighteen girls in a class on a particular day are shown in the stem-and-leaf diagram.

35	4	4	7	7	9	
36	1	2	4	4	5	
36	6	7	7	7	8	9
37	1	x				

Key: 37 | 1 represents 37.1 °C

- (a) Given that the range is 1.8 °C, find the value of x .

Answer $x =$ [1]

- (b) The temperatures can be represented on a box-and-whisker plot.

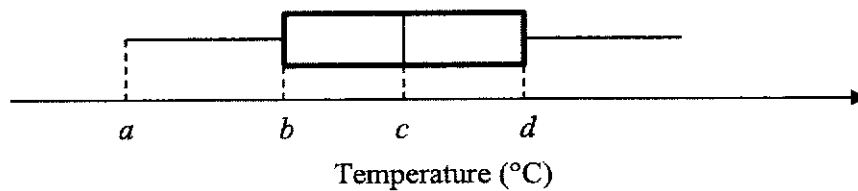

- (i) Calculate the values of a , b , c and d .

Answer $a =$

$b =$

$c =$

$d =$ [4]

- (ii) Find the interquartile range.

Answer °C [1]

(c) (i) Calculate the mean temperature.

Answer °C [1]

(ii) Find the standard deviation of the temperatures.

Answer °C [1]

(d) Information on the temperatures of eighteen boys in a class on that same particular day is shown below.

<p>Mean temperature = 36.0 °C Standard Deviation = 0.294 °C</p>

Make two comments comparing the temperatures of the girls and boys.

1

.....

2

..... [2]

- 10 Julian owns a fruit stall selling fruit juice.

The tables below give information related to Julian's stall.

Information on some of the fruits available		
Type of Fruit	Volume of Juice per fruit (millilitres)	Amount of Sugar per fruit (grams)
Apple	75	19
Orange	75	14
Pears	90	17
Pineapple	630	89
Watermelon	1890	280

Additional Information
Capacity of a cup – 300 ml
Number of ice cubes used in a cup – 6 cubes
Dimensions of an ice cube – approximate 2 cm × 2 cm × 1.5 cm

- (a) Calculate the volume of ice, in cm^3 , used in each cup of juice sold at the stall.

Answer cm^3 [1]

- (b) Estimate the amount of sugar content, in grams, in 1 cup of apple juice with ice.

Answer g [2]

BLANK PAGE

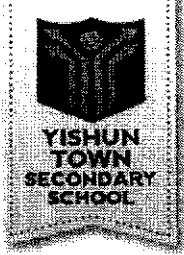

YISHUN TOWN SECONDARY SCHOOL
2020 PRELIMINARY EXAMINATION
Secondary Four Express / 5 Normal
MATHEMATICS

4048/01

Answer Key

Qn	Answer	Qn	Answer
1(a)	$\frac{\sqrt{2}}{2}, \pi$	1(b)	10
2	$P = \$15604.97$	3	$-\frac{12}{13}$
4	$x = 110$	5	$2\frac{1}{2}$
6(i)	ξ	6(ii)	$A' = \{3, 5\}$
6(iii)	\in	7	218.75%
8(i)	There are people with more than 1 type of symptoms.	8(ii)	No, since the total percentage does not add up to 100%.
9	$x = 0$ or $x = 9$	10	$n = -\frac{1}{6}$
11(a)	1.4×10^{-4}	11(b)	140 nm
12	$-\frac{4}{3} \leq x < 4$	13	$2p^7q^2$
14	The correct mean volume is 0.6 cm^3 less (1.2 cm^3) and the standard deviation remains unchanged.	15(a)	$1728 = 2^6 \times 3^3$
15(b)	The powers of the bases are multiple of 3. Hence 1728 is a perfect cube.	15(c)	$k = 3$
16(a)	$p = 55$ $q = 74$	16(b)	$T_n = 17 + 19n$
16(c)	208 is not a multiple of 19 / 208 is not exactly divisible by 19 / n is not a positive integer	17(a)	gradient = $\frac{3}{5}$
17(b)	5.83 units	17(c)	$k = 2$ or $k = -6$
18(a)	1296 cm^2	18(b)	13.5 km
18(c)	$n = 25\ 000$	19(a)	$\frac{1}{6}$
19(b)	$\frac{5}{12}$	19(c)	$\frac{119}{144}$
20(a)	45 m/s	20(b)	30 m/s
20(c)	$1\frac{7}{8}$	21(a)	$x = 1$
21(b)	$a = \frac{1}{2}$	21(c)	For $k > 4.5$, the line $y = k$ does not intersect the graph.

20

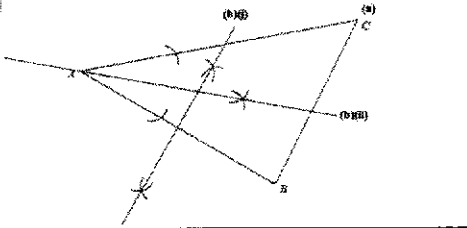
21(d)	$x^2 - 3x - 3 = 0$	22(a)(i)	90°
22(a)(ii)	70°	22(a)(iii)	30°
22(b)	angle $XDA \neq$ angle CAD , hence $AX \neq DX$. AX and DX are not the radii of the circle. (Triangle AXD is not an isosceles triangle.)	22(c)	angle $CBE = 90^\circ$ (rt angle in semicircle) Therefore a circle can be drawn passing through the points B, C, E .
23(a)		23(b)	Shaded region (Bottom left region)

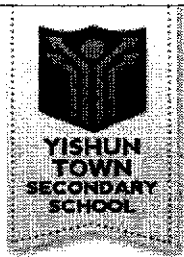

YISHUN TOWN SECONDARY SCHOOL
2020 PRELIMINARY EXAMINATION
 Secondary Four Express / 5 Normal
MATHEMATICS

4048/02

Answer Key

Qn	Answer	Qn	Answer
1a	$\frac{9}{7}$	1bi	$(x-3)^2 - 8$
1bii	5.83, 0.17	1c	1350
2a	$(m-n-p)(m-n+p)$	2b	$\frac{13-x}{2(2x-3)}$
2ci	3 or -3	2cii	$r = \frac{p^2}{p^2-1}$
3a	$\frac{5940}{x}$	3b	$\$ \left(\frac{5940}{x} + 600 \right) (x+0.5)$
3d	4.95, 1	3e	1800
4ai	$\begin{pmatrix} 3.5 \\ 3 \\ 1.5 \end{pmatrix}$	4aii	$\begin{pmatrix} 815 \\ 615 \end{pmatrix}$
4aiii	The elements represents total cost price of hand sanitizers, hand soap and wipes for each pharmacy respectively.	4aiv	(316.75)
4av	The matrix represents the total amount of profit made by both pharmacies.	4bi	20%
4bii	\$2000	4biii	\$63.50
5a	0	5c	Maximum: 41, Minimum: -6
5d	34	5eii	1.2, 3

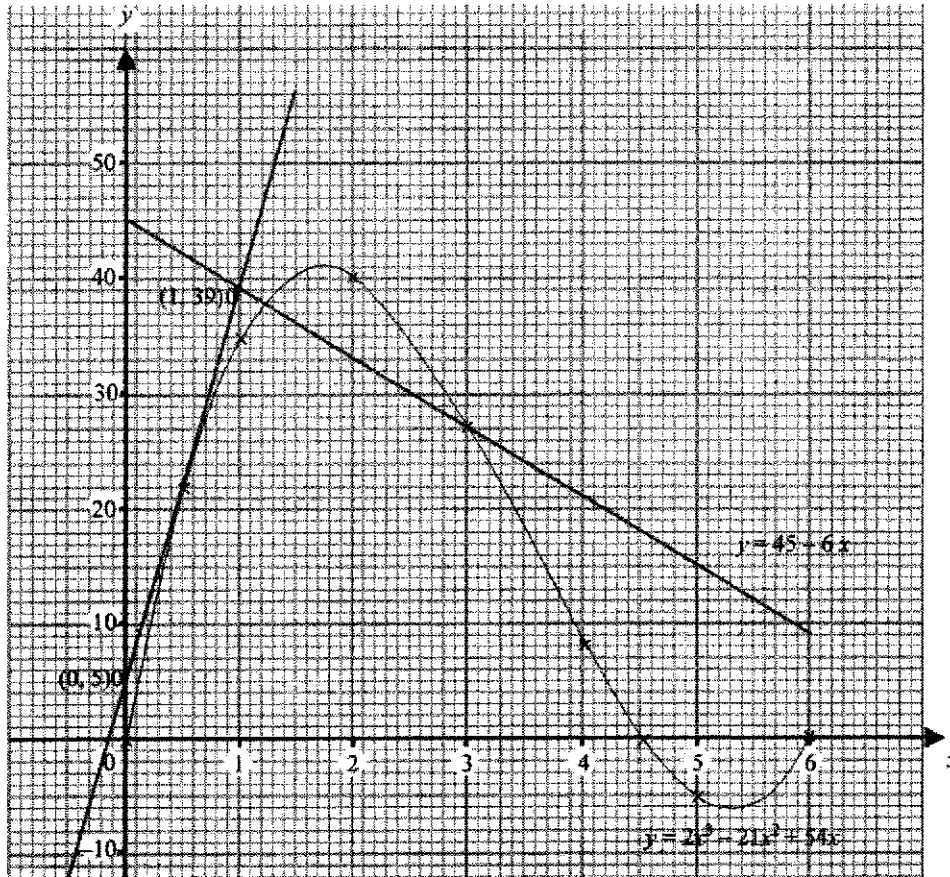

6a	$\angle ABE = \angle FDE$ (alt. \angle s, // lines) $\angle BAE = \angle DFE$ (alt. \angle s, // lines) $\angle BEA = \angle DEF$ (vert. opp. \angle s) By Angle-Angle Similarity Test, triangle ABE and triangle FDE are similar.	6b	20
6c	24	6d	$\frac{3}{2}$
6e	$\frac{4}{15}$	7a	4
7b	90	7ci	11.6
7cii	1100	8b	975
8c	251.5	8d	98.8
8e	2.77	9a	2
9bi	$a = 35.4, b = 35.9, c = 36.45, d = 36.7$	9bii	0.8
9ci	36.4 °C	9cii	0.537 °C
9d	1. The temperatures of the girls are higher than the boys as the mean temperature of the girls is greater than the mean temperature of the boys. 2. The temperatures of the girls are less consistent compared to the boys, since the standard deviation of temperatures is higher.	10a	36

10b	66.88		
10c	<p><u>Amount of sugar per ml of</u></p> <p>Apple: 0.25333g Orange: 0.18667g Pear: 0.18889g Pineapple: 0.14127g Watermelon: 0.14815g</p> <p>Amount of fruit juice used for each fruits = $\frac{264}{3} = 88$ ml</p> <p>Fruits to use: Pineapple, Watermelon and Apple</p> <p>Amount of sugar in the mixed fruit juice = $88 \times (0.14815 + 0.14127 + 0.25333)$ = 47.762g</p> <p>Number of teaspoons = $47.762 \div 5 = 9.5524$</p> <p>As long as Julian uses the fruit with the highest sugar content, his mixed fruit juice will NOT be deemed as healthy. This is because a person may take in sugar in other meals and his mixed fruit juice almost took up 1 day's intake even when he is using two other fruits of the lowest sugar content.</p>		

YISHUN TOWN SECONDARY SCHOOL

MARKING SCHEME

Exam : 2020 YTSS 4E/5N Prelim

Date : 27 August (Thur)

Subject : Sec 4E/5N Maths

Paper No. : 1

Qn	Key Steps / Solution	Marks	Remarks
1(a)	$\frac{\sqrt{2}}{2}$, π	B1	
(b)	10	A1	
2	$P\left(1 + \frac{1.25}{100}\right)^5 - P = \1000 $P\left(\left(1 + \frac{1.25}{100}\right)^5 - 1\right) = \1000 $P = \$15604.97$	M1 M1 A1	
3	$\frac{12}{13}$	M1 B1	for 12 using Pythagoras' Thm
4	$x + 100 \times 3 + (180 - 50) = 3 \times 180$ $x = 110$	M1 A1	
5	$y = \frac{k}{\sqrt{x}}$ <p>where k is a constant.</p> <p>When $y = 5$</p> $5 = \frac{k}{\sqrt{x}}$ <p>New $x = 4x$</p> $y = \frac{k}{\sqrt{4x}}$ $y = \frac{k}{2\sqrt{x}}$ $= \frac{5}{2}$ $= 2\frac{1}{2}$	M1 M1 A1	

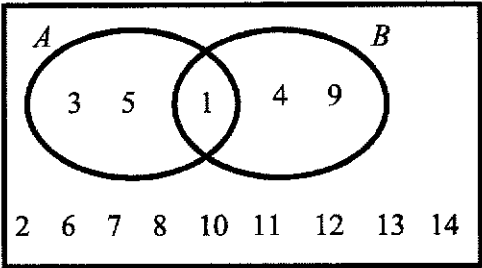
Qn	Key Steps / Solution	Marks	Remarks
6(i)	ξ 	B1 B1	for set A and B for outside
(ii)	$A \cap B' = \{3, 5\}$	A1	
(iii)	\in	A1	
7	$P : Q : R$ $= 1.25x : x : 1.75 \times 1.25x$ Percentage = $\frac{1.75 \times 1.25x}{x} \times 100\%$ $= 218.75\%$	M1 A1	
8(i)	There are people with more than 1 type of symptoms.	B1	
(ii)	No, since the total percentage does not add up to 100%.	B1	
9	$\frac{1}{3}x^2 = 3x$ $x^2 - 9x = 0$ $x(x-9) = 0$ $x = 0$ or $x = 9$	M1 A1+1	
10	$\frac{1}{3^2} \times 3^{3n} = 3^0$ $\frac{1}{2} + 3n = 0$ $3n = -\frac{1}{2}$ $n = -\frac{1}{6}$	M1 M1 A1	for converting to base 3 for equating
11(a)	$0.00014 = 1.4 \times 10^{-4}$	A1	
(b)	$0.00014 \text{ mm} = 1.4 \times 10^{-7} \text{ m}$ $= 1.4 \times 10^2 \times 10^{-9} \text{ m}$ $= 140 \text{ nm}$	M1 A1	
12	$3x - 1 < 2x + 3$ and $2x + 3 \leq 7 + 5x$ $x < 4$ $-4 \leq 3x$ $x \geq -\frac{4}{3}$ $-\frac{4}{3} \leq x < 4$	M1 A1	Either vertical or horizontal marking

Qn	Key Steps / Solution	Marks	Remarks
13	$\left(\frac{-2p^3}{q^{-1}}\right)^2 \div \left(\frac{8q^0}{p^3}\right)^{\frac{1}{3}} = \frac{4p^6}{q^{-2}} \times \frac{p}{2}$ $= 2p^7q^2$	M1 + 1 A1	for each fraction
14	The correct mean volume is 0.6 cm³ less (1.2 cm³) and the standard deviation remains unchanged .	B2	
15(a)	$1728 = 2^6 \times 3^3$	A1	
(b)	The powers of the bases are multiple of 3. Hence 1728 is a perfect cube.	B1	
(c)	$k = 3$	B1	
16 (a)	$\text{constant} = \frac{93 - 36}{3}$ $= 19$ $p = 55 \quad q = 74$	B1 + 1	
(b)	$T_n = 36 + 19(n-1)$ $= 17 + 19n$	A1	
(c)	$17 + 19n = 225$ $19n = 208$ $n = 10.94$ 208 is not a multiple of 19 / 208 is not exactly divisible by 19 / n is not a positive integer	M1 B1	
17 (a)	gradient = $\frac{3}{5}$	A1	
(b)	B is at (0, -2) $AB = \sqrt{(5-0)^2 + (1-(-2))^2} = 5.83$ units	A1 B1	
(c)	$\frac{1}{2} \times b \times 5 = 10$ $b = 4$ $k = -2 + 4 = 2$ or $k = -2 - 4 = -6$	A2	
18 (a)	$\text{Area of garden on the map} = \frac{324}{20.25} \times 81$ $= 1296 \text{ cm}^2$	M1 A1	

Qn	Key Steps / Solution	Marks	Remarks
(b)	$324 \text{ cm}^2 : 20.25 \text{ km}^2$ $18 \text{ cm} : 4.5 \text{ km}$ Actual distance between two schools = $\frac{4.5}{18} \times 54$ $= 13.5 \text{ km}$	M1 A1 M1	for taking linear scale for linear scale
(c)	$1 \text{ cm} : 0.25 \text{ km}$ $1 : 25 \text{ 000}$ $n = 25 \text{ 000}$	A1	
19 (a)	$P(\text{wins a grand prize}) = \frac{1}{6}$	A1	
(b)	$P(\text{wins a voucher}) = \frac{5}{12}$	A1	
(c)	$P(\text{wins at least a prize}) = 1 - P(\text{Miss, Miss})$ $= 1 - \frac{5}{12} \left(\frac{5}{12} \right)$ $= \frac{119}{144}$	M1 A1	
	<u>Alternative</u> $P(\text{Miss, Win}) + P(\text{Win, Miss}) + P(\text{Win, Win})$ $= \frac{7}{12} \left(\frac{5}{12} \right) + \frac{5}{12} \left(\frac{7}{12} \right) + \frac{7}{12} \left(\frac{7}{12} \right) = \frac{119}{144}$		
20 (a)	$x = 1$	A1	
(b)	$8a = 4$ $a = \frac{1}{2}$	A1	
(c)	For $k > 4.5$, the line $y = k$ does not intersect the graph.	B1	
(d)	$\frac{1}{2}(x+2)(4-x) = -\frac{1}{2}x + \frac{5}{2}$ $(x+2)(4-x) = -x+5$ $4x - x^2 + 8 - 2x = -x+5$ $x^2 - 3x - 3 = 0$	M1 A1	

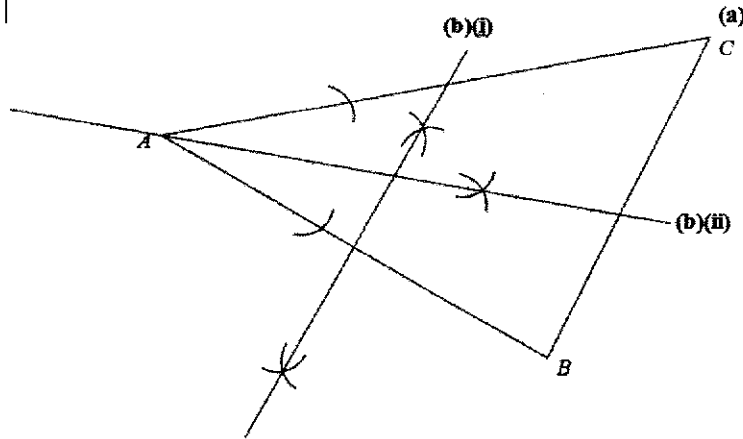
Qn	Key Steps / Solution	Marks	Remarks
21(a)(i)	<p>angle $ABC = 90^\circ$ (rt angle in semicircle)</p> <p>(ii) angle $BCE = 180^\circ - 90^\circ - 20^\circ$ (angle sum of triangle) $= 70^\circ$</p> <p>(iii) angle $BCD = 180^\circ - 70^\circ$ (adj angles on str line) $= 110^\circ$ angle $BAC = 180^\circ - 110^\circ - 46^\circ$ (angles in opp seg) $= 24^\circ$</p> <p>(b) angle $BDC = 24^\circ$ (angles in the same seg) angle $XDA = 90^\circ - 24^\circ$ (rt angle in semicircle) $= 66^\circ$ angle $XDA \neq$ angle CAD, hence $AX \neq DX$. AX and DX are not the radii of the circle. (Triangle AXD is not an isosceles triangle.) Hence X is not the centre of the circle.</p> <p>(c) angle $CBE = 90^\circ$ (rt angle in semicircle) Therefore a semicircle can be drawn passing through the points B, C, E.</p>	<p>A1</p> <p>A1</p> <p>M1</p> <p>A1</p> <p>M1</p> <p>M1</p> <p>B1</p> <p>A1</p>	<p>or $90^\circ + 20^\circ$ (ext angles)</p> <p>or angle $DXC = 60^\circ + 46^\circ = 106^\circ$ (ext angles) Since angle $DXC \neq 2 \times$ angle DAC Angle at centre $\neq 2$ angle at circumference, X is not the centre of the circle. (B1)</p>
22(a)	 <p>(b)(i) Anywhere on perpendicular bisector and top left region</p> <p>(ii)</p> <p>(c)</p>	<p>B1</p> <p>B1</p> <p>B1</p> <p>B1</p>	<p>for point C</p>

Qn	Key Steps / Solution	Marks	Remarks
23(a)	$\frac{1}{2} \times 72 \times v = 1620$ $v = \frac{1620}{36}$ $v = 45$ <p>Greatest speed = 45 m/s</p>	M1 A1	
(b)	$\frac{\text{speed}}{32} = \frac{45}{48}$ $\text{speed} = \frac{45}{48} \times 32$ $= 30 \text{ m/s}$	M1 A1	
(c)	$\text{deceleration} = \frac{45}{24} = 1.875 \text{ m/s}^2 \quad \text{or} \quad 1\frac{7}{8}$	A1	Must be exact

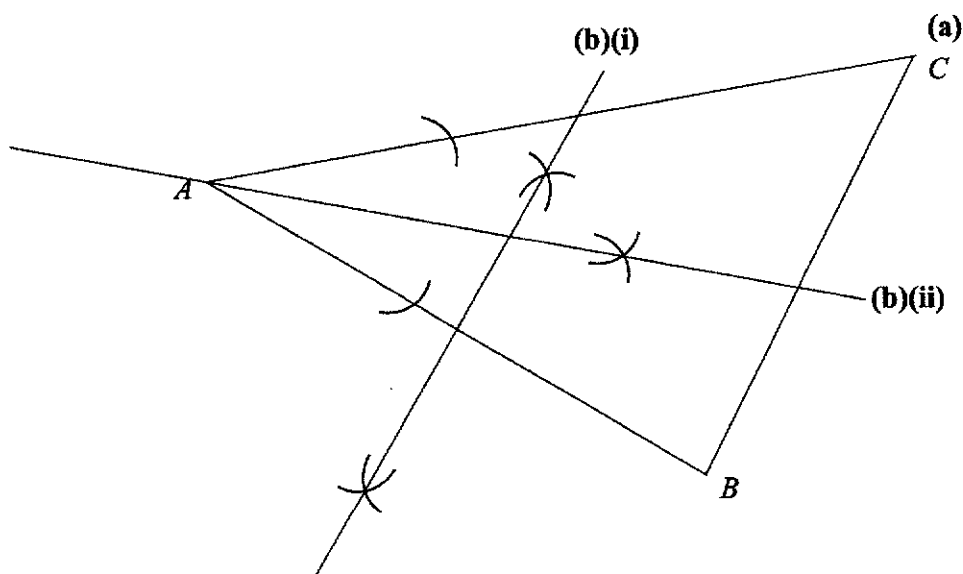

YISHUN TOWN SECONDARY SCHOOL

MARKING SCHEME

Exam : 2020 YTSS 4E/5N MYE

Date : 31 August (Monday)

Subject : Sec 4E/5N Maths

Paper No. : 2

Q ⁿ	Key Steps / Solution	Marks	Remarks
1a	$\frac{5a-3b}{2a} = \frac{4}{3}$ $15a-9b=8a$ $7a=9b$ $\frac{a}{b} = \frac{9}{7}$	M1 A1	
1bi	$(x-3)^2 - 8$	B1	
1bii	$(x-3)^2 - 8 = 0$ $(x-3)^2 = 8$ $x-3 = \pm\sqrt{8}$ $x = 5.83$ or $x = 0.17$	M1 A1A1	No mark awarded if solve using methods other than complete square
1c	Number of days needed for 4500 workers at 10 hours $= \frac{8 \times 1800}{10} = 1440$ Number of days needed for 4800 workers at 10 hours $= \frac{1440 \times 4500}{4800} = 1350$ OR Number of days needed for 4800 workers at 8 hours $= \frac{1800 \times 4500}{4800} = 1687.5$ Number of days needed for 4800 workers at 10 hours $= \frac{1687.5 \times 8}{10} = 1350$	M1 A1 M1 A1	
2a	$m^2 - 2mn + n^2 - p^2 = (m-n)^2 - p^2$ $= (m-n-p)(m-n+p)$	M1 A1	
2b	$\frac{7}{2x-3} + \frac{x+1}{6-4x} = \frac{7}{2x-3} + \frac{x+1}{2(3-2x)}$ $= \frac{14}{2(2x-3)} - \frac{x+1}{2(2x-3)}$ $= \frac{13-x}{2(2x-3)}$	M1 M1 A1	change of sign for common denominator

2ci	$p^2 = 1 + \frac{p^2}{1.125}$ $p^2 - \frac{p^2}{1.125} = 1$ $\frac{1}{9}p^2 = 1$ $p^2 = 9$ $p = 3 \text{ or } -3$	M1 A1	 Both 3, -3
2cii	$p = \sqrt{1 + \frac{p^2}{r}}$ $p^2 = 1 + \frac{p^2}{r}$ $p^2 r - r = p^2$ $r(p^2 - 1) = p^2$ $r = \frac{p^2}{p^2 - 1}$ <p>OR</p> $p^2 - 1 = \frac{p^2}{r}$ $\frac{r}{p^2} = \frac{1}{p^2 - 1}$ $r = \frac{p^2}{p^2 - 1}$	M1 M1 A1 M1 M1 A1	Removing Square root Factorise r Removing Square root Make reciprocal
3a	$\frac{5940}{x}$	B1	
3b	$\$ \left(\frac{5940}{x} + 600 \right) (x + 0.5)$	B1	
	$\left(\frac{5940}{x} + 600 \right) (x + 0.5) = 5940 + 3870$ $5940 + \frac{2970}{x} + 600x + 300 = 9810$ $\frac{2970}{x} + 600x - 3570 = 0$ $600x^2 - 3570x + 2970 = 0$ $20x^2 - 119x + 99 = 0$	M1 M1 A1	Form equation Expansion Correct steps to final answer
3c	$x = \frac{-(-119) \pm \sqrt{(-119)^2 - 4(20)(99)}}{40}$ $x = 4.95 \quad x = 1$	M1 A1A1	Also accept use of complete square as method
3d	$= \frac{5940}{4.95} + 600 = 1800$	B1	

4ai	$\begin{pmatrix} 3.5 \\ 3 \\ 1.5 \end{pmatrix}$ or $\begin{pmatrix} 3.5 \\ 3.0 \\ 1.5 \end{pmatrix}$ or $\begin{pmatrix} 3.50 \\ 3.00 \\ 1.50 \end{pmatrix}$	B1	
4aii	$\begin{pmatrix} 100 & 80 & 150 \\ 60 & 75 & 120 \end{pmatrix} \begin{pmatrix} 3.5 \\ 3 \\ 1.5 \end{pmatrix} = \begin{pmatrix} 815 \\ 615 \end{pmatrix}$	B1	
4aiii	815 represents the total cost price of hand sanitizers, hand soap and wipes for Pharmacy A. 615 represents the total cost price of hand sanitizers, hand soap and wipes for Pharmacy B. OR The elements represents total cost price of hand sanitizers, hand soap and wipes for each pharmacy respectively.	B1	
4aiv	$\frac{1}{100}(20 \ 25) \begin{pmatrix} 815 \\ 615 \end{pmatrix} = (163 + 153.75) = (316.75)$	B1	
4av	The matrix represents the total amount of profit made by both pharmacies.	B1	
4bi	Percentage discount = $\frac{2675 - 2140}{2675} \times 100\%$ = 20%	M1 A1	
4bii	Price before GST = $\frac{\$2140}{107} \times 100$ = \$2000	M1 A1	
4biii	Deposit = $0.1 \times \$2140 = \214 Amount paid by hire purchase less deposit = $2500 - \$214$ = 2286 Monthly payment = $2286 \div 36$ = \$63.50	M1 M1 A1	Deposit Amt less deposit
5a	0	B1	
5b	Refer to graph	P2 C1	All points marked as shown in table. P1 if 1 point to 2 points not marked or error in marking. Zero if > 2 errors. Smooth Curve passing through all points
5c	Maximum: 41 (Must be read from student's graph) Minimum: -6 (Must be read from student's graph)	B1 B1	Accept 40 to 41.5 Reject answers < 40 Accept -5 to -6.5 Reject answers > -5
5d	$\frac{39 - (5)}{1 - 0} = 34.0$	B1 B1	Tangent line Accept 31 to 38.2

5ei	Refer to graph	B1	Straight line $y = 30 - 5x$ drawn from $x = 0$ to $x = 6$
5eii	$x = 1.2, x = 3$	B1	1.2 Accept (1.1 to 1.3)
		B1	$x = 3$

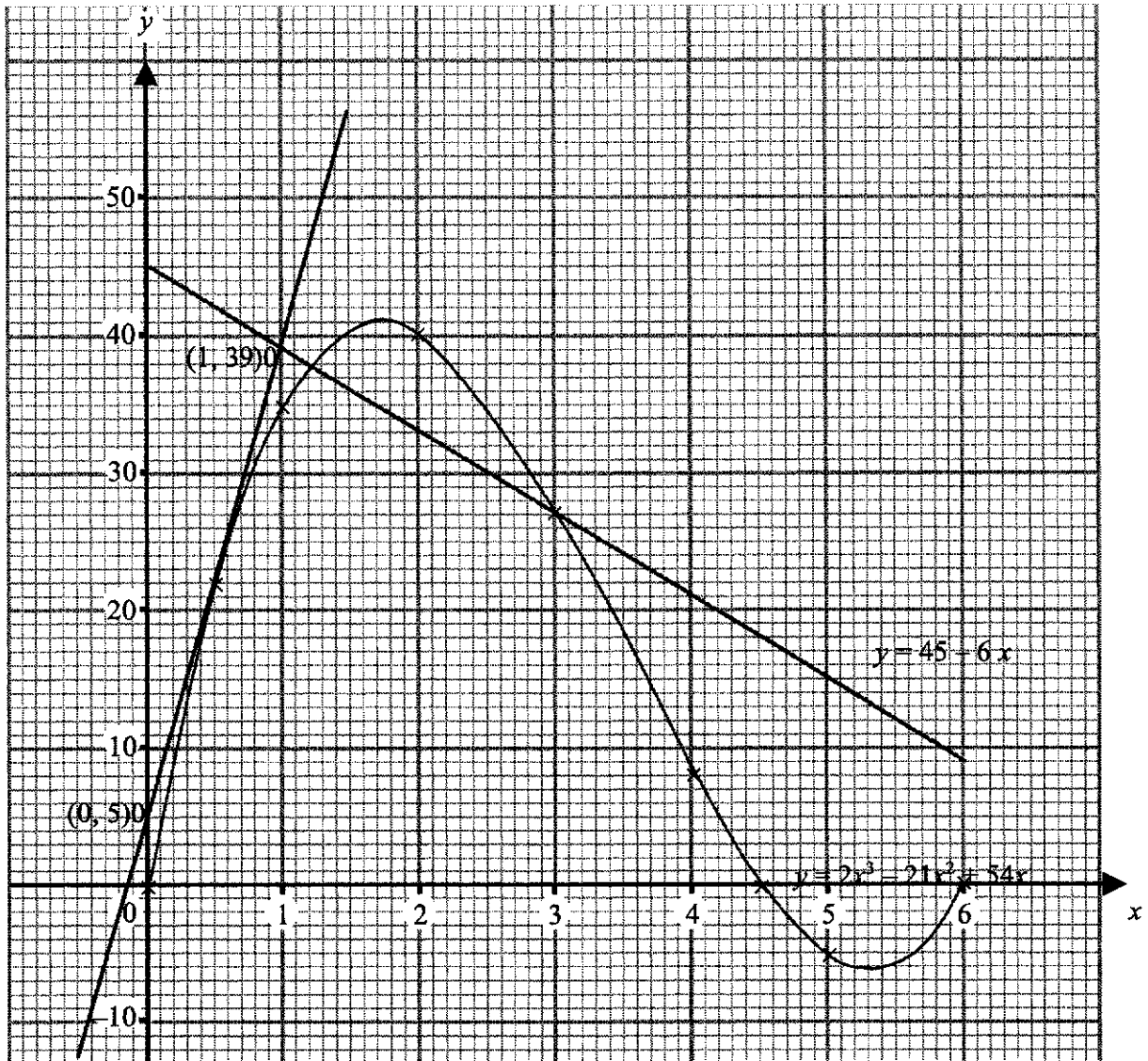

6a	$\angle ABE = \angle FDE$ (alt. \angle s, // lines) $\angle BAE = \angle DFE$ (alt. \angle s, // lines) $\angle BEA = \angle DEF$ (vert. opp. \angle s) Hence by Angle-Angle Similarity Test, triangle ABE and triangle FDE are similar.	[M1] [A1]	For any 1 set of correct angles with correct reason For any 2nd set of correct angles with correct reasons and conclusion
6b	$\frac{AE}{EF} = \frac{2}{3}$ $\frac{DF}{AB} = \frac{3}{2}$ $DF = \frac{3}{2} \times 8 = 12$ $CD = 12 + 8 = 20$	M1 A1	For $\frac{3}{2} \times 8$
6c	$\frac{\text{Area of triangle } ABE}{\text{Area of triangle } FDE} = \left(\frac{2}{3}\right)^2$ $\text{Area of triangle } ABE = \frac{4}{9} \times 54 = 24$	M1 A1	
6d	$\frac{\text{area of triangle } ADE}{\text{area of triangle } ABE}$ $= \frac{\frac{1}{2}(\perp \text{ from } A \text{ to } DE)DE}{\frac{1}{2}(\perp \text{ from } A \text{ to } BE)BE}$ $= \frac{DE}{BE} = \frac{FE}{AE}$ (Since $\triangle ABE$ and $\triangle FDE$ are similar) $= \frac{3}{2}$	B1	
6e	$\text{Area } \triangle ADE : \text{Area } \triangle ABE : \text{Area } \triangle FDE$ $3 : 2$ $4 : 9$ $6 : 4 : 9$ $\frac{\text{area of triangle } ABE}{\text{area of triangle } ADF} = \frac{4}{9+6} = \frac{4}{15}$	M1 A1	
7a	$\frac{1}{2}(15)^2 (\text{reflex } \angle POQ) = 450$ $\text{reflex } \angle POQ = \frac{450 \times 2}{15^2} = 4$	M1 A1	
7b	$= (15)(4) + 15 + 15$ $= 90$	M1 A1	

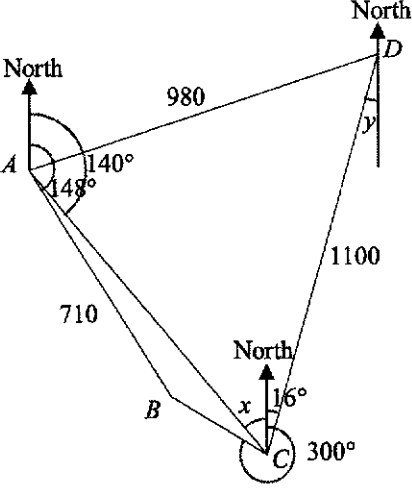
7ci	Base circumference = $15(4) = 60$ cm Radius = $\frac{60}{2\pi}$ cm Height = $\sqrt{15^2 - \left(\frac{60}{2\pi}\right)^2} = 11.56766 = 11.6$	M1 M1 A1	Circumference Radius
7cii	$= \frac{1}{3} \pi \left(\frac{60}{2\pi}\right)^2 (11.56766)$ $= 1104.630 = 1100 \text{ (3 sig. fig.)}$	M1 A1	
8a	 <p> $x = 180^\circ - 140^\circ = 40^\circ$ $\angle ACB = 360^\circ - 300^\circ - 40^\circ = 20^\circ$ </p>	M1 A1	40° seen or implied in diagram or working
8b	$\angle BAC = 148^\circ - 140^\circ = 8^\circ$ $\angle ABC = 180^\circ - 8^\circ - 20^\circ = 152^\circ$ $\frac{AC}{\sin 152^\circ} = \frac{710}{\sin 20^\circ}$ $AC = \frac{710 \sin 152^\circ}{\sin 20^\circ} = 974.57654 = 975 \text{ (3 s.f.)}$	M1 M1 A1	152° seen or implied in diagram or working Use of Sine Rule
8c	$y = 16^\circ$ $\cos \angle ADC = \frac{980^2 + 1100^2 - (974.57654)^2}{2(980)(1100)}$ $\angle ADC = 55.5184^\circ$ $\text{Bearing of } A \text{ from } D = 180^\circ + 16^\circ + 55.5184^\circ$ $= 251.5184 = 251.5^\circ \text{ (1 d.p.)}$	M1 M1 A1	or $\frac{\sin \angle ADC}{974.57654} = \frac{\sin(16^\circ + 40^\circ)}{980}$ 180° + 16° + their $\angle ADC$
8d	Shortest distance from B = $710 \sin 8^\circ$ $= 98.8 \text{ (3 s.f.)}$	M1 A1	

8e	Horizontal distance = $\frac{900}{\tan 18^\circ}$ = 2769.91518 m = 2.77 km (3 s.f.)	M1 A1	
9a	35.4 °C + 1.8 °C = 37.2 °C x = 2	B1	
9bi	a = 35.4 b = 35.9 c = 36.45 d = 36.7	B1 B1 B1 B1	
9bii	36.7 – 35.9 = 0.8	B1	
9ci	Mean temperature = 36.3555 °C = 36.4 °C	B1	
9cii	Standard deviation = 0.537 °C	B1	
9d	1. The temperatures of the girls are higher than the boys as the mean temperature of the girls is greater than the mean temperature of the boys. 2. The temperatures of the girls are less consistent compared to the boys, since the standard deviation of temperatures is higher. OR The temperatures of the boys are less varied/are less widely spread as compared to the temperatures of the girls.	B1 B1	
10a	Amount of ice used in one cup = $2 \times 2 \times 1.5 \times 6$ = 36 cm ³	B1	
10b	Amount of juice used with ice = 300 – 36 = 264 ml Amount of sugar 1 cup of apple juice = $\frac{19}{75} \times 264 = 66.88$ g	M1 A1	

<p>10c</p>	<p><u>Amount of sugar per ml of</u></p> <p>Apple: 0.25333g Orange: 0.18667g Pear: 0.18889g Pineapple: 0.14127g Watermelon: 0.14815g</p> <p>Amount of fruit juice used for each fruits $= \frac{264}{3} = 88 \text{ ml}$</p> <p>Fruits to use: Pineapple, Watermelon and Apple</p> <p>Amount of sugar in the mixed fruit juice $= 88 \times (0.14815 + 0.14127 + 0.25333)$ $= 47.762\text{g}$</p> <p>Number of teaspoons $= 47.762 \div 5 = 9.5524$</p> <p>As a person may take in sugar in other meals and his mixed fruit juice almost took up 1 day's intake hence his new recipe will NOT be suitable for Singaporeans who wish to stay healthy and avoid diabetes.</p>	<p>U: Per Unit quantity 2m for per unit qty of 5 fruits 1m for per unit qty of 1 fruit only (but < 5 fruits)</p> <p>E1 E: Determine the Equal portion of fruits used</p> <p>F1 F: Determine the Fruits used (Given if observed 0.14815, 0.14127 and 0.25333 used)</p> <p>S1 S: Determine the total amount of sugar in grams</p> <p>T1 T: Determine amount of teaspoon or amount of sugar for 10 teaspoon.</p> <p>A1 A: Answer with appropriate reason</p>
-------------------	--	--

