

NAME:	CLASS:	INDEX NO:
-------	--------	-----------



QUEENSWAY SECONDARY SCHOOL
PRELIMINARY EXAMINATION 2018
SECONDARY 4 EXPRESS

Parent's Signature:

PHYSICS

Paper 1 Multiple Choice

6091/01

12 Sep 2018

1 hour

Additional Materials: Multiple Choice Answer Sheet

READ THESE INSTRUCTIONS FIRST

Write in soft pencil.

Do not use staples, paper clips, glue or correction fluid.

Write your name and index number on the Answer Sheet in the spaces provided.

There are **forty** questions on this paper. Answer **all** questions. For each question, there are four possible answers, **A, B, C** and **D**.

Choose the **one** you consider correct and record your choice in **soft pencil** on the separate Answer Sheet.

Read the instructions on the Answer Sheet very carefully.

Each correct answer will score one mark. A mark will not be deducted for a wrong answer. Any rough working should be done in this booklet.

The use of an approved scientific calculator is expected, where appropriate.

This document consists of **18** printed pages.

Setters: Mrs Pang FH, Ms Tan YN

[Turn over

1 Which unit is equivalent to the unit for power?

- A kg m s^{-1}
- B $\text{kg m}^2 \text{s}^{-1}$
- C $\text{kg m}^2 \text{s}^{-2}$
- D $\text{kg m}^2 \text{s}^{-3}$

2 Forces of 3.0 N and 8.0 N act at a point.

Which one of the following could **not** be the magnitude of their resultant?

- A 4.0 N
- B 6.0 N
- C 9.0 N
- D 11 N

3 The graph below shows how the velocity of a mass changes with time.

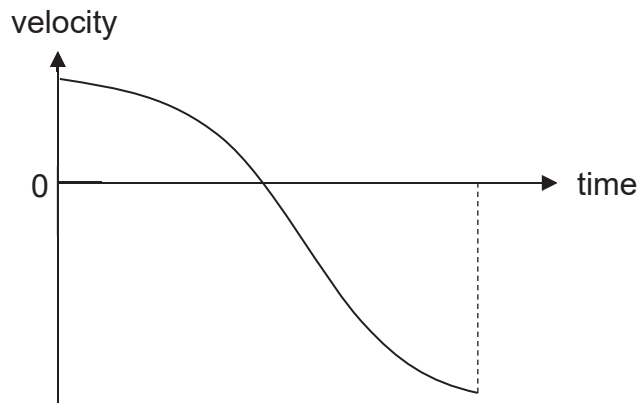

Which of the following statements about the motion of the mass is **not** true?

- A The speed of the mass decreases at an increasing rate and then increases at a decreasing rate.
- B The acceleration of the mass is negative throughout its motion.
- C The final speed of the mass is larger than its initial speed.
- D The total displacement of the mass is positive.

- 4 A car is decelerating uniformly and its velocity changes from 20 m s^{-1} to 15 m s^{-1} in 4.0 s .
What further distance will it need to travel before it stops completely?

- A 13 m
B 90 m
C 160 m
D 210 m

- 5 A ball is thrown across a flat ground.



Which statement describes the motion of the ball, when the effects of air resistance are negligible?

- A The ball lands with the same speed at which it is thrown.
B The speed of the ball is zero at the highest point of the motion.
C The acceleration of the ball is zero at the highest point of the motion.
D The acceleration of the ball is largest at the start and decreases slowly to zero.
- 6 A crate of mass 7.0 kg rests on a rough horizontal surface. A light string attached to the crate passes over a smooth pulley and supports a load of mass 2.5 kg at its other end.

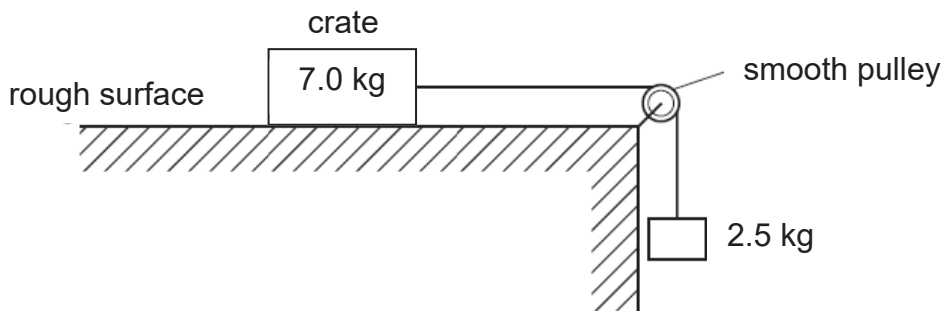

When the crate is released, a frictional force of 5.0 N acts on it. The gravitational field strength is 10 N kg^{-1} .

What is the acceleration of the crate?

- A 2.1 m s^{-2}
B 3.1 m s^{-2}
C 4.5 m s^{-2}
D 10 m s^{-2}

7 A ladder rests on a rough ground and leans against a rough wall.

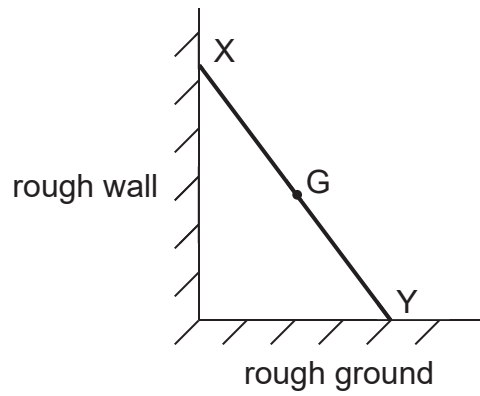

Its weight W acts through the centre of gravity G . Forces also act on the ladder at X and Y . These forces are X and Y respectively.

Which vector triangle represents the forces on the ladder?

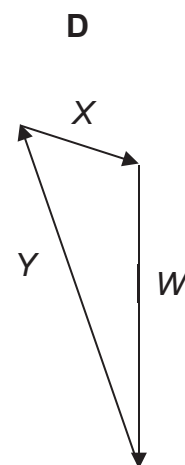
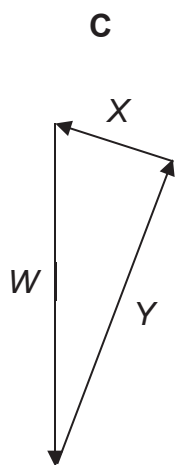
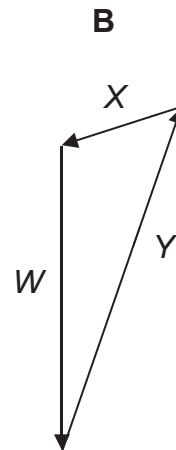
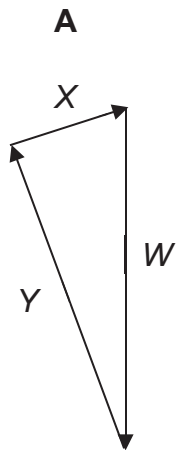

- 8 Three balls have densities of 0.9 g/cm^3 , 1.1 g/cm^3 and 1.3 g/cm^3 respectively. In turn, they are put into four beakers containing different liquids.

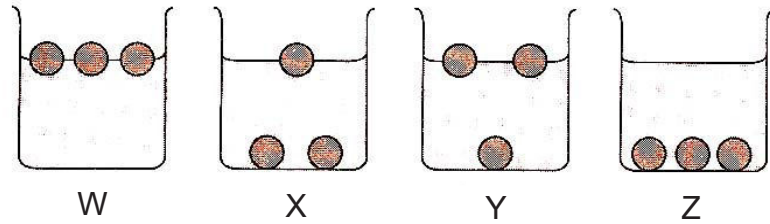

Three of the beakers hold oil of density 0.8 g/cm^3 , water of density 1.0 g/cm^3 and mercury of density 13.6 g/cm^3 . These are

- A W, X and Z respectively.
 B X, Z and Y respectively.
 C Y, Z and X respectively.
 D Z, X and W respectively.
- 9 An L-shaped rigid lever arm is pivoted at point P. Three forces act on the lever arm, as shown in the diagram.

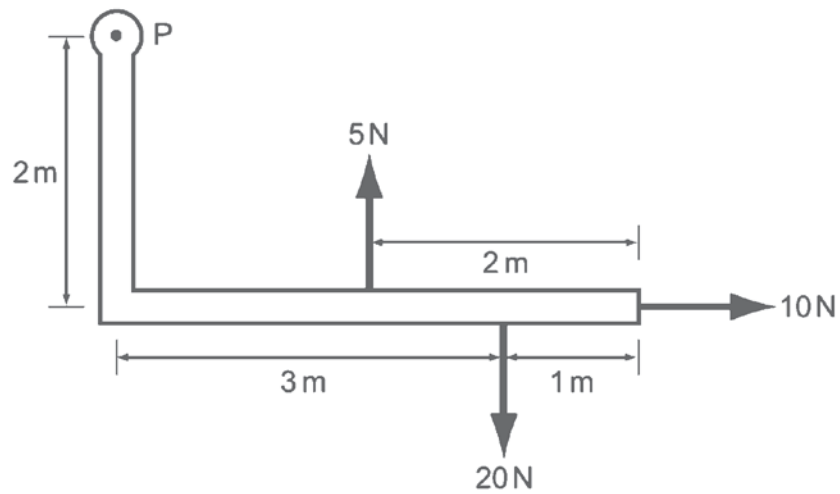

What is the magnitude of the resultant moment of these forces about point P?

- A 30 N m
 B 35 N m
 C 50 N m
 D 90 N m

- 10 The stability of a bus is tested by tilting it on a ramp. The diagram shows a bus that is just about to topple over.

Where is the centre of gravity of the bus?

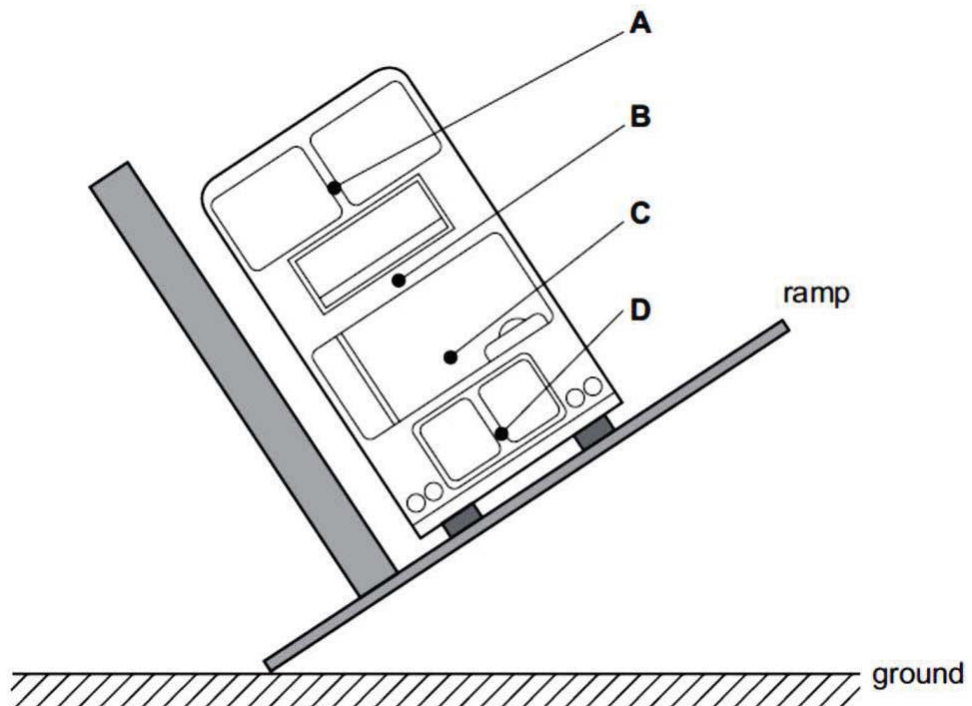

- 11 The diagram shows a U-tube containing oil and water.

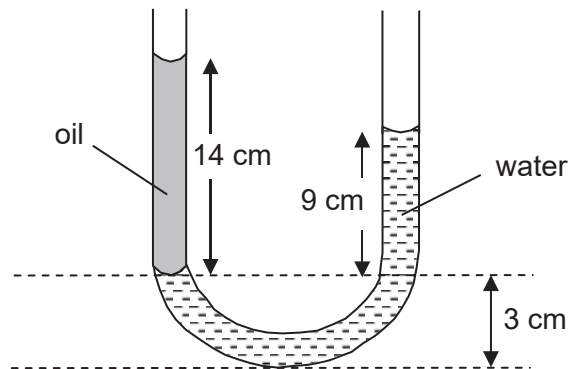

What is the ratio of the density of oil to the density of water?

- A 9 : 14
- B 14 : 9
- C 12 : 17
- D 17 : 12

- 12 An object of mass m slides up a frictionless slope from point X with an initial velocity v , as shown in the figure below. The object comes to a stop at a height h above X.

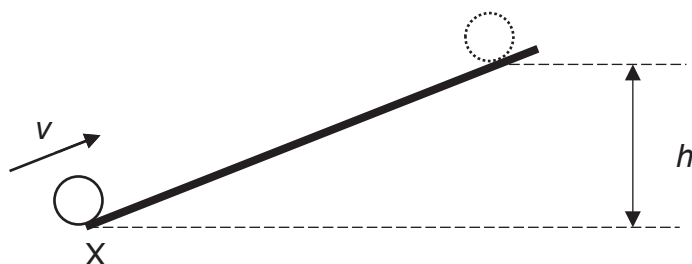

A second object of mass $3m$ now slides up the same slope from X with a velocity of $\frac{v}{3}$.
What is the height it will rise to?

- A $\frac{h}{9}$
 B $\frac{h}{3}$
 C $\frac{h}{\sqrt{3}}$
 D h
- 13 A student observes the Brownian motion of smoke particles in air with a microscope. She sees moving points of light.
Where do these points of light come from?
- A The vibrating air particles only.
 B The vibrating smoke particles only.
 C The continuously moving air particles only.
 D The continuously moving smoke particles only.
- 14 A vessel contains a gas. Some gas is pumped out of the vessel.
If the volume of the vessel is kept constant, which statement is **not** correct?
- A The pressure of the gas decreases.
 B The total weight of the vessel decreases.
 C The average intermolecular distance decreases.
 D The average kinetic energy of the molecules decreases.

- 15 By what processes does a beaker of hot water lose energy?
- A Convection and radiation only.
 B Evaporation and radiation only.
 C Conduction, convection and radiation only.
 D Conduction, convection, evaporation and radiation.
- 16 Which of the following processes is an illustration of heat transfer by radiation only?
- A From the sun to the earth atmosphere.
 B From the hot fire place to the rest of the room.
 C From a hot flame to the hands placed above the hot flame.
 D From the filament of a lamp to the hands placed beside the lamp.
- 17 Which of the following is **not** one of the steps needed in the determination of the ice point when calibrating a liquid-in-glass thermometer with the Celsius scale?
- (i) Immerse the bulb and the lower part of the thermometer stem into a funnel containing pure melting ice.
 (ii) Measure the temperature of the first few drops of melted ice which should be $0\text{ }^{\circ}\text{C}$.
 (iii) When the mercury level in the thermometer stem remains steady, mark that level as ice point on the stem.
- A (i) only
 B (ii) only
 C (i) and (ii)
 D (i) and (iii)
- 18 Three liquids with their respective boiling and freezing points are shown in the table below.

	mercury	alcohol	pentane
freezing point	$-39\text{ }^{\circ}\text{C}$	$-112\text{ }^{\circ}\text{C}$	$-180\text{ }^{\circ}\text{C}$
boiling point	$357\text{ }^{\circ}\text{C}$	$78\text{ }^{\circ}\text{C}$	$36.5\text{ }^{\circ}\text{C}$

Which liquid(s) could be filled in a thermometer that can measure between $-110\text{ }^{\circ}\text{C}$ and $32\text{ }^{\circ}\text{C}$?

- A alcohol
 B pentane
 C mercury
 D alcohol or pentane

- 19 4 g of hot water at $100\text{ }^{\circ}\text{C}$ is added to some ice at $0\text{ }^{\circ}\text{C}$. The specific latent heat of fusion of ice is 336 J/g and the specific heat capacity of water is $4.2\text{ J/(g }^{\circ}\text{C)}$.

What is the minimum mass of ice that was melted?

- A 5 g
- B 4 g
- C 3.2 g
- D 2.2 g

- 20 A transverse wave travels along a string with a constant speed. The diagram below shows the shape of the string at a certain instant.

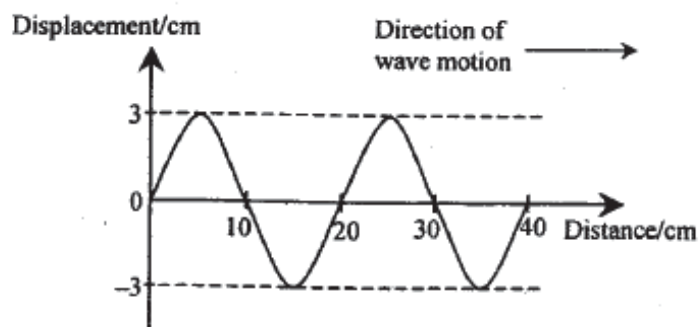

Which of the following diagrams shows the shape of the string at a quarter of a period later?

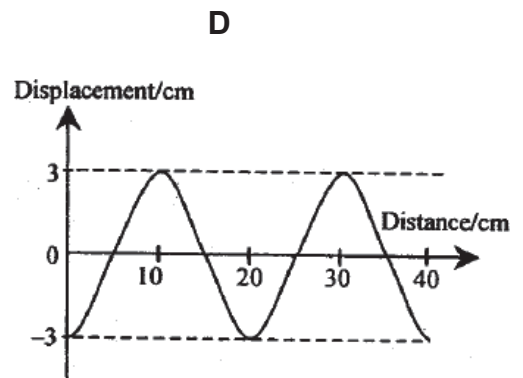
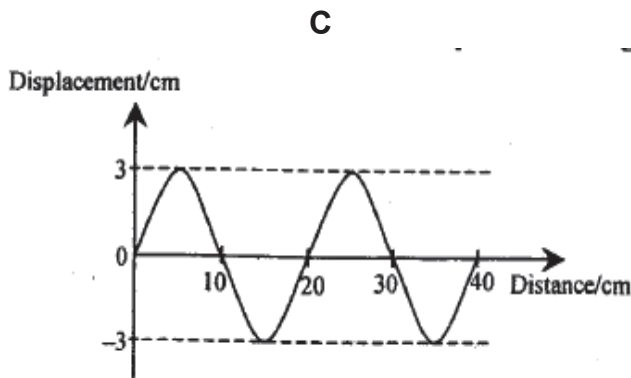
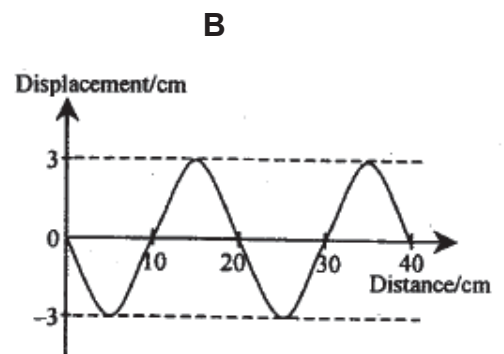
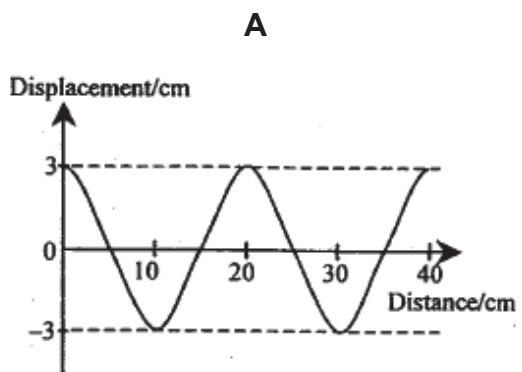

- 21 A dipper moving up and down makes waves in a ripple tank.

What will happen when the dipper frequency is decreased?

- A The waves will be further apart.
- B The waves will move more slowly across the tank.
- C The waves will move more quickly across the tank.
- D The wave peaks will be lower and the troughs higher.

- 22 Water waves travel across a ripple tank. The horizontal distance between a crest and the neighbouring trough is 25 mm, and the vertical distance between a crest and a trough is 5.0 mm. A crest travels 8.0 cm in 0.50 s.

Which one of the following is correct?

	frequency of water wave / Hz	amplitude of water wave / mm
A	3.2	2.5
B	3.2	5.0
C	6.4	2.5
D	6.4	5.0

- 23 A ray of light is incident at an angle of 20° to a mirror XY. Another mirror YZ is arranged at an angle of 60° to XY.

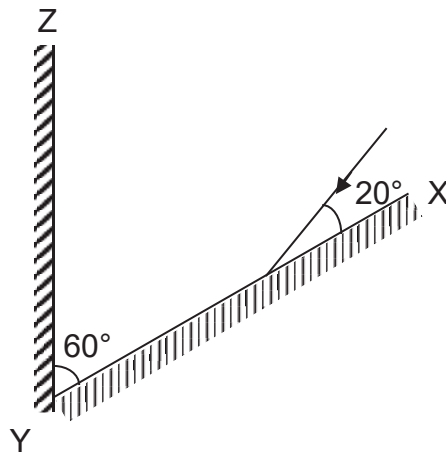

After reflection from XY, the ray is incident on YZ.

What is the angle of incidence of the ray at the mirror YZ?

- A 10°
- B 20°
- C 50°
- D 70°

- 24 Fig. (a) shows a light beam entering into a semi-circular glass block at an angle b and being refracted at an angle a . The angle b and its corresponding angle a is shown in Fig. (b).

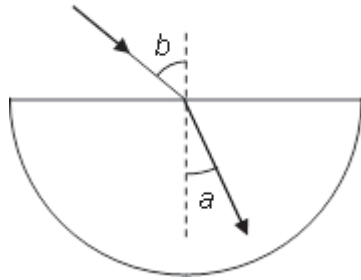

Fig. (a)

$b / ^\circ$	$a / ^\circ$
30	20
70	40

Fig. (b)

What is the critical angle of the glass block?

- A 90°
 B 50°
 C 43°
 D 40°
- 25 Below are four statements about the uses of electromagnetic radiation.
- X-rays are used in radar monitoring of speed of motor vehicles.
 - Microwaves are used in satellite communication.
 - Gamma rays are used in medical treatment.
 - Radio waves are used in intruder alarms.

How many of these statements are correct?

- A 1
 B 2
 C 3
 D 4
- 26 A sonic “tape measure” is used to measure the length of a room. It measures a time interval of 0.06 s between transmitting a sound pulse and receiving the echo. The speed of sound in air is 330 m/s.

How far is the reflecting wall from the “tape measure”?

- A 5.5 m
 B 9.9 m
 C 11.0 m
 D 19.8 m

- 27 The table shows how the speed of sound varies with substances of different densities.

substance	speed of sound in substance / m s^{-1}	density of substance / kg m^{-3}
air (gas)	330	1.29
oxygen (gas)	320	1.43
aluminium (metal)	5100	2710
iron (metal)	5000	7870
lead (metal)	1200	11300

What conclusions about the speed of sound can be drawn from this information?

- A** The speed is greater in metals than in gases.
B The speed is greatest in the most dense metal.
C The speed is greater in less dense substances.
D The speed increases as the density of the substance increases.
- 28 A light uncharged conducting ball is moved towards the positive plate.

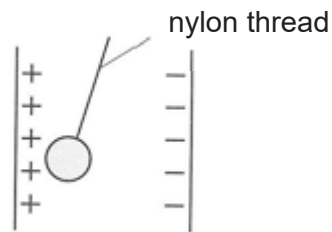

Which diagram correctly shows the charges on the ball just after it has touched the positive plates?

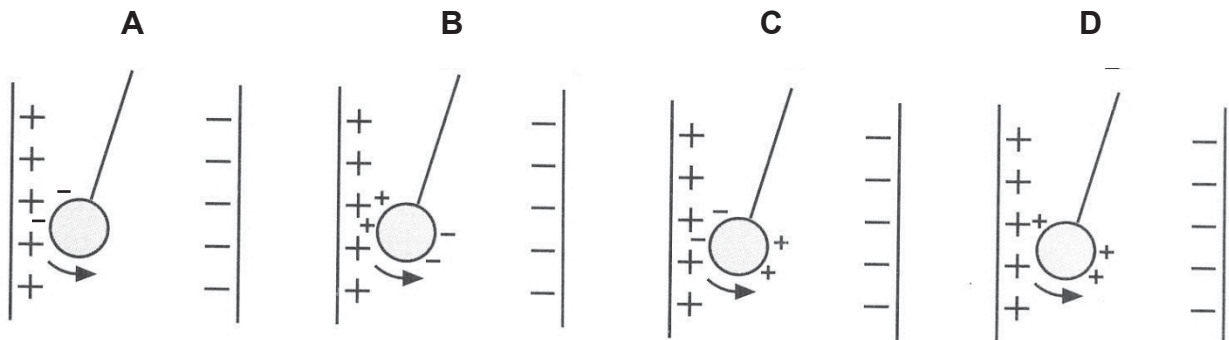

29 Some observations were made when four charged rods P, Q, R and S are placed near to each other one at a time.

- P repels Q
- P attracts R
- S attracts R

If S is negatively charged, what are the charges on P, Q and R?

	P	Q	R
A	–	–	+
B	–	+	–
C	+	–	+
D	+	+	–

30 The potential difference across a light bulb is 20 V. During a time of 15 s, the amount of electrical energy converted to other forms of energy is 12 J.

What is the current flowing in the light bulb during this time?

- A 0.040 A
- B 0.11 A
- C 9.0 A
- D 25 A

31 What is the definition of the electromotive force (e.m.f.) of a power supply?

- A the potential difference across its terminals when no current is flowing
- B the energy converted from other forms to electrical per unit charge which passes through it
- C the energy converted from electrical to other forms per unit charge which passes through it
- D the potential difference across its terminals if unit potential difference is needed to move unit charge through it

- 32 Some electric light bulb filaments are made of carbon. It is known that the resistance of carbon filaments decreases as their temperature increases.

Which graph shows how the current I through such a bulb varies with the potential difference V across it?

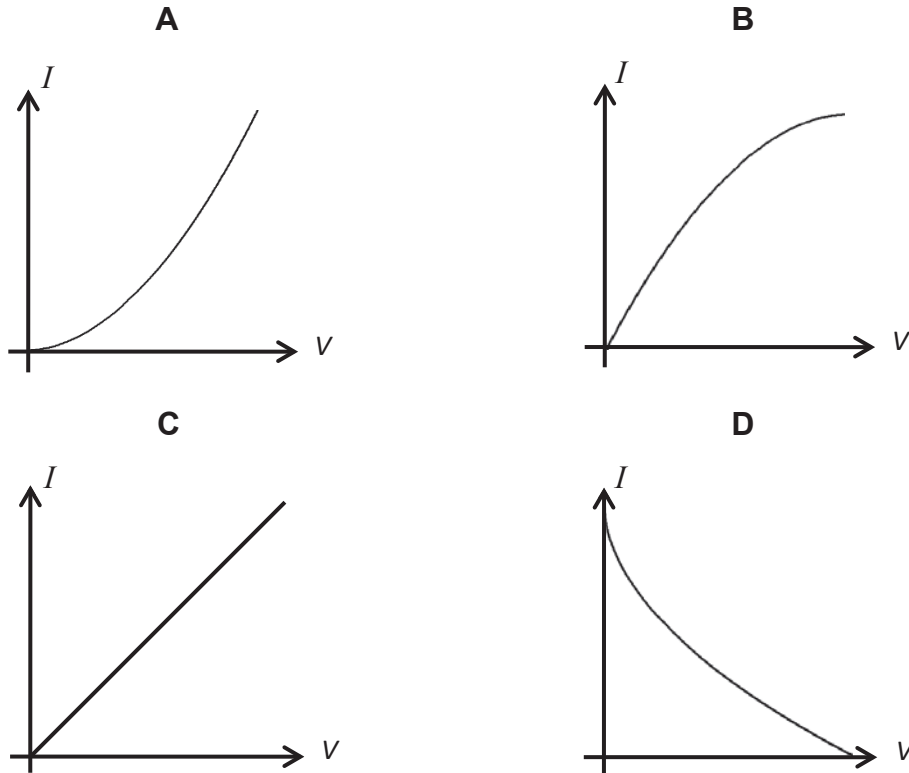

- 33 The diagram shows a network of identical resistors R_1 , R_2 , R_3 and R_4 connected to a cell. When switch S is closed, the power dissipated in each resistor is P .

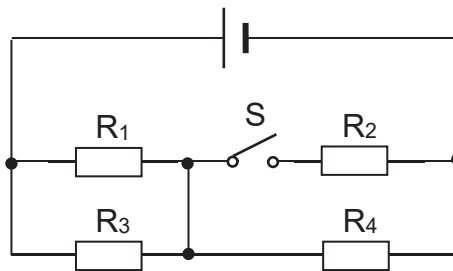

When switch S is opened, what are the powers dissipated in resistors R_3 and R_4 ?

	power dissipated in R_3	power dissipated in R_4
A	lower than P	remains as P
B	lower than P	lower than P
C	remains as P	greater than P
D	lower than P	greater than P

- 34 A battery of e.m.f. E is connected to a light dependent resistor (LDR) and two resistors, each of resistance R , as shown.

The resistance of the LDR when it is exposed to bright light is R . The currents in the two resistors are I_1 and I_2 respectively.

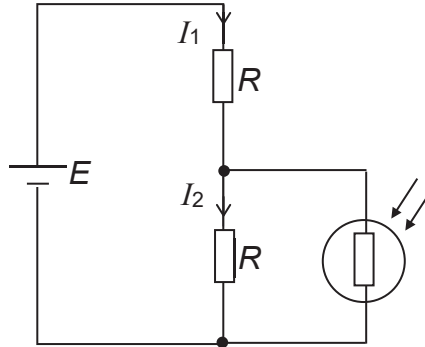

How do the currents change when the light intensity on the LDR is reduced to zero ?

	I_1	I_2
A	decrease	decrease
B	increase	decrease
C	decrease	increase
D	increase	increase

- 35 A fuse is connected to the neutral wire of a fan.

Which of the following statement(s) is/are correct?

- I The fan will not operate if the fuse blow.
- II The fan will be safe to touch when the fuse blow.
- III The fan will still be connected to the high voltage source when the fuse blow.

- A** I and II only
- B** I and III only
- C** II and III only
- D** I, II and III

- 36 A bar magnet is to be placed in a non-uniform magnetic field as shown in the figure below.

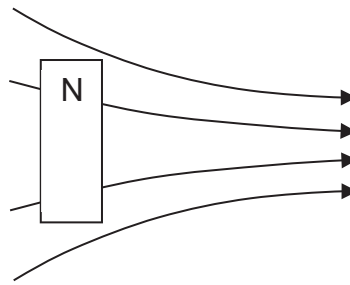

Which of the following describes the subsequent motion of the magnet?

	rotation	movement
A	anti-clockwise	to the left
B	anti-clockwise	to the right
C	clockwise	to the left
D	clockwise	to the right

- 37 A straight conductor rests in the space between two arms of a soft iron core.

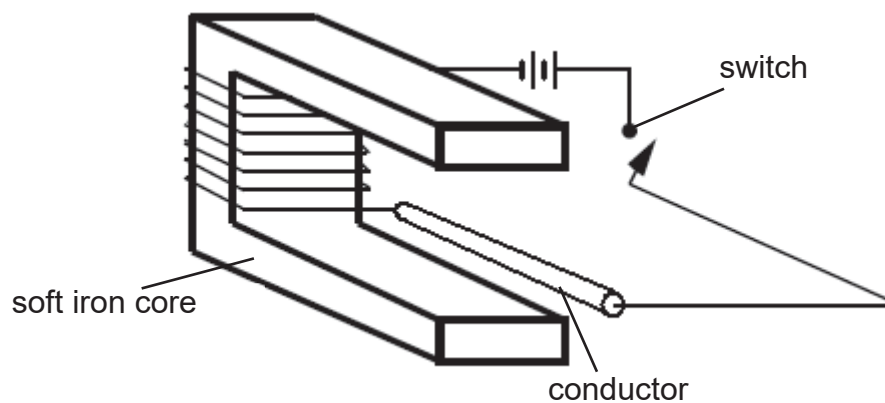

After the switch has been closed for a while, in which direction is the magnetic force acting on the conductor?

- A up
- B down
- C left
- D right

- 38 Four parallel conductors A, B, C and D, carrying equal currents, pass vertically through the four corners of a square. In conductors A and D, the current is flowing into the page, and in conductors B and C, current is flowing out of the page.

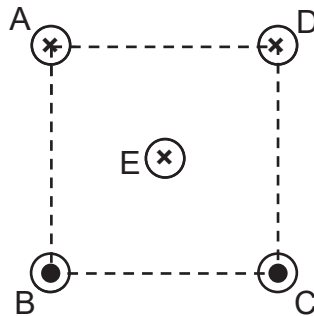

Which of the following **incorrectly** describes the resultant force on conductor E, with current flowing into the page, at the centre of the square?

- A The resultant force due to wires A and D points towards line AD, perpendicular to AD.
- B The resultant force due to wires B and C points towards line AD, perpendicular to AD.
- C The resultant force due to wires B and D points towards line AD, perpendicular to AD.
- D The resultant force due to wires A, B, C and D points towards line AD, perpendicular to AD.
- 39 The diagram shows an experimental setup showing electromagnetic induction.

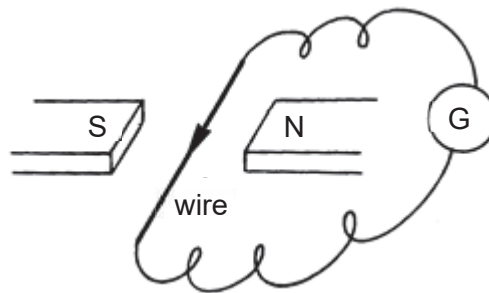

In which direction must the wire be moved to induce a current flow in the direction as shown in the diagram?

- A vertically upward
- B vertically downward
- C horizontally towards the north pole
- D horizontally towards the south pole

- 40 A transformer consists of one coil with 1200 turns and a second coil, with total of 120 turns, which can be tapped at various places.

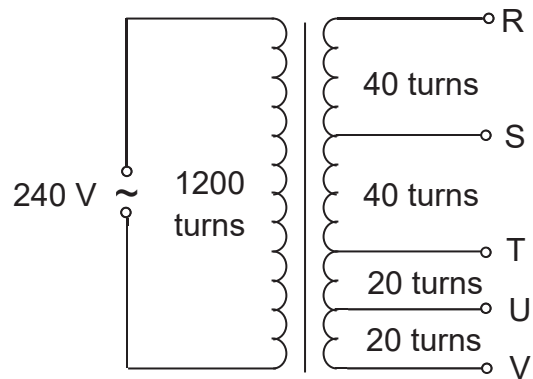

Which pair of terminals should be connected to a 12 V, 24 W lamp for it to be lit normally?

- A RU
- B SU
- C RV
- D TV

END OF PAPER

NAME:	CLASS:	INDEX NO:
-------	--------	-----------



QUEENSWAY SECONDARY SCHOOL
 PRELIMINARY EXAMINATION 2018
 SECONDARY 4 EXPRESS

Parent's Signature:

PHYSICS

Paper 2 Theory

6091/02

11 Sep 2018

1 hour 45 minutes

No Additional Materials are required.

READ THESE INSTRUCTIONS FIRST

Write your name and index number on all the work you hand in.
 Write in dark blue or black pen.
 You may use an HB pencil for any diagrams or graphs.
 Do not use staples, paper clips, glue or correction fluid.

Section A:

Answer **all** questions.

Section B:

Answer **all** questions. Question 11 has a choice of parts to answer.

Candidates are reminded that **all** quantitative answers should include appropriate units.
 The use of an approved scientific calculator is expected, where appropriate.
 Candidates are advised to show all their working in a clearly and orderly manner, as more marks are awarded for sound use of Physics than for correct answers.
 The number of marks is given in brackets [] at the end of each question or part question.

For Examiner's Use	
Section A	/50
Q9	/10
Q10	/10
E / O Q11	/10
TOTAL	/80

This document consists of **24** printed pages.

Setters: Mrs Pang FH, Ms Tan YN

[Turn over

SECTION A

Answer **all** the questions in this section in the spaces provided.
The total mark for this section is 50.

- A1** Fig. 1.1 shows an oil-drum as it floats in equilibrium in seawater.

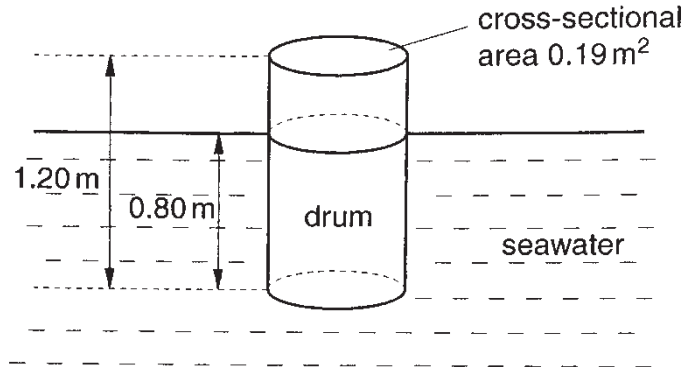

Fig. 1.1

The drum is 1.20 m long and has a cross-sectional area of 0.19 m². The length of the drum submerged under water is 0.80 m. The atmospheric pressure above the surface of the water is 1.0×10^5 Pa. The density of seawater is 1.1×10^3 kg m⁻³ and the gravitational field strength is 10 N kg⁻¹.

- (a) (i) On Fig. 1.1, draw two arrows to show the directions of the forces due to the pressures on the top of the oil-drum and on the base of the oil-drum. [1]
- (ii) Calculate the resultant of the two forces in (i).

resultant force =[2]

- (iii) Hence, determine the average density of the drum and its content.

density =[2]

- (b) The drum is pushed into the seawater by 5 cm and then released. It oscillates vertically. Fig. 1.2 shows the variation of its vertical displacement s with time t .

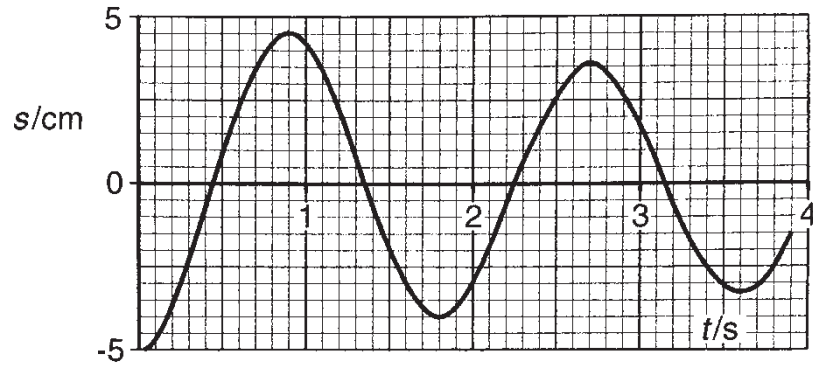

Fig. 1.2

- (i) Describe how you would use the graph of Fig. 1.2 to determine the maximum vertical speed of the oil drum.

.....
 [1]

- (ii) Explain why the amplitude of the oscillations is not constant.

.....
 [1]

- A2** A coil of about 1500 turns of insulated wire is tightly wound on a non-magnetic tube to make a solenoid of mean radius 22 mm, as shown in Fig. 2.1. The total length of the wire in the coil is 207 m. The wire itself has radius 0.86 mm and is made of a material of resistivity $1.7 \times 10^{-8} \Omega \text{ m}$. The coil is connected to a supply of e.m.f. 12 V.

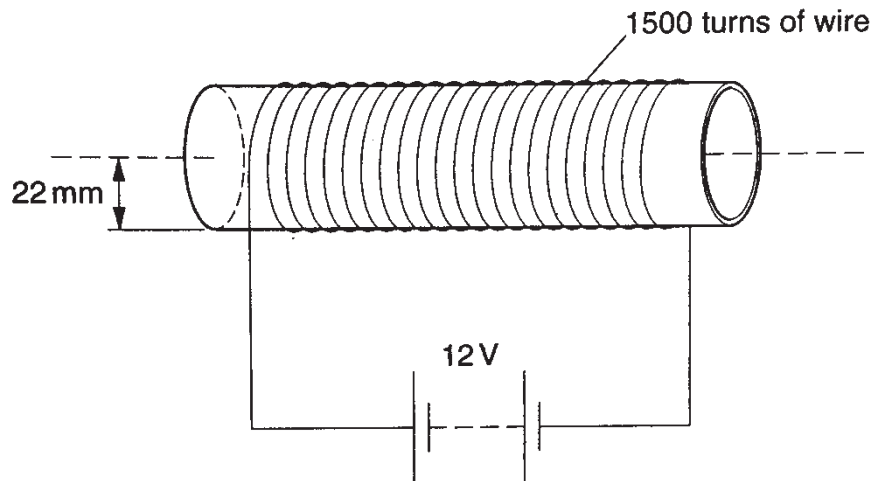

Fig. 2.1

(a) Calculate

- (i)** the total resistance of the coil,

resistance =[2]

- (ii)** the current in the coil.

current =[1]

- (b)** On Fig. 2.1, draw the pattern of the magnetic field within and around the solenoid. Use arrows to show the direction of the field inside the solenoid. [2]

- (c) A U-shaped piece of stiff wire ABCDEF pivoted at BE is inserted into the solenoid, as shown in Fig. 2.2.

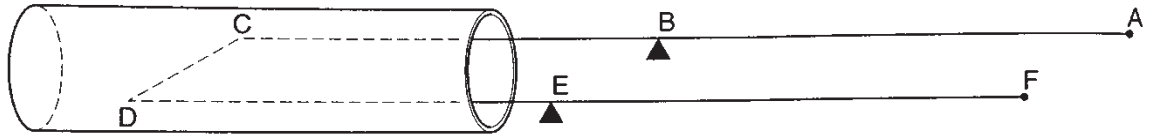

Fig. 2.2

CD has length 25 mm, CB and DE each have length 106 mm.

The stiff wire is first balanced when there is no current in it. A current is then passed through CD and, in order to rebalance the stiff wire, a force of 5.7×10^{-4} N is applied at a distance of 77 mm from the pivot, as shown from the side view in Fig. 2.3.

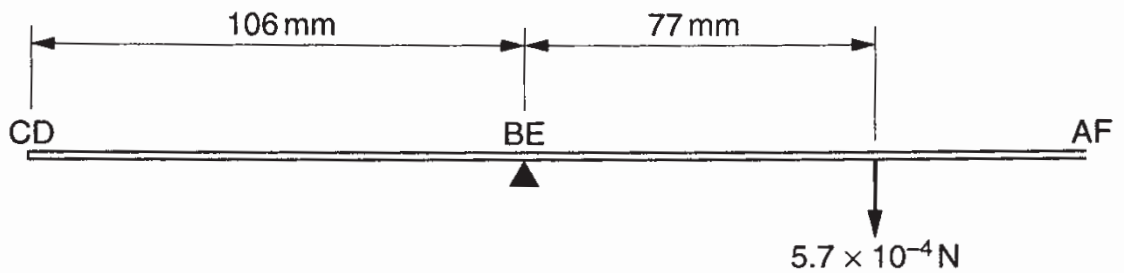

Fig. 2.3

- (i) State the direction of current flow in CD.
 [1]

- (ii) Calculate the magnetic force on CD.

magnetic force =[2]

A3 (a) Give one difference between the two methods of heat transfer: conduction and convection.

.....
..... [1]

(b) Explain the following in terms of heat transfer.

(i) When touched, an empty metal cup as shown in Fig. 3.1 feels cold, whereas it feels hot when it contains hot coffee.



Fig. 3.1

.....
.....
.....
.....
..... [2]

(ii) A double-walled glass as shown in Fig. 3.2 used to serve hot tea does not feel hot when it is being held by the hand.



Fig. 3.2

.....
.....
..... [2]

- A4** Steve wants to find out how much ice is needed to extract the same amount of energy from a room as an air conditioner.

An air conditioner unit of 2 kW is switched on for 24 hours to cool a room to 25 °C.

- (a) (i) Calculate the amount of thermal energy extracted from the room by the air conditioner in the 24 hours.

thermal energy =[1]

- (ii) State two assumptions that Steve has made in his calculations.

1.

.....

2.

..... [2]

- (b) Calculate the mass of ice at 0 °C needed to extract the same amount of energy as the air conditioner to reach the room temperature of 25 °C.
(The specific heat capacity of water is 4 200 J/(kg °C) and the specific latent heat of ice is 340 000 J/kg.)

mass of ice =[2]

A5 Fig. 5.1 shows an incorrect electromagnetic spectrum drawn by a student. The components of the spectrum and the wavelengths are in the wrong order. The values of the wavelengths do not match the correct components of the spectrum.

short wavelength						long wavelength
microwaves	radio waves	ultraviolet	infra-red	gamma rays	X-rays	visible
10^3 m	10^{-14} m	10^{-10} m	10^{-8} m	10^{-2} m	10^{-6} m	10^{-5} m

Fig. 5.1

(a) On Fig. 5.2, complete the table of the electromagnetic spectrum in the correct order of the various components and their corresponding wavelengths.

short wavelength						long wavelength

Fig. 5.2

[2]

(b) State the speed of all electromagnetic waves in a vacuum.

speed =[1]

(c) State one other property, other than speed, that all electromagnetic waves have in common.

..... [1]

(d) Name one effect of absorption of electromagnetic waves by humans.

.....
 [1]

A6 Fig. 6.1 shows a converging lens, of focal length 10 cm, being used as a simple magnifying glass. A virtual image is formed 25 cm from the lens.

The scale used in Fig. 6.1 is 1 cm : 5 cm.

(a) On Fig. 6.1, complete the ray diagram to determine the position of the object.

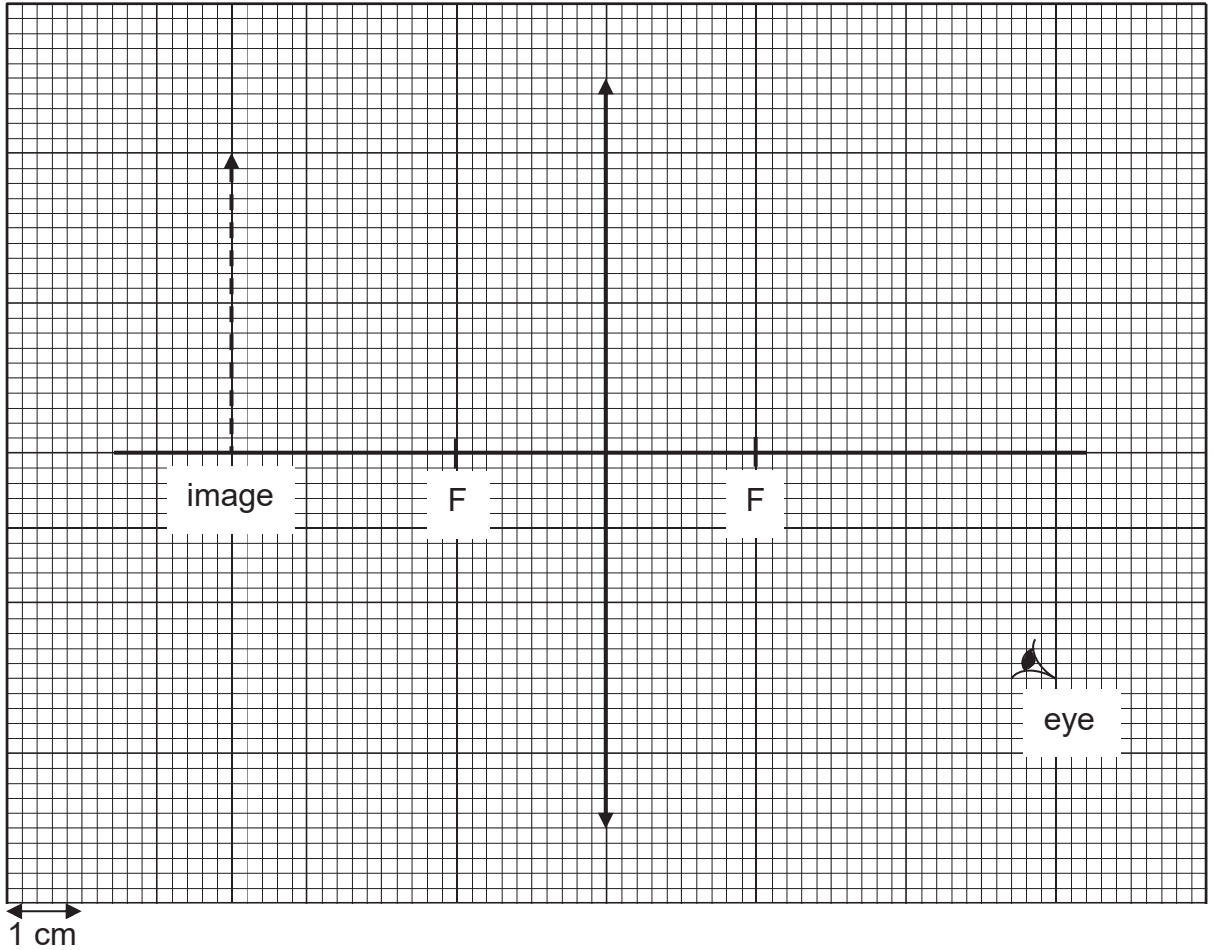

Fig. 6.1

[3]

(b) State two ways in which the image formed by a converging lens used in a camera differs from that formed by a plane mirror.

.....

..... [1]

- (c) Fig. 6.2 shows an image seen behind a mirror at 25 cm from the mirror. The scale used is 1 cm : 5 cm.

By drawing two rays of light, show how the points P and Q are being formed as seen by an observer E. Show clearly the position of the object, labelled R and S.

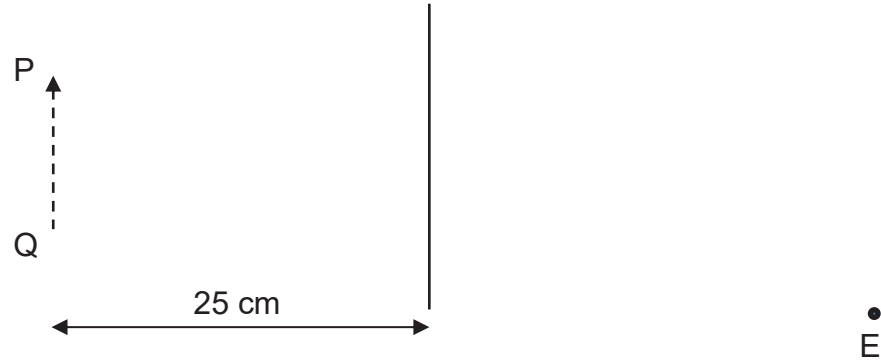

Fig. 6.2

[3]

- A7** A negatively charged rod is brought near two neutral isolated balls X and Y. Ball X is then earthed momentarily as shown in Fig. 7.1.

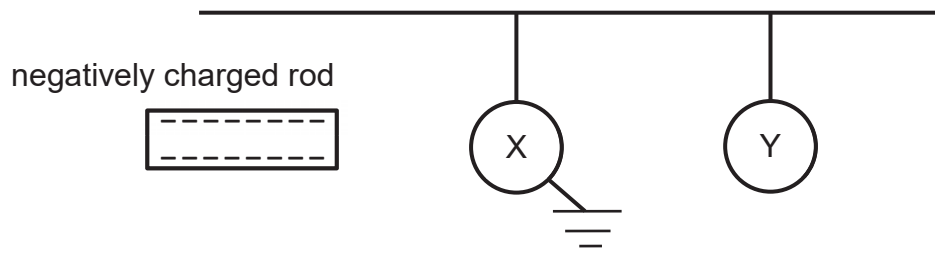

Fig. 7.1

- (a)** Describe and explain what happens to the two balls when the negatively charged rod is first brought near to them. You are to assume that the balls and rod do not come into contact.

.....

.....

.....

.....

.....

..... [2]

- (b) (i)** Describe what happens to the charges of ball X when it is earthed momentarily.

.....

.....

..... [1]

- (ii) On Fig. 7.2, draw the positions of the two balls and indicate their charges, if any, when ball X is earthed momentarily.

negatively charged rod



Fig. 7.2

[1]

- (c) State the charges of the two balls when the rod is removed.

.....

..... [1]

A8 A fully charged car battery has an e.m.f. of 12 V. This battery can deliver a constant current of 2.0 A for a period of 7.0 hours.

- (a) Calculate the total amount of charge passing through the battery in a time of 7.0 hours.

charge =[1]

- (b) The fully charged car battery is connected to a 0.025Ω resistor, a starter motor, four sidelights and two headlights as shown in Fig. 8.1. The starter motor is used to start the engine.

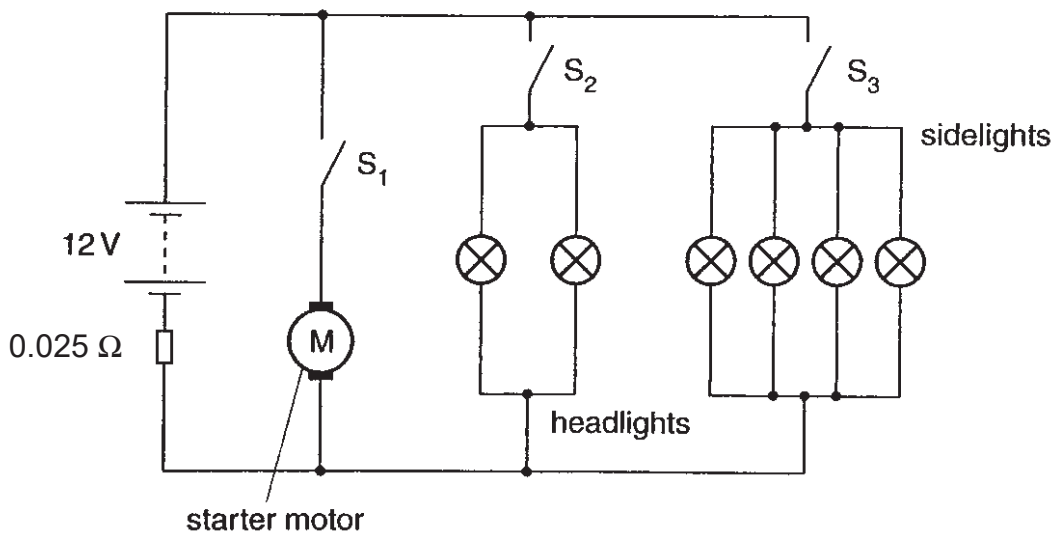

Fig. 8.1

- (i) The resistance of each headlight is 3.0Ω , and the resistance of each sidelight is 24Ω . Calculate the current in the battery when switches S_2 and S_3 are closed and switch S_1 is open.

current =[2]

- (ii) The sidelights and headlights are switched on. With S_1 closed, the current in the starter motor is 120 A. Explain why all the lights become less bright when S_1 is closed.

.....
.....
.....
..... [2]

- (c) The sidelights are accidentally left on when the car is parked at 9 pm. Determine quantitatively whether the driver is able to start the engine at 6 am the following day.

.....
..... [3]

END OF SECTION A

SECTION B

Answer **all** the questions in this section.

Answer only one of the two alternative questions in **Question 11**.

- B9** According to some scientists, battery-powered cars offered many advantages over petrol-driven cars. Rechargeable lead-acid batteries are the most common type of batteries used in cars. Fig. 9.1 shows some properties of petrol, of a particular lead-acid battery and of a typical car.

Petrol	
density	700 kg m^{-3}
chemical energy available	45 MJ kg^{-1}

Typical lead-acid battery	
energy available when fully charged	15 MJ
mass	20 kg
e.m.f.	100 V

Car	
volume of petrol tank	$4.0 \times 10^{-2} \text{ m}^3$
Efficiency of transfer of chemical energy of petrol to kinetic energy of car	25%
Drag force at 30 m s^{-1}	580 N

Fig. 9.1

- (a) Calculate the chemical energy available from a full tank of petrol.

energy =[2]

- (b) Calculate the total distance travelled by the car on a full tank of petrol when travelling at a constant speed of 30 m s^{-1} on a level road.

distance =[2]

- (c) (i) Calculate the cost of charging the battery fully if the cost of electricity is \$0.28 for one kWh.

cost =[2]

- (ii) A fully-charged battery delivers a constant current of 8.0 A. Calculate the time in hours before the battery needs to be charged again.

time =[2]

- (d) (i) Calculate the total mass of lead-acid batteries needed to provide the same energy as a full tank of petrol.

mass =[1]

- (ii) Suggest how your answer to (i) may affect the performance of a battery-powered car.

.....

..... [1]

- B10** The variation with time t of the vertical speed v of a light ball falling through air is shown in Fig. 10.1.

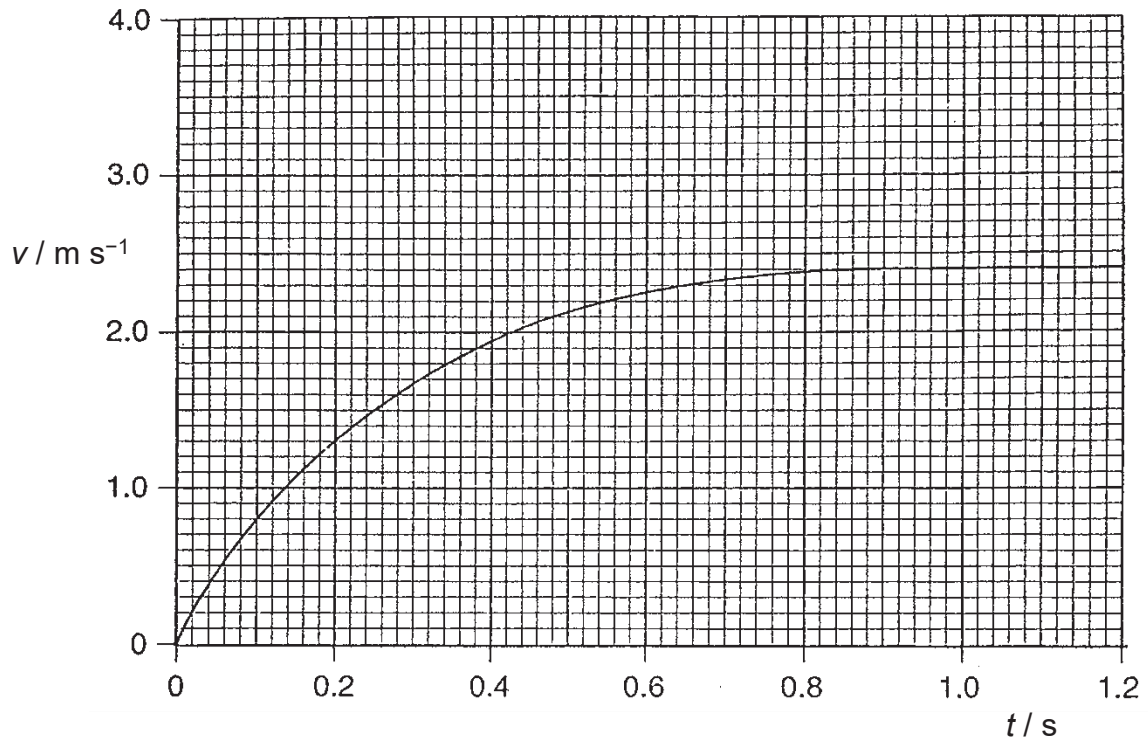

Fig. 10.1

The mass of the ball is 15 g. The gravitational field strength is 10 N kg^{-1} .

- (a) On Fig. 10.1, draw a line to show the variation with time t of the vertical speed v of the ball falling from rest in a vacuum. [1]
- (b) Use Fig. 10.1 to determine the acceleration of the ball falling through air at time $t = 0.20 \text{ s}$. Show your construction on Fig. 10.1.

acceleration =[2]

(c) For the air resistance acting on this ball, calculate

(i) the maximum resistive force,

force =[1]

(ii) the resistive force at time $t = 0.20$ s.

force =[2]

(d) The ball hits a soft ground and decelerates uniformly at 160 m s^{-2} .

Determine

(i) the time taken for the ball to come to a complete stop,

time =[2]

(ii) the distance moved by the ball in the soft ground.

distance =[2]

EITHER

- B11** Fig. 11.1 shows a coil of wire wound on a piece of soft iron. A magnet is rotated in the gap in the soft iron as shown. When the magnet rotates, the lamp connected to the coil glows.

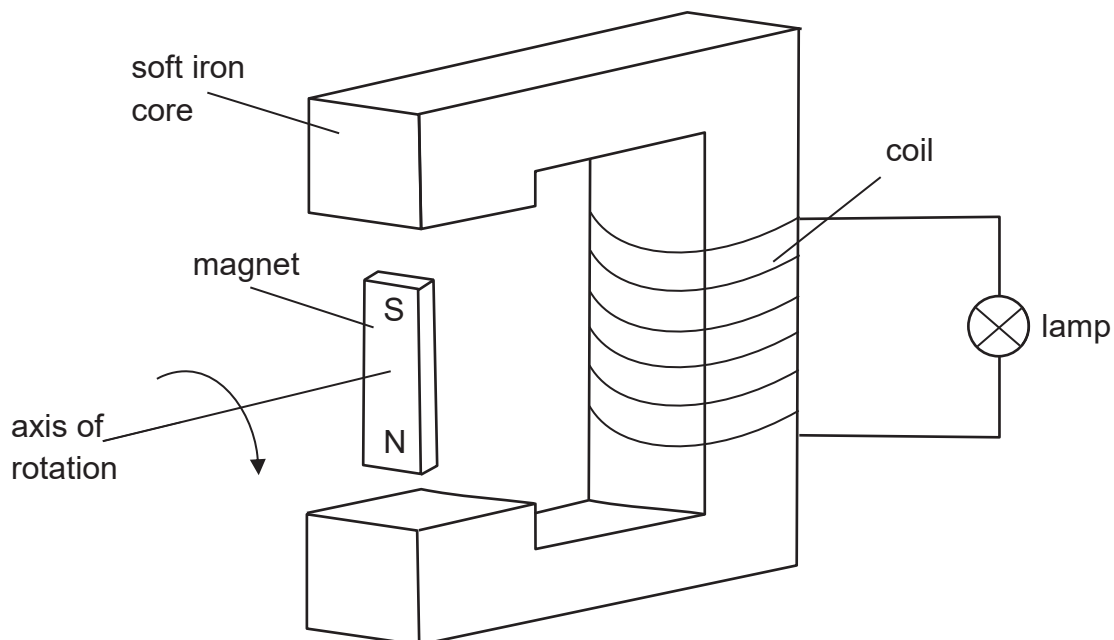

Fig. 11.1

- (a) Explain why the lamp glows when the magnet rotates.

.....

 [2]

- (b) Describe two alterations that could be made to the parts of the apparatus for the lamp to glow more brightly.

.....

 [2]

- (c) State the purpose of the soft iron core.

.....
 [1]

- (d) If the U-shaped soft iron is replaced by a piece made from wood, explain if the lamp will still glow when the magnet rotates.

.....

 [2]

- (e) The coil of wire is then wound onto the parts of the soft iron core just above and below the magnet as shown in Fig. 11.2. The magnet is again made to rotate as shown, with the S-pole moving out of the plane of the paper and the N-pole moving into the plane of the paper at the instant shown in Fig. 11.2.

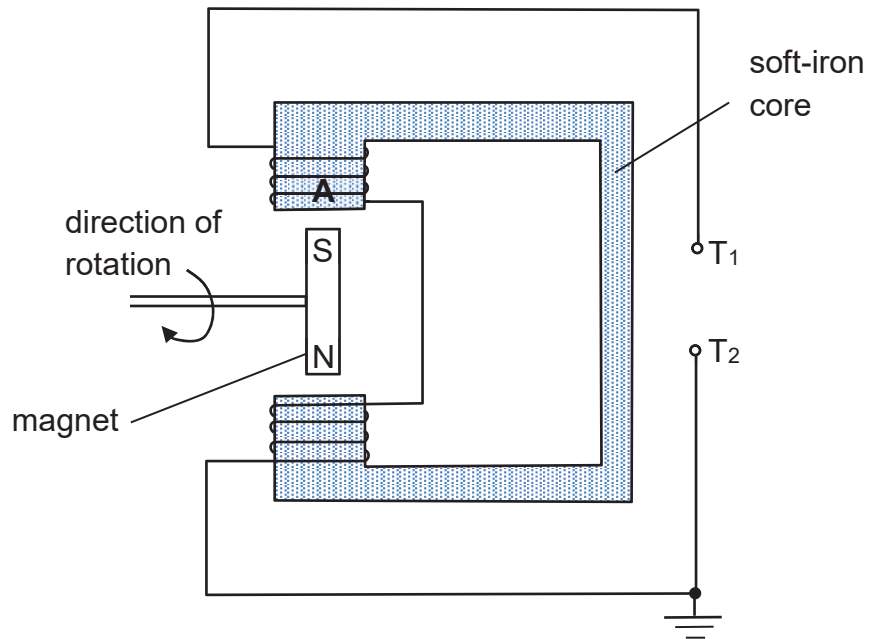

Fig. 11.2

- (i) Describe how the magnetic poles induced in part A of the core change during one rotation of the magnet.

.....

 [2]

- (ii) On Fig. 11.3, sketch the variation of the e.m.f. produced between terminals T_1 and T_2 during one rotation of the magnet. (Assume that T_2 is held at 0 V throughout the rotation.)

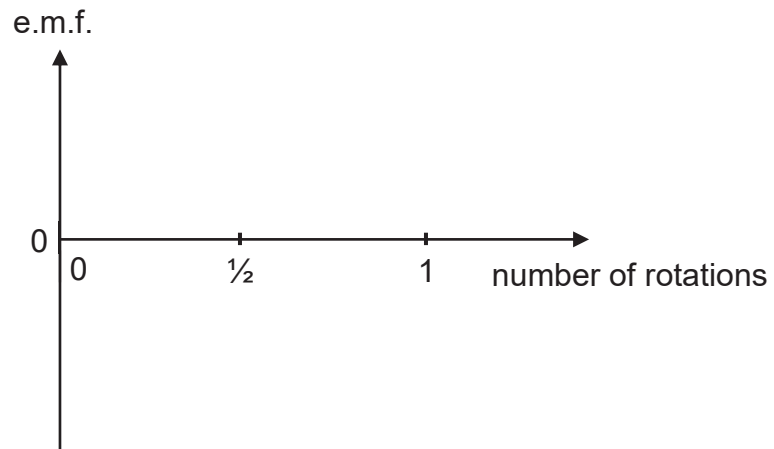

Fig. 11.3

[1]

(b) Fig. 11.5 shows the initial position of some particles before vibration begins and at different times of the sound wave.

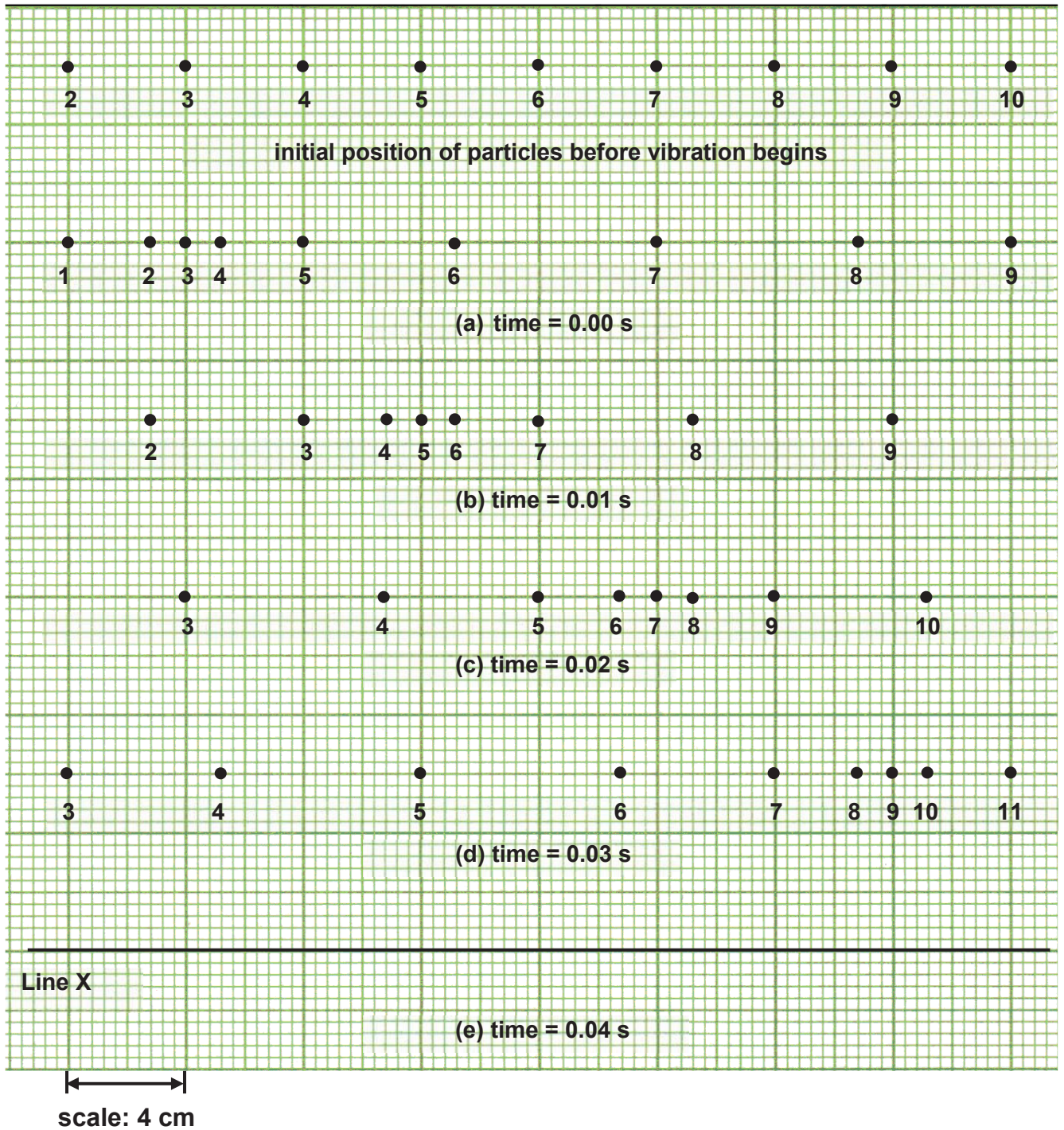

Fig. 11.5

(i) Calculate the frequency of the wave motion.

frequency =[1]

- (ii) On Fig. 11.5, mark the amplitude of the wave motion. [1]
- (iii) Using the given scale, determine the wavelength of the wave motion.

wavelength =[1]

- (iv) Hence, calculate the speed of the wave.

speed =[1]

- (v) On Fig. 11.5, draw on line X the positions of particles 3, 5, 7 and 9 at time = 0.04 s. [1]
- (vi) On Fig. 11.6, sketch a displacement-time graph of particle 5 from time 0 s to 0.03 s, taking the displacement to the right as positive. Show clearly values on both axes.

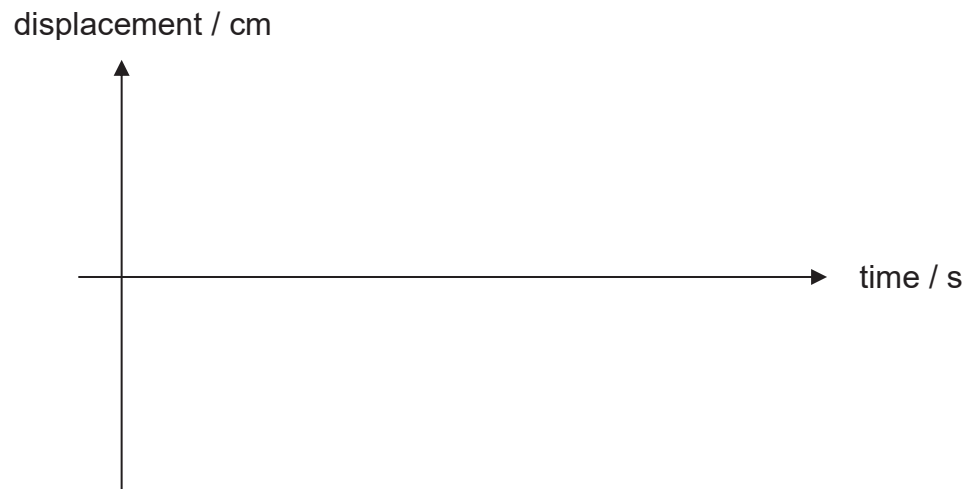

Fig. 11.6

[2]

END OF PAPER

Solutions to 2018 4E Physics Prelim

Paper 1

Multiple Choice Questions [40 marks]

1	D	11	A	21	A	31	B
2	A	12	A	22	A	32	A
3	D	13	D	23	A	33	D
4	B	14	C	24	C	34	C
5	A	15	D	25	B	35	B
6	A	16	A	26	B	36	D
7	A	17	B	27	A	37	D
8	D	18	D	28	D	38	C
9	A	19	A	29	A	39	A
10	C	20	D	30	A	40	B

Paper 2

Section A: Structured Questions [50 marks]

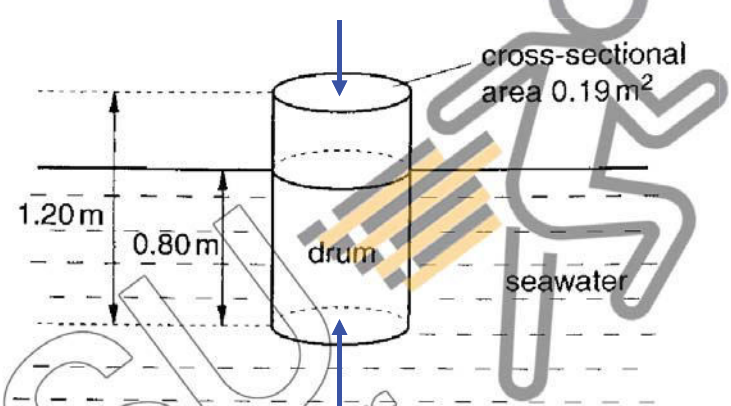
Qn	Solution	Mark
A1(a)(i)		[1] for vertical arrows drawn on the drum
A1(a)(ii)	<p>difference in pressure $= h\rho g$ $= 0.80 \times 1.1 \times 10^3 \times 10$ $= 8800 \text{ Pa}$</p> <p>resultant force $= 8800 \times 0.19$ $= 1672 \text{ N}$ $\approx 1670 \text{ N}$</p>	[1] [1]
A1(a)(iii)	<p>weight of drum and its content = 1672 N</p> <p>average density $= \frac{m}{V}$</p>	[1]

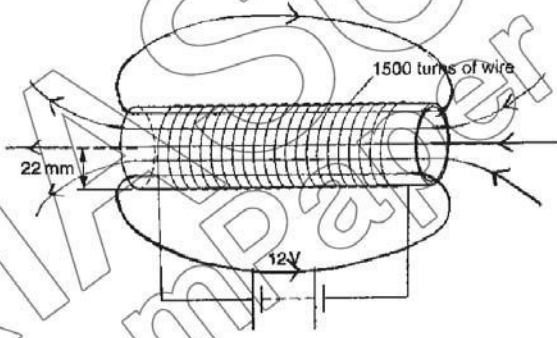
	$\frac{1672}{10}$ $= \frac{1.20 \times 0.19}{1.20 \times 0.19}$ $\approx 733 \text{ kg m}^{-3}$	[1]
A1(b)(i)	Determine the <u>gradient at the steepest part of the graph</u> , where $s = 0 \text{ cm}$.	[1]
A1(b)(ii)	There is work done against the resistive force due to water.	[1]
A2(a)(i)	<p>total resistance</p> $= \rho \frac{L}{A}$ $= 1.7 \times 10^{-8} \times \frac{207}{\pi \times (0.86 \times 10^{-3})^2}$ $\approx 1.51 \Omega$	[1] [1]
A2(a)(ii)	<p>current = $\frac{V}{R}$</p> $= \frac{12}{1.51}$ $\approx 7.95 \text{ A}$	[1]
A2(b)	 <p style="text-align: center;">Fig. 2.1</p>	[1] for field pattern [1] for direction of field
A2(c)(i)	The current flows from C to D.	[1]
A2(c)(ii)	<p>Taking moments about the pivot,</p> <p>total anticlockwise moments = total clockwise moments</p> $F \times 106 = 5.7 \times 10^{-4} \times 77$ $F \approx 4.14 \times 10^{-4} \text{ N}$	[1] [1]
A3(a)	<p>Conduction involves vibrations of particles (without any flow of medium) while convection involves movements of molecules (due to difference in density)</p> <p>Accept: Conduction occurs <u>mainly</u> in solids while convection occurs only in liquids and gases</p>	[1]

A3(b)(i)	Metal is a good conductor of heat. Heat from the hand is conducted <u>away</u> easily on touching an empty metal cup, hence feeling cold; whereas <u>heat from the hot coffee is conducted from the hot coffee to the hand easily</u> when the cup contains hot coffee, hence feeling hot.	[1] [1]																					
A3(b)(ii)	The double-walled glass has air in between the walls. <u>Air is a bad conductor of heat and so heat from the hot tea is not easily transferred to the hand</u> , hence does not feel hot.	[1] [1]																					
A4(a)(i)	Energy = Power x time = 2000 x 24 x 3600 = 172,800,000 J = 173 MJ (3 sf)	[1]																					
A4(a)(ii)	1. Objects in the room do not release or absorb any thermal energy to or from the room. 2. The air conditioner is 100% efficient.	[1] [1]																					
A4(b)	$Q = ml + mc\Delta\theta$ $173 \text{ MJ} = m \times 340\,000 + m \times 4200 \times (25 - 0)$ $173\,000\,000 = 340\,000 m + 105\,000 m$ $173\,000\,000 = 445\,000 m$ $m = 389 \text{ kg}$	[1] for working [1] for answer																					
A5(a)	<table border="1" style="width: 100%; text-align: center;"> <thead> <tr> <th colspan="4" style="text-align: left;">short wavelength</th> <th colspan="3" style="text-align: right;">long wavelength</th> </tr> </thead> <tbody> <tr> <td><i>gamma rays</i></td> <td><i>X-rays</i></td> <td><i>ultraviolet</i></td> <td><i>visible</i></td> <td><i>infra-red</i></td> <td><i>microwaves</i></td> <td><i>radio waves</i></td> </tr> <tr> <td>10^{-14} m</td> <td>10^{-10} m</td> <td>10^{-8} m</td> <td>10^{-6} m</td> <td>10^{-5} m</td> <td>10^{-2} m</td> <td>10^3 m</td> </tr> </tbody> </table>	short wavelength				long wavelength			<i>gamma rays</i>	<i>X-rays</i>	<i>ultraviolet</i>	<i>visible</i>	<i>infra-red</i>	<i>microwaves</i>	<i>radio waves</i>	10^{-14} m	10^{-10} m	10^{-8} m	10^{-6} m	10^{-5} m	10^{-2} m	10^3 m	[1] for all correct order of components [1] for all correct corresponding wavelength
short wavelength				long wavelength																			
<i>gamma rays</i>	<i>X-rays</i>	<i>ultraviolet</i>	<i>visible</i>	<i>infra-red</i>	<i>microwaves</i>	<i>radio waves</i>																	
10^{-14} m	10^{-10} m	10^{-8} m	10^{-6} m	10^{-5} m	10^{-2} m	10^3 m																	
A5(b)	$3.0 \times 10^8 \text{ m/s}$	[1]																					
A5(c)	They are all transverse waves; carry no electric charge; obey the laws of reflection and refraction.	[1] any one property																					
A5(d)	Causes ionisation in living cells; destruction or modification of living tissues; infra-red heating	[1] any one effect																					

A6(a)

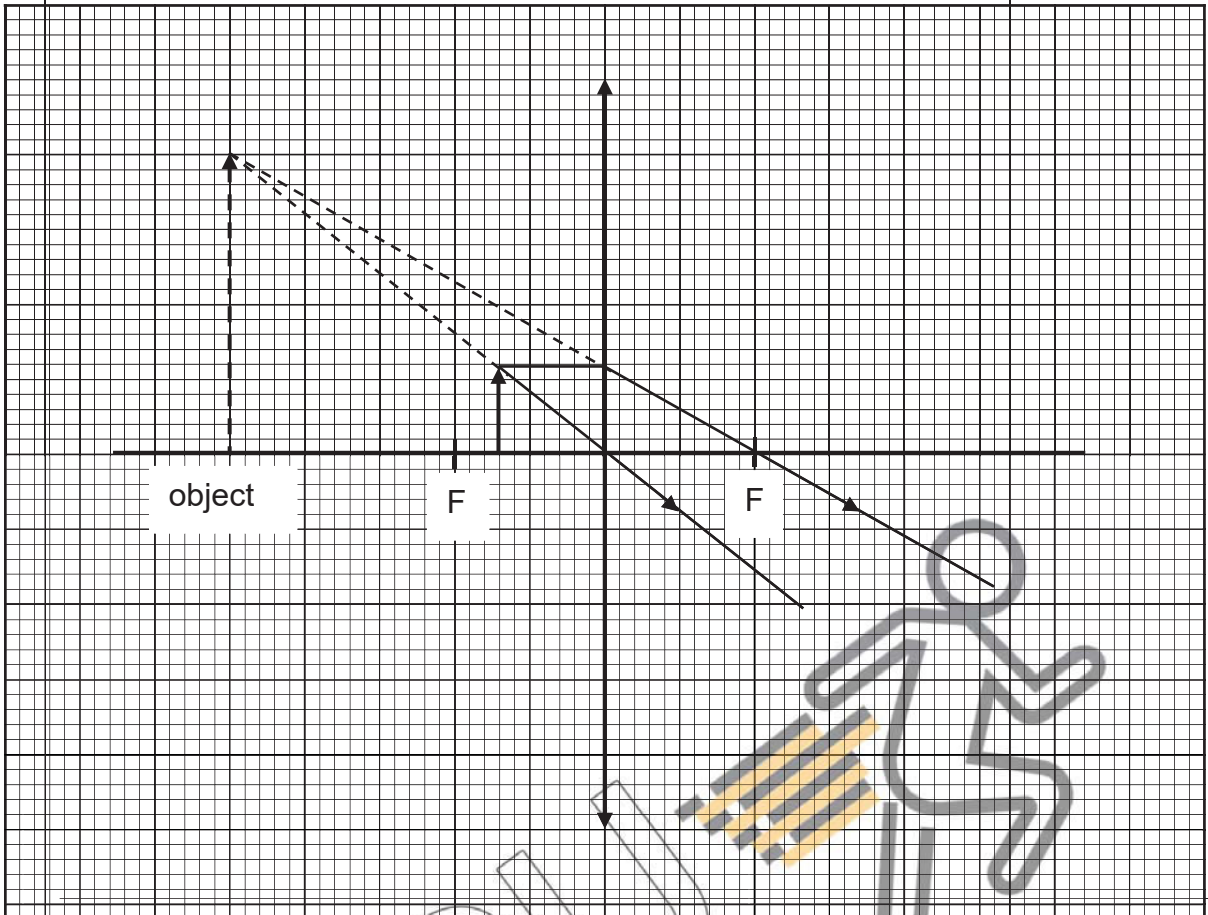

[2] 1 mark for each ray of light
 [1] position of object (6 to 8 cm from lens)

A6(b)

Converging Lens (Camera): diminished, real, inverted
 Plane mirror: same size, virtual, upright

[1] 1 mark for any 2 correct corresponding characteristics

A6(c)

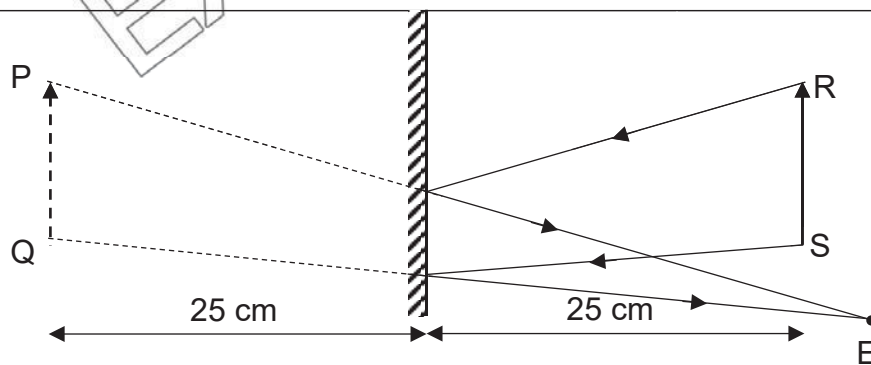

[1] correct two rays of light to eye
 [1] correct two rays from object
 [1] position of object with correct rays drawn from them.
 (25 cm from mirror)

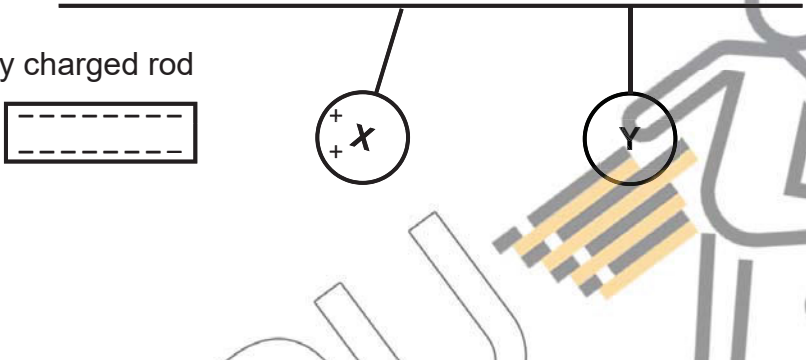
A7(a)	<p>When the rod is brought near to the balls, <u>X moves towards the rod and Y moves towards X</u>. When the negatively charged rod is brought near to X, the charges of X are induced with <u>negative charges of X repelled to the far end</u>, nearer to Y, leaving behind the <u>positive charges of X nearer to the rod</u>. This is due to <u>like charges repel</u>. With the negative charges near to Y, the charges of Y are also induced such that the <u>negative charges in Y are repel away from X</u>, leaving <u>positive charges near to X</u>, making <u>Y moves towards X as unlike charges attract</u>.</p>	<p>[1] description of position of the 2 balls and charges in X and Y [1] explanation with clear concepts</p>
A7(b)(i)	<p>The <u>negative charges of X flow down to earth and the positive charges remain attracted</u> to the negative charges of the rod.</p>	<p>[1] in describing both positive and negative charges of X</p>
A7(b)(ii)	<p>negatively charged rod</p> 	<p>[1] correct positions of X and Y and correct charges shown</p>
A7(c)	<p>X is positively charged and Y is neutral.</p>	<p>[1] correct for both X and Y</p>
A8(a)	<p>$Q = It$ $Q = 2.0 \times 7.0 \times 3600$ $Q = 50400 \text{ C}$</p>	<p>[1]</p>
A8(b)(i)	<p>total resistance across headlights and sidelights</p> $= \left(\frac{2}{3.0} + \frac{4}{24} \right)^{-1}$ $= 1.2 \Omega$ <p>total resistance in circuit</p> $= 1.2 + 0.025$ $= 1.225 \Omega$ <p>total current in the battery</p> $= \frac{12}{1.225}$ $\approx 9.80 \text{ A}$	<p>[1] [1]</p>
A8(b)(ii)	<p>The total current in the battery increases from 9.80 A to more than 120 A, and there is a <u>larger potential difference across the 0.025 resistor</u>. Hence, the <u>potential difference across the headlights and sidelights decreases</u>, and the <u>power developed decreases</u> as well. Hence, the lights become less bright.</p>	<p>[1] [1]</p>

A8(c)	Total energy used $= \frac{12^2}{6.0 + 0.025} \text{ W} \times 9 \text{ h}$ $\approx 0.215 \text{ kWh}$	[1]
	Total energy supplied by fully charged battery $= 2.0 \times 12 \text{ W} \times 7.0 \text{ h}$ $\approx 0.168 \text{ kWh}$	[1]
	The battery will be depleted and the driver <u>will not be able to start the engine.</u>	[1]

Section B: Structured Questions [30 marks]

Qn	Solution	Mark
B9(a)	mass of fuel = ρV $= 700 \times 4.0 \times 10^{-2}$ $= 28 \text{ kg}$	[1]
	chemical energy = $45 \times 10^6 \times 28$ $= 1.26 \times 10^9 \text{ J}$	[1]
B9(b)	work done by $F_{\text{driving}} = \frac{25}{100} \times 1.26 \times 10^9$ $F_{\text{driving}} \times d = 3.15 \times 10^8$	[1]
	Since car is travelling at a constant speed, $F_{\text{driving}} = F_{\text{drag}}$, $580 \times d = 3.15 \times 10^8$ $d \approx 5.4 \times 10^5 \text{ m}$	[1]
B9(c)(i)	cost = $\frac{15 \times 10^6}{3600 \times 10^3} \times \0.28 $\approx \$1.17$	[1] [1]
	B9(c)(ii) $E = P \times t$ $15 \times 10^6 = 8.0 \times 100 \times t$ $t = 18750 \text{ s}$ $t \approx 5.21 \text{ hours}$	[1] [1]
B9(d)(i)	mass required = $\frac{1.26 \times 10^9}{15 \times 10^6} \times 20$ $= 1680 \text{ kg}$	[1]
B9(d)(ii)	It will have a very large inertia and is difficult to accelerate.	[1] any reasonable answer

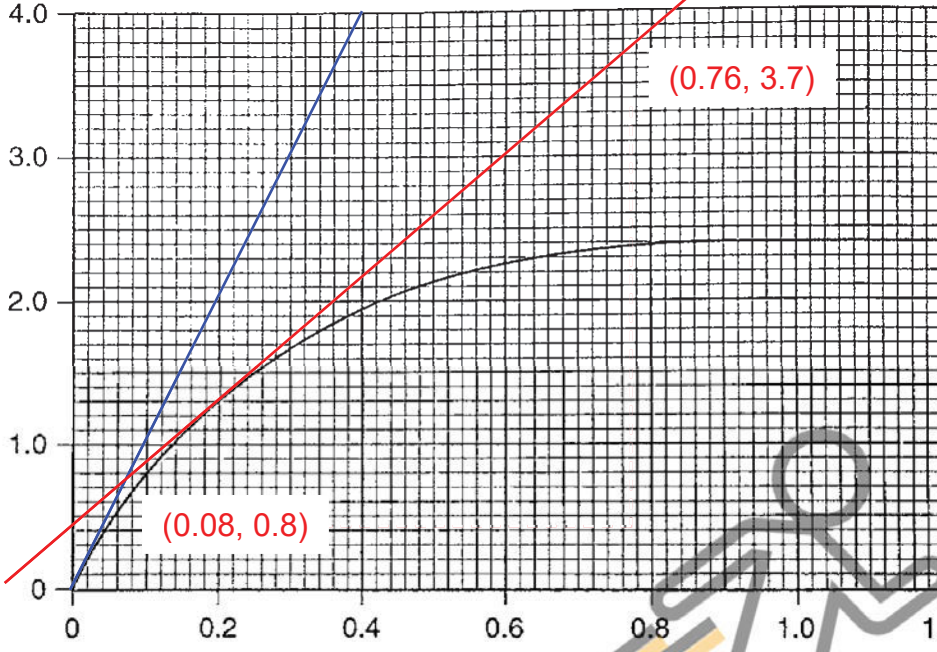
B10(a)	 <p>[1] for drawing line that cuts through (0, 0) and (0.4, 4.0)</p>	
B10(b)	$\text{acceleration} = \frac{3.7 - 0.8}{0.76 - 0.08}$ $\approx 4.26 \text{ m s}^{-2}$	[1] for drawing tangent and labelling gradient coordinates [1] for answer
B10(c)(i)	$\text{maximum resistive force} = W$ $= 15 \times 10^{-3} \times 10$ $= 0.15 \text{ N}$	[1]
B10(c)(ii)	$W - F_R = ma$ $(0.015 \times 10) - F_R = 0.015 \times 4.26$ $F_R \approx 0.0860 \text{ N}$	[1] [1]
B10(d)(i)	$a = \frac{v - u}{t}$ $-160 = \frac{0 - 2.4}{t}$ $t = 0.015 \text{ s}$	[1] [1]
B10(d)(ii)	$\text{distance travelled}$ $= \text{area under } v-t \text{ graph during deceleration}$ $= \frac{1}{2} \times 0.015 \times 2.4$ $= 0.018 \text{ m}$	[1] [1]
Either B11(a)	When the magnet rotates, there is an induced e.m.f. generated at the coils (producing a current in the lamp) due to the changing magnetic flux linkage produced at the coils.	[1] [1]

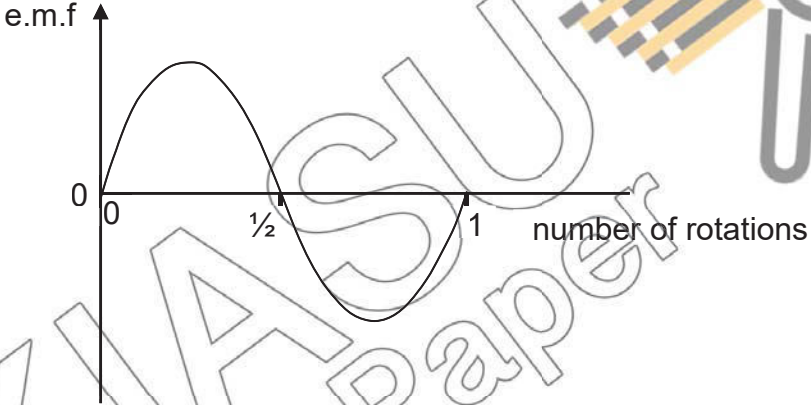
B11(b)	Wind more turns of the coil Rotate the magnet faster Use a stronger magnet	[2] for any alterations
B11(c)	The soft iron core will concentrate the magnetic field produced by the coil	[1]
B11(d)	The lamp will still glow but weakly because there will still be changing magnetic flux linkage but poor flux linkage at the coil as wood is not a soft magnetic material.	[1] [1]
B11(e)(i)	As the S-pole moves away from part A, the end of the part A acquires N-polarity. As the N-pole approaches this part, it remains North pole. As N-pole of the magnet moves away from part A, the end of part A acquires S-polarity until S-pole of the magnet reaches part A again.	[1] for the correct polarity when moving away or approaching A [1] for the full description of one rotation of the magnet
B11(e)(ii)		[1] for correct shape and symmetry, with change in direction after half of the rotation
OR B11(a)	When the ruler vibrates, the air particles are set in <u>oscillation</u> , with the <u>vibration</u> of air particles near to the ruler that cause oscillation in the <u>adjacent particles</u> . Due to the <u>vibration of particles in a direction parallel to the wave travel</u> , some regions experience a <u>higher</u> density at any instant, while other regions experience a <u>lower</u> density. This sets up regions of <u>compression and rarefaction</u> and sound energy is transmitted to the ears.	[1] [1] [1]
B(11)(b)(i)	$T = 0.04 \text{ s}$ $f = \frac{1}{T} = \frac{1}{0.04} = 25 \text{ Hz}$	[1]

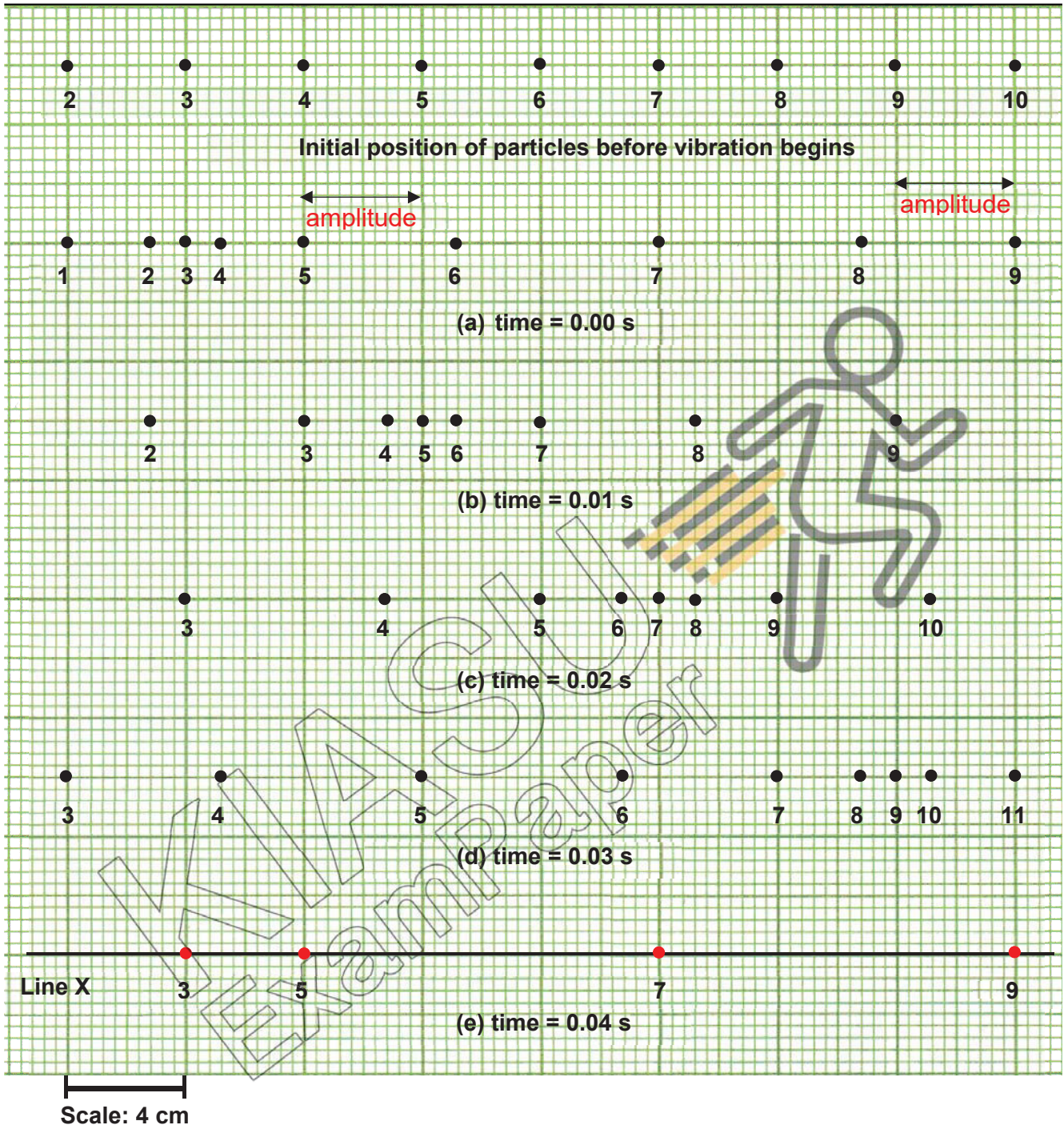

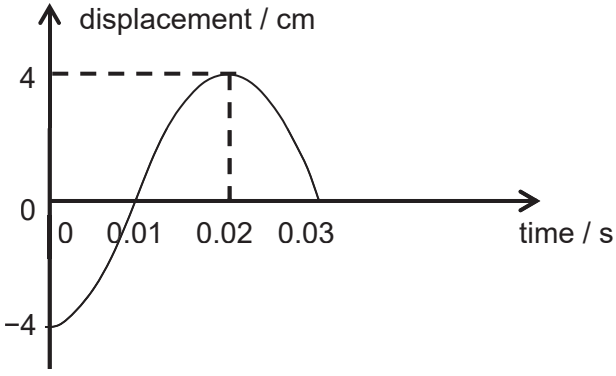
B11(b)(iii)	Wavelength (particle 3 to particle 7 shows half wavelength) = $4 \times 0.04 \text{ m} \times 2 = 0.32 \text{ m}$ or 32 cm	[1]
B11(b)(iv)	Velocity = frequency \times wavelength = $25 \times 0.32 = 8.0 \text{ m/s}$ or 800 cm/s	[1]
B11(b)(v)	Correct positions of particles 3, 5, 7 and 9	[1] for all correct positions
B11(b)(vi)		[1] correct waveform [1] correct labelling of both axes

 KIASU
 ExamPaper

