



**CATHOLIC HIGH SCHOOL  
SEMESTRAL ASSESSMENT 1  
2013  
PRIMARY THREE**

**SCIENCE**

**BOOKLET A**

Name: \_\_\_\_\_ ( )

Class: Primary 3 - \_\_\_\_\_

Date: 22 May 2013

30 questions

60 marks

Total Time for Booklets A & B: 1 hour 30 minutes

**Instructions to Candidates**

Do not turn over this page until you are told to do so.

Follow all instructions carefully.

Answer all questions.

Shade your answers in the Optical Answer Sheet (OAS) provided.

This booklet consists of 15 printed pages, excluding cover page.

**Booklet A (30 × 2 marks)**

For each question from 1 to 30, four options are given. One of them is the correct answer. Make your choice (1, 2, 3 or 4). Shade your answer on the Optical Answer Sheet. (60 marks)

---

1. Which one of the following groups consists of only non-living things?

- (1) Fan, plant, rain
- (2) Air, candle, girl
- (3) Ant, grass, water
- (4) Rain, cloud, smoke

2. Study the objects below carefully.

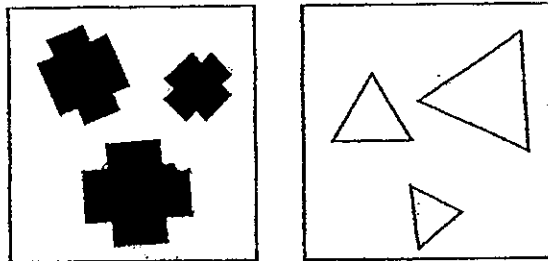

The objects above are grouped according to their \_\_\_\_\_.

- A : sizes
- B : shapes
- C : colours

- (1) A and B only
- (2) A and C only
- (3) B and C only
- (4) A, B and C

3. Look at the classification chart below.

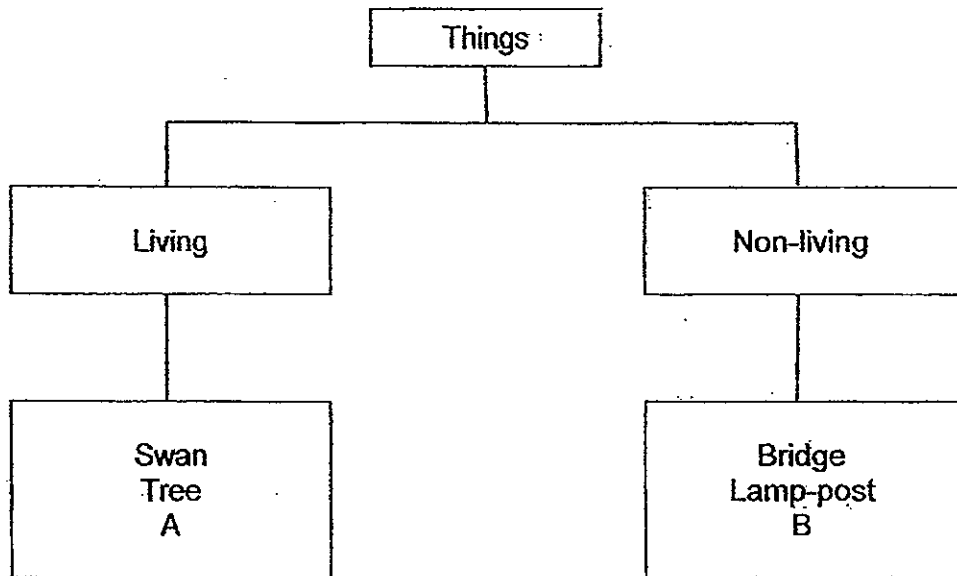

What do A and B best represent?

	A	B
(1)	Stone	Ant
(2)	Squirrel	Grass
(3)	Butterfly	Chair
(4)	Dried leaf	Bench

4. The table below shows some information about an organism.

Week	Height cm
1	10
2	20
3	30

Based on the table above, what can you say about the organism?

- (1) The organism is dead after 3 weeks.
- (2) The organism is growing as the weeks go by.
- (3) The organism is reproducing as the weeks go by.
- (4) The organism is moving over a distance as the weeks go by.

5. Study the four statements made by four children below.

- Aaron All living things need air.  
Benny All living things need food.  
Caleb All living things need water.  
Dann All living things need sunlight.

Who have made a correct statement?

- (1) Aaron and Benny only
  - (2) Caleb and Dann only
  - (3) Aaron, Benny and Caleb only
  - (4) Aaron, Benny and Dann only
6. A month ago, Nelson had only 7 guppies in his fish tank. Now, he has 15 guppies in his fish tank although he did not buy any new fish. Which one of the following statements best explains the increase of guppies in Nelson's fish tank?
- (1) Guppies reproduce to respond to changes in their surroundings.
  - (2) Guppies can move on their own to escape from danger and to look for food.
  - (3) Guppies reproduce by laying eggs to ensure that their kind will not become extinct.
  - (4) Guppies give birth to their young alive to ensure that their kind will not become extinct.
7. Read the 3 statements below carefully.
- The bird flew away when a gunshot was fired.
  - Henry laughed loudly when his friend tickled him.
  - The mimosa plant folded its leaves when someone touched it.

The above examples show that living things \_\_\_\_\_.

- (1) can grow
- (2) can move
- (3) need air, food and water
- (4) can respond to changes

8. Study the table below carefully.

Which one of the following is most likely a non-living thing?

	Can move from place to place	Needs air, food and water	Can reproduce
(1)	✓		
(2)	✓	✓	✓
(3)	✓	✓	✓
(4)		✓	✓

9. Some animals are put into groups as shown below.

J	K	L	M
lion	hen	goldfish	fly
dog	parrot	guppy	grasshopper
bat	sparrow	shark	butterfly

Look at the animal shown below.

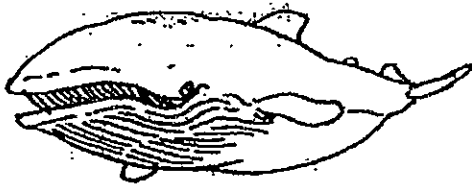

In which group would you put this animal?

- (1) J
- (2) K
- (3) L
- (4) M

10. Study the classification chart below.

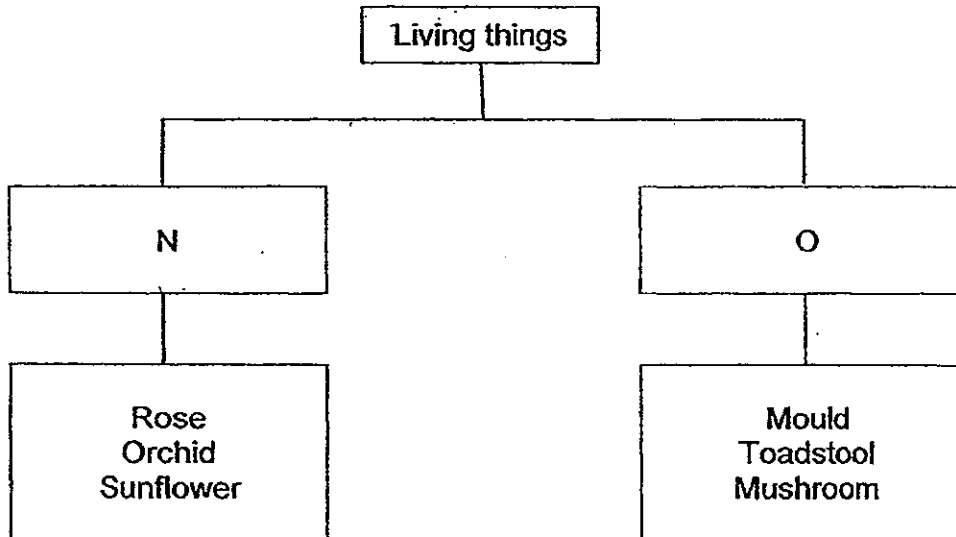

Which of the following gives the most suitable headings for both Groups N and O?

	N	O
(1)	Flowering plants	Fungi
(2)	Flowering plants	Micro-organism
(3)	Non-flowering plants	Yeast
(4)	Non-flowering plants	Micro-organism

11. Look at the classification chart below.

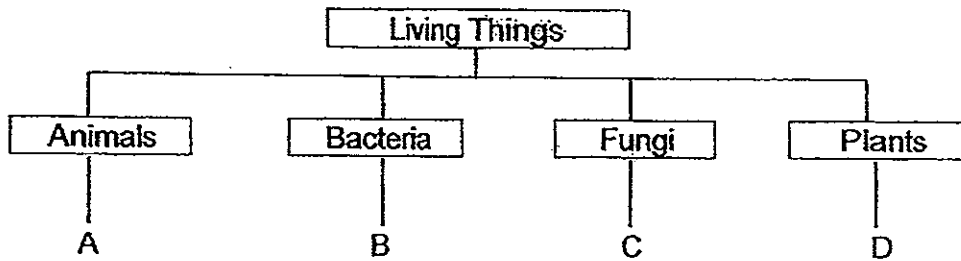

What do A, B, C and D best represent?

	A	B	C	D
(1)	monkey	earthworm	yeast	rose
(2)	horse	germs	fern	orchid
(3)	moss	mould	mushroom	hibiscus
(4)	duck	germs	toadstool	sunflower

12. Which of the following living things are grouped correctly?

	Birds	Mammals	Fish	Plants
(1)	eagle	deer	shark	papaya
(2)	bat	whale	goldfish	orchid
(3)	pigeon	cat	dolphin	mushroom
(4)	toucan	dog	guppy	mould

13. Study the flowchart below carefully.

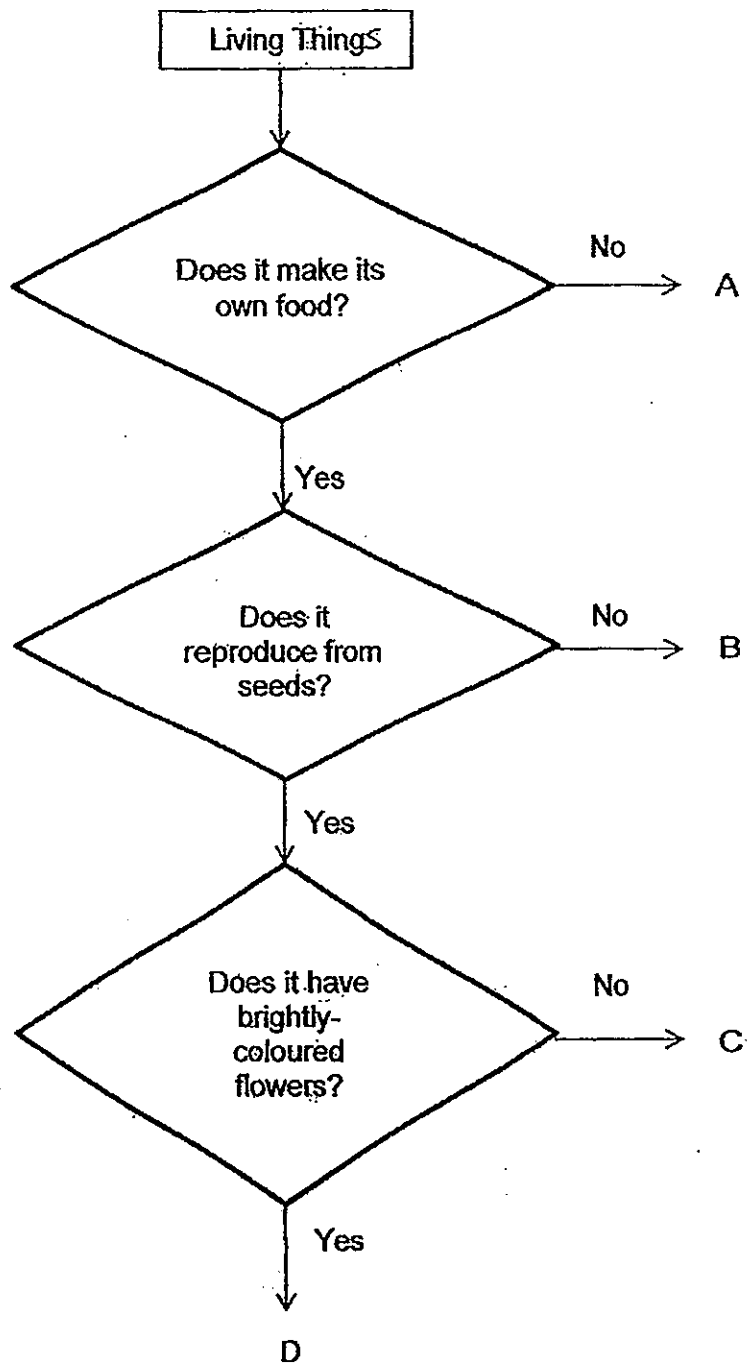

Which one of the following best represents the fern?

- (1) A
- (2) B
- (3) C
- (4) D



14. Which one of the following statements is true about all plants?

- (1) They are green,
- (2) They have flowers.
- (3) They can make food.
- (4) They reproduce from seeds.

15. The picture below shows a bird's nest fern.

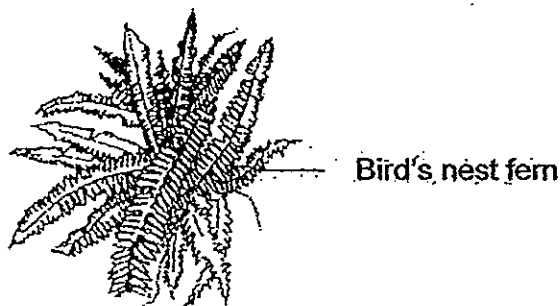

Which of the following statements below are true of the bird's nest fern?

- A : Bears flowers
- B : Makes its own food
- C : Reproduce from spores

- (1) A and B only
- (2) A and C only
- (3) B and C only
- (4) A, B and C

16. Which of the following is a difference between flowering plants and fungi?

	Flowering plants	Fungi
(1)	Poisonous	Not poisonous
(2)	Bear flowers	Do not bear flowers
(3)	Can be seen with the naked eye	Cannot be seen with the naked eye
(4)	Cannot move freely from place to place	Can move freely from place to place

17. The following four animals are grouped together.

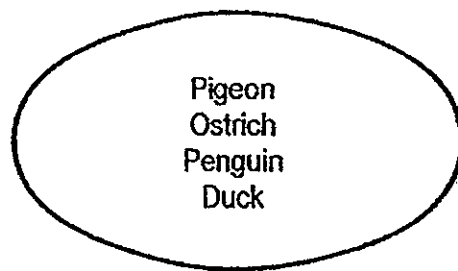

Which of the following characteristics show why they are grouped together?

- S : They can fly.
- T : They waddle and swim.
- U : They have wings and a beak.
- V : Their bodies are covered with feathers..

- (1) S only
- (2) U only
- (3) U and V only
- (4) S, T; U and V

18. Study the classification table below carefully.

Group M	Group N	Group O	Group P
Ant	Rabbit	Dolphin	Bat
Caterpillar	Kangaroo	Goldfish	Eagle

How are the animals above grouped?

- (1) By their sizes.
- (2) By the way they move.
- (3) By the way they reproduce.
- (4) By their outer body coverings.

19. In which of the following are the animals grouped correctly?

	Hair	Feathers	Scales
(1)	Penguin	Ostrich	Guppy
(2)	Dog	Bat	Guppy
(3)	Penguin	Bat	Molly
(4)	Dog	Ostrich	Molly

20. Study the flow chart below carefully.

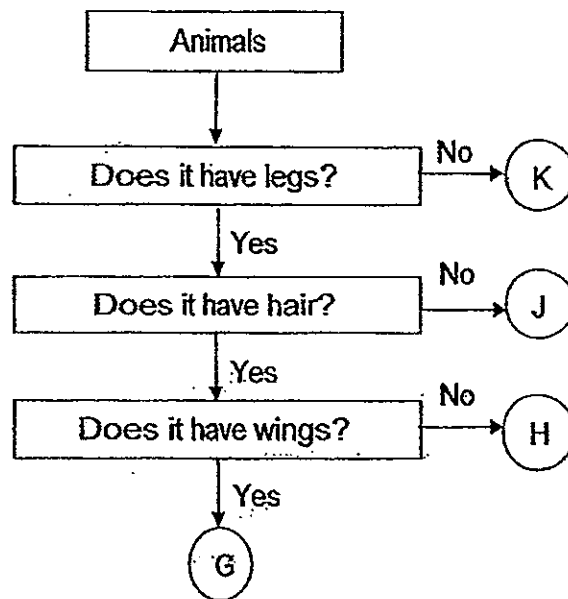

Which one of the following animals is best represented by H?

- (1) Bat
- (2) Whale
- (3) Penguin
- (4) Giraffe

21. Which one of the following is true about bacteria?

- (1) Bacteria reproduce by spores.
- (2) All bacteria are harmful to man.
- (3) Bacteria exist in different shapes.
- (4) Bacteria can only be found in very cold places.

22. Which of the following statements are true about bread mould?

- P : It reproduces by spores.
- Q : It needs water to grow.
- R : It can make its own food.

- (1) P and Q only
- (2) Q and R only
- (3) P and R only
- (4) P, Q and R

23. Look at the two organisms below.



Mushroom



Mould

How are the mushroom and mould similar?

- (1) They can move on their own.
- (2) They can make their own food.
- (3) They belong to the same group called fungi.
- (4) They do not need air, food and water to survive.

24. Some living things are classified into two groups as shown in the chart below.

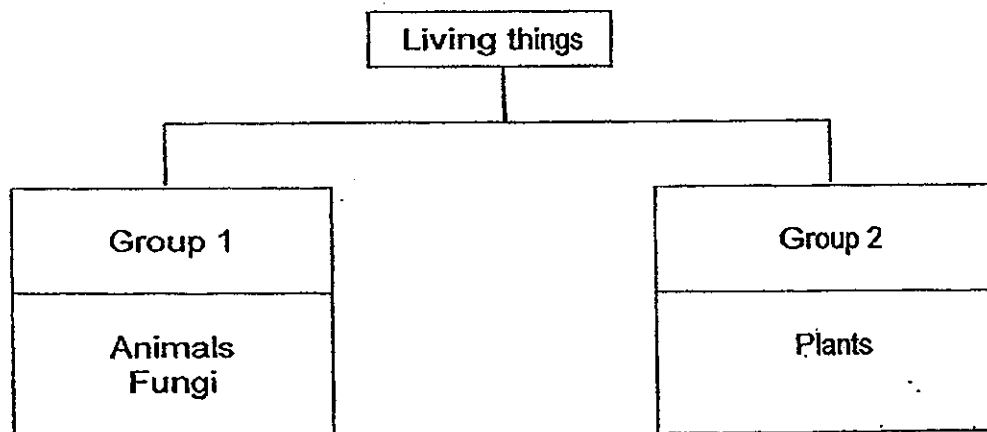

The living things are grouped according to whether they \_\_\_\_\_.

- (1) reproduce from spores or reproduce from seeds
- (2) need oxygen or do not need oxygen to stay alive
- (3) can make their own food or cannot make their own food
- (4) produce carbon dioxide or do not produce carbon dioxide

25. Object Z is used to open the lid of the tin shown below.

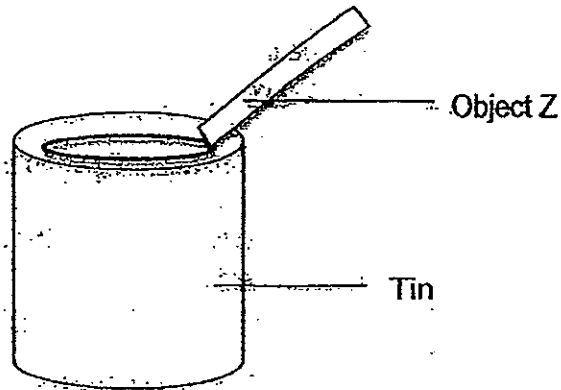

Which one of the following materials is most suitable to make Object Z?

- (1) Metal
  - (2) Glass
  - (3) Fabric
  - (4) Rubber
26. Materials used to make raincoats, umbrellas and plastic bags should be \_\_\_\_\_.

W : soft  
X : flexible  
Y : waterproof  
Z : transparent

- (1) Y only
- (2) X and Y only
- (3) W and X only
- (4) W, X, Y and Z

27. The table below shows the properties of some materials.

Material	Properties
E	<ul style="list-style-type: none"> <li>flexible</li> <li>allows light to pass through</li> </ul>
F	<ul style="list-style-type: none"> <li>flexible</li> <li>does not allow light to pass through</li> </ul>
G	<ul style="list-style-type: none"> <li>not flexible</li> <li>allows light to pass through</li> </ul>
H	<ul style="list-style-type: none"> <li>not flexible</li> <li>does not allow light to pass through</li> </ul>

Which material is most suitable for making a fish tank?

- (1) E
- (2) F
- (3) G
- (4) H

28. The diagram below shows how some objects are classified according to the materials they are made of.

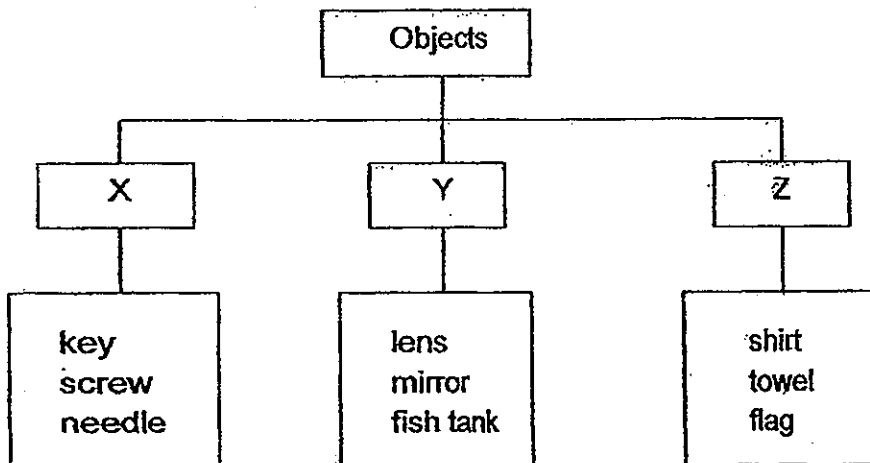

What materials do X, Y and Z represent?

	X	Y	Z
(1)	Metal	Glass	Fabric
(2)	Metal	Wood	Fabric
(3)	Plastic	Glass	Rubber
(4)	Rubber	Plastic	Paper

29. Simon tested the strength of five different materials by dropping a 1-kg weight from a height of 1 metre. All five materials have the same shape and size. He noted the number of times the weight was dropped before the material broke into two pieces.

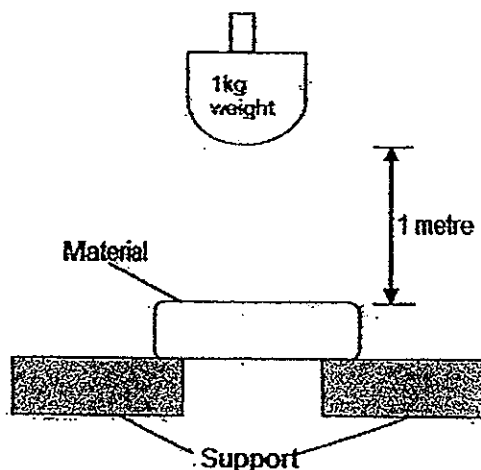

The results were shown in the table below.

Material	Number of 'drops'
P	48
Q	37
R	64
S	23
T	51

Based on the results above, which one of the following statements best describes the materials correctly?

- (1) Material T is a metal.
- (2) Material P is stronger than Material R.
- (3) Material T is hard enough to scratch Material Q.
- (4) Material S will be the first to break if a 2kg weight is dropped on it.

30. Four types of materials underwent a scratch test. The results are shown in the diagram below.

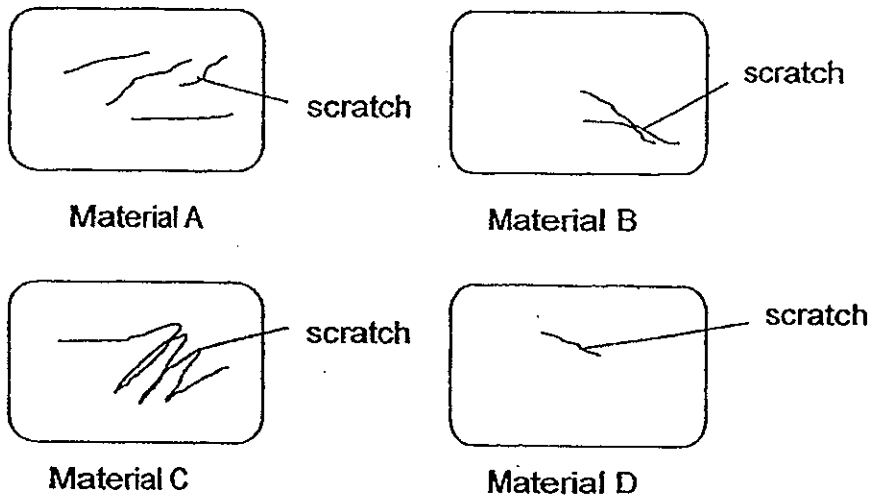

What can you conclude from the test results?

- (1) Material C is the hardest material.
- (2) Material D is the hardest material.
- (3) Material C is stronger than Material A.
- (4) Material D is stronger than Material B.

**End of Booklet A**



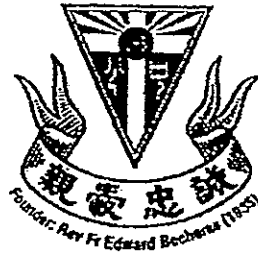

**CATHOLIC HIGH SCHOOL  
SEMESTRAL ASSESSMENT 1  
2013  
PRIMARY THREE**

**SCIENCE**

**BOOKLET B**

Name: \_\_\_\_\_ ( )

Class: Primary 3 - \_\_\_\_\_

Date: 22 May 2013

Booklet A	60
Booklet B	40
Total	100

14 questions

40 marks

Total Time for Booklets A & B: 1 hour 30 minutes

**Instructions to Candidates**

Do not turn over this page until you are told to do so.

Follow all instructions carefully.

Answer all questions.

Write your answers in this booklet.

This booklet consists of 13 printed pages, excluding cover page.

**Booklet B (40 marks)**

For questions 31 to 44, write your answers in this booklet.

The number of marks available is shown in brackets [ ] at the end of each question or part question. (40 marks)

31. Classify the following objects in the chart below. [2]

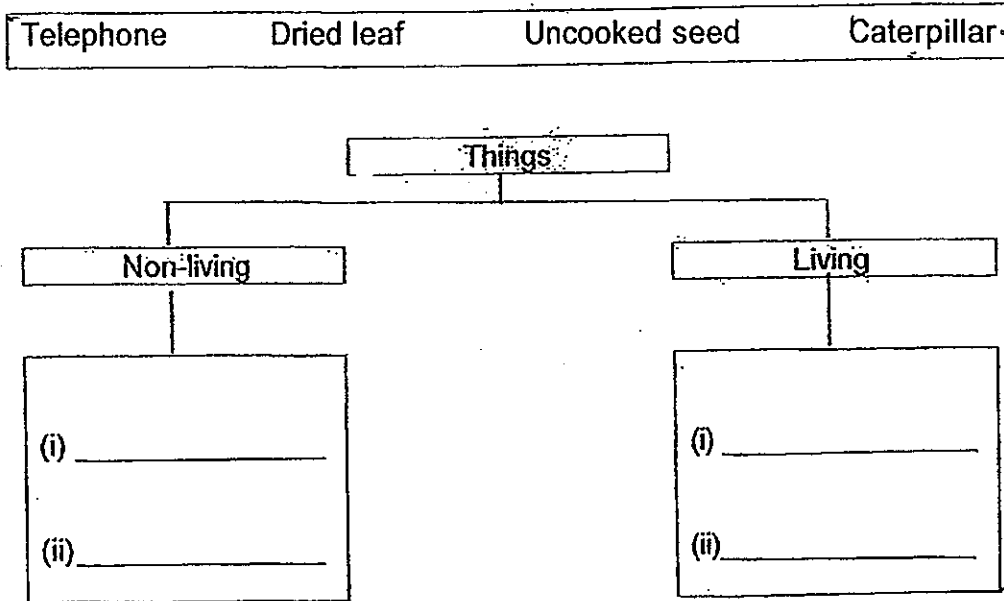

32. For each of the following statements, write "T" for true and "F" for false in the boxes provided. [2]

(a) All insects have wings.	
(b) All birds have feathers on their bodies.	
(c) All birds have wings and can fly.	
(d) Some mammals lay eggs instead of giving birth to their young alive.	

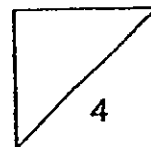

33. Asher bought a pet bird from a pet shop.

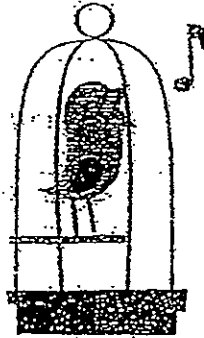

(a) What are the two things that Asher should put into the bird cage so that the bird can stay alive? [1]

---

---

(b) When Asher tried to catch the bird with his hands, the bird tried to fly away. Which two characteristics of living things did the bird show? [2]

(i) \_\_\_\_\_

(ii) \_\_\_\_\_

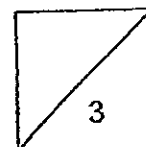

34. The graph below shows the changes in height of a living thing over a period of time.

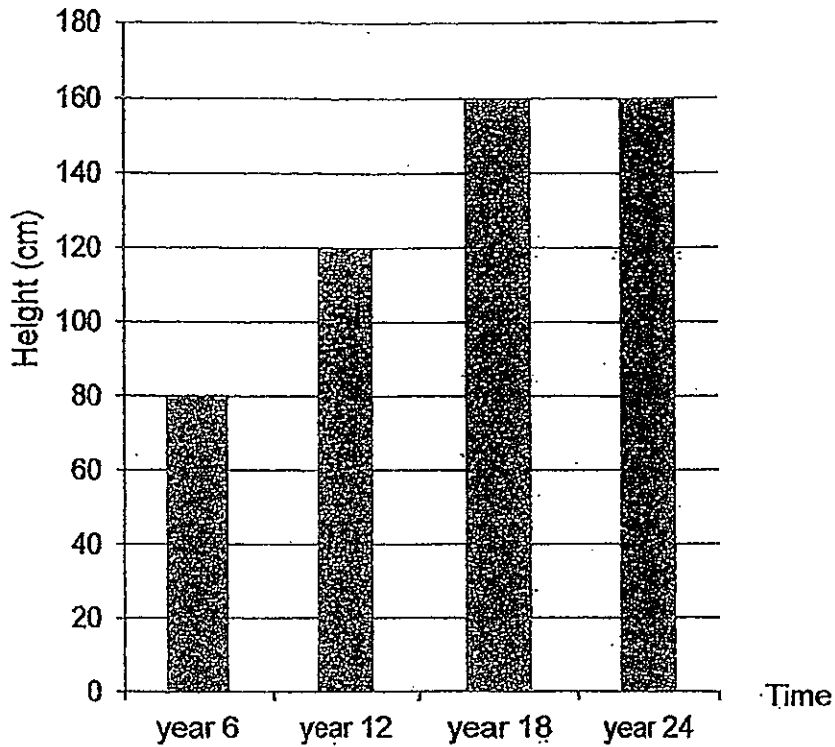

- (a) (i) What is the height of the living thing at year 6? [1]

---

- (ii) How old was the living thing when it was 120cm tall? [1]

---

- (b) What does this graph tell us about living things? [1]

---

---

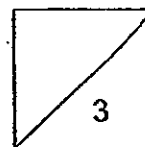

35. (a) Jason wants to find out if an animal is an insect. What are the possible actions he should take to confirm if it is an insect? Put a tick accordingly. [1]

Actions	Tick (✓)
Measure its length	
Check to see if it has wings	
Check to see if it has feelers	
Check to see if it has six legs	
Check to see if it has three body parts	

- (b) Jason found Animal X shown below.



Animal X

He concluded that Animal X is not an insect.  
Do you agree with him? Give a reason to support your answer. [1]

---



---

- (c) How do insects reproduce? [1]

---



---

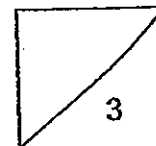

36. Study the two types of plants below carefully.



Hibiscus



Arrowhead

Based on the diagrams above, state one similarity and one difference between the two plants. (Do not compare shape and size.)

[2]

Similarity:

---

---

Difference:

---

---

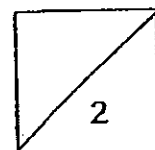

37. The table below shows the characteristics of four plants, A, B, C and D.

Characteristics	Plants			
	A	B	C	D
Has flowers	✓			✓
Grows in the water		✓		✓

(a) Based on the table above, classify the plants (A, B, C and D) in the classification chart below. [2]

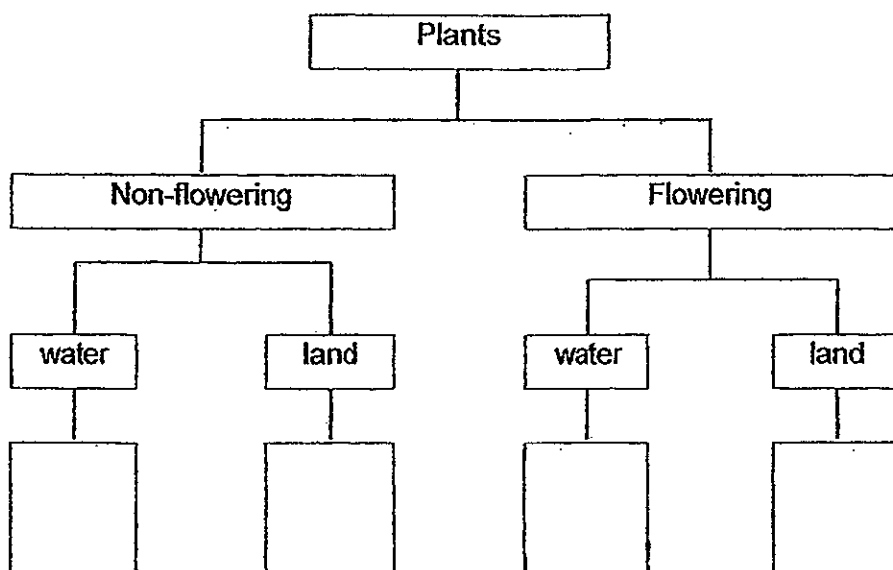

(b) Based on the information given, list two characteristics of Plant B. [2]

(i) \_\_\_\_\_

(ii) \_\_\_\_\_

38. Four animals are shown in the diagram below.

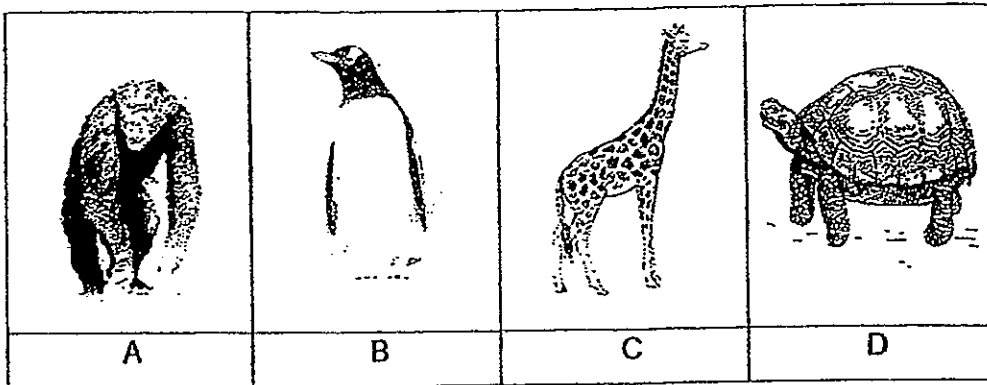

(a) Which two animals, A, B, C or D, can be put into the same group of animals? [1]

\_\_\_\_\_

(b) State two common characteristics between the two animals you have chosen in (a). [2]

(i) \_\_\_\_\_

(ii) \_\_\_\_\_



39. The pictures below show two animals.



Animal X



Animal Y

(a) How are Animal X and Animal Y ~~different~~ in their body covering? [1]

---

---

(b) List 2 functions of the body covering of Animal X. [2]

(i) \_\_\_\_\_

(ii) \_\_\_\_\_

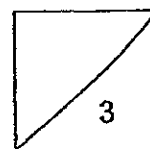

40. (a) Joseph conducted an experiment. He had two similar pieces of bread, A and B. He toasted Bread A and added water to Bread B. Finally, he put both pieces of bread inside a box.

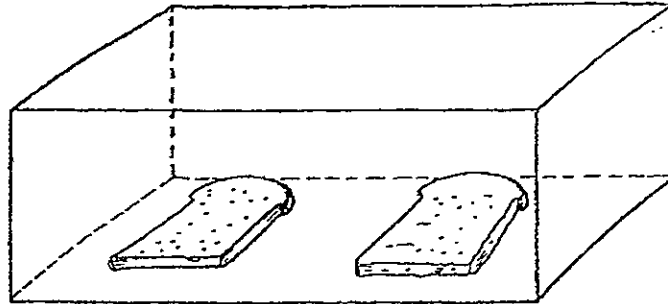

Bread A

Bread B

- (i) What is the aim of Joseph's experiment? [1]

---

---

- (ii) What would he notice about the two pieces of bread after a few days? [1]

---

---

- (b) Why are bacteria also called micro-organisms? [1]

---

---

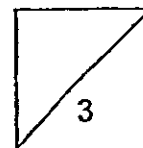

41. Zavier conducted an experiment to find out the amount of fungi growing on different brands of bread after 6 days. The results of the experiment are shown in the table below.

Brand of Bread	Fungal Growth on Bread
A	+++
B	+
C	++
D	++++

Key  
+ amount of fungi

- (a) Based on the results above, which brand of bread will you buy if you want the bread to last the longest? [1]

---

- (b) Explain your answer in (a). [1]

---

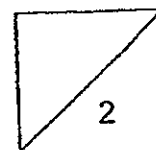

42. Annie's class is involved in a recycling project. The following are the objects Annie found in the recycling bin.

Drinking straw	Mirror	Canned drink	Magazine
Mineral water bottle		Milk carton	

Based on the materials the objects are made of, classify the objects under the correct materials.

[3]

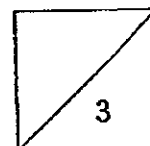
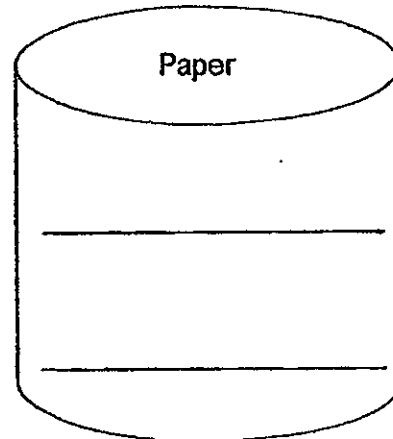
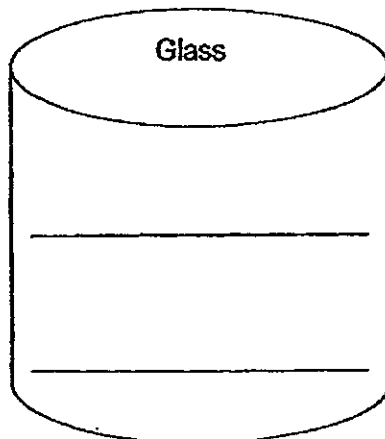
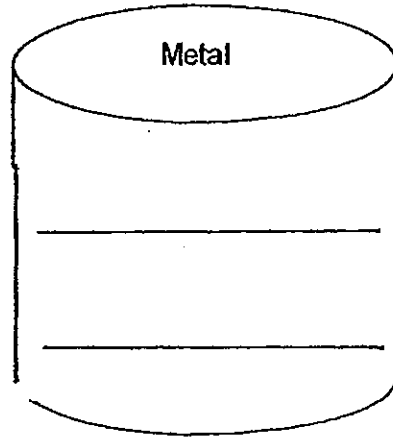
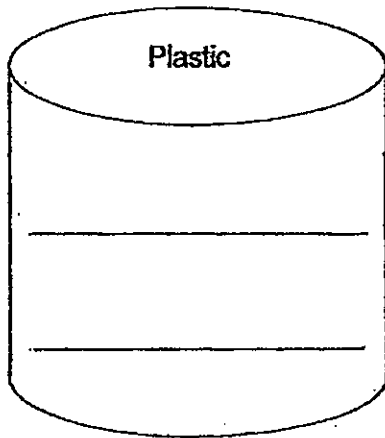

43. Benjamin wanted to buy a file to keep his test papers properly. He saw 2 types of files in the bookshop as shown in the pictures below.

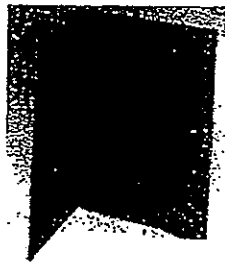

paper file

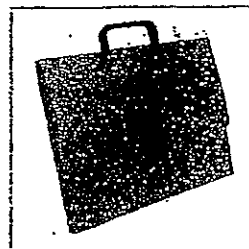

plastic file

- (a) Which file should he buy if he did not want his test papers to get wet? [1]

---

- (b) Give two reasons for your choice in (a). [2]

(i) \_\_\_\_\_

(ii) \_\_\_\_\_

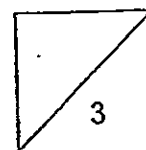

44. (a) Classify the following objects into two groups. [1]

scarf	magnet	blanket in	iron nail
-------	--------	------------	-----------

Group 1	Group 2

(b) Give a suitable heading for each group. [1]

Group 1: \_\_\_\_\_

Group 2: \_\_\_\_\_

(c) State a property of the material that is suitable to make the objects in Group 1 and Group 2. [2]

Group 1: \_\_\_\_\_

Group 2: \_\_\_\_\_

**End of Booklet B**

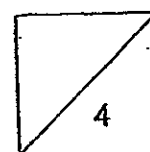

# ANSWER SHEET

**EXAM PAPER 2013**

**SCHOOL : CATHOLIC HIGH SCHOOL**

**SUBJECT : PRIMARY 3 SCIENCE**

**TERM : SA1**

Q1	Q2	Q3	Q4	Q5	Q6	Q7	Q8	Q9	Q10	Q11	Q12	Q13	Q14	Q15	Q16	Q17
4	3	3	2	3	4	4	1	1	1	4	1	2	3	3	2	3

Q18	Q19	Q20	Q21	Q22	Q23	Q24	Q25	Q26	Q27	Q28	Q29	Q30
2	4	4	3	1	3	3	1	2	3	1	4	2

Section B

Q31)

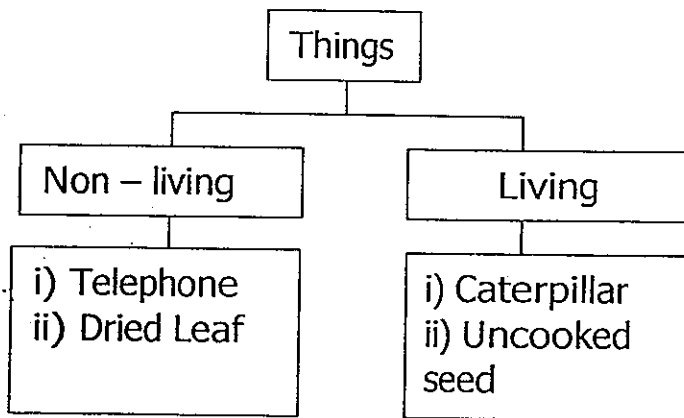

- Q32) a) F  
b) T  
c) F  
d) T

- Q33) a) He should put some water and food  
b) i) Living things respond to changes  
ii) Living things can move by themselves

- Q34) a) i) 80cm  
 ii) 12 years old  
 b) Living things grow

Q35) a)

Actions	Tick (✓)
Measure its length	
Check to see if it has wings	
Check to see if it is has feelers	✓
Check to see if it is has six legs	✓
Check to see if it is has three body parts	✓

- b) Yes. It has 8 legs  
 c) Insects lay eggs

Q36) Similarity: They both have leaves

Difference: The arrowhead is an aquatic plant while the hibiscus is a land plant.

Q37) a)

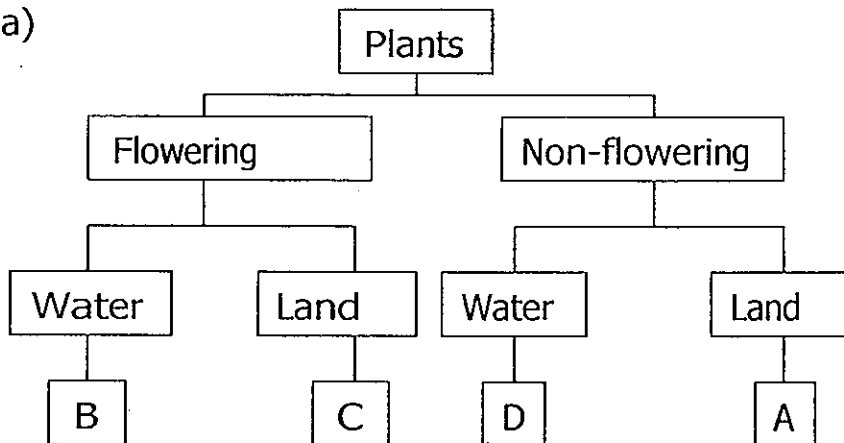

- b) i) Plant B does not have flowers  
 ii) Plant B grows in water

Q38) a) A and C

- b) i) They both have hair  
 ii) They both feed their young with milk

Q39) a) Animal X has feathers while Animal Y has hair

- b) i) The feathers help to keep Animal X warm  
 ii) The feathers help Animal X to fly



Q40) a) i) The aim is to find if mould grows better with or without water  
ii) There will be mould growing on Bread B, and no mould growing on Bread A  
b) They are very small living things that can only be seen using a microscope

Q41) a) Bread B  
b) Bread B has less fungal growth than other brands of bread

Q42) Plastic: Drinking straw, Mineral water bottle  
Metal: Canned Drink  
Glass: Mirror  
Paper: Milk carton, Magazine

Q43) a) Plastic file  
b) i) It is waterproof  
ii) It is strong

Q44) a) Group 1: Scarf, blanket  
Group 2: Magnet, Iron nail  
b) Group 1: Made of Fabric  
Group 2: Made of Metal  
c) Group 1: Soft  
Group 2: Hard

